

(mm)

Model  
**RSR**  
Regulator (relieving type)

Model  
**RNR** (Semi-standard)  
Regulator (non-relieving type)

- Either reduces or maintains pressure to activate pneumatic components in a stable condition.

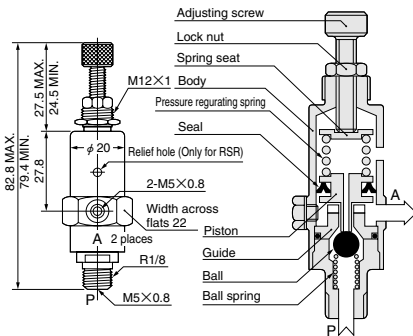

Symbols	
Relieving type	Non-relieving type
<b>RSR</b>	<b>RNR</b>

### Specifications

Item	Model	RSR	RNR (semi-standard)
Operation type		Relieving type	Non-relieving type
Port size		P: R1/8 (male thread) or M5×0.8 (female thread) A: M5×0.8 (2 places)	
Maximum operating pressure MPa(kg/cm <sup>2</sup> ) [psi.]		0.93 (9.5) [135]	
Operating pressure range <sup>min</sup> MPa(kg/cm <sup>2</sup> ) [psi.]		0.2~0.7 {2.0~7.1} [29~102]	
Mounting direction		Any	
Material	Body	Brass (nickel plated)	
	Seal	Synthetic rubber	
Mass	g [oz.]	108 [3.81]	
Standard equipment	Lock nut(110-21A)	1 pc. each	
	Lock washer(100-35)		

Note: For low-pressure application, consult us.

### Flow rate

