

# LUBRICATORS

## L150, L300, L600

- Constant lubrication even with varied flow rates or pressure.
- Scaled dial ensures easy droplet regulation.
- Easy to attach and remove click-on bowl.
- Micro lubricator also included in model series. Assures steady lubrication even in long piping.
- Drain cock, and drain cock with fitting, are optional.



### Specifications

Item	Model	Standard	L150	L300	L600
	Micro lubricator		—	L301	L601
Media		Air			
Port size	Rc		1/8, 1/4	1/4, 3/8	1/4, 3/8, 1/2
Maximum operating pressure	MPa [psi.]	0.93 [135]			
Proof pressure	MPa [psi.]	1.47 [213]			
Operating temperature range (atmosphere and media) °C [°F]		5~60 [41~140]			
Oil capacity	cc [in. <sup>3</sup> ]		25 [1.5]	85 [5.2]	160 [9.8]
Recommended lubrication		Turbine oil Class 1 [ISO VG32] or equivalent			
Mass	kg [lb.]		0.17 [0.37] (0.18 [0.40]) <sup>Note</sup>	0.36 [0.79]	0.42 [0.93]
Materials	Body		Aluminum die-casting	Zinc die-casting	Aluminum die-casting
	Bowl		Polycarbonate		
Standard attachments			—	Bowl guard	

Note: Figure in parentheses ( ) shows mass with bowl guard.

### Symbol

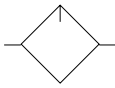

### Order Codes

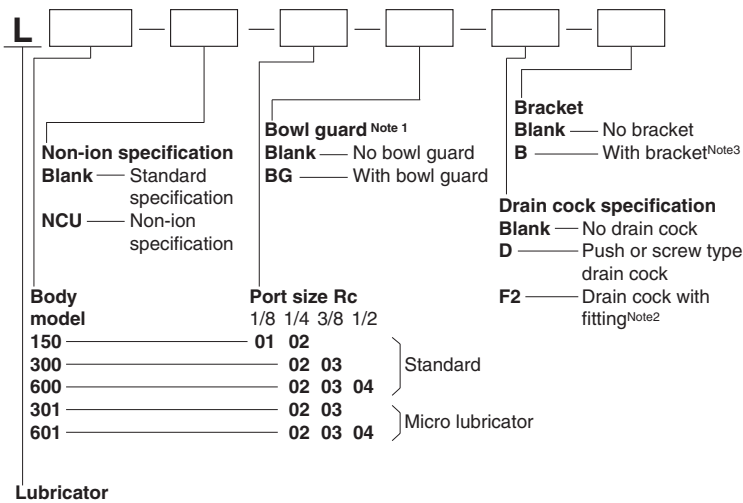

Notes: 1. For L150 only. Standard specification for all models other than L150.  
2. Available for L150 as "With bowl guard: -BG" only.  
3. For the bracket order codes and dimensions, see p.95~96.

### Inner Construction

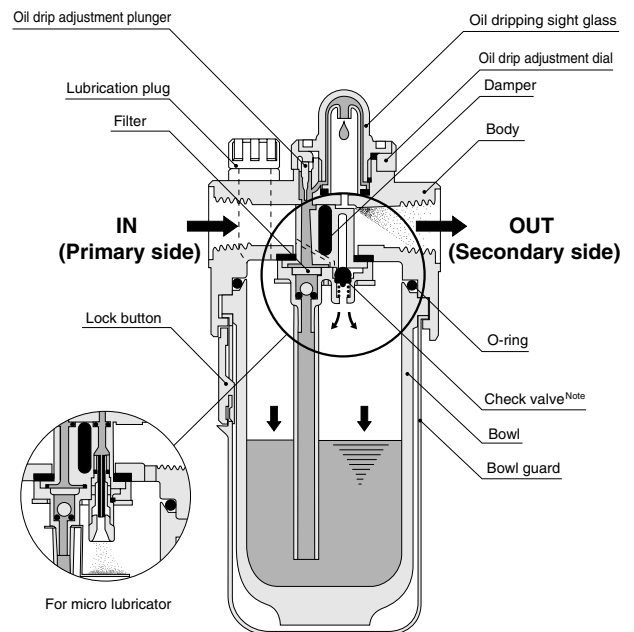

### Micro Lubricator for System Upgrade

Note: Not available for L150.

The micro lubricator uses a pipe and nozzle to generate an oil mist inside the bowl, and supplies only the most finely microscopic mist to the OUT side.

The micro mist rides easily on the air flow, to ensure faster, more assured lubrication supply. This method is effective even when the piping distance to the actuator is unusually far or is subject to complex twists and turns, or when the actuator is mounted in a high position.

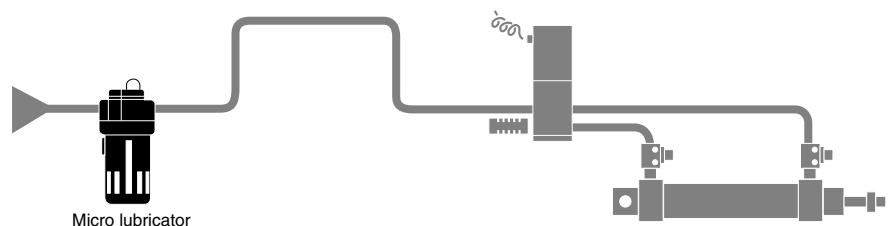

# Flow Rate Characteristics

## L150

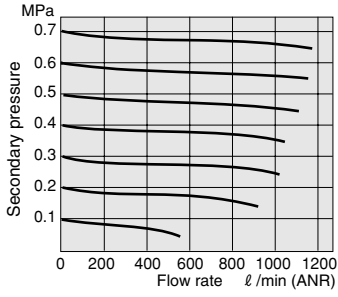

## L300

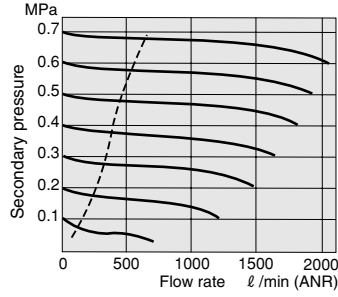

## L600

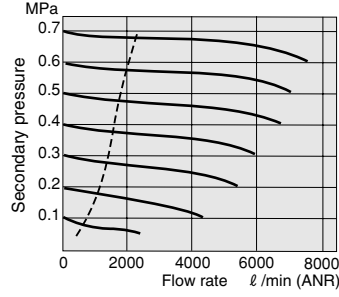

1MPa = 145psi.  
1 l/min = 0.0353ft.<sup>3</sup>/min.

Note: The dotted line shows the smallest flow rate of micro lubricator allowed. A micro mist cannot be formed below this flow rate. Always select a product with a flow rate that exceeds this dotted line.

# Minimum Flow Rate for Dripping Oil

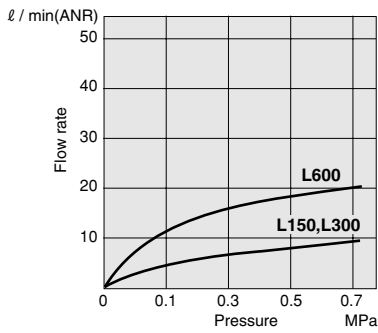

1MPa = 145psi. 1 l/min = 0.0353ft.<sup>3</sup>/min.

# Dimensions of Lubricators (mm)

## L150

CAD L150

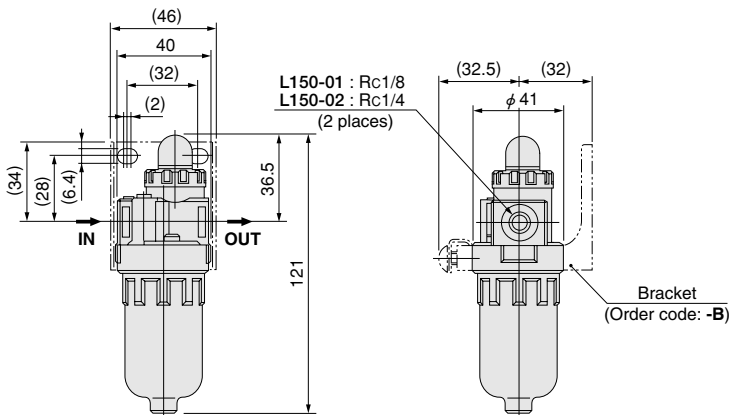

### Optional drain cocks

● Push type :-D

● Push type with fitting :-BG-F2

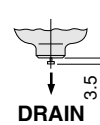

DRAIN

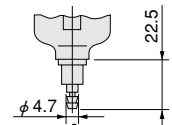

DRAIN

**L300  
L301**

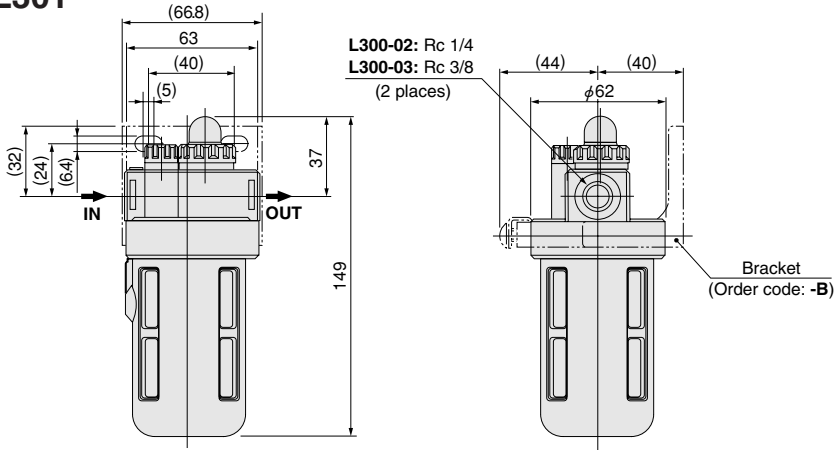

**Optional drain cocks**

- Screw type: -D
- Screw type with fitting: -F2

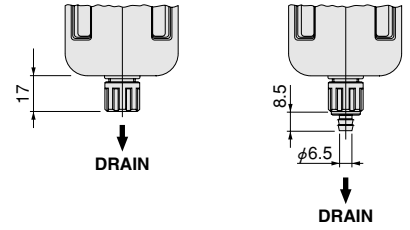

**L600  
L601**

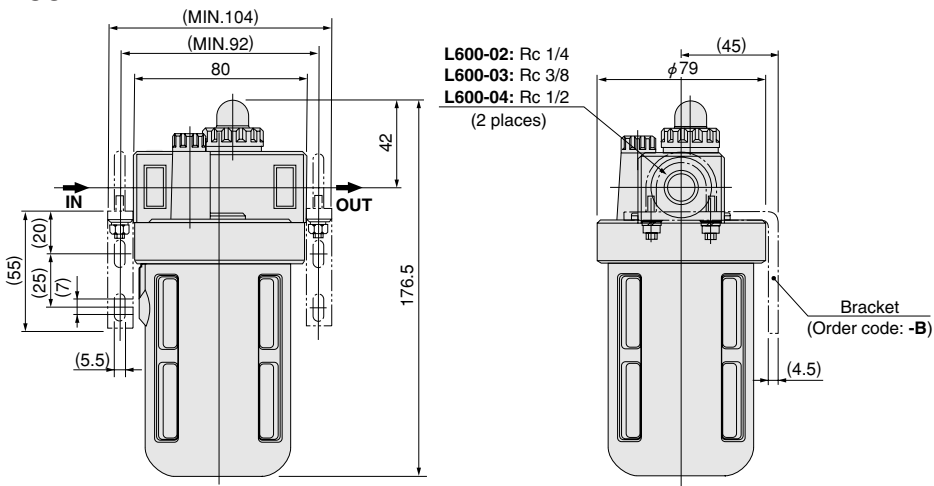

**Optional drain cocks**

- Screw type: -D
- Screw type with fitting: -F2

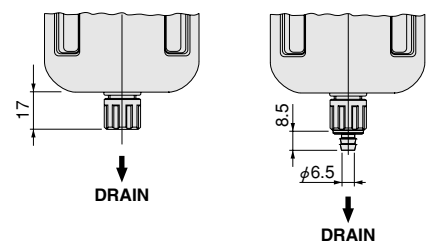

# MODULES AND ADAPTERS



- F module is a connector facilitating combinations of Multi Series equipment of the same body size.
- D module offers a mounting bracket function.
- T module provides branch piping at desired locations.
- S adapter allows easy installation and removal of equipment without disturbing the piping.
- Standard can be used as NCU specification.

## Model List

### For 150, 300 and 600 series

Module, adapter Body size	F module (For modules only)	D module (Brackets for combined use)	T module (Branch piping)		S adapter (Port connection)	
	<b>F</b> Multi Series 8-15F	<b>D</b> Multi Series 8-15D	<b>T</b> Connection port 8-15T	<b>DT</b> Connection port 8-15DT	<b>S</b> Connection port 8-15S	<b>DS</b> Connection port 8-15DS
15 (For 150 series)						
30 (For 300 series)						
60 (For 600 series)						

### For connections between different sizes

Module Body size	D module (Brackets for combined use)
20 (For connecting 150 and 300 series)	For 300 series 8-20D For 150 series
40 (For connecting 300 and 600 series)	For 600 series 8-40D For 300 series

Remark: Material is zinc die-casting.

## Order Codes



- Module and adapter**
- F — F module
  - D — D module for bracket-combined use
  - T — T module
  - DT — T module for bracket-combined use
  - S — S adapter
  - DS — S adapter for bracket-combined use

### Body size

- 15 — For 150 series, HR200 and HRA200
- 20 — For connecting 150 and 300 series<sup>Note 1</sup>
- 30 — For 300 series
- 40 — For connecting 300 and 600 series<sup>Note 1</sup>
- 60 — For 600 series, HR600 and HRA600

Port size <sup>Note 2</sup>	Rc		Applicable body size
	1/8	1/4	
1	2	1/2	150
2	3		300
2 <sup>Note 3</sup>	3	4	600

- Notes: 1. Used only with D module.  
2. Not available in F module or D module.  
3. Used only with S adapter and DS adapter.

For details about equipment combinations, see p.58.

## Dimensions of F Modules (mm)

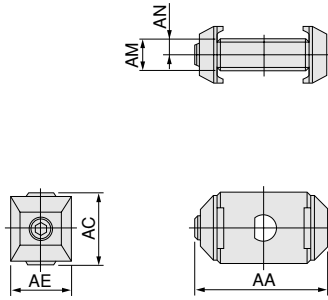
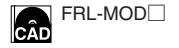

Type Code	AA	AC	AE	AM	AN	Mass g
8-15F	36	20	17.4	8	4	38
8-30F	42	24	19.4	10	5	63
8-60F	56.5	30	31	12	6	150

Note: When assembling with other equipment, add the AM dimensions to the total.

## Dimensions of D Modules (mm)

8-15D  
8-30D

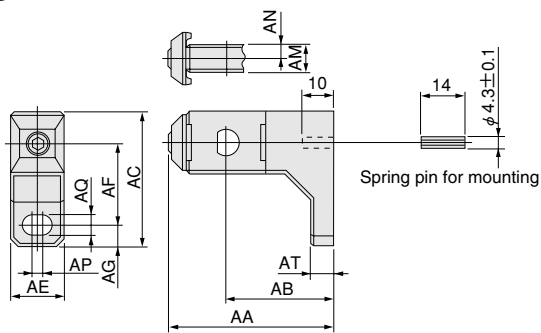
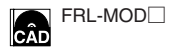

Model Code	AA	AB	AC	AE	AF	AG	AM	AN	AP
8-15D	50.5	32	49	17.4	31	8	8	4	4
8-30D	61.5	40	50.5	19.4	31	8	10	5	4

Model Code	AQ	AT	Mass g
8-15D	7	6	84
8-30D	7	8	137

Note: When assembling with other equipment, add the AM dimensions to the total.

8-20D  
8-40D

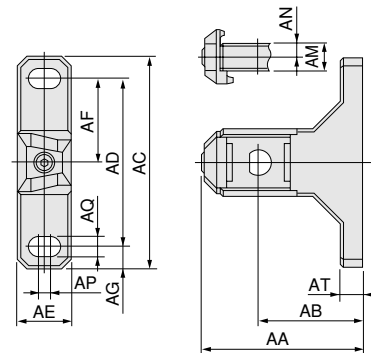

Model Code	AA	AB	AC	AD	AE	AF	AG	AM	AN	AP
8-20D	61.5	40	78	62	19.4	31	8	10	5	4
8-40D	74	45	90	70	31	35	10	16.8	6	4

Model Code	AQ	AT	Mass g
8-20D	7	8	141
8-40D	9	8	300

Note: When assembling with other equipment, add the AM dimensions to the total.

8-60D

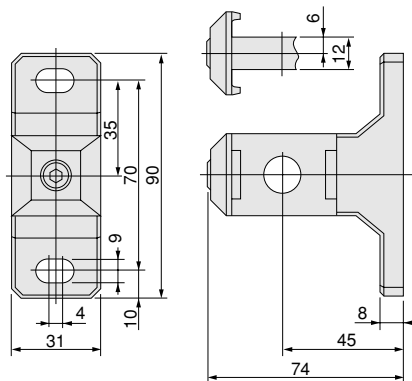

Mass: 260 g

Note: When assembling with other equipment, add 12mm to the total.

# Dimensions of T Modules (mm)

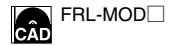

- 8-15T
- 8-30T
- 8-60T

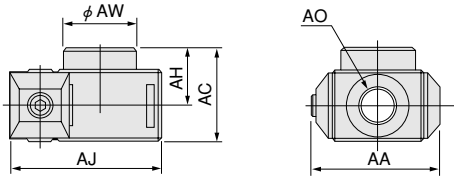
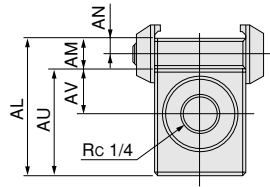

Model Code	AA	AC	AH	AJ	AL	AM	AN	AO	AU	AV	AW	Mass g
8-15T1	36	27	17	43.5	39	8	4	Rc1/8	31	13	20	116
8-15T2	36	27	17	43.5	39	8	4	Rc1/4	31	13	20	110
8-30T2	42	31	19	49.5	45	10	5	Rc1/4	35	15	24	196
8-30T3	42	31	19	49.5	45	10	5	Rc3/8	35	15	24	181
8-60T3	56.5	40	24	66.5	57	12	6	Rc3/8	45	19	32	271
8-60T4	56.5	40	24	66.5	57	12	6	Rc1/2	45	19	32	264

Note: When assembling with other equipment, add the AL dimensions to the total.

- 8-15DT
- 8-30DT

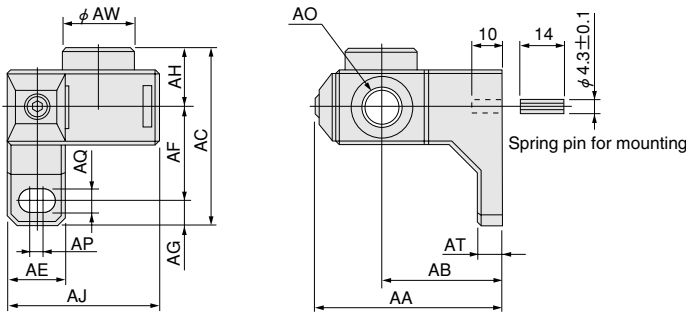
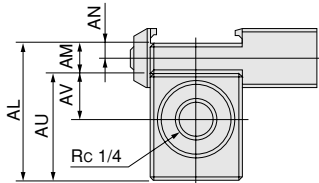

Model Code	AA	AB	AC	AE	AF	AG	AH	AJ	AL
8-15DT1	50.5	32	56	17.4	31	8	17	44	39
8-15DT2	50.5	32	56	17.4	31	8	17	44	39
8-30DT2	61.5	40	58	19.4	31	8	19	50	45
8-30DT3	61.5	40	58	19.4	31	8	19	50	45

Model Code	AM	AN	AO	AP	AQ	AT	AU	AV	AW
8-15DT1	8	4	Rc1/8	4	7	6	31	13	20
8-15DT2	8	4	Rc1/4	4	7	6	31	13	20
8-30DT2	10	5	Rc1/4	4	7	8	35	15	24
8-30DT3	10	5	Rc3/8	4	7	8	35	15	24

Model Code	Mass g
8-15DT1	161
8-15DT2	155
8-30DT2	273
8-30DT3	257

Note: When assembling with other equipment, add the AL dimensions to the total.

- 8-60DT

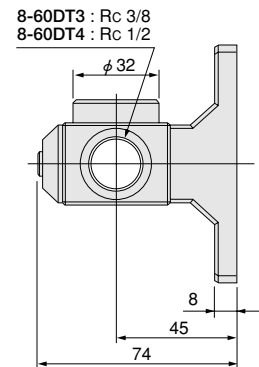
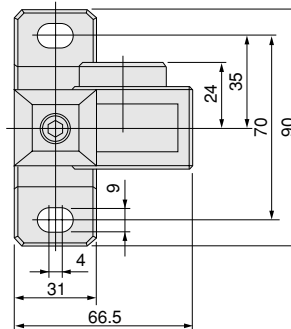
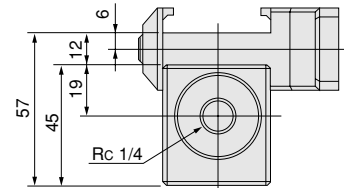

Mass  
 8-60DT3: 385g  
 8-60DT4: 375g

Note: When assembling with other equipment, add 57mm to the total.

# Dimensions of S Adapters (mm)

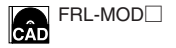

- 8-15S
- 8-30S
- 8-60S

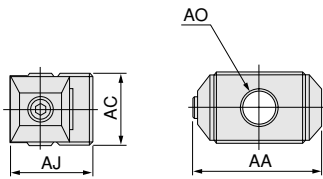
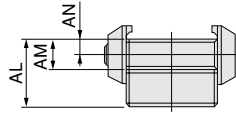

Model	Code	AA	AC	AJ	AL	AM	AN	AO	Mass g
8-15S1		36	20	24.5	20	8	4	Rc1/8	51
8-15S2		36	20	24.5	20	8	4	Rc1/4	49
8-30S2		42	24	26.5	22	10	5	Rc1/4	81
8-30S3		42	24	26.5	22	10	5	Rc3/8	78
8-60S2		56.5	32	37.5	28	12	6	Rc1/4	190
8-60S3		56.5	32	37.5	28	12	6	Rc3/8	187
8-60S4		56.5	32	37.5	28	12	6	Rc1/2	183

Note: When assembling with other equipment, add the AL dimensions to the total.

- 8-15DS
- 8-30DS

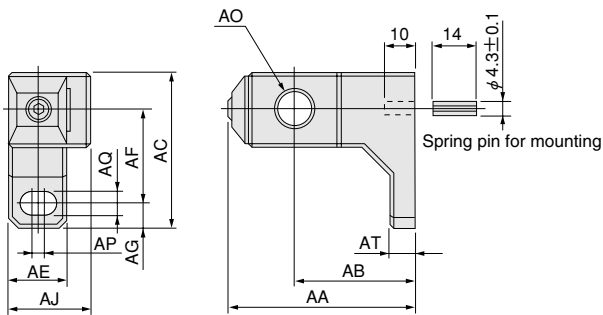
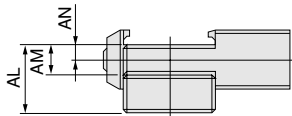

Model	Code	AA	AB	AC	AE	AF	AG	AJ	AL	AM	AN	AO	AP	AQ	AT
8-15DS1		50.5	32	49	18	31	8	25	20	8	4	Rc1/8	4	7	6
8-15DS2		50.5	32	49	18	31	8	25	20	8	4	Rc1/4	4	7	6
8-30DS2		61.5	40	51	20	31	8	27	22	10	5	Rc1/4	4	7	8
8-30DS3		61.5	40	51	20	31	8	27	22	10	5	Rc3/8	4	7	8

Model	Code	Mass g
8-15DS1		96
8-15DS2		94
8-30DS2		155
8-30DS3		150

Note: When assembling with other equipment, add the AL dimensions to the total.

- 8-60DS

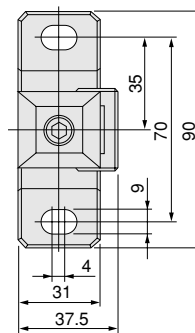
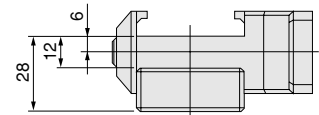

8-60DS2 : Rc 1/4  
 8-60DS3 : Rc 3/8  
 8-60DS4 : Rc 1/2

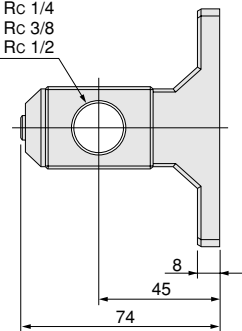

Mass  
 8-60DS2: 302g  
 8-60DS3: 299g  
 8-60DS4: 295g

Note: When assembling with other equipment, add 28mm to the total.

# BRACKETS



## Bracket Models and Applicable Components

Components type		Bracket model	Remark
F.R.L. combinations	C150	<b>8-15D</b>	D module for bracket-combined use, standard equipment
	C200	<b>8-20D</b>	
	C300	<b>8-30D</b>	
	C400	<b>8-40D</b>	
	C600	<b>8-60D</b>	
Filter regulators	FR150	<b>8-15 (8-15A)</b>	Standard equipment
	FR300	<b>8-30 (8-30A, 8-60B)</b> <sup>Note2</sup>	
	FR600	<b>8-65 (8-60B)</b> <sup>Note2</sup>	
Air filters	F150	<b>8-15A</b>	Body supporting type, optional
	F300	<b>8-30A (8-60B)</b> <sup>Note2</sup>	Piping supporting type, optional
	F600	<b>8-60B</b>	Piping supporting type, optional
Mist filters	MF300	<b>8-30A (8-60B)</b> <sup>Note2</sup>	Body supporting type, optional
	MF400	<b>8-60B</b> <sup>Note2</sup>	Piping supporting type, optional
	MF600		
Micro mist filters	MMF150	<b>8-30A (8-60B)</b> <sup>Note2</sup>	Body supporting type, optional
	MMF300	<b>8-60B</b> <sup>Note2</sup>	Piping supporting type, optional
	MMF400		
Regulators	R150	<b>8-15</b>	Standard equipment
	R300	<b>8-30 (8-60B)</b> <sup>Note2</sup>	
	R600	<b>8-65 (8-60B)</b> <sup>Note2</sup>	
Precision regulator	PR200	<b>8-21Z</b>	Body supporting type, optional
High-relief regulators	HR200	<b>8-22Z</b>	Body supporting type, optional
	HR600		
	HRA200		
	HRA600		
Manifold regulators	MR300	<b>8-30D</b>	D module for bracket-combined use, optional
Lubricators	L150	<b>8-15A</b>	Body supporting type, optional
	L300	<b>8-30A (8-60B)</b> <sup>Note2</sup>	Piping supporting type, optional
	L600	<b>8-60B</b> <sup>Note2</sup>	
Residual pressure exhaust valves	300V	<b>8-31C</b>	Body supporting type, optional
	600V		

Notes: 1. Models in parentheses ( ) are non-standard, but are acceptable for use.  
 2. Pipe supporting type brackets (8-60B) are sold in a set of two brackets.



# Dimensions of Brackets (mm)



## For Filter Regulator and Regulator

### 8-15

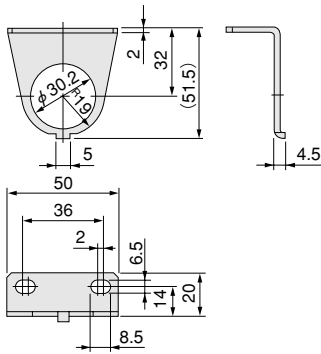

Mass: 31g

### 8-30

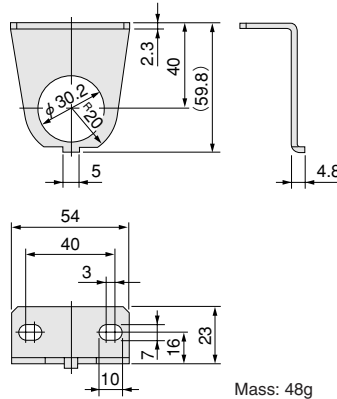

Mass: 48g

### 8-65

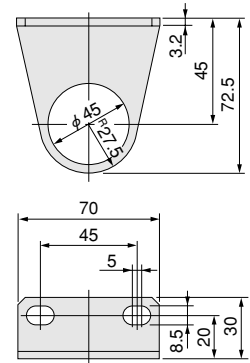

Mass: 69g

## For Air Filter, Mist Filter, Micro Mist Filter, and Lubricator

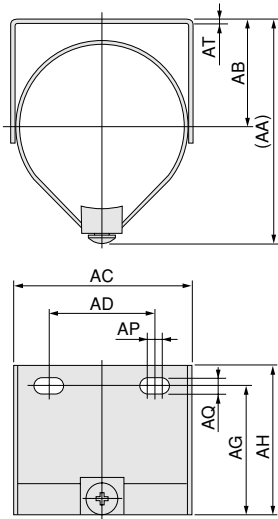

Mass  
8-15A: 60g  
8-30A: 80g

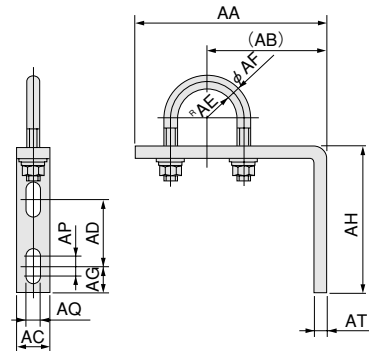

Mass: 107g

Model	Code	AA	AB	AC	AD	AG	AH	AP	AQ	AT
8-15A		64	32	46	32	50	56	2	6.4	1.2
8-30A		84	40	66.8	40	48	56	5	6.4	1.2

Model	Code	AA	AB	AC	AD	AE	AF	AG	AH	AP	AQ	AT
8-60B		72	45	12	25	11	5	10	55	7	5.5	4.5

Note: Pipe supporting type brackets (8-60B) are sold in a set of two brackets.

## For Precision Regulator

### 8-21Z

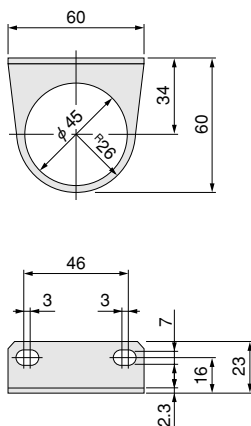

Mass: 42g

## For High-relief Regulator

### 8-22Z

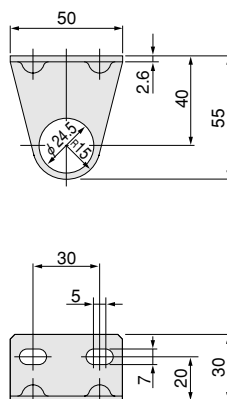

Mass: 52g

## For Residual Pressure Exhaust Valve

### 8-31C

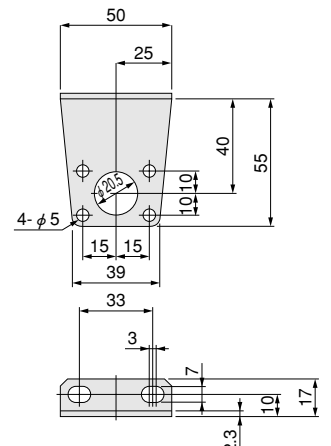

Mass: 50g

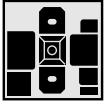

## Module

### Installation

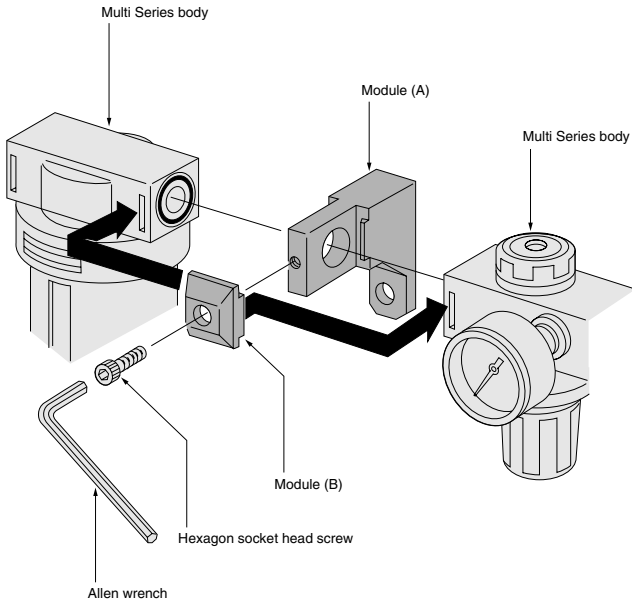

1. On all Multi Series equipment, the side displaying an arrow mark on the top of the body indicates the IN port (primary side).
2. Align convex section of modules (A) and (B) in the grooves of the Multi Series body, and use a hexagon socket head screw to tighten and secure them in place.

- Cautions:**
1. For the module types applicable to each Multi Series type, see p.91.
  2. The Multi Series modules should not be allowed to sag when mounted. As there is a possibility that they will sag under the weight of connections of steel piping or other heavy piping, always connect module brackets to both ends of the modules before mounting.
  3. There is only one mounting hole when mounting a module using one of either 8-15D or 8-30D onto a mechanical device, causing an unstable installation. Use the spring pin supplied to prevent the unit from rotating. The pin hole here is  $\phi 4.6$  with a depth of 6.
  4. Assemble the T module so that the piping port faces upward.

### [Mounting example]

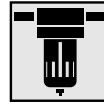
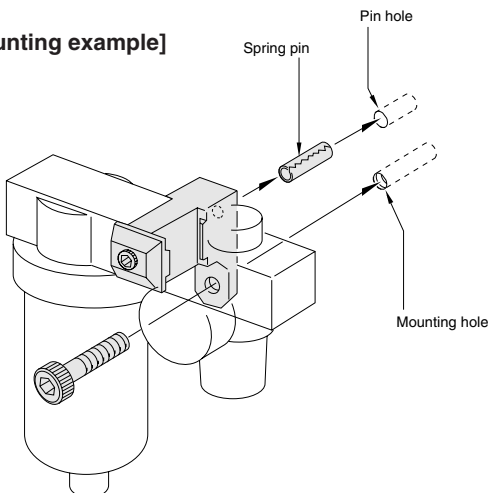

## Filter Regulator, Filter, and Lubricator

### Mounting and piping

Mount in a vertical position, with the piping connections on the top and the drain port on the bottom.

### Bowl

Because the bowl is made of polycarbonate, avoid subjecting it to excessive force or shocks. Also, do not use it in atmospheres subject to organic solvents, etc.

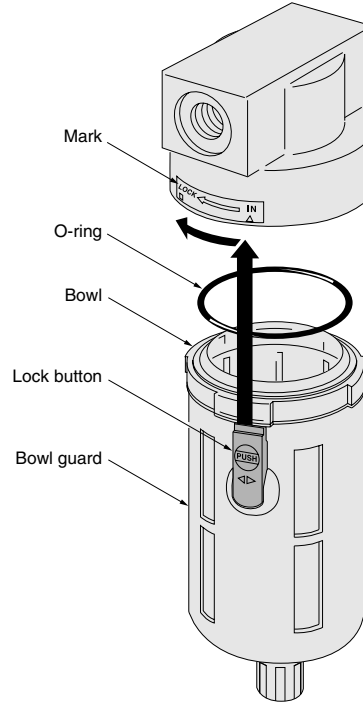

### ● Removing the bowl

While pushing down on the red lock button, rotate the bowl and bowl guard to the right (the direction opposite to the arrow mark) until it is aligned to the IN mark, then remove the bowl and bowl guard from the body.

### ● Mounting the bowl

1. Align the bowl and bowl guard to the convex section along their rims, and set the bowl into the bowl guard.
2. Align the lock button to the IN mark, and insert into the body. While pressing the bowl against the body, rotate it to the left (the direction shown by the arrow mark) until it reaches the LOCK position, and secure in place.

- Cautions:**
1. Always shut off the media before removing or mounting the bowl.
  2. Set the O-ring onto the body, and then mount the bowl and bowl guard.
  3. The bowl for the 150 series is a screw-in type. For removal or mounting, manually rotate the bowl or bowl guard.
  4. Use a neutral detergent to clean the bowl.

### Filter

1. Drain the collected liquid from the air filter on a periodic basis.
2. To clean the air filter element, remove the element and blow it off with compressed air, etc.

**Drain cock**● **Push type****150 series**

(Air filter Standard  
Lubricator Order code: **-D**)

Pressing the button opens the drain port, and the collected liquid is expelled.

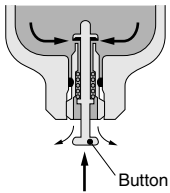
● **Push type with fitting****150 series**

(Air filter Order code: **-BG-F1**  
Lubricator Order code: **-BG-F2**)

Pushing the fitting upward opens the drain port, and the collected liquid is expelled.

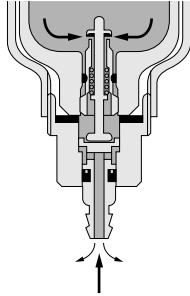
● **Screw type****300-600 series**

(Air filter Standard  
Lubricator Order code: **-D**)

Rotating the drain knob to the left opens the drain port, and the collected liquid is expelled.

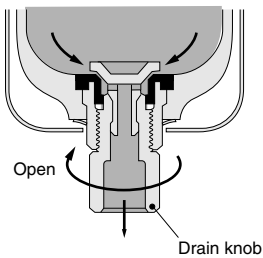
● **Screw type with fitting****300-600 series**

(Air filter Order code: **-F1**  
Lubricator Order code: **-F2**)

Rotating the drain knob to the left opens the drain port, and the collected liquid is expelled.

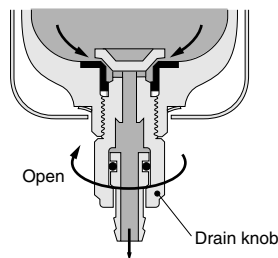

**Caution:** The drain knob should be operated using the fingertips.

● **Auto drain type****300-600 series**

(Air filter Order code: **-A**)

When a certain volume of collected liquid has accumulated, or when the pressure inside the bowl has fallen to less than 0.02MPa [3psi.], the collected liquid is automatically expelled. The collected liquid may also be expelled manually by turning the drain knob to the left.

**Cautions:** 1. In the auto drain, air is exhausted from the drain port until the supply pressure reaches 0.15MPa [22psi.]. This is normal, and even rotating the drain knob in this situation will not prevent the air from bleeding out.

(If the time required for the supply pressure to rise to 0.15MPa [22psi.] seems too long, consult us.)

- The drain knob should be operated using the fingertips.
- If attaching a tube to the fitting, use a nylon tube with inner diameter of 6mm. Do not let the tube bend in the area near the fitting connection.
- The fitting can be rotated freely in any direction. As a result, the tube does not need to be removed even when manually draining the collected liquid.

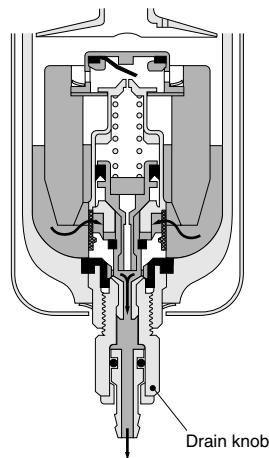
**Lubrication**

- Use Turbine Oil Class 1 (ISO VG32) or an equivalent for lubrication. Avoid using spindle oil or machine oil.
- For lubrication, use an Allen wrench to remove the plug from the lubrication port, and supply oil until the bowl is 80% filled.

**Caution:** Even though lubrication can be carried while supplying compressed air for the L300 and L600, lubrication cannot be carried while supplying compressed air for the L150.

**Oil drip-rate adjustment**

Rotating the lubricator dial to the left increases the oil drip-rate. Use the adjustment marks on the body and the numbers on the dial to adjust the oil drip-rate.

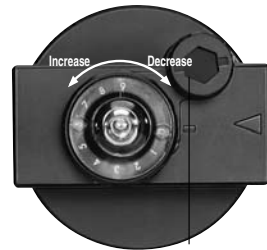

Adjusting mark

- Cautions:** 1. While the dial can be rotated continuously to the right, the rate of change for the oil dripping volume does not correspond to the numbers on the dial.
2. The numbers on the dial represent rough oil drip-rate, not the number of droplets.

# Handling Instructions and Precautions



## Filter Regulator, Regulator, Precision Regulator, Manifold Regulator, and High-relief Regulator

### Mounting and piping

#### ● General overview for regulators

In regulator configurations (with the exception of types with built-in check mechanism), the OUT port (secondary) pressure may not be exhausted to the IN port (primary) side even when the IN port pressure is 0MPa. To ensure that exhaust is performed, either use a type with built-in check mechanism, or install a check valve alongside. If a regulator with built-in check mechanism installed after the solenoid valve for cylinder pressure adjustment performed, make sure that cylinder back pressure does not cause secondary pressure on the regulator with built-in check mechanism to rise above the set pressure. The check mechanism may not operate correctly. (As a guide, use at a pressure differential between the push and pull sides of 0.3MPa or less.)

Also, because regulator (with the exception of the High-relief Regulator) relief ports are smaller than the diameter of the piping port, they may not be able to respond to sudden increases in pressure on the OUT port (secondary) side. For situations where pressures can rise sharply due to a force being applied to the cylinder externally, either use a High-relief Regulator or set the relief valve to OUT.

#### ● Precision Regulator

1. If mounting the Precision Regulator as a single unit, use a bracket (optional). A ring nut for panel mounting can also be used.
2. When piping to the Precision Regulator, position the piping so that the air supply side connects to the IN port and the actuator side connects to the OUT port. To prevent the fitting on the OUT port side from interfering with the damper tube, use piping with inner diameter at least 3mm [0.12in.] or more.



- Cautions:**
1. The regulator cannot be used with the IN port and the OUT port in the opposite positions.
  2. When mounting a fitting on the OUT port, be careful to avoid damaging the damper tube. In addition, avoid using a plug or a fitting with too small inner diameter in the OUT port. Bending the damper tube or blocking the hole could damage the precision regulator function, preventing accurate regulating pressure.
  3. Avoid a mounting position that blocks the relief hole. Blocking the relief hole could prevent regulating pressure.

#### ● Manifold Regulator

1. Use sufficiently large IN port piping, and supply via the IN ports at both manifold ends as much as possible. Moreover, when using five or more units on a manifold, mount a T module somewhere in the middle of the units, and supply via the IN ports in at least three different locations.
2. To stabilize secondary pressure, ensure a sufficiently large pressure differential (0.3MPa [44psi.] MIN.) between the IN port pressure and OUT port pressure.

#### ● High-relief Regulator

1. The High-relief Regulator's IN port (primary side) is on the top surface of the body, where the arrow ► mark is located.
2. The High-relief Regulator can be mounted as a module with any equipment in the air preparation Multi Series. Module formation and equipment compatibility for HR200 and HRA200 is the same as the 150 series, and for HR600 and HRA600, the same as the 600 series.
3. For single unit mounting, use brackets (order code :-B). A ring nut for panel mounting can also be used.
4. When mounting a pressure gauge, never grab the pressure gauge body for tightening. Always use a wrench on the square section around the connection port to tighten.
5. When mounting a muffler or exhaust filter on the EXH port, use the following table to select the type.

Model	Recommended muffler, exhaust filter
HR200 HRA200	KM-22, KM-23 EF300, EF600, EF800
HR600 HRA600	KM-31 EF300, EF600, EF800

For details, see p.549 and 552.

6. While any mounting direction is acceptable, mounting with the EXH port pointing straight up could result in noisy operation. In this case, change the pressure setting, increase the exhaust volume, or perform some other preventive measures.
7. If using a mounting ring to mount the regulator, use a mounting torque of 980.7N·cm [86.7in·lbf] or less.

- Cautions:**
1. Avoid operating methods that involve setting a valve on the primary side of the High-relief Regulator and repeatedly switching the primary pressure.
  2. If mounting a muffler, etc., on the EXH port, use a tightening torque for HR200 and HRA200 of 294.2N·cm [26.0in·lbf] or less, and for HR600 and HRA600, 490.3N·cm [43.4in·lbf] or less. When mounting, always use a wrench on the hexagonal section of the exhaust plug. Avoid using steel piping to connect the EXH port.
  3. In the external pilot type, exhausting primary pressure while supplying pilot air could cause damage to the diaphragm. For this reason, exhaust the primary side of the regulator that controls pilot pressure, and the primary side of the external pilot type at the same time.

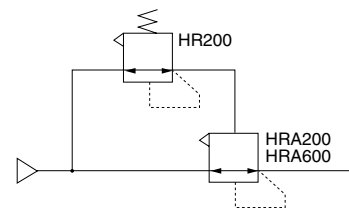

4. To avoid interfering with the piping volume, select a regulator with a large relief flow rate for the pilot regulator to be used for the external pilot type. In addition, do not allow the pilot air piping length to exceed the values shown in the table below.

O.D × I. D.mm [in.]	Piping length m [ft.]
4×2 [0.157×0.079]	2 [6.6]
6×4 [0.236×0.157]	20 [65.6]
8×6 [0.315×0.236]	50 [164]

### Pressure regulation

**Caution:** Perform the setting while checking the primary pressure and secondary pressure gauge displays. Rotating the knob too far could cause damage to the internal parts. Be particularly careful not to rotate it too far during depressurization, since time is required for relief.

#### ● Filter Regulator, Regulator, Manifold Regulator

Perform pressure regulation by pulling out the knob firmly. Rotating it to the right (clockwise direction) increases the pressure, and rotating to the left (counterclockwise direction) reduces the pressure. After regulating pressure, push the knob back into the body and lock it in place.

- Cautions:**
1. Do not attempt to rotate the knob while in the locked position.
  2. In the FR150 and R150 series, vibration noise can occur when the pressure differential between the primary pressure and setting pressure is large (0.7MPa [102psi.] or more). In this situation, reduce the pressure differential (0.5MPa [73psi.] or less).

#### ● Precision Regulator, High-relief Regulator

Perform regulating pressure by pulling out the knob firmly. Rotating it to the right (clockwise direction) increases the pressure, and rotating to the left (counterclockwise direction) reduces the pressure. After regulating pressure, push the knob back into the body and lock it in place.



**Remark:** When regulating pressure, connect a pressure gauge of a class JIS 1.5 or equivalent to the Precision Regulator's pressure gauge connection port (Rc1/4).

- Cautions:**
1. To maintain accurate pressure adjustment conditions while locked, the Precision Regulator knob includes a free (neutral) state between the lock state and pressure adjustment state. To switch between the regulating pressure and lock states, pull the knob firmly out or push it in until a clicking sound shows that it has firmly arrived in the lock state or pressure adjustment state.
  2. The Precision Regulator is a bleed type, which means that a slight amount of air constantly bleeds out of the bleed hole while the secondary side is undergoing pressure adjustment. This is a normal situation.
  3. The internal pilot type uses a metal contact seal on the pilot regulator portion that causes it to bleed a slight amount of air. This is a normal situation.

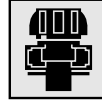

### Residual Pressure Exhaust Valve

#### Mounting and piping

1. When mounting the Residual Pressure Exhaust Valve as a single unit, use either a mounting thread on the R port side or a bracket (optional). If using steel piping, the piping itself can serve as a support.
2. Connect the piping for the Residual Pressure Exhaust Valve so that the P port is on the primary (media) side and the A port is on the mechanical device side. If using as a 2-port valve, use a Rc1/4 plug to block the R port.

- Cautions:**
1. The unit cannot be used with the P port and A port in reversed positions.
  2. If using in locations subject to dripping water, dripping oil, etc., or to large amounts of dust, use something to cover and protect the unit.

#### Switching valves

To switch between air supply or exhaust, rotate the knob by 90 degrees. Rotation to the left (counterclockwise direction) switches to the air supply state, while rotating to the right (clockwise direction) switches to the exhaust state. As there is no neutral position (where the P port air would return back to A or R), slowly rotating the knob can slowly increase the supply or exhaust volume. To determine the current valve state, check a display window on the side of the knob.

#### Air supply

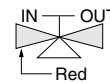

#### Exhaust

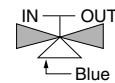

**Caution:** After switching the knob firmly by 90 degrees, always check that it is locked in place.



### General precautions

1. Always thoroughly blow off (use compressed air) the tubing before piping. Entering chips, sealing tape, rust, etc., generated during piping work could result in air leaks or other defective operation.
2. Use clean air for the media. Install an air filter (with filtration of a minimum 5 $\mu$ m). For the use of any other media, consult us.
3. The product cannot be used when the media or the ambient atmosphere contains any of the substances listed below.  
Organic solvents, phosphorate acid ester type hydraulic oil, sulphur dioxide, chlorine gas, acids, or alkali.
4. If using in locations subject to dripping water, dripping oil, etc., or to large amounts of dust, use something to cover and protect the unit.