

Smallest Lightest Compact Basic Cylinders

BC Cylinders

Possible to create all assembly processes with just BC cylinders

Wide range of variations from $\phi 6$ [0.236 in] to $\phi 125$ [4.9 in]

NEW Heat resistant specification, clean room specification, with locating pin hole, and more!



NEW Variations!

- Corrosion resistant, heat resistant, scraper specifications
- Clean system compatible cylinders
- With locating pin hole (option)
- Double rod cylinders: Selectable thread type
- Piston rod end shape (order made)

Basic Cylinders



BASIC CYLINDERS

Lightweight & Compact

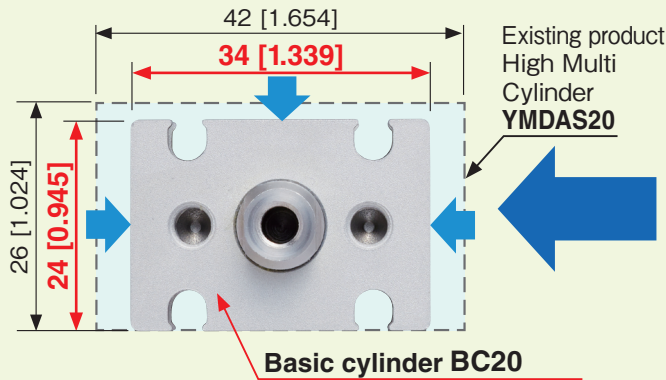

Cross section is **25%** smaller
Total length is **30%** shorter
40% less mass

* Comparison of 10 mm [0.394 in] stroke

Direct mounting

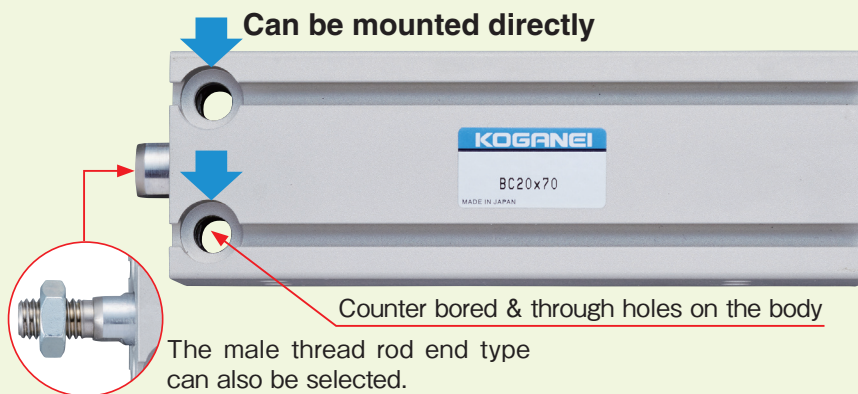

Bracket can be mounted on the head side of $\phi 10$ [0.394] to $\phi 125$ [4.9] models (except when guide is attached)

Bracket material
 $\phi 10$ [0.394] to $\phi 32$ [1.260]: Stainless steel
 $\phi 40$ [1.575] to $\phi 125$ [4.9]: Aluminum alloy

Excellent series ranging from $\phi 6$ to $\phi 125$ [0.236 to 4.9] (Double acting type and double rod cylinders)

H1 grease compatibility as standard **NEW** **150°C [302°F] compatibility for heat resistant standard**

(Compliant with H1 grade food equipment specifications)

Uses NSF H1 grade grease.



CAUTION Read the safety precautions on page 7 before using this product.

Cylinder with guide

φ 8 [0.315], φ 12 [0.472], φ 16 [0.630], φ 20 [0.787], φ 25 [0.984], φ 32 [1.260], φ 40 [1.575]

Linear guide is mounted to save space and for non-rotating accuracy

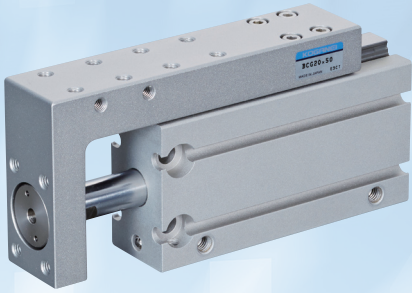

NEW

With locating pin hole (option)

* Main unit three sides, table two sides

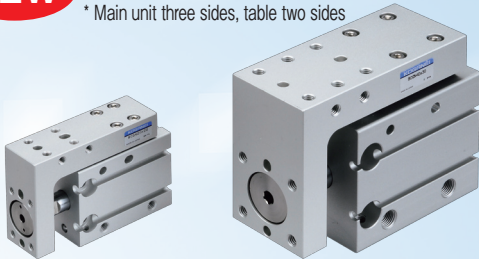

Back side piping is possible

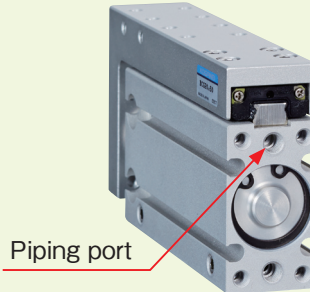

Piping port

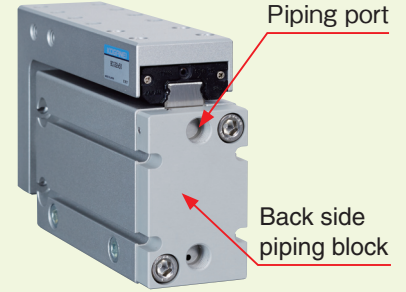

Piping port

Back side piping block

Back side piping is possible as standard for φ 8 [0.315] to φ 25 [0.984] models.

Back side piping is possible for φ 32 [1.260] and φ 40 [1.575] models by selecting back side piping block.

Note: Linear guides use low dust grease.

NEW

Scraper specification

Compatible with environments where dust and water droplets are present.

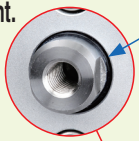

Scraper (NBR)

● Double acting type



NEW

Clean system compatible cylinders

With dust collection port: Class 5 equivalent

Without dust collection port: Class 6 equivalent

● Double acting type



With dust collection port

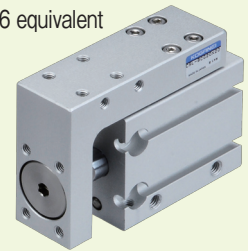

● Cylinder with guide
(Without dust collection port)



φ 63
[2.480 in]



φ 80
[3.150 in]



φ 100
[3.937 in]



φ 125
[4.9 in]

INDEX

Features	1	Double rod end cylinders	77	Piston rod end shape pattern diagrams	133
Safety precautions	7	Cylinder with guide	95	Additional Parts	134
Handling Instructions and Precautions	10	Clean system compatible cylinders	107	Sensor switches	136
Double acting type, single acting push type, single acting pull type	23	Bracket	132		

Step 1 variations

Double acting type 23 Page

$\phi 6$ [0.236] to $\phi 125$ [4.9] ($\phi 6$ [0.236], $\phi 8$ [0.315], $\phi 10$ [0.394], $\phi 12$ [0.472], $\phi 16$ [0.630], $\phi 20$ [0.787], $\phi 25$ [0.984], $\phi 32$ [1.260], $\phi 40$ [1.575], $\phi 50$ [1.969], $\phi 63$ [2.480], $\phi 80$ [3.150], $\phi 100$ [3.9], $\phi 125$ [4.9])
*Double acting type has excellent low-speed operation (range of speeds: 10 to 500 mm/s [0.394 to 19.7 in/sec]).

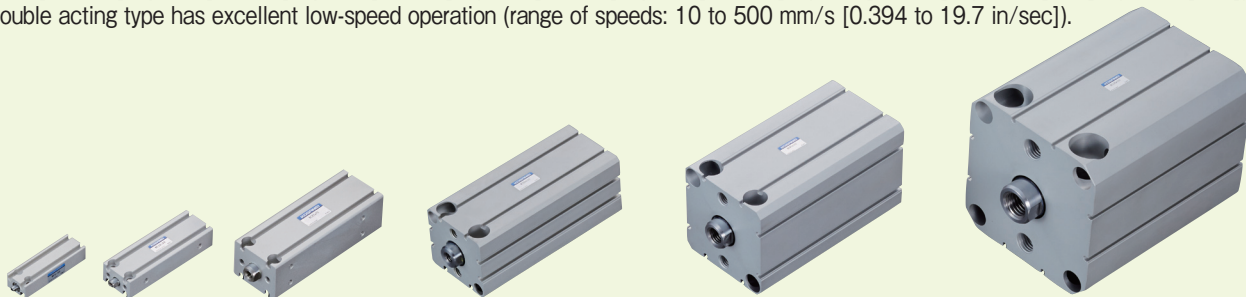

Single acting push type 23 Page

$\phi 6$ [0.236] to $\phi 50$ [1.969]
($\phi 6$ [0.236], $\phi 8$ [0.315], $\phi 10$ [0.394], $\phi 12$ [0.472], $\phi 16$ [0.630], $\phi 20$ [0.787], $\phi 25$ [0.984], $\phi 32$ [1.260], $\phi 40$ [1.575], $\phi 50$ [1.969])

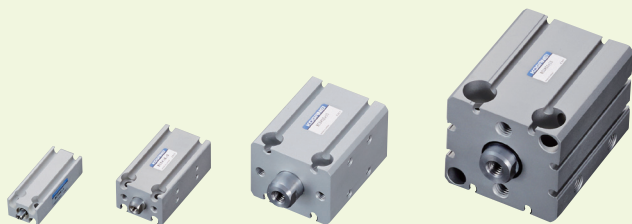

Single acting pull type 23 Page

$\phi 6$ [0.236] to $\phi 50$ [1.969]
($\phi 6$ [0.236], $\phi 8$ [0.315], $\phi 10$ [0.394], $\phi 12$ [0.472], $\phi 16$ [0.630], $\phi 20$ [0.787], $\phi 25$ [0.984], $\phi 32$ [1.260], $\phi 40$ [1.575], $\phi 50$ [1.969])



Double rod end cylinders 77 Page

$\phi 6$ [0.236] to $\phi 125$ [4.9]
($\phi 6$ [0.236], $\phi 8$ [0.315], $\phi 10$ [0.394], $\phi 12$ [0.472], $\phi 16$ [0.630], $\phi 20$ [0.787], $\phi 25$ [0.984], $\phi 32$ [1.260], $\phi 40$ [1.575], $\phi 50$ [1.969], $\phi 63$ [2.480], $\phi 80$ [3.150], $\phi 100$ [3.9], $\phi 125$ [4.9])

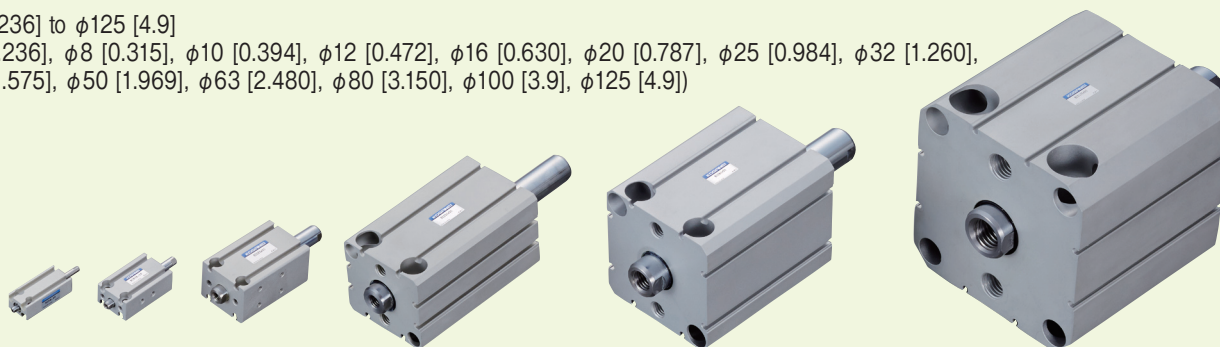

Cylinder with guides 95 Page

$\phi 8$ [0.315] to $\phi 40$ [1.575] ($\phi 8$ [0.315], $\phi 12$ [0.472], $\phi 16$ [0.630], $\phi 20$ [0.787], $\phi 25$ [0.984], $\phi 32$ [1.260], $\phi 40$ [1.575])

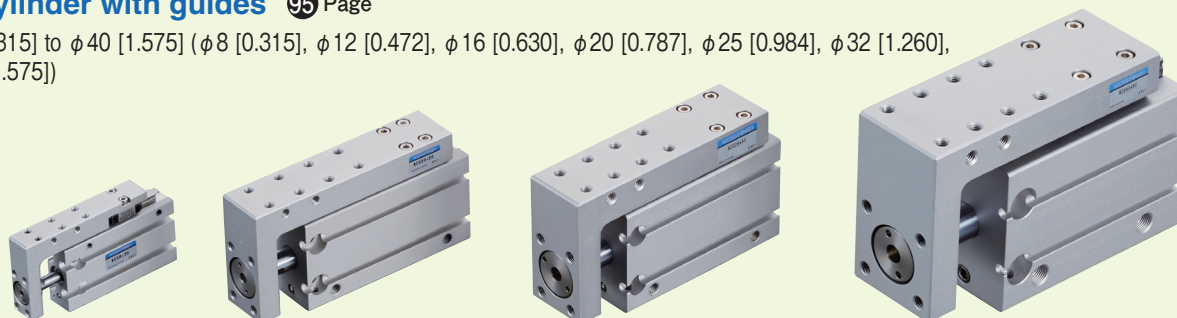

NEW Step 2 variations

◆ Corrosion resistant specification

- Piston rod
- Snap ring: Electroless nickel plated
- Guide: H1 grease • Packing: NBR

Compatible cylinders

- Double acting type $\phi 6$ [0.236] to $\phi 125$ [4.9] 23 Page
- Single acting push type, single acting pull type $\phi 6$ [0.236] to $\phi 50$ [1.969] 23 Page
- Double rod end cylinders $\phi 6$ [0.236] to $\phi 125$ [4.9] 77 Page
- Cylinder with guide $\phi 6$ [0.236] to $\phi 40$ [1.575] 95 Page

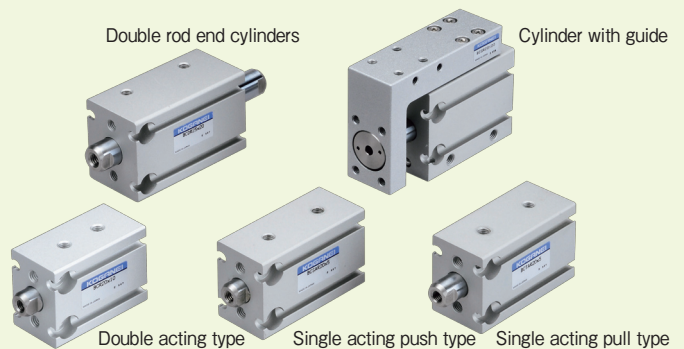

◆ Heat resistant specification

Up to a maximum of 150°C [302 °F].

- Packing: fluoro rubber
- Note: Sensor switch cannot be attached.

Compatible cylinders

- Double acting type $\phi 6$ [0.236] to $\phi 125$ [4.9] 23 Page
- Cylinder with guide $\phi 8$ [0.315] to $\phi 40$ [1.575] 95 Page

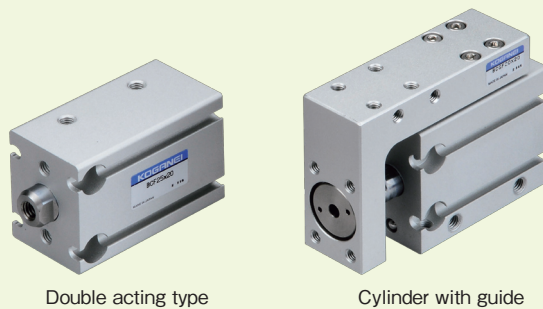

◆ Scraper specification

Compatible with environments where dust and water droplets are present.

Compatible cylinders

- Double acting type $\phi 10$ [0.394] to $\phi 125$ [4.9] (No $\phi 6$ [0.236] and $\phi 8$ [0.315]) 23 Page

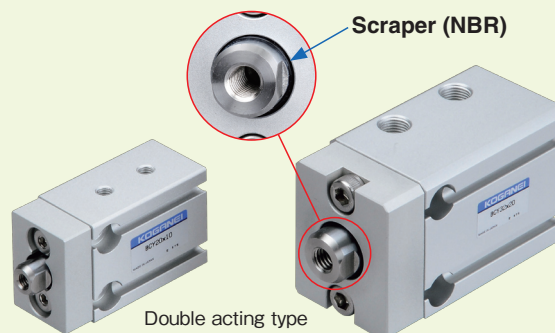

◆ Clean system compatible cylinders

With dust collection port: Class 5 equivalent
Without dust collection port: Class 6 equivalent

Compatible cylinders

- Double acting type (With dust collection port) $\phi 6$ [0.236] to $\phi 63$ [2.480] 107 Page
- Double acting type (Without dust collection port) $\phi 10$ [0.394] to $\phi 63$ [2.480] 107 Page
- Cylinder with guide (Without dust collection port) $\phi 8$ [0.315] to $\phi 40$ [1.575] 121 Page

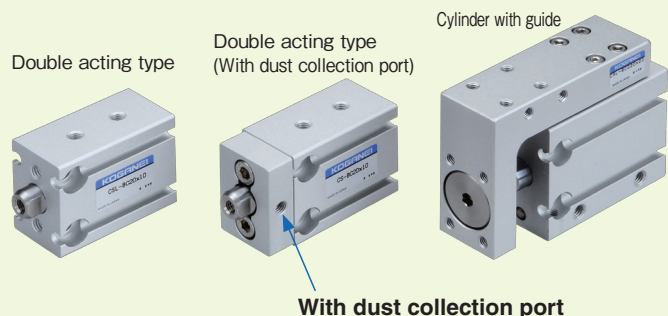

◆ With locating pin hole (option)

Cylinder body: Pin holes in three sides
Table: Pin holes in two sides

Compatible cylinders

- Cylinder with guide $\phi 8$ [0.315] to $\phi 40$ [1.575] 95 121 Page

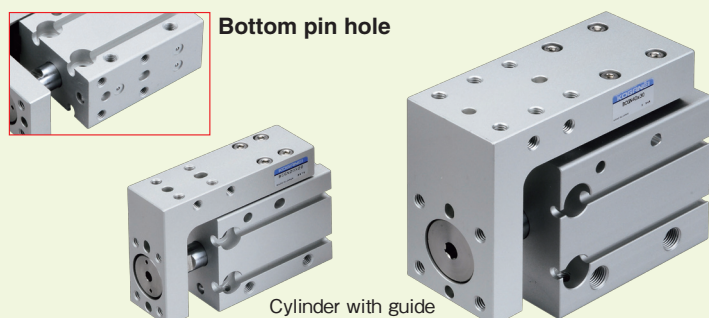

Guide to recommended related products!

For details, see our homepage. <http://www.koganei.co.jp>

F series solenoid valves (F10•F15•F18)

Low-current type and single/double dual-use valves offer energy savings and a low price.

- Switch the manual override button to select single solenoid valve or double solenoid valve functions on the 2-position valve of the F series.
- Different tube sizes for piping are possible with dual-use different size fittings.

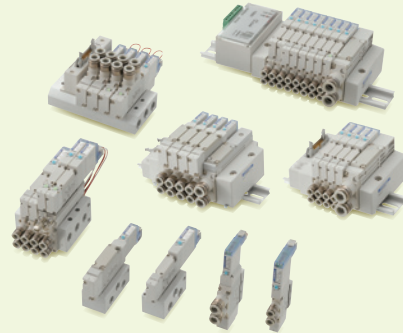

iB-Cyclone

High-speed cyclone type water separator!

- Half the volume ratio and 99% higher moisture separation rate when compared with equivalent equipment.
- No element used for maintenance-free operation.
- Auto drain function (NC and NO) available.
- Specifications for ozone resistance, NCU specifications (copper free) compatible as standard.



Smaller size FRZB filter regulator

FRZB filter regulator with moisture and fluid removal function!

- Compact size with short face-to-face dimensions.
- With drain cock and easy to use moisture and fluid removal function.
- Auto drain function (NC and NO) available.
- Bowl guard available.



FRZ Series Air filter•Oil mist filter•Micromist filter

*Downsized! Short face-to-face dimensions!
Visible filter element!*

- Compact size with short face-to-face dimensions.
- It is easy to check the state of the filter element.
- Auto drain function (NC and NO) available.



Two-color LED sensor switches

Two-color LED sensor switches that can be easily positioned and adjusted. Appropriate operation range can be determined by the color of the LED indicator!

●Explanation of operation

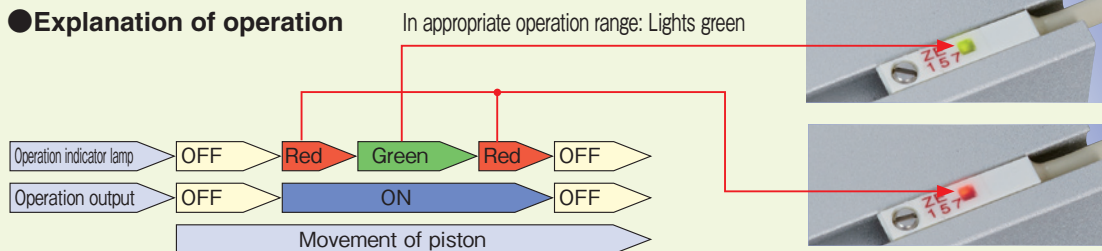

MTV Series water removal valves

Our answer to counteracting condensation! Prevent condensation from developing inside the piping to pneumatic grippers and small cylinders!

- Simply connect it in the pipes! Easy mounting!

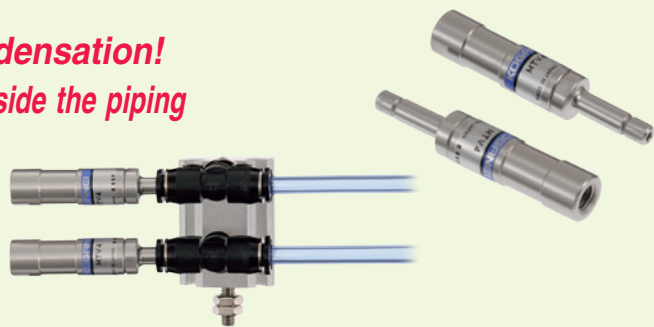

iB-Flow Digital flow controller

Constantly monitors cylinder tact times and adjusts automatically!

- Digitally set cylinder tact times (operation cycle times).
- Tact time controller is always monitoring and adjusting.
- Safety mechanism prevents needle from loosening.
- Numeric setting of needle opening (0 to 100%).

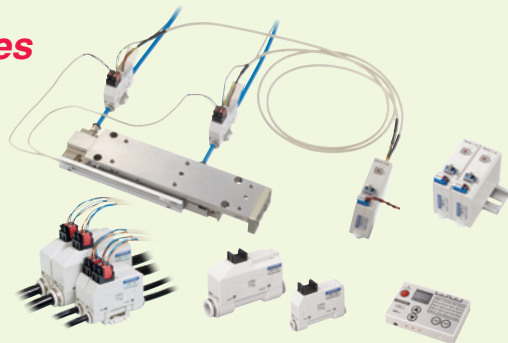

Quick fitting series



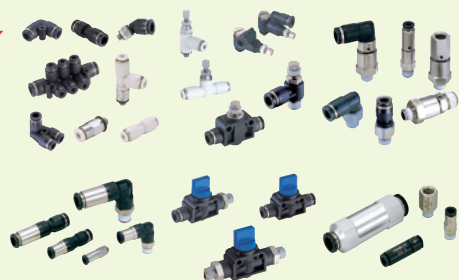

Wide range of variations such as many types of quick fittings and speed controllers with quick fittings!

- Standard types, mini types, and SUS specifications available.
- Diverse variations available such as quick fittings with stop valves, hand valves, check valves, throttle valves, and power reducers.



Before selecting and using the products, please read all the safety precautions carefully to ensure proper product use. The safety precautions described below are to help you use the product safely and correctly, and to prevent injury or damage to you, other people, and assets. Always observe these safety precautions and the following safety regulations: ISO4414 (Pneumatic fluid power - General rules and safety requirements for systems and their components) and JIS B 8370 (General rules relating to systems).

The directions are ranked according to degree of potential danger or damage: "DANGER", "WARNING!", "CAUTION!", and "ATTENTION!".

 DANGER	Indicates situations that can be clearly predicted as dangerous. Death or serious injury may result if the situation is not avoided. It could also result in damage or destruction of assets.
 WARNING	Indicates situations that, while not immediately dangerous, could become dangerous. Death or serious injury may result if the situation is not avoided. It could also result in damage or destruction of assets.
 CAUTION	Indicates situations that, while not immediately dangerous, could become dangerous. Failure to avoid the situation creates the risk of minor or semi-serious injury. It could also result in damage or destruction of assets.
 ATTENTION	While there is no chance of injury, these points should be observed for appropriate use of the product.

■ This product was designed and manufactured for use in general industrial machinery.

- When selecting and handling equipment, the system designer or another person with sufficient knowledge and experience should always read the safety precautions, catalog and other literature before commencing operation. Improper handling is dangerous.
- After reading the catalog, and other documentation, always place them in a location that allows easy availability for reference to users of this product.
- Whenever transferring or lending the product to another person, always attach the catalog, and other information to the product where they are easily visible in order to ensure that the new user can use the product safely and properly.
- The danger, warning and caution items listed under these safety precautions do not cover all possible contingencies. Read the catalog carefully, and always keep safety first.

 **DANGER**

- Do not use the product for the purposes listed below:
 1. Medical equipment related to maintenance or management of human lives or bodies
 2. Machines or equipment designed for the purpose of moving or transporting people
 3. Critical safety components in mechanical devices
This product has not been planned or designed for purposes that require high levels of safety. Using the product in any of the ways described above creates the risk of loss of human life.
- Do not use the product in locations with or near dangerous substances such as flammable or ignitable substances. This product is not explosion-proof. Doing so creates the risk of ignition and fire.
- When mounting the product and workpiece, always make sure they are firmly supported and secured in place. Falling, dropping, or abnormal operation of the product creates the risk of personal injury.
- Persons using a pacemaker or other similar medical devices should maintain a distance of at least one meter [3.28 ft] away from the product. Getting too close to the product creates the risk of malfunction of a pacemaker due to the strong magnet built into the product.
- Never attempt to modify the product in any way. Doing so creates the risk of injury, electric shock, fire, etc. due to abnormal operations.
- Never attempt inappropriate disassembly, assembly or repair of the product relating to basic construction, or to its performance or to functions. Doing so creates the risk of injury, electric shock, fire, etc.
- Do not allow water to splash on the product. Water spraying on the product, washing the product, or using the product under water creates the risk of malfunction, leading to injury, electric shock, fire, etc.
- While the product is in operation, avoid touching it with your hands or otherwise approaching too close. Also, do not attempt to make any adjustments to internal or attached mechanisms (sensor switch mounting location, disconnection of piping tubes or plugs, etc.) while the product is in operation. This may cause an unintended cylinder movement resulting in injury.
- When operating the product, always install speed controllers, and gradually loosen the needle valve from a choked state to adjust the increase in speed. Failure to make this adjustment could result in the air supply causing sudden movements, which may put human lives at risk.

- Do not apply excess bending or buckling force to the piston rod. Doing so may cause abnormal wear or damage to the rod or tube and reduce the product's operating life.
- Always link the direction of motion of the load with the axis of the piston rod. If they are not the same, the undue force on the tube and piston rod may cause abnormal wear or damage.

 **WARNING**

- Do not use the product in excess of its specification ranges. Doing so creates the risk of product breakdown, loss of function, or damage. It could also drastically reduce the product's operating life.
- Before supplying air or electricity to the device and before starting operation, always conduct a safety check of the area where the machine is operating. Unintentional supply of air or electricity creates the risk of electric shock or injury due to contact with moving parts.
- Do not touch terminals or switches while power is turned on. Doing so creates the risk of electric shock and abnormal operation.
- Always check the catalog and other reference materials for correct product wiring and piping. Improper wiring and piping creates the risk of abnormal operation of the cylinder.
- Do not allow the product to be thrown into fire. Doing so creates the risk of explosion and the release of toxic gases.
- Do not sit on the product, place your foot on it, or place other objects on it. Doing so creates the risk of injury due to tripping or the product tipping over or falling, resulting in product damage, malfunction or runaway operation.
- Before conducting maintenance, inspection, repair, replacement, or any other similar procedure, always completely cut off all air supply and confirm that residual pressure inside the product or in piping connected to the product is zero. In particular, be aware that residual air will still be in the air compressor or storage tank. The cylinder may move abruptly, if residual air pressure remains inside the piping, causing injury.
- Do not use the cylinder as a device to absorb the shock or vibration of machinery. Doing so may create the risk of injury or the breakdown of the machinery.
- Do not allow lead wires of sensor switches or other cords to become damaged. Allowing a cord to become damaged, bent excessively, pulled, rolled up, placed under heavy objects, or squeezed between two objects creates the risk of current leaks or defective continuity that can lead to fire, electric shock, or abnormal operation.

- Do not apply external magnetic field to sensor switches while the cylinder is in operation. Unintended operations could damage equipment or cause injury.
- Use the product within the recommended load and operating speed specifications. Using the cylinder in excess of the recommended load and operating speed specifications could damage the cylinder causing damage to equipment or injury.
- Use safety circuits or design a system that prevents damage to machinery and personal injury when the machine is shut down due to an emergency stop or electrical power failure, etc.
- Install relief valves or other devices to ensure that the cylinder does not exceed its rated pressure when the pressure is increased by external forces on the cylinder. Excessive pressure could lead to a breakdown and damage.
- When the product has been idle for over 48 hours or has been in storage, it is possible that the contacting parts may have become stuck leading to operating delays or sudden movements. Before initial operations, always run a test to check that operating performance is normal.
- Do not use the product near the ocean, in direct sunlight, near mercury vapor lamps, or near equipment that generates ozone. Deterioration of rubber parts caused by ozone may reduce performance and functions or stop functions.
- Because Koganei products may be used under a wide variety of conditions, decisions concerning conformance with a particular system should be made upon the careful evaluation by the person in charge of system design. Assurances concerning expected system performance and safety are the responsibility of the designer who decides system conformity. Be sure to use the latest catalogs and technical materials to study and evaluate specification details, to consider the possibility of machine breakdown, and to configure a system that ensures fail-safe safety and reliability.
- Do not apply force to cylinder rods and tables outside the ranges of allowable lateral load, allowable kinetic energy, allowable moment, and other values shown in the catalog and other documentation. Doing so may cause wear or damage to the rod or tube and reduce the product's operating life.

CAUTION

- Do not use the product in locations subject to direct sunlight (ultraviolet radiation), in locations with dust, salt, or iron particles, or in locations with media and/or ambient atmosphere that include organic solvents, phosphate ester type hydraulic oil, sulfur dioxide gas, chlorine gas, acids, etc. Such uses could lead to loss of functions within a short period, sudden degradation in performance, or reduced operating life. For details on materials used in the product, refer to the description of materials used in major parts.
- When mounting the product, leave room for adequate working space around it. Failure to do so will make it more difficult to conduct daily inspections or maintenance, which could eventually lead to system shutdown or damage to the product.
- When transporting or mounting a heavy product, firmly support the product using a lift or support, or use multiple people to ensure personal safety.
- Do not bring any magnetic media or memory within one meter [3.28 ft] of the product. Doing so creates the risk of damage to data on the magnetic media due to magnetism.
- Do not use the sensor switch in locations subject to large electrical currents or strong magnetic fields. It could result in erratic operation.
Also avoid using magnetic material for any parts used for mounting. Doing so creates the risk of magnetism leakage that causes malfunctions.
- Do not bring the product too close to magnetic material. The sensor switch may malfunction or operate erratically if the product is located near a magnet or where a magnetic field is generated.
- Never use another companies' sensor switches with these products.
Doing so may cause malfunctions or runaway operation.
- Do not scratch, dent, or deform the actuator by sitting or standing on the product, or by placing objects on it. Doing so creates the risk of damage to or breakage of the product, resulting in operational shutdown or degraded performance.

- Always post an "operations in progress" sign for installations, adjustments, or other operations, to avoid unintentional supplying of air or electrical power, etc. Unintended power or air supply can cause electric shock and sudden cylinder movement, creating the risk of personal injury.
- Do not subject any cords, such as the sensor switch lead wires, to excessive loads by pulling on them, lifting the product by them, or placing heavy objects on them. Doing so may cause current leakage or defective continuity leading to fire, electric shock, or abnormal operation.
- Using extremely dry air with a dew point lower than -20°C [-4°F], may affect the quality of the lubricating oil used. This may cause loss of functions, shorter operating life, degraded performance or other problems.
- Be sure to wash your hands thoroughly after touching the heat resistant specification and clean room specification grease. Smoking a cigarette with hands soiled with grease creates the risk of emission of toxic gas when grease adhering to the cigarette burns. (Though the grease is very stable at normal temperature, it emits toxic gas when its temperature exceeds 260°C [500°F].)

ATTENTION

- Whenever considering use of this product in situations or environments not specifically noted in the catalog, or in applications where safety is an important requirement such as in aircraft facilities, combustion equipment, leisure equipment, safety equipment, and other places where human life or assets may be greatly affected, take adequate safety precautions such as allowing plenty of margin for ratings and performance, or fail-safe measures.
Be sure to contact Koganei before use in such applications.
- Moving parts of machinery should be isolated with protective covers so as not to come into direct contact with human bodies.
- Do not configure controls that would allow workpieces to fall if power fails.
Configure the control system to prevent workpieces or tables from falling if the machinery stops during an emergency stop or power outage.
- When handling the product, wear protective gloves, safety glasses, safety shoes, and other protective clothing whenever necessary.
- When the product can no longer be used or is no longer necessary, dispose of it appropriately as industrial waste.
- Pneumatic equipment can exhibit degraded performance and function over its operating life. Always conduct daily inspections of the pneumatic equipment, and confirm that all requisite system functions are satisfied, to prevent accidents from happening.
- For inquiries about the product, consult your nearest Koganei sales office or Koganei Overseas Department. The addresses and telephone numbers are shown on the back cover of this catalog.

Other

- Always observe the following items.
 1. When using this product in pneumatic systems, always use genuine Koganei parts or compatible parts (recommended parts).
When conducting maintenance and repairs, always use genuine Koganei parts or compatible parts (recommended parts).
Always observe the prescribed methods and procedures.
 2. Never attempt inappropriate disassembly or assembly of the product in relation to its basic construction, performance, or functions.

Koganei cannot be held responsible for any problems that occur as a result of these safety precautions not being properly observed.



Design and selection

WARNING

1. Check the specifications.

Read the specifications carefully to ensure correct use within the product's specified voltage, current, temperature, and shock ranges, failure to do so could result in a breakdown or defective operation.

2. Be careful when mounting cylinders in close proximity to each other.

Refer to page 94 if you are mounting more than two cylinders, with sensor switches, in parallel. The magnetic field interference may cause the sensor switches to malfunction.

3. Be careful of how long the sensor switch is on when detecting the position in mid-stroke.

Be aware that, when the sensor switch is mounted at an intermediate point of the cylinder stroke to detect the passing of the piston, if the piston is moving too fast, the length of time the sensor switch operates is too short to delete the piston passing (so loads such as programmable controllers are not operated). The highest detectable cylinder speed is

$$V \text{ mm/s [in/sec]} = \frac{\text{Sensor switch operating range mm [in]}}{\text{Time required for load operation [ms]}} \times 1000$$

4. Keep wiring as short as possible.

Lead wires for solid state sensor switches should be within 30 m [98 ft] as stipulated by EN standards. For reed sensor switches, longer wiring (10 m [33 ft] or longer) will lead to a larger capacitive surge, which reduces the operating life of sensor switches. When longer wiring cannot be avoided, provide the protective circuit described in the catalog. For details, see page 93.

If the load is inductive or capacitive, provide the appropriate protective circuit as described in the catalog. For details, see page 93.

5. Avoid repeated bending or excessive pulling of lead wires.

Applying repeated bending stress or tension force on the lead wires could break them.

6. Check for leakage current.

With 2-lead wire solid-state sensor switches, current (leakage current) flows to the load to activate the internal circuit even when turned off. Ensure that the circuit satisfies the following inequality.

Input off current of programmable controller > Leakage current
If the above inequality cannot be satisfied, select a 3-lead wire solid state sensor switch. And, if n sensor switches are connected in parallel, the leakage current increases by n times.

7. Do not use reed sensor switches at low speeds below 30 mm/s [1.2 in/sec]. Doing so may cause erratic operation or loss of functions.

CAUTION

1. Check for internal voltage drop of sensor switches.

Connecting reed sensor switches with indicator lamps, or 2-lead wire solid state sensor switches, in series causes increasing internal voltage drop and the load may fail to activate. Connecting n switches will drop the internal voltage by n times as much.

Ensure that the circuit satisfies the following inequality:

$$\text{Supply voltage} - \text{Internal voltage drop} \times n > \text{Minimum operating voltage of the load}$$

In relays with rated voltage of less than 24 VDC, check that the above inequality is satisfied even when n=1.

If the above inequality cannot be satisfied, select a reed sensor switch without an indicator lamp.

2. Do not use Koganei sensor switches with other companies' cylinders.

The sensor switches are designed for use with Koganei cylinders only. They may not function correctly if used with other companies' cylinders.



Installation and adjustment

WARNING

1. Do not apply an external magnetic field to the sensor switch while the cylinder is in operation.

This may cause unintended operation, thereby damaging the device or causing injury.

CAUTION

1. Be aware of the environment in which you install the sensors and cylinders.

Do not use the sensor switch in locations subject to large electrical currents or strong magnetic fields. It could result in erratic operation.

Also avoid using magnetic material for any parts used for mounting. It could result in erratic operation.

2. Install sensor switches in the center of their operating range.

Adjust the mounting position of a sensor switch so that the piston stops in the center of its operating range (the range while the sensor is ON). Operations will be unstable if mounted at the end of the operating range (at the boundary near on and off). Also be aware that the operating range will vary with changes in temperature.

3. Follow the tightening torque guidelines for mounting sensor switches.

Over-tightening beyond the allowed tightening torque may damage the mounting threads, mounting brackets, sensor switches and other components. However, insufficient tightening torque may cause the sensor switch position to change, resulting in unstable operation. Follow the instructions on page 11 concerning the tightening torque.

4. Do not carry the cylinder by its mounted sensor switch's lead wires.

After mounting a sensor switch on the cylinder, do not carry the cylinder by grabbing the lead wires. Never do this, as it may damage not only the lead wires but may also apply stress to the inside of the sensor switch that may damage internal elements.

5. Do not drop the sensor switches or bump them against other objects.

While handling sensor switches, do not subject them to excessive shock (294.2 m/s² [30 G] or larger) by hitting, dropping or bumping them.

In the case of reed sensor switches, such behavior may cause the contact to malfunction, thereby giving a signal output or turning off the signal instantaneously. And, this may change the contact interval, thereby deteriorating the sensor switch's sensitivity. As such, this may cause the device to malfunction. Even if the sensor switch case is not damaged, the inside of the sensor switch may be damaged, causing erratic operation.

Safety Precautions (Sensor Switches)



Wiring

DANGER

1. Prevent nearby moving objects from coming into contact with sensor switches.

When cylinders equipped with sensor switches are moving or when moving objects are nearby, do not let them come into contact with each other. In particular, lead wires may become worn or damaged causing unstable operation of the sensor switch. In the worst case, this may result in current leaks or electrical shock.

2. Always turn off the power before doing wiring work.

Doing wiring work while the power is on may result in electric shock. Also, incorrect wiring could damage the sensor switch in an instant. Turn on the power only after the wiring work is complete.

WARNING

1. Check the catalog and other materials to ensure that the sensor switch is wired correctly.

Incorrect wiring may result in abnormal operation.

2. Do not share wiring with power or high voltage lines.

Avoid wiring in parallel to or in the same conduit with power lines and high-voltage lines. Noise from such wiring could cause the sensor switch and control circuit to operate erratically.

3. Avoid repeated bending or excessive pulling of lead wires.

Applying repeated bending stress or tension force on the lead wires could break them.

4. Check the wiring polarity.

Be sure that the wiring connections are correct for sensor switches that specify polarity (+, -, output). Incorrect polarity could result in damage to sensor switches.

CAUTION

1. Avoid short circuiting loads.

Turning on the sensor switch while the load is short-circuited causes overcurrent, which will damage the sensor switch in an instant.

Example of short-circuit load: Sensor switch's output lead wire is directly connected to the power supply.

2. Position sensor switches in the center of their operating range.

Operating output may be unstable, depending on the operating environment, if positioned at the edge of the operating range.

3. Solid state sensor switches that are compliant with the EMC standards (EN61000-6-2 and EN60947-5-2) are not resistant to surges from lightning. Use countermeasures on the machine to protect them from lightning surges.

4. Use an internal element to absorb surges for direct activation of loads that generate surges.

Handling Instructions and Precautions



General precautions

Piping

Before installing piping to the cylinder, thoroughly flush the inside of the pipes (with compressed air). Machining chips, sealing tape, rust and other debris remaining from the piping work may result in air leaks and malfunctions.

Air supply

1. Use air as the medium. For the use of any other medium, consult your nearest Koganei sales office.
2. Air used for the cylinder should be clean air that contains no degraded compressor oil, etc. Install an air filter (filtration of 40 μm or less) near the cylinder or valve to remove dust and accumulated liquid. Also drain the air filter periodically. If liquid or dust gets into the cylinder, it may cause defective operation.

Lubrication

The cylinder can be used without lubrication, however, if lubrication, such as a lubricator, is used, use turbine oil type 1 (ISO VG32) or an equivalent. Avoid using spindle oil or machine oil.

Environment

1. Cover the unit when using it in locations where it might be subject to excessive dust, dripping water, dripping oil, etc.
2. Do not use the cylinder in environments which may be corrosive. Using the cylinder in these types of environments may result in damage or defective operation
3. Do not use it in excessively dry conditions.
4. Do not use the cylinder if the ambient temperature is over 60°C [140°F], doing so may result in damage or defective operation. Also, consider anti-freezing measures if the temperature is less than 5°C [41°F], because moisture may freeze and result in damage or defective operation.

Handling

1. Do not place your hands in the way of the cylinder when it is operating.
2. Be careful that no part of your body is pinched between the end plate and the cylinder body when the cylinder is retracting.
3. Confirm that there is no pressurized air in the cylinder before starting maintenance work.
4. Use the cylinder within its operating speed range. Even if the speed is within the allowable range, install an external stopper to prevent directly impacting the cylinder, if the load is large or the allowable kinetic energy is exceeded.
5. Use a separate cushioning device, such as a shock absorber, if noise or vibration is an issue.

Warranty and General Disclaimer

1. Warranty Period

The warranty period for Koganei products is 180 days from the date of delivery.

2. Scope of Warranty and General Disclaimer

(1) The Koganei product warranty covers individual products. When a product purchased from Koganei or from an authorized Koganei distributor malfunctions during the warranty period in a way that is attributable to Koganei responsibility, Koganei will repair or replace the product free of charge. Even if a product is still within the warranty period, its durability is determined by its operation cycles and other factors. Contact your nearest Koganei sales office or the Koganei overseas department for details.

(2) Koganei shall not be held responsible for any losses or for any damage to other machinery caused by breakdown, loss of function, or loss of performance of Koganei products

(3) Koganei shall not be held responsible for any losses due to use or storage of the product in a way that is outside of the product specifications prescribed in Koganei catalogs and instruction manuals, and/or due to actions that violate the mounting, installation, adjustment, maintenance or other safety precautions.

(4) Koganei shall not be held responsible for any losses caused by breakdown of the product due to factors outside the responsibility of Koganei, including but not limited to fire, natural disaster, the actions of third parties, and intentional actions or errors by you.

Handling Instructions and Precautions



General precautions

Other

The piston of the single acting type may not retract (return) even when the air is exhausted if air is continuously supplied to the piping port so that its spring is left compressed for a long period (more than 48 hours). Use a double acting cylinder if it will be left unused for long periods such as this.

About the circuit to prevent rod pop-out

Rod pop-out prevention circuit

Using the cylinder in combination with the speed controller shown in the following diagram is effective for controlling speed and preventing rod pop-out.

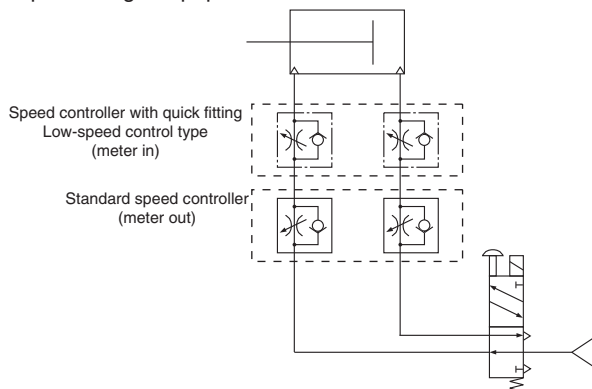

Note: Install the speed controller as close as possible to the cylinder.



Mounting

Mounting

- The cylinder can be mounted in any orientation, but the mounting surface must be flat. If the cylinder twists or bends when mounted, not only will it be inaccurate, but there may be air leaks and defective operation.
- Note that a mounting surface that is scratched or dented can adversely affect flatness.
- If the cylinder is subject to large impacts, use a support structure, such as brackets, to hold the cylinder body in addition to the mounting bolts.
- Be sure that the cylinder body and the mounting bolts are of sufficient strength.
- In cases where loosening of screws due to impact and/or vibration may be a factor, consider looseness prevention measures.
- Do not scratch or dent the sliding parts of the piston rod. Doing so could damage the packing and cause air leaks.
- The piston rod and linear guides are coated with grease, do not wipe it off. Doing so may cause defective operation. If you cannot see the lubricant, apply some grease.
The grease to be used depends on the specification. Contact Koganei for details.
- Note that you cannot use the tapped holes on the front-surface (rod side) of the cylinder if you mount it using the counterbored holes on the cylinder body.
(Double acting type, single acting push type, single acting pull type, and double acting double rod end type from $\phi 10$ [0.394 in] to $\phi 32$ [1.260 in])
- If you are using a combination of a cylinder and guide, use cylinder joints for flexible connections.

Mounting with brackets

We recommend using brackets for mounting if you are using the cylinder in the following conditions. (BCZ-BK□ or -BK)

- Stroke : If using a cylinder with a longer than standard stroke.
- Mounting : If using a vertical or ceiling mount for a cylinder with a long stroke (guideline: Products with bore of $\phi 20$ [0.787 in] or greater and stroke of 50 mm [1.97 in] or longer).
- Process : If using a cylinder for large static loads, such as for pressing processes.
- Other : If using a cylinder in a location subject to extreme vibrations.

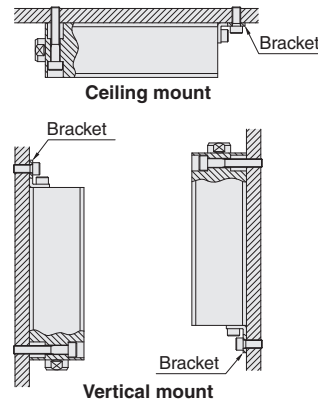

Tightening torque lists

●Fittings

Thread size	Tightening torque
M3×0.5	0.7 [6.196]
M5×0.8	1.0 to 1.5 [8.851 to 13.277]
R1/8	7 to 9 [61.957 to 79.659]
R1/4	12 to 14 [106.212 to 123.914]
R3/8	22 to 24 [194.722 to 212.424]

●Workpiece mounting (Cylinder with guide)

Thread size	Tightening torque
M3×0.5	0.63 [5.576]
M4×0.7	1.5 [13.277]
M5×0.8	3.0 [26.553]
M6×1	5.2 [46.025]

●Plugs (Cylinder with guide)

Thread size	Tightening torque
M3×0.5	0.3 [2.655]
M5×0.8	0.4 [3.540]

●Cylinder & bracket mounting

Thread size	Tightening torque	
	Cylinder	Bracket
M3×0.5	1.2 [10.621]	
M4×0.7	2.7 [23.898]	
M5×0.8	5.4 [47.795]	
M6×1	9.2 [81.429]	
M8×1.25	22 [194.722]	
M10×1.5	44 [389.444]	
M12×1.75	76 [672.676]	
M16×2	190 [1681.7]	
M20×2.5	370 [3274.9]	

*For both mounting to cylinder or to a mating surface.

●Sensor switch mounting

Screw tightening torque: 0.1 N·m to 0.2 N·m [0.885 in·lbf to 1.770 in·lbf]

Handling Instructions and Precautions

Mounting workpiece to cylinder with guide

- The table is supported by the linear guide, so be careful to avoid strong impact and excess moment when mounting workpieces.
- Hold the table when securing the workpiece to the table with bolts. If you hold the body when tightening the bolts, it reduces the precision by applying too large moment on the guide.

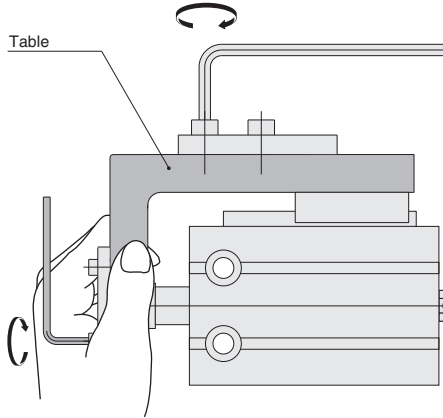

List of recommended mounting bolts

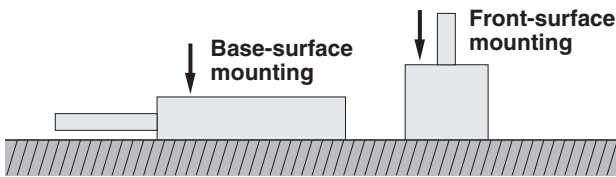

Base-surface mounting

- Double acting type ● Single acting type (push, pull) ● Double rod ● With guide

Cylinder bore mm [in]	Recommended mounting bolts
6 [0.236]	M3 × 12 [0.472]
8 [0.315]	M3 × 12 [0.472]
10 [0.394]	M3 × 16 [0.630]
12 [0.472]	M4 × 16 [0.630]
16 [0.630]	M4 × 20 [0.787]
20 [0.787]	M5 × 25 [0.984]
25 [0.984]	M5 × 30 [1.181]
32 [1.260]	M6 × 35 [1.378]
40 [1.575]	M8 × 45 [1.772]
50 [1.969]	M10 × 55 [2.165]
63 [2.480]	M12 × 65 [2.559]
80 [3.150]	M12 × 80 [3.150]
100 [3.937]	M16 × 110 [4.331]
125 [4.921]	M20 × 130 [5.118]

Use bolts longer than those in the table above when fastening the cylinder.

Front-surface mounting

- Double acting type ● Single acting type (push, pull) ● Double rod

Cylinder bore mm [in]	Recommended mounting bolts		
	Double acting type	Single acting type	Double rod
50 [1.969]	M6×35 [1.378] + stroke	M6×55 [2.165] + stroke	M6×45 [1.772] + stroke
63 [2.480]	M8×40 [1.575] + stroke	—	M8×50 [1.969] + stroke
80 [3.150]	M10×45 [1.772] + stroke	—	M10×55 [2.165] + stroke
100 [3.937]	M10×55 [2.165] + stroke	—	M10×55 [2.165] + stroke
125 [4.921]	M12×55 [2.165] + stroke	—	M12×55 [2.165] + stroke

Use bolts longer than those in the table above when fastening the cylinder.

Allowable kinetic energy (except cylinder with guide)

Use less kinetic energy on the cylinder than indicated in the table below.

Cylinder bore mm [in]	Allowable kinetic energy J [ft·lbf]	
	Double acting, double rod	Single acting (push & pull)
6 [0.236]	0.008 [0.006]	0.004 [0.003]
8 [0.315]	0.014 [0.010]	0.007 [0.005]
10 [0.394]	0.022 [0.016]	0.012 [0.009]
12 [0.472]	0.032 [0.024]	0.017 [0.013]
16 [0.630]	0.057 [0.042]	0.03 [0.022]
20 [0.787]	0.09 [0.066]	0.05 [0.037]
25 [0.984]	0.14 [0.103]	0.08 [0.059]
32 [1.260]	0.23 [0.170]	0.13 [0.096]
40 [1.575]	0.36 [0.266]	0.21 [0.155]
50 [1.969]	0.56 [0.413]	0.32 [0.236]
63 [2.480]	0.89 [0.656]	—
80 [3.150]	1.4 [1.033]	—
100 [3.937]	2.2 [1.623]	—
125 [4.921]	3.5 [2.582]	—

- Use the following equation to calculate the kinetic energy of loads.

$$E_x = \frac{m}{2} v^2$$

E_x : Kinetic energy (J)

m : Mass of load (kg)

v : Piston speed (m/s)

$$E'_x = \frac{W'}{2g'} v'^2$$

E'_x : Kinetic energy [ft·lbf]

W' : Load weight [lb]

v' : Piston speed [ft/sec]

g' : Gravity acceleration 32.2 [ft/sec²]

Allowable lateral load (except cylinder with guide)

Apply less than the maximum lateral load to the cylinder than indicated in the table below.

Equation

- $\phi 6$ [0.236] to $\phi 12$ [0.472], $\phi 50$ [1.969] to $\phi 125$ [4.9]

$$\text{Maximum allowable lateral load } W \leq \frac{l_2 - A}{l_1 + l_2 + St} \cdot R$$

- $\phi 16$ [0.630] to $\phi 40$ [1.575]

$$\text{Maximum allowable lateral load } W \leq \frac{l_2}{l_1 + l_2 + St} \cdot R$$

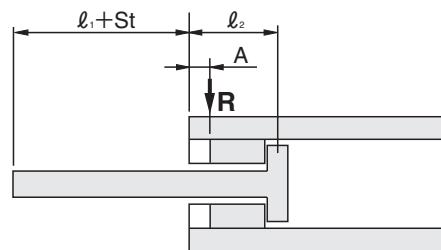

Cylinder bore mm [in]	Allowable lateral load R N [lbf]	l_1 mm [in]	l_2 mm [in]	A mm [in]
6 [0.236]	1.0 [0.225]	4.0 [0.157]	13.8 [0.543]	3.8 [0.150]
8 [0.315]	1.8 [0.405]	4.0 [0.157]	14.3 [0.563]	4.3 [0.169]
10 [0.394]	2.7 [0.607]	4.0 [0.157]	14.4 [0.567]	4.3 [0.169]
12 [0.472]	4.0 [0.899]	5.0 [0.197]	14.0 [0.551]	3.5 [0.138]
16 [0.630]	7.0 [1.574]	5.0 [0.197]	15.0 [0.591]	—
20 [0.787]	11.0 [2.473]	6.0 [0.236]	17.5 [0.689]	—
25 [0.984]	17.2 [3.867]	6.0 [0.236]	18.0 [0.709]	—
32 [1.260]	28.1 [6.317]	7.0 [0.276]	18.5 [0.728]	—
40 [1.575]	44.0 [9.892]	7.0 [0.276]	23.0 [0.906]	—
50 [1.969]	68.7 [15.444]	8.0 [0.315]	27.3 [1.075]	8.0 [0.315]
63 [2.480]	109.1 [24.5]	8.0 [0.315]	33.0 [1.299]	8.0 [0.315]
80 [3.150]	175.9 [39.5]	10.0 [0.394]	32.5 [1.280]	8.0 [0.315]
100 [3.937]	274.9 [61.8]	12.0 [0.472]	44.5 [1.752]	9.0 [0.354]
125 [4.921]	429.5 [96.6]	16.0 [0.630]	50.0 [1.969]	9.0 [0.354]

Handling Instructions and Precautions

Cylinder with guide, allowable kinetic energy

① $\phi 8$ [0.315] to $\phi 20$ [0.787] J [ft·lbf]

Model	BCG□8	BCG□12	BCG□16	BCG□20
Allowable kinetic energy J [ft·lbf]	0.0084 [0.006]	0.0084 [0.006]	0.020 [0.015]	0.044 [0.032]

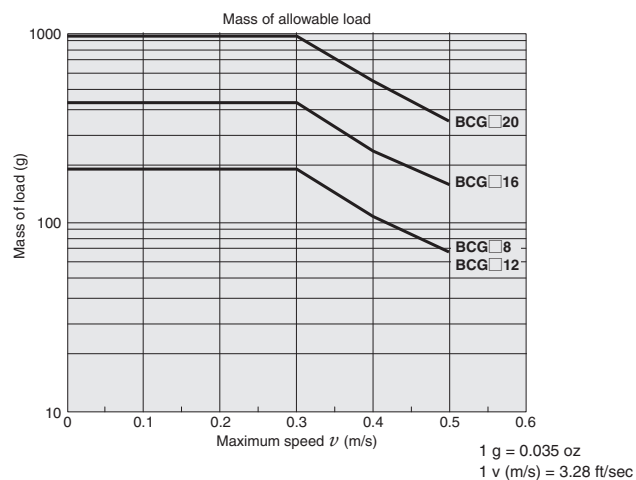

② $\phi 25$ [0.984] to $\phi 40$ [1.575] J [ft·lbf]

Model	BCG□25	BCG□32	BCG□40
Allowable kinetic energy J [ft·lbf]	0.051 [0.038]	0.082 [0.060]	0.134 [0.099]

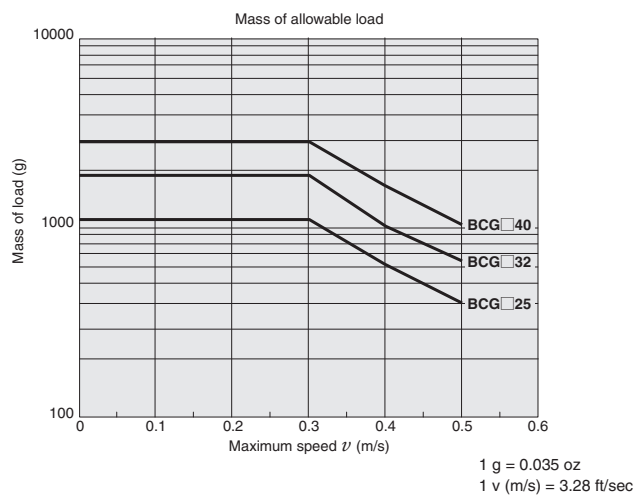

Handling Instructions and Precautions

Allowable bending moment for cylinder with guide

Applying more than the allowable bending moment causes the guide to rattle, reduces precision, and has a bad effect on operating life.

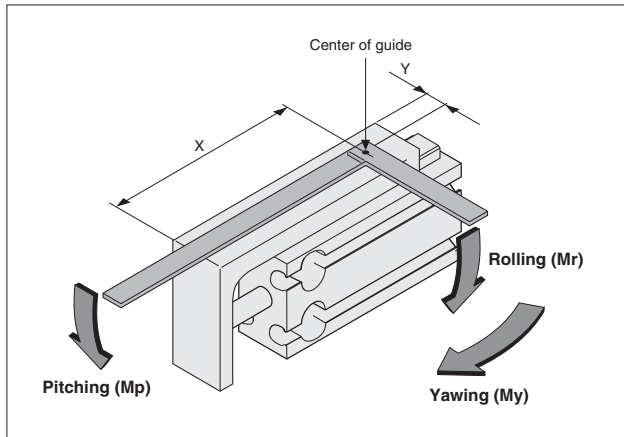

● Use the center of the guide as shown in the diagram as the reference for the center of moment.

● Dimensions of center of guide mm [in]

Model	Stroke	X	Y	Model	Stroke	X	Y
BCG□8	5	31.5	6 [0.236]	BCG□25	5	47.5	14.5 [0.571]
	10	[1.240]			10	[1.870]	
	15	41.5			15	57.5	
	20	[1.634]			20	[2.264]	
	25	51.5			25	67.5	
	30	[2.028]			30	[2.657]	
	35	61.5			35	77.5	
	40	[2.421]			40	[3.051]	
	45	71.5			45	87.5	
	50	[2.815]			50	[3.445]	
BCG□12	5	32.5	7.5 [0.295]	BCG□32	10	57	18 [0.709]
	10	[1.280]			15	67	
	15	42.5			20	[2.638]	
	20	[1.673]			25	77	
	25	52.5			30	[3.031]	
	30	[2.067]			35	87	
	35	62.5			40	[3.425]	
	40	[2.461]			45	97	
	45	72.5			50	[3.819]	
	50	[2.854]			55	107	
BCG□16	5	37.5	9.5 [0.374]	BCG□40	10	70.5	23 [0.906]
	10	[1.476]			15	[2.776]	
	15	47.5			20	80.5	
	20	[1.870]			25	[3.169]	
	25	57.5			30	90.5	
	30	[2.264]			35	[3.563]	
	35	67.5			40	100.5	
	40	[2.657]			45	[3.957]	
	45	77.5			50	110.5	
	50	[3.051]			55	[4.350]	
BCG□20	5	44	11.5 [0.453]				
	10	[1.732]					
	15	54					
	20	[2.126]					
	25	64					
	30	[2.520]					
	35	74					
	40	[2.913]					
	45	84					
	50	[3.307]					
55	94						
60	[3.701]						

Allowable bending moment

N·m [in·lbf]

Model	Mp (pitching)	Mr (rolling)	My (yawing)
BCG□8, BCG□12	0.12 [1.062]	0.12 [1.062]	0.21 [1.859]
BCG□16	0.4 [3.540]	0.4 [3.540]	0.68 [6.019]
BCG□20	1.5 [13.277]	1.8 [15.932]	2.2 [19.472]
BCG□25	2.18 [19.295]	2.18 [19.295]	4.18 [36.997]
BCG□32	4.46 [39.475]	4.46 [39.475]	7.31 [64.701]
BCG□40	6.7 [59.302]	8 [70.808]	13.7 [121.259]

Heat resistant specification

N·m [in·lbf]

Model	Mp (pitching)	Mr (rolling)	My (yawing)
BCGF8, BCGF12	0.11 [0.974]	0.11 [0.974]	0.18 [1.593]
BCGF16	0.35 [3.098]	0.35 [3.098]	0.60 [5.311]
BCGF20	0.88 [7.789]	0.88 [7.789]	1.25 [11.064]
BCGF25	1.37 [12.126]	1.21 [10.710]	2.30 [20.357]
BCGF32	3.56 [31.510]	2.99 [26.464]	6.00 [53.106]
BCGF40	6.32 [55.938]	5.30 [46.910]	11.04 [97.715]

Handling Instructions and Precautions

Displacement of table due to bending moment for cylinder with guide (reference values) For heat resistant specification graphs, refer to page 18.

● Pitching (Mp)

Displacement of edge of table (arrow) when load W is applied at arrow

(Precaution: There may be a large increase in the displacement after a large impact load is applied to the table)

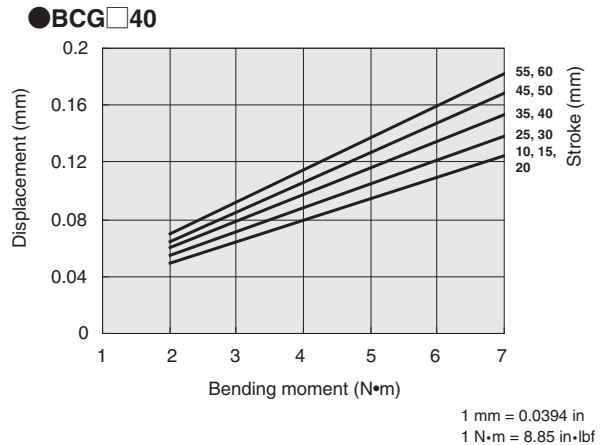
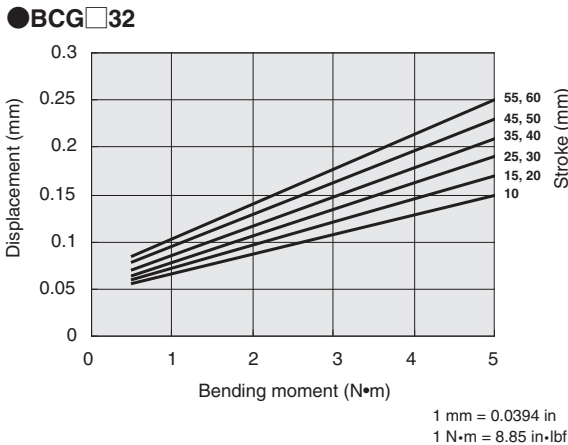
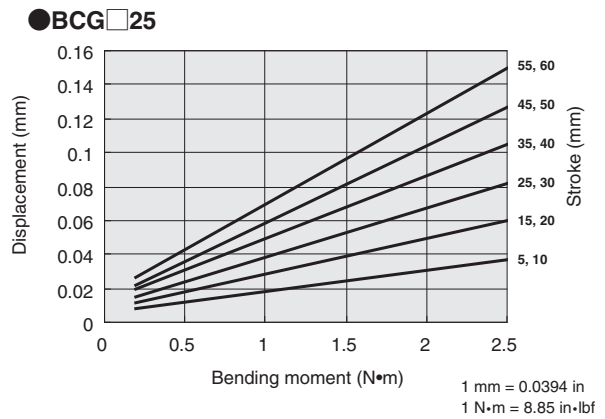
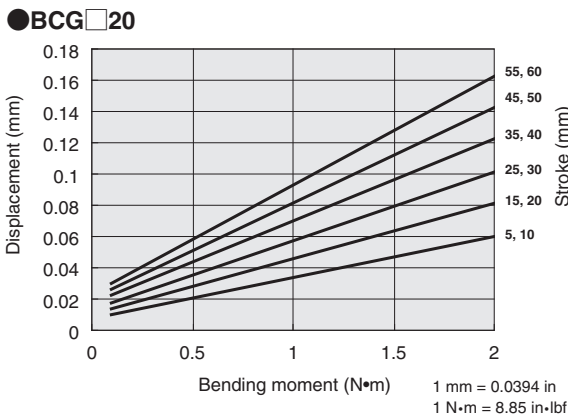
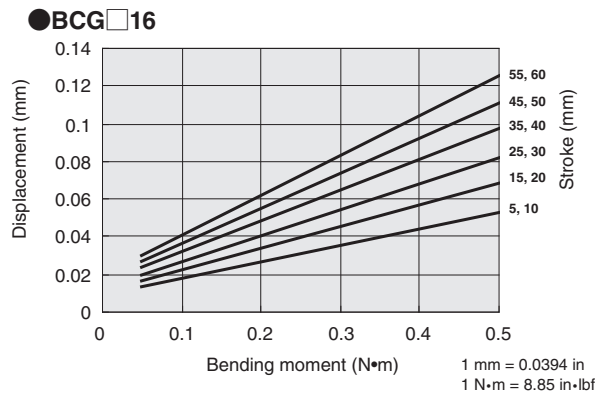
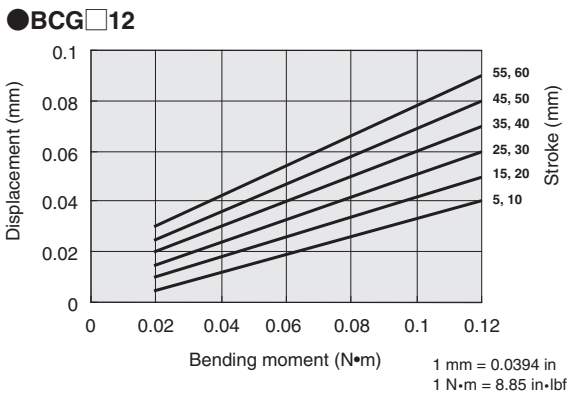
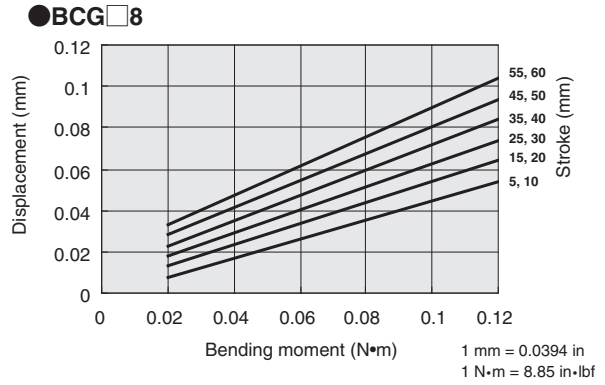
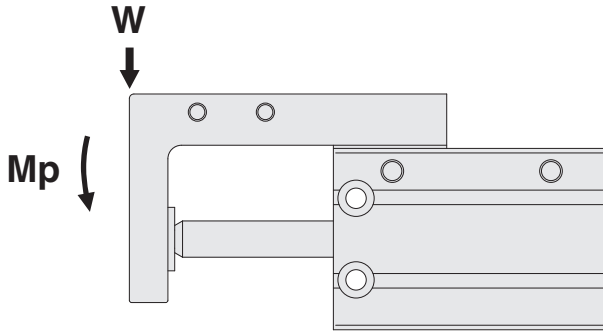

Handling Instructions and Precautions

Displacement of table due to bending moment for cylinder with guide (reference values) For heat resistant specification graphs, refer to page 19.

● Yawing (My)

Displacement of edge of table (arrow) when load W is applied at arrow

(Precaution: There may be a large increase in the displacement after a large impact load is applied to the table)

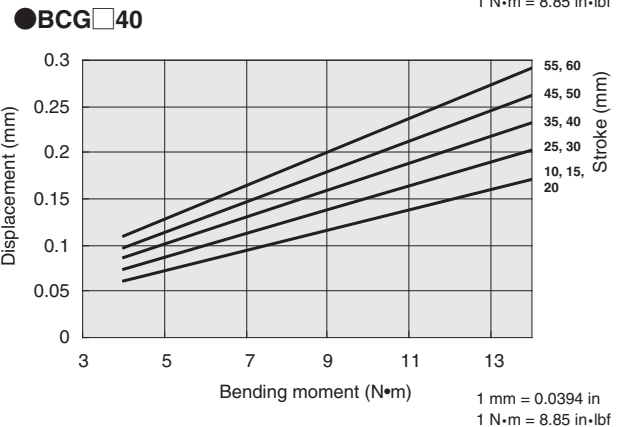
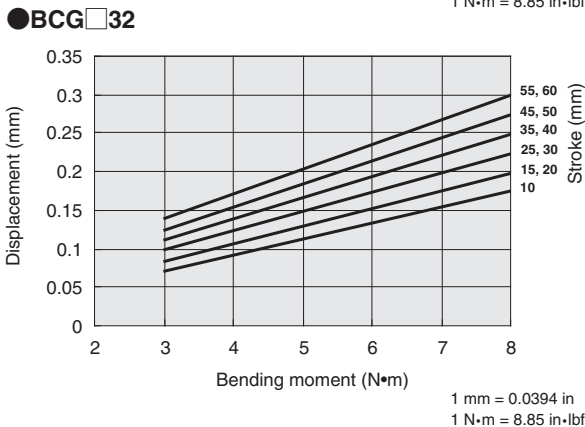
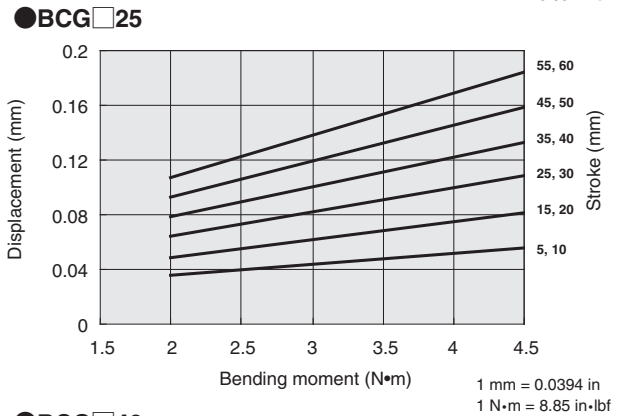
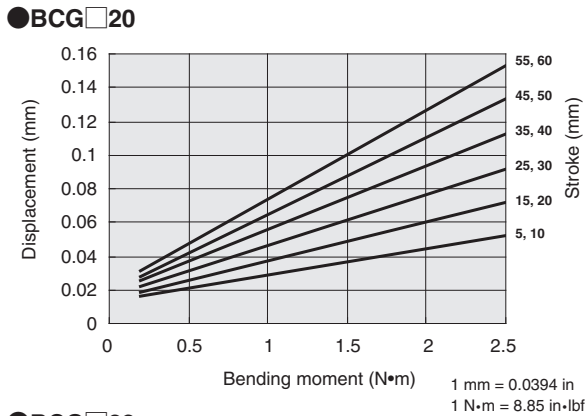
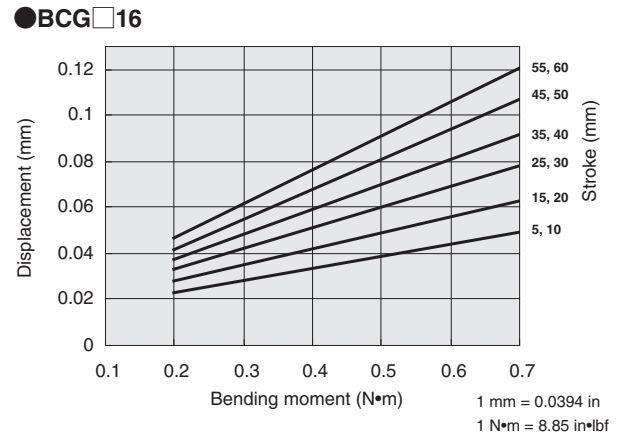
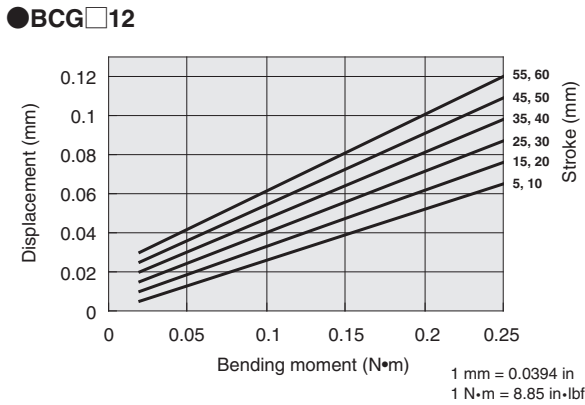
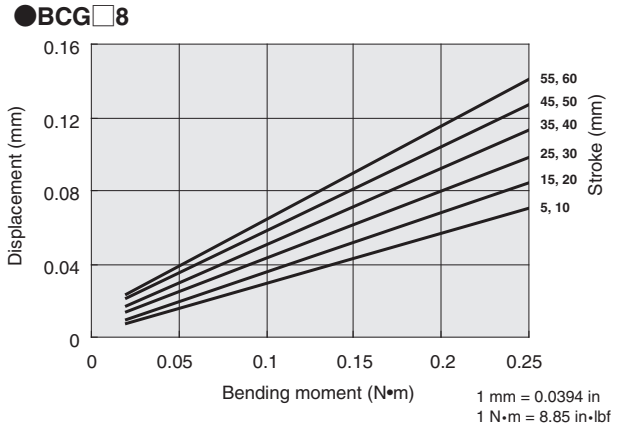
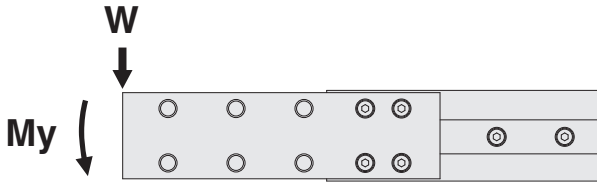

Handling Instructions and Precautions

Displacement of table due to bending moment for cylinder with guide (reference values) For heat resistant specification graphs, refer to page 20.

● **Rolling (Mr)**

Displacement of edge of table (arrow A) when load W is applied at arrow

(Precaution: There may be a large increase in the displacement after a large impact load is applied to the table)

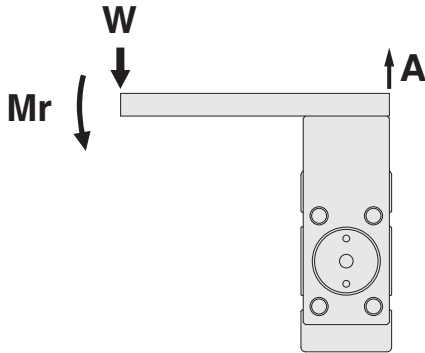

● **BCG□8**

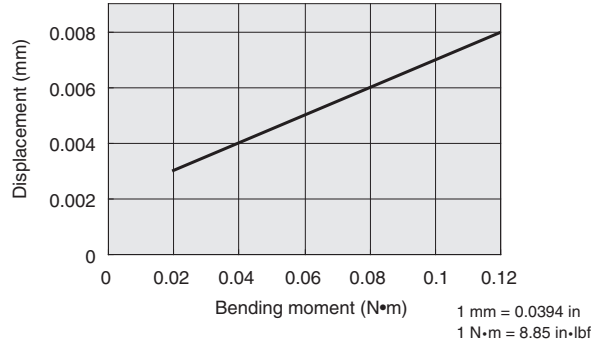

● **BCG□12**

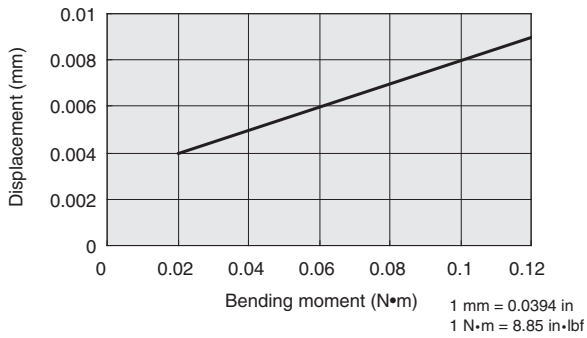

● **BCG□16**

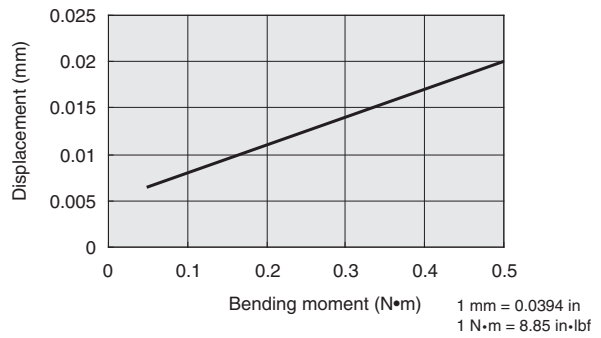

● **BCG□20**

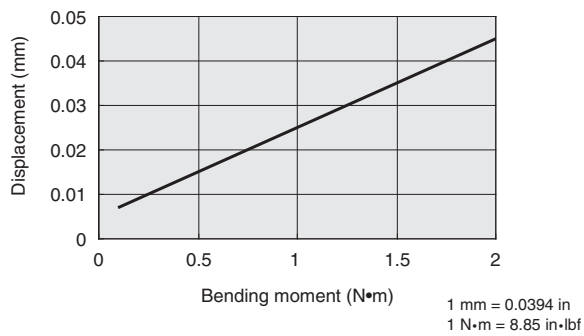

● **BCG□25**

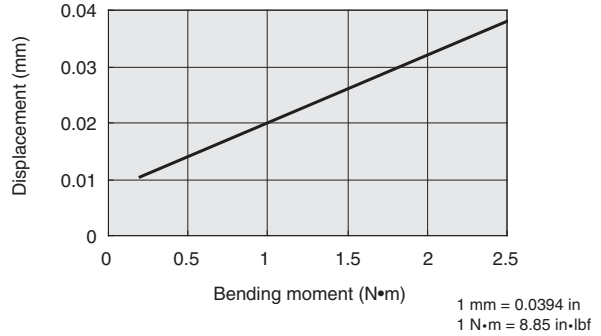

● **BCG□32**

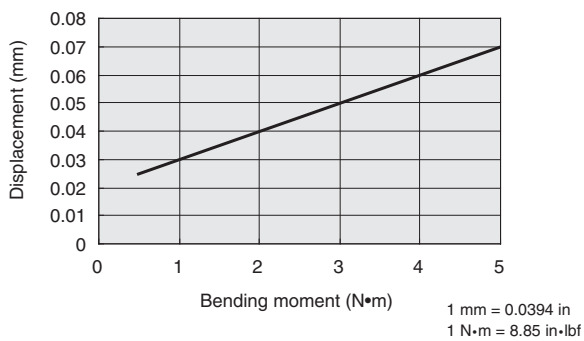

● **BCG□40**

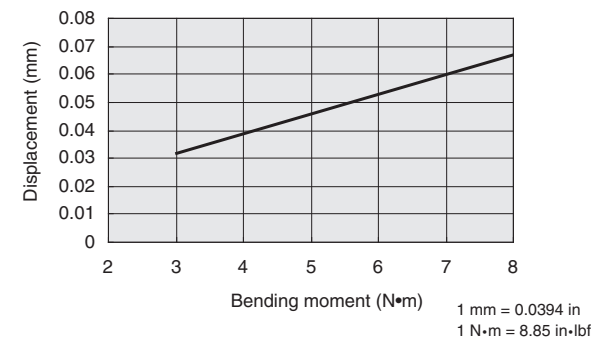

Handling Instructions and Precautions

Displacement of table due to bending moment for heat resistant specification cylinder with guide (reference values)

● Pitching (Mp)

Displacement of edge of table (arrow) when load W is applied at arrow

(Precaution: There may be a large increase in the displacement after a large impact load is applied to the table)

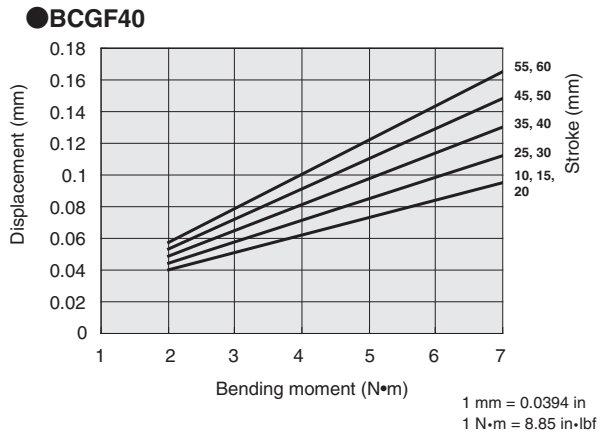
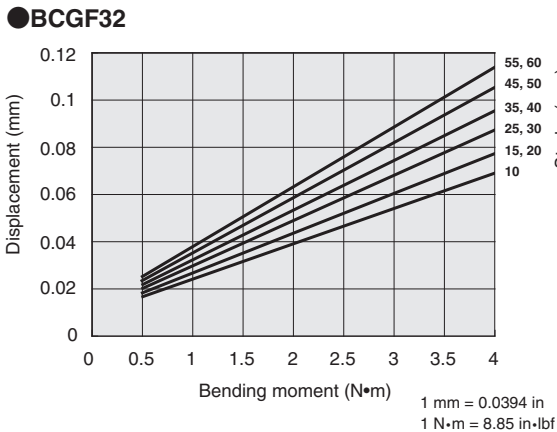
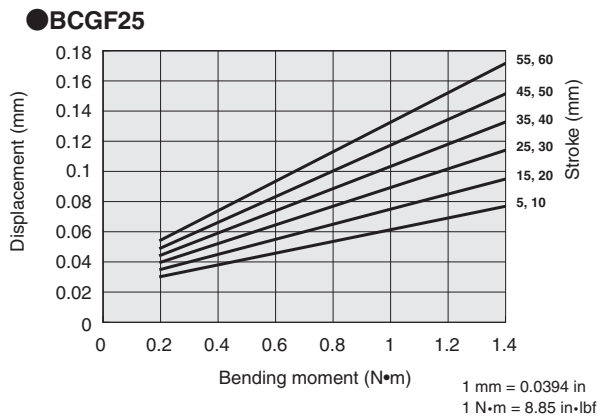
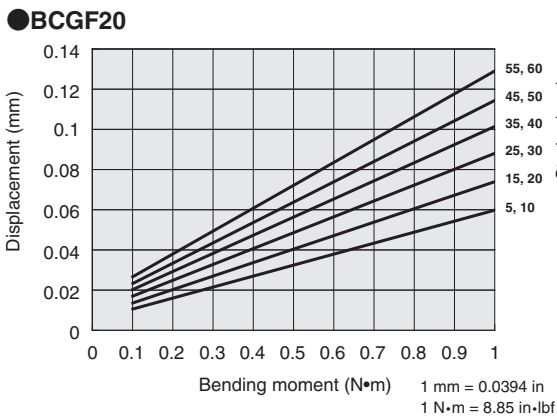
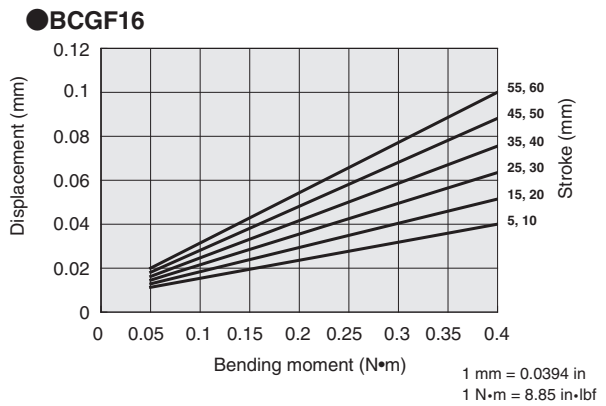
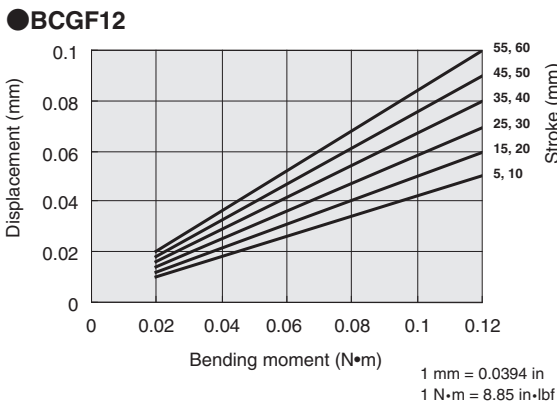
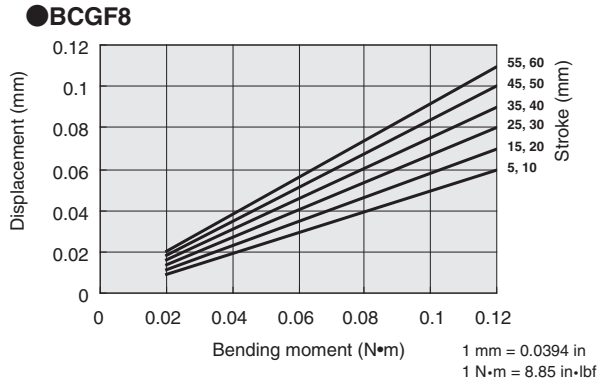
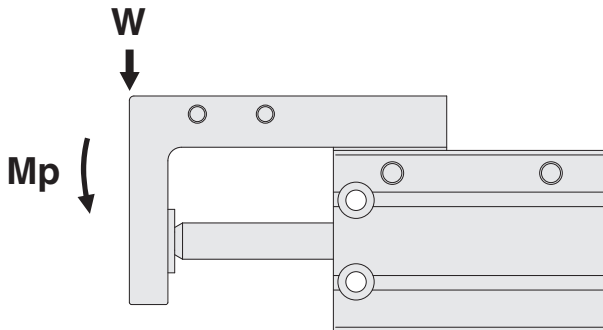

Handling Instructions and Precautions

Displacement of table due to bending moment for heat resistant specification cylinder with guide (reference values)

● Yawing (My)

Displacement of edge of table (arrow) when load W is applied at arrow

(Precaution: There may be a large increase in the displacement after a large impact load is applied to the table)

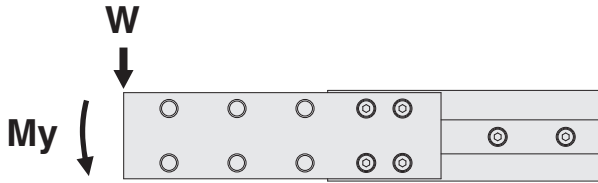

●BCGF8

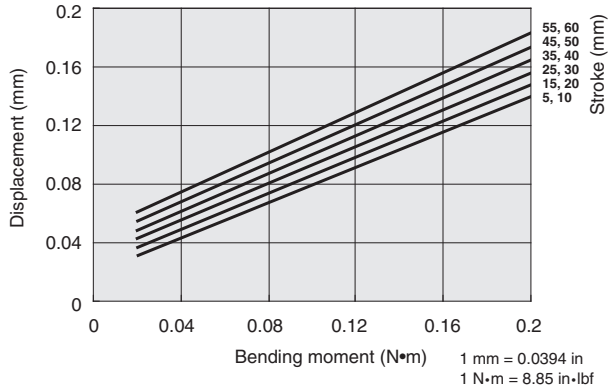

●BCGF12

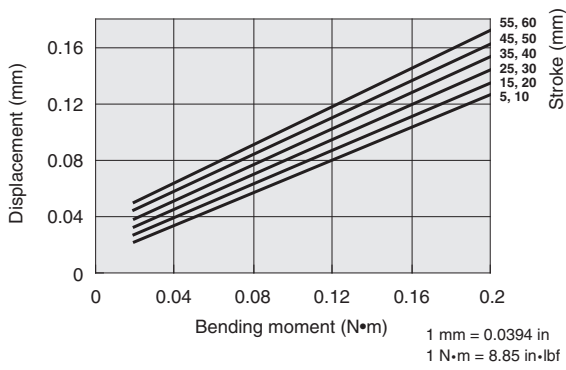

●BCGF16

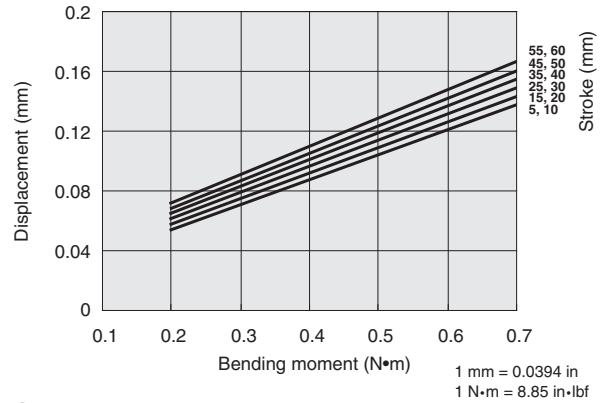

●BCGF20

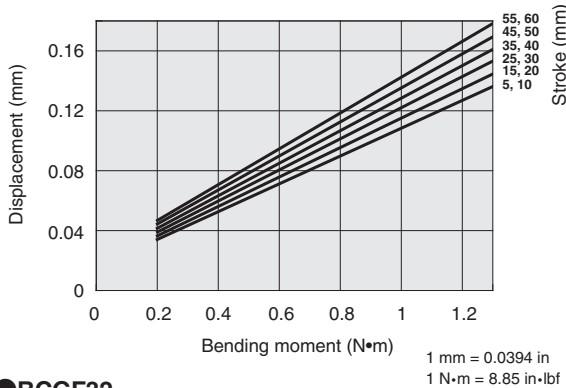

●BCGF25

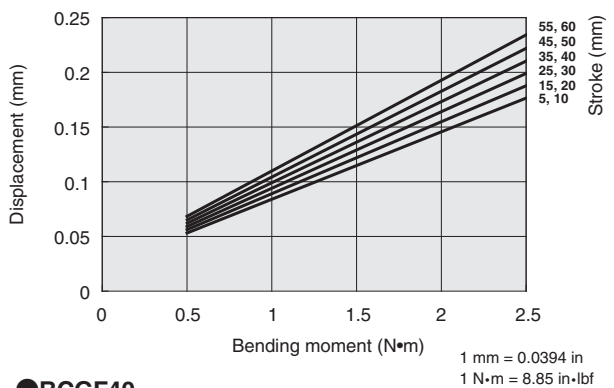

●BCGF32

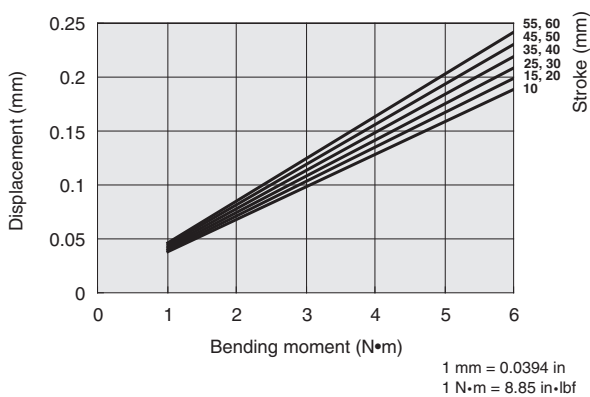

●BCGF40

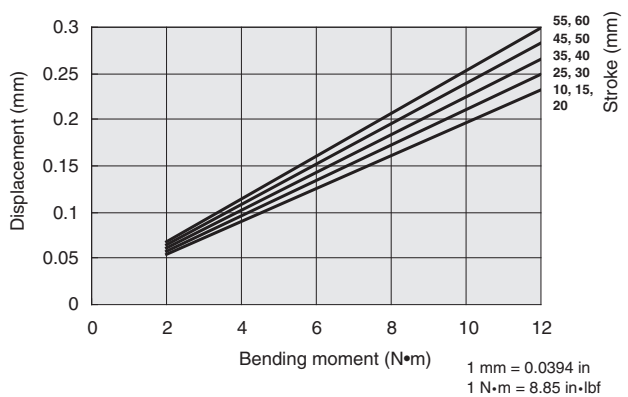

Handling Instructions and Precautions

Displacement of table due to bending moment for heat resistant specification cylinder with guide (reference values)

● Rolling (Mr)

Displacement of edge of table (arrow A) when load W is applied at arrow

(Precaution: There may be a large increase in the displacement after a large impact load is applied to the table)

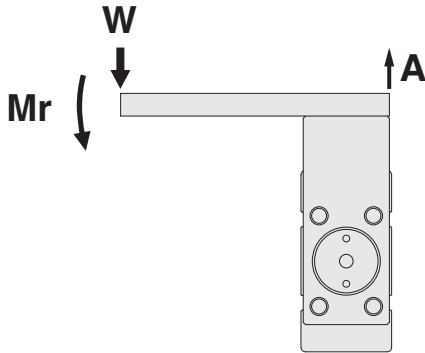

●BCGF8

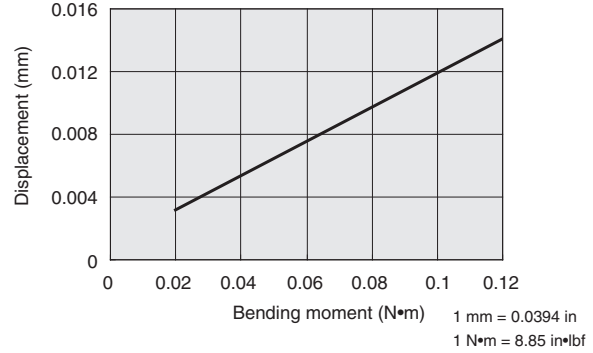

●BCGF12

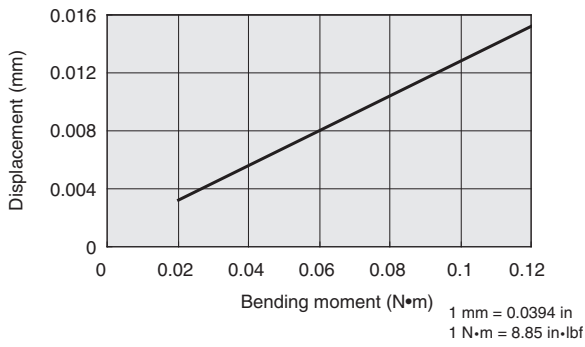

●BCGF16

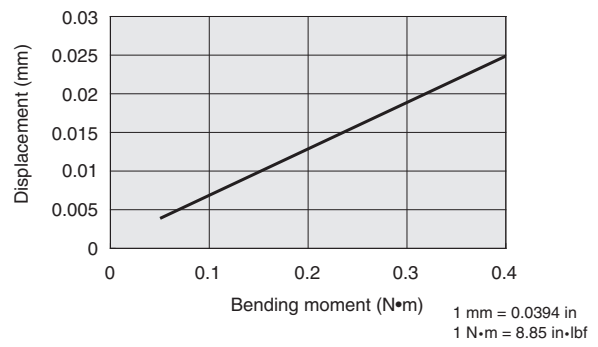

●BCGF20

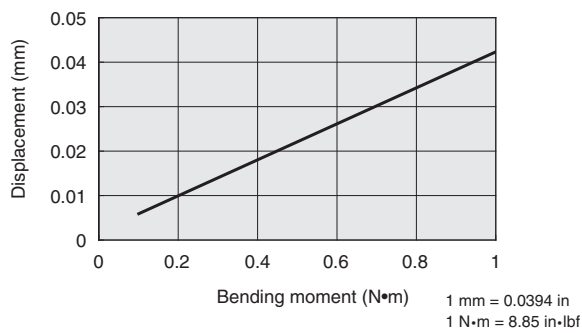

●BCGF25

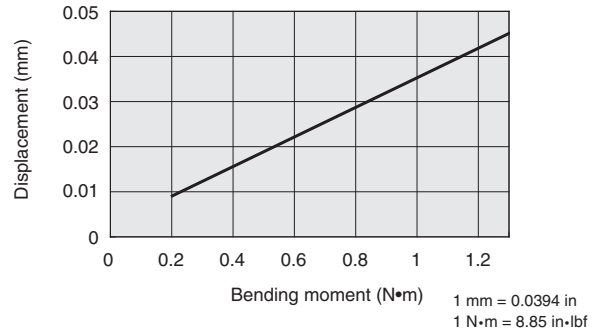

●BCGF32

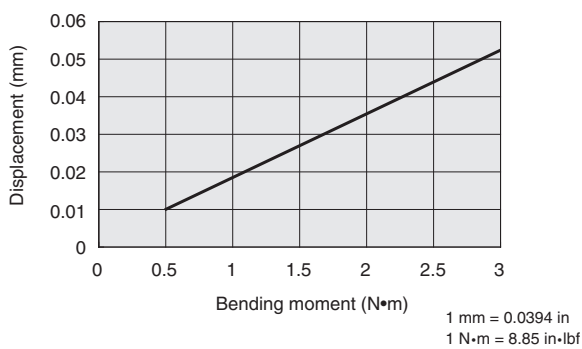

●BCGF40

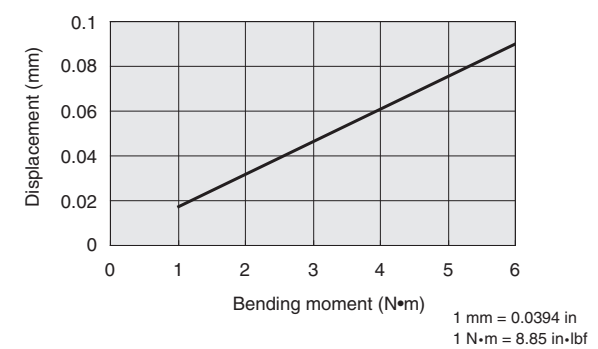

Handling Instructions and Precautions

Thrust

● Double acting type

unit: N

Cylinder bore mm	Piston rod diameter mm	Operation	Pressure area mm ²	Air pressure MPa						
				0.1	0.2	0.3	0.4	0.5	0.6	0.7
6	4	Push side	28.3	2.8	5.7	8.5	11.3	14.2	17.0	19.8
		Pull side	15.7	1.6	3.1	4.7	6.3	7.9	9.4	11.0
8	5	Push side	50.3	5.0	10.1	15.1	20.1	25.2	30.2	35.2
		Pull side	30.6	3.1	6.1	9.2	12.2	15.3	18.4	21.4
10	5	Push side	78.5	7.9	15.7	23.6	31.4	39.3	47.1	55.0
		Pull side	58.9	5.9	11.8	17.7	23.6	29.5	35.3	41.2
12	6	Push side	113.0	11.3	22.6	33.9	45.2	56.5	67.8	79.1
		Pull side	84.8	8.5	17.0	25.4	33.9	42.4	50.9	59.4
16	8	Push side	201.0	20.1	40.2	60.3	80.4	100.5	120.6	140.7
		Pull side	150.0	15.0	30.0	45.0	60.0	75.0	90.0	105.0
20	10	Push side	314.0	31.4	62.8	94.2	125.6	157.0	188.4	219.8
		Pull side	235.5	23.6	47.1	70.7	94.2	117.8	141.3	164.9
25	12	Push side	490.6	49.1	98.1	147.2	196.2	245.3	294.4	343.4
		Pull side	377.6	37.8	75.5	113.3	151.0	188.8	226.6	264.3
32	16	Push side	803.8	80.4	160.8	241.1	321.5	401.9	482.3	562.7
		Pull side	602.9	60.3	120.6	180.9	241.2	301.5	361.7	422.0
40	16	Push side	1256.0	125.6	251.2	376.8	502.4	628.0	753.6	879.2
		Pull side	1055.0	105.5	211.0	316.5	422.0	527.5	633.0	738.5
50	20	Push side	1962.5	196.3	392.5	588.8	785.0	981.3	1177.5	1373.8
		Pull side	1648.5	164.9	329.7	494.6	659.4	824.3	989.1	1154.0
63	20	Push side	3115.7	311.6	623.1	934.7	1246.3	1557.9	1869.4	2181.0
		Pull side	2801.7	280.2	560.3	840.5	1120.7	1400.9	1681.0	1961.2
80	25	Push side	5024.0	502.4	1004.8	1507.2	2009.6	2512.0	3014.4	3516.8
		Pull side	4533.4	453.3	906.7	1360.0	1813.4	2266.7	2720.0	3173.4
100	30	Push side	7850.0	785.0	1570.0	2355.0	3140.0	3925.0	4710.0	5495.0
		Pull side	7143.5	714.4	1428.7	2143.1	2857.4	3571.8	4286.1	5000.5
125	35	Push side	12265.6	1226.6	2453.1	3679.7	4906.3	6132.8	7359.4	8585.9
		Pull side	11304.0	1130.4	2260.8	3391.2	4521.6	5652.0	6782.4	7912.8

● Single acting type

unit: N

Operating type	Cylinder bore mm	Piston rod diameter mm	Pressure area mm ²	Air pressure MPa						Spring return force (at end of stroke)
				0.2	0.3	0.4	0.5	0.6	0.7	
Single acting push type	6	4	28.3	2.5	5.3	8.1	11.0	13.8	16.6	3.16
	8	5	50.3	3.6	8.6	13.6	18.7	23.7	28.7	6.5
	10	5	78.5	8.5	16.4	24.2	32.1	39.9	47.8	7.17
	12	6	113.0	12.7	24.0	35.3	46.6	57.9	69.2	9.9
	16	8	201.0	23.8	43.9	64.0	84.1	104.2	124.3	16.4
	20	10	314.0	46.4	77.8	109.2	140.6	172.0	203.4	16.4
	25	12	490.6	77.8	126.9	175.9	225.0	274.1	323.1	20.3
	32	16	803.8	127.8	208.1	288.5	368.9	449.3	529.7	33
	40	16	1256.0	211.7	337.3	462.9	588.5	714.1	839.7	39.5
Single acting pull type	6	4	15.7	—	1.3	2.8	4.4	6.0	7.5	3.45
	8	5	30.6	—	2.0	5.1	8.1	11.2	14.3	7.17
	10	5	58.9	4.6	10.5	16.4	22.3	35.3	34.2	7.17
	12	6	84.8	7.1	15.5	24.0	32.5	41.0	49.5	9.9
	16	8	150.0	13.6	28.6	43.6	58.6	73.6	88.6	16.4
	20	10	235.5	30.7	54.3	77.8	101.4	124.9	148.5	16.4
	25	12	377.6	55.2	93.0	130.7	168.5	206.3	244.0	20.3
	32	16	602.9	87.6	147.9	208.2	268.5	328.7	389.0	33
	40	16	1055.0	171.5	277.0	382.5	488.0	593.5	699.0	39.5
50	20	1648.5	276.0	440.9	605.7	770.6	935.4	1100.3	53.7	

Handling Instructions and Precautions

● Double acting type

unit: lbf

Cylinder bore in	Piston rod diameter in	Operation	Pressure area in ²	Air pressure psi						
				15	29	44	58	73	87	102
0.236	0.157	Push side	0.044	0.629	1.281	1.911	2.540	3.192	3.822	4.451
		Pull side	0.024	0.360	0.697	1.057	1.416	1.776	2.113	2.473
0.315	0.197	Push side	0.078	1.124	2.271	3.395	4.519	5.665	6.789	7.913
		Pull side	0.047	0.697	1.371	2.068	2.743	3.440	4.136	4.811
0.394	0.197	Push side	0.122	1.776	3.530	5.305	7.059	8.835	10.589	12.364
		Pull side	0.091	1.326	2.653	3.979	5.305	6.632	7.936	9.262
0.472	0.236	Push side	0.2	2.540	5.081	7.621	10.161	12.702	15.242	17.782
		Pull side	0.131	1.911	3.822	5.710	7.621	9.532	11.443	13.354
0.630	0.315	Push side	0.3	4.519	9.037	13.556	18.075	22.6	27.1	31.6
		Pull side	0.2	3.372	6.744	10.116	13.489	16.861	20.233	23.6
0.787	0.394	Push side	0.5	7.059	14.118	21.177	28.2	35.3	42.4	49.4
		Pull side	0.4	5.305	10.589	15.894	21.177	26.5	31.8	37.1
0.984	0.472	Push side	0.8	11.038	22.054	33.1	44.1	55.1	66.2	77.2
		Pull side	0.6	8.498	16.973	25.5	33.9	42.4	50.9	59.4
1.260	0.630	Push side	1.2	18.075	36.1	54.2	72.3	90.4	108.4	126.5
		Pull side	0.9	13.556	27.1	40.7	54.2	67.8	81.3	94.9
1.575	0.630	Push side	2	28.2	56.5	84.7	112.9	141.2	169.4	197.7
		Pull side	2	23.7	47.4	71.2	94.9	118.6	142.3	166.0
1.969	0.787	Push side	3	44.1	88.2	132.4	176.5	220.6	265	309
		Pull side	3	37.1	74.1	111.2	148.2	185.3	222.4	259
2.480	0.787	Push side	5	70.1	140.1	210.1	280	350	420	490
		Pull side	4	63.0	126.0	189.0	252	315	378	441
3.150	0.984	Push side	8	112.9	226	339	452	565	678	791
		Pull side	7	101.9	203.8	306	408	510	611	713
3.9	1.181	Push side	12	176.5	353	529	706	882	1059	1235
		Pull side	11	160.6	321	482	642	803	964	1124
4.9	1.378	Push side	19	276	551	827	1103	1379	1654	1930
		Pull side	18	254	508	762	1016	1271	1525	1779

● Single acting type

unit: lbf

Operating type	Cylinder bore in	Piston rod diameter in	Pressure area in ²	Air pressure psi						Spring return force (at end of stroke)
				29	44	58	73	87	102	
Single acting push type	0.236	0.157	0.044	0.562	1.191	1.821	2.473	3.102	3.732	0.710
	0.315	0.197	0.078	0.809	1.933	3.057	4.204	5.328	6.452	1.461
	0.394	0.197	0.122	1.911	3.687	5.440	7.216	8.970	10.746	1.612
	0.472	0.236	0.2	2.855	5.395	7.936	10.476	13.016	15.557	2.226
	0.630	0.315	0.3	5.350	9.869	14.388	18.906	23.4	27.9	3.687
	0.787	0.394	0.5	10.431	17.490	24.5	31.6	38.7	45.7	3.687
	0.984	0.472	0.8	17.490	28.5	39.5	50.6	61.6	72.6	4.564
	1.260	0.630	1.2	28.7	46.8	64.9	82.9	101.0	119.1	7.419
	1.575	0.630	2	47.6	75.8	104.1	132.3	160.5	188.8	8.880
Single acting pull type	0.236	0.157	0.024	—	0.292	0.629	0.989	1.349	1.686	0.776
	0.315	0.197	0.047	—	0.450	1.147	1.821	2.518	3.215	1.612
	0.394	0.197	0.091	1.034	2.360	3.687	5.013	6.340	7.668	1.612
	0.472	0.236	0.131	1.596	3.485	5.395	7.306	9.217	11.128	2.226
	0.630	0.315	0.2	3.057	6.430	9.802	13.174	16.546	19.918	3.687
	0.787	0.394	0.4	6.902	12.207	17.490	22.8	28.1	33.4	3.687
	0.984	0.472	0.6	12.409	20.907	29.4	37.9	46.4	54.9	4.564
	1.260	0.630	0.9	19.693	33.2	46.8	60.4	73.9	87.5	7.419
	1.575	0.630	2	38.6	62.3	86.0	109.7	133.4	157.1	8.880
1.969	0.787	3	62.0	99.1	136.2	173.2	210.3	247	12.072	

Basic Cylinders

Double acting type, single acting push type, single acting pull type

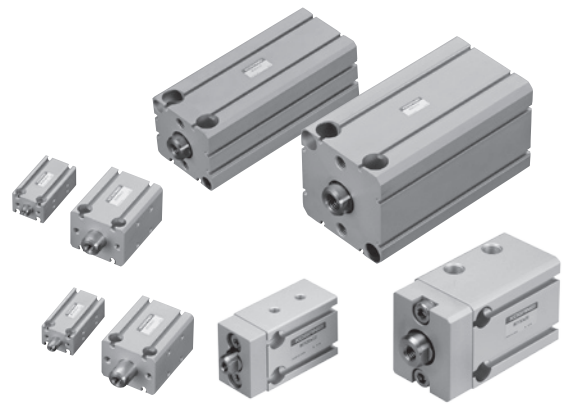

Symbol

● Double acting type

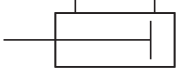

● Single acting push type

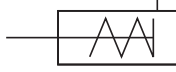

● Single acting pull type

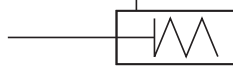

Specifications

● Double acting type (standard, corrosion resistant, heat resistant, scraper specifications ϕ 10 [0.394] to ϕ 125 [4.9])

Item	Cylinder bore	6 ^{Note1}	8 ^{Note1}	10	12	16	20	25	32	40	50	63	80	100	125	
		[0.236]	[0.315]	[0.394]	[0.472]	[0.630]	[0.787]	[0.984]	[1.260]	[1.575]	[1.969]	[2.480]	[3.150]	[3.9]	[4.9]	
Operating type		Double acting type														
Medium		Air														
Operating pressure range MPa [psi]	Standard, corrosion resistant specifications	0.12 to 0.7 [17 to 102]			0.06 to 0.7 [9 to 102]			0.05 to 0.7 [7 to 102]								
	Heat resistant specification	0.2 to 0.7 [29 to 102]			0.1 to 0.7 [15 to 102]											
	Scraper specification	—			0.1 to 0.7 [15 to 102]											
Proof pressure	MPa [psi]	1.05 [152]														
Operating temperature range	°C [°F]	0 to 60 [32 to 140] (0 to 150 [32 to 302] for heat resistant specification ^{Note 2})														
Operating speed range mm/s [in/sec]	Standard, corrosion resistant specifications	10 to 500 [0.394 to 19.7]										10 to 300 [0.394 to 11.8]				
	Heat resistant specification	100 to 300 [3.9 to 11.8]										100 to 300 [3.9 to 11.8]				
	Scraper specification	—			100 to 300 [3.9 to 11.8]											
Cushion		Rubber bumper														
Lubrication		Not required (if lubricated, use turbine oil class 1 (ISO VG32) or equivalent)														
Port size		M3×0.5			M5×0.8			Rc1/8			Rc1/4		Rc3/8			

Note 1: Scraper specification not available for cylinder bores ϕ 6 [0.236] and ϕ 8 [0.315].

2: Heat resistant specification is without sensor switch.

● Single acting type (standard, corrosion resistant specifications)

Item	Cylinder bore	6 [0.236]	8 [0.315]	10 [0.394]	12 [0.472]	16 [0.630]	20 [0.787]	25 [0.984]	32 [1.260]	40 [1.575]	50 [1.969]
		Operating type		Single acting push and pull type							
Medium		Air									
Operating pressure range MPa [psi]	Single acting push type	0.2 to 0.7 [29 to 102]			0.15 to 0.7 [22 to 102]						
	Single acting pull type	0.3 to 0.7 [44 to 102]			0.2 to 0.7 [29 to 102]			0.15 to 0.7 [22 to 102]			
Proof pressure	MPa [psi]	1.05 [152]									
Operating temperature range	°C [°F]	0 to 60 [32 to 140]									
Operating speed range	mm/s [in/sec]	50 to 500 [1.969 to 19.7]									
Cushion		Rubber bumper									
Lubrication		Not required (if lubricated, use turbine oil class 1 (ISO VG32) or equivalent)									
Port size		M3×0.5			M5×0.8			Rc1/8			

Cylinder bore and stroke

● Double acting type

Cylinder bore	Standard stroke	Maximum available stroke
6 [0.236] ^{Note1} , 8 [0.315] ^{Note1} , 10 [0.394]	5, 10, 15, 20, 25, 30	50 [1.969]
12, 16 [0.472, 0.630]	5, 10, 15, 20, 25, 30, 35, 40, 45, 50	100 [3.937]
20, 25 [0.787, 0.984]	5 ^{Note2} , 10, 15, 20, 25, 30, 35, 40, 45, 50, 55, 60, 70, 75, 80, 90, 100	125 [4.921]
32, 40 [1.260, 1.575]	10, 15, 20, 25, 30, 35, 40, 45, 50, 55, 60, 70, 75, 80, 90, 100	200 [7.874]
50, 63, 80, 100, 125 [1.969, 2.480, 3.150, 3.937, 4.921]	10, 15, 20, 25, 30, 35, 40, 45, 50, 55, 60, 70, 75, 80, 90, 100	200 [7.874]

Note 1: Scraper specification not available for cylinder bores ϕ 6 [0.236] and ϕ 8 [0.315].

2: Collar stopper is used in this stroke.

● Single acting type

Cylinder bore	Standard stroke
6, 8, 10 [0.236, 0.315, 0.394]	5, 10, 15
12, 16, 20, 25 [0.472, 0.630, 0.787, 0.984]	5, 10, 15, 20, 25, 30
32, 40, 50 [1.260, 1.575, 1.969]	10, 15, 20, 25, 30

● Standard specifications

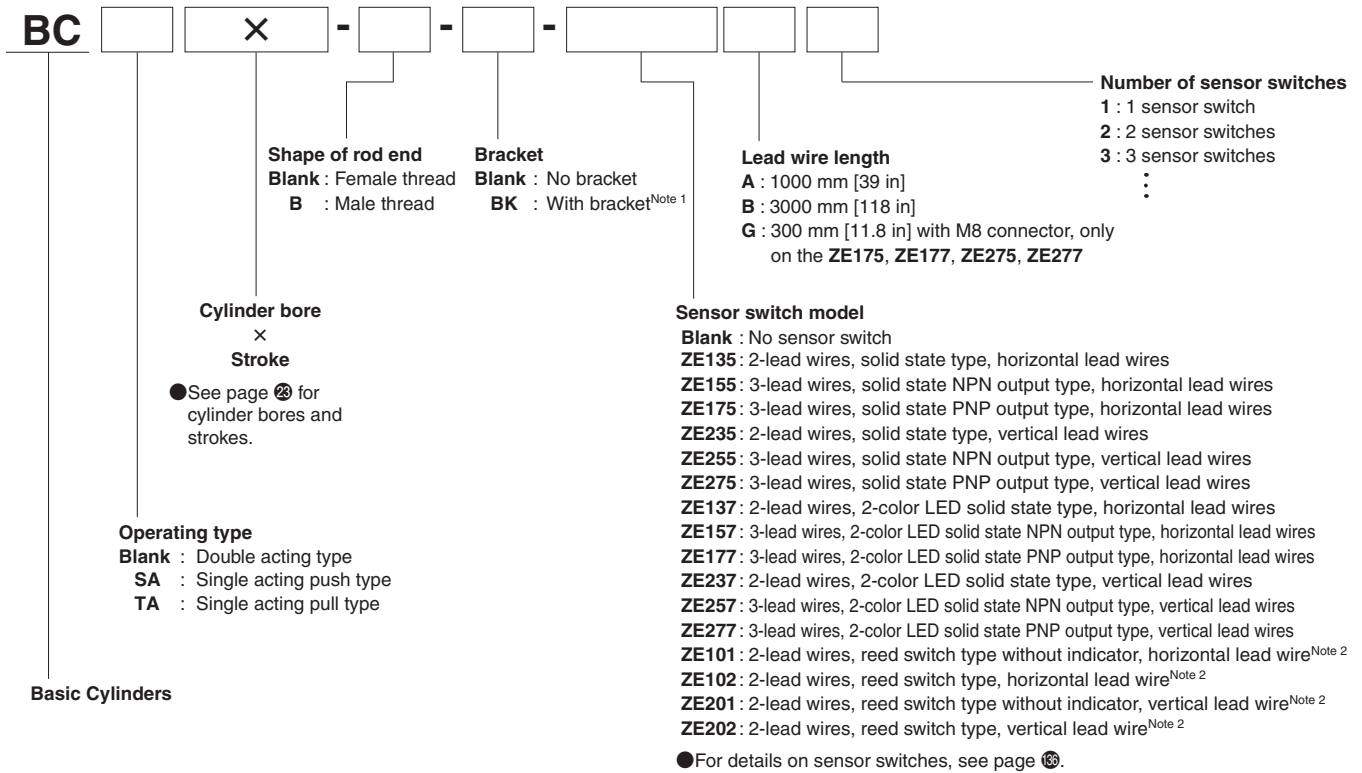

Note 1: Brackets cannot be attached to cylinders that have $\phi 6$ [0.236] and $\phi 8$ [0.315] cylinder bores.
 2: Reed type sensor switches cannot be attached to cylinders that have $\phi 6$ [0.236], $\phi 8$ [0.315], $\phi 10$ [0.394], or $\phi 12$ [0.472] cylinder bores.
 3: When using reed switch type sensor switches, operates at cylinder speed of 30 mm/s [1.181 in/sec] or higher.

● Corrosion resistant specification (Change of material of piston rod, etc.)

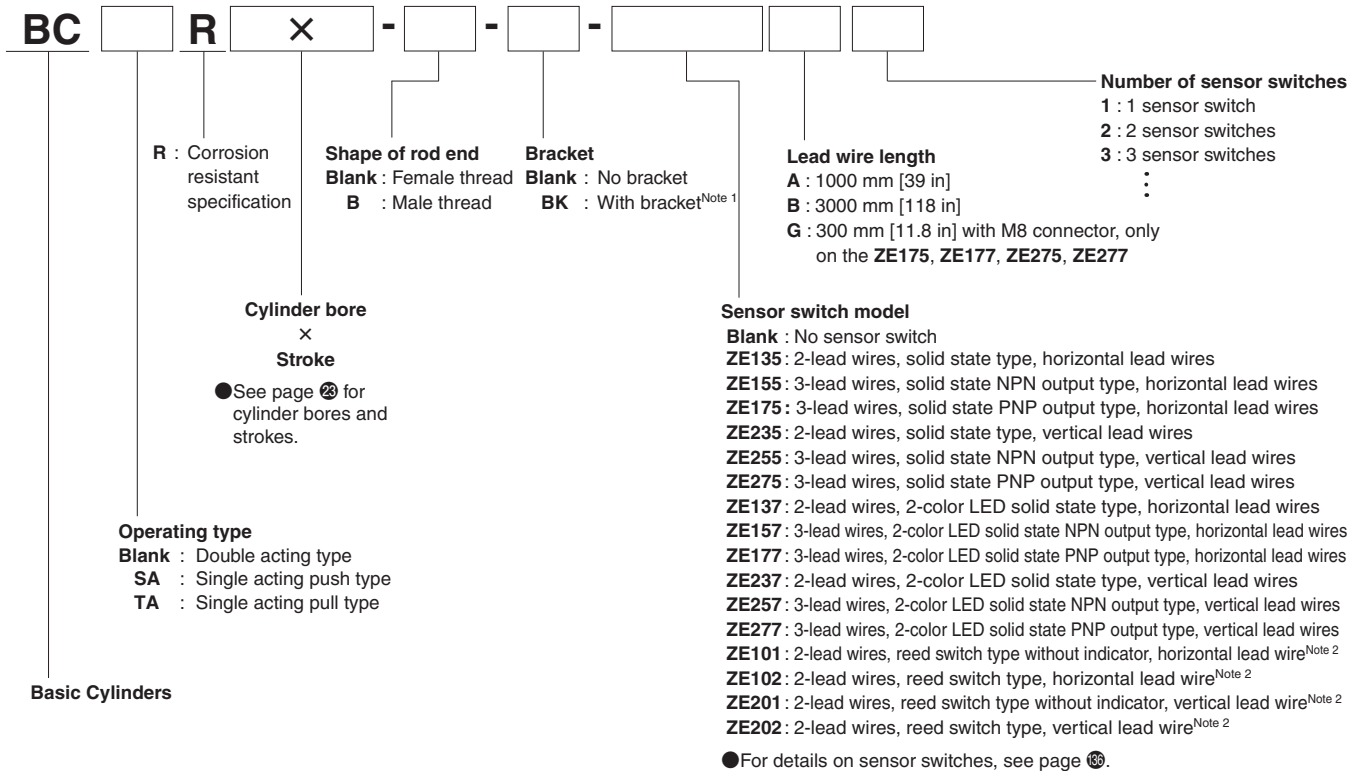

Note 1: Brackets cannot be attached to cylinders that have $\phi 6$ [0.236] and $\phi 8$ [0.315] cylinder bores.
 2: Reed type sensor switches cannot be attached to cylinders that have $\phi 6$ [0.236], $\phi 8$ [0.315], $\phi 10$ [0.394], or $\phi 12$ [0.472] cylinder bores.
 3: When using reed switch type sensor switches, operates at cylinder speed of 30 mm/s [1.181 in/sec] or higher.

Order Codes

● Heat resistant specification (Single acting type not available. Sensor switch cannot be attached.)

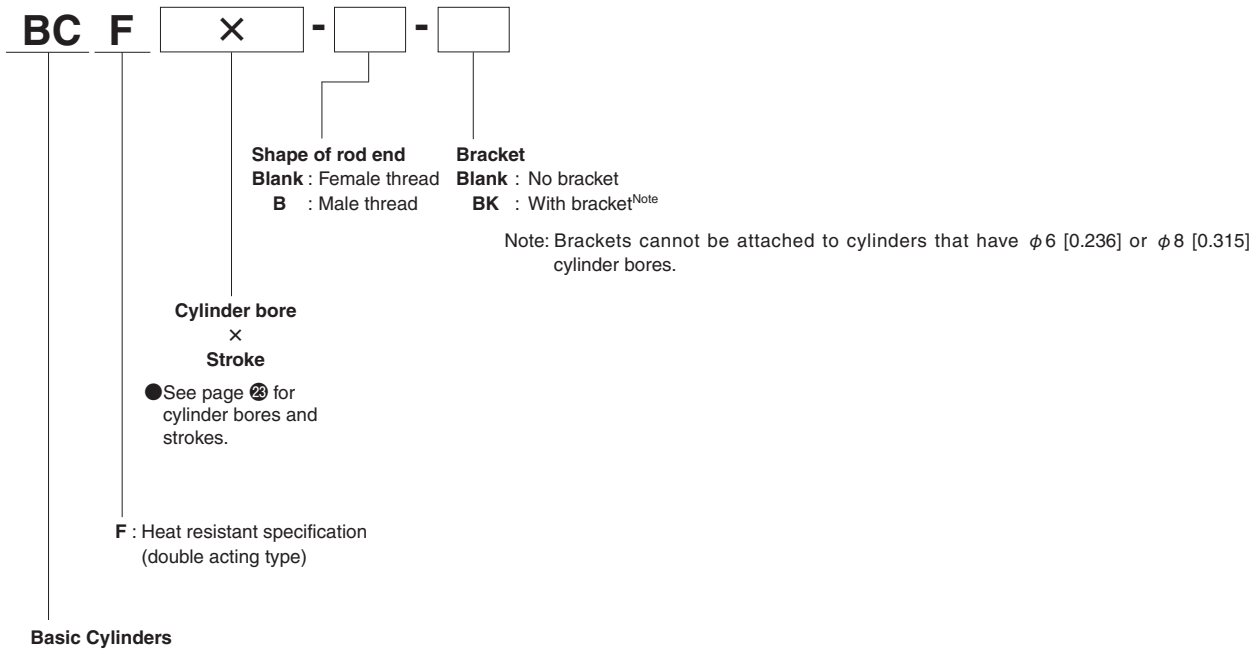

● Scraper specification (Single acting type not available. Cylinder bores $\phi 6$ [0.236] and $\phi 8$ [0.315] not available.)

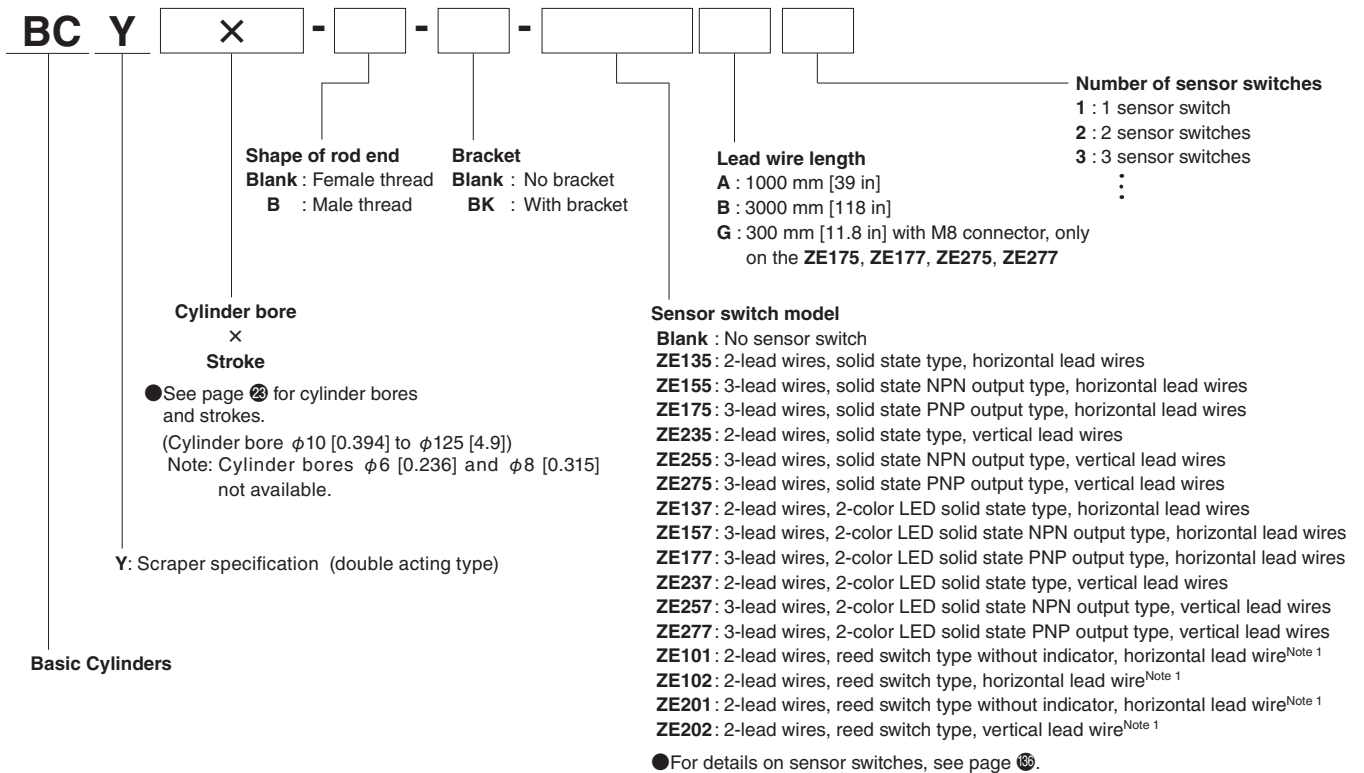

Note1: Reed type sensor switches cannot be attached to cylinders that have $\phi 10$ [0.394] and $\phi 12$ [0.472] cylinder bores.

2: When using reed switch type sensor switches, operates at cylinder speed of 30 mm/s [1.181 in/sec] or higher.

Mass

● Double acting type (standard, corrosion resistant, heat resistant specifications)

unit: g

*Model	Stroke																
	5	10	15	20	25	30	35	40	45	50	55	60	70	75	80	90	100
BC6	13 (15)	16 (18)	20 (22)	23 (25)	27 (29)	30 (32)	—	—	—	—	—	—	—	—	—	—	—
BC8	19 (21)	21 (23)	24 (26)	27 (29)	31 (32)	32 (34)	—	—	—	—	—	—	—	—	—	—	—
BC10	21 (23)	23 (25)	26 (28)	29 (31)	32 (34)	34 (36)	—	—	—	—	—	—	—	—	—	—	—
BC12	29 (32)	33 (36)	38 (41)	42 (45)	46 (49)	50 (53)	55 (58)	59 (62)	63 (66)	67 (70)	—	—	—	—	—	—	—
BC16	44 (49)	49 (54)	55 (60)	61 (66)	67 (72)	72 (77)	78 (83)	84 (89)	90 (95)	95 (100)	—	—	—	—	—	—	—
BC20	86 (96)	84 (94)	93 (103)	102 (112)	111 (121)	120 (130)	129 (139)	137 (147)	146 (156)	155 (165)	164 (174)	173 (183)	190 (200)	199 (209)	208 (218)	226 (236)	243 (253)
BC25	126 (142)	122 (138)	134 (150)	146 (162)	159 (175)	171 (187)	183 (199)	195 (211)	207 (223)	219 (235)	231 (247)	243 (259)	267 (283)	280 (296)	292 (308)	316 (332)	340 (356)
BC32	—	222 (262)	242 (282)	262 (302)	283 (323)	303 (343)	323 (363)	343 (383)	363 (403)	383 (423)	403 (443)	423 (463)	464 (504)	484 (524)	504 (544)	544 (584)	584 (624)
BC40	—	316 (356)	339 (379)	362 (402)	386 (426)	409 (449)	433 (473)	456 (496)	479 (519)	502 (542)	526 (566)	549 (589)	596 (636)	619 (659)	642 (682)	689 (729)	735 (775)
BC50	—	545 (640)	580 (675)	614 (709)	649 (744)	683 (778)	718 (813)	752 (847)	786 (881)	820 (915)	855 (950)	889 (984)	958 (1053)	993 (1088)	1027 (1122)	1096 (1191)	1164 (1259)
BC63	—	832 (927)	872 (967)	912 (1007)	952 (1047)	991 (1086)	1031 (1126)	1071 (1166)	1111 (1206)	1150 (1245)	1190 (1285)	1230 (1325)	1310 (1405)	1350 (1445)	1389 (1484)	1469 (1564)	1548 (1643)
BC80	—	1254 (1434)	1306 (1486)	1358 (1538)	1410 (1590)	1462 (1642)	1514 (1694)	1566 (1746)	1618 (1798)	1670 (1850)	1723 (1903)	1775 (1955)	1879 (2059)	1931 (2111)	1983 (2163)	2087 (2267)	2191 (2371)
BC100	—	2448 (2748)	2532 (2832)	2615 (2915)	2699 (2999)	2782 (3082)	2866 (3166)	2949 (3249)	3033 (3333)	3116 (3416)	3200 (3500)	3284 (3584)	3451 (3751)	3535 (3835)	3618 (3918)	3785 (4085)	3952 (4252)
BC125	—	4591 (5132)	4675 (5216)	4758 (5299)	4842 (5383)	4925 (5466)	5009 (5550)	5092 (5633)	5176 (5717)	5259 (5800)	5343 (5884)	5427 (5968)	5594 (6135)	5678 (6219)	5761 (6302)	5928 (6469)	6095 (6636)

Values in () parentheses are masses for male thread specifications

* The corrosion resistant specification BCR and heat resistant specification BCF have the same mass as the standard specification BC.

● Double acting type (scraper specification)

unit: g

Model	Stroke																
	5	10	15	20	25	30	35	40	45	50	55	60	70	75	80	90	100
BCY10	29 (31)	31 (33)	34 (36)	37 (39)	40 (42)	42 (44)	—	—	—	—	—	—	—	—	—	—	—
BCY12	43 (46)	47 (50)	52 (55)	56 (59)	60 (63)	64 (67)	69 (72)	73 (76)	77 (80)	81 (84)	—	—	—	—	—	—	—
BCY16	61 (66)	66 (71)	72 (77)	78 (83)	84 (89)	89 (94)	95 (100)	101 (106)	107 (112)	112 (117)	—	—	—	—	—	—	—
BCY20	111 (121)	109 (119)	118 (128)	127 (137)	136 (146)	145 (155)	154 (164)	162 (172)	171 (181)	180 (190)	189 (199)	198 (208)	215 (225)	224 (234)	233 (243)	251 (261)	268 (278)
BCY25	162 (178)	158 (174)	170 (186)	182 (198)	195 (211)	207 (223)	219 (235)	231 (247)	243 (259)	255 (271)	267 (283)	279 (295)	303 (319)	316 (332)	328 (344)	352 (368)	376 (392)
BCY32	—	306 (346)	326 (366)	346 (386)	367 (407)	387 (427)	407 (447)	427 (467)	447 (487)	467 (507)	487 (527)	507 (547)	548 (588)	568 (608)	588 (628)	628 (668)	668 (708)
BCY40	—	437 (477)	460 (500)	483 (523)	507 (547)	530 (570)	554 (594)	577 (617)	600 (640)	623 (663)	647 (687)	670 (710)	717 (757)	740 (780)	763 (803)	810 (850)	856 (896)
BCY50	—	740 (835)	775 (870)	809 (904)	844 (939)	878 (973)	913 (1008)	947 (1042)	981 (1076)	1015 (1110)	1050 (1145)	1084 (1179)	1153 (1248)	1188 (1283)	1222 (1317)	1291 (1386)	1359 (1454)
BCY63	—	1174 (1269)	1214 (1309)	1254 (1349)	1294 (1389)	1333 (1428)	1373 (1468)	1413 (1508)	1453 (1548)	1492 (1587)	1532 (1627)	1572 (1667)	1652 (1747)	1692 (1787)	1731 (1826)	1811 (1906)	1890 (1985)
BCY80	—	1724 (1904)	1776 (2246)	1828 (2008)	1880 (2060)	1932 (2112)	1984 (2164)	2036 (2216)	2088 (2268)	2140 (2320)	2193 (2373)	2245 (2425)	2349 (2529)	2401 (2581)	2453 (2633)	2557 (2737)	2661 (2841)
BCY100	—	3552 (3852)	3636 (4136)	3719 (4219)	3803 (4303)	3886 (4386)	3970 (4470)	4053 (4553)	4137 (4637)	4220 (4520)	4304 (4804)	4388 (4888)	4555 (5055)	4639 (5139)	4722 (5222)	4889 (5389)	5056 (5556)
BCY125	—	5272 (5813)	5356 (5897)	5439 (5980)	5523 (6064)	5606 (6147)	5690 (6231)	5773 (6314)	5857 (6398)	5940 (6481)	6024 (6565)	6108 (6649)	6275 (6816)	6359 (6900)	6442 (6983)	6609 (7150)	6776 (7317)

Values in () parentheses are masses for male thread specifications

● Single acting push type (standard, corrosion resistant specifications) unit: g

*Model	Stroke					
	5	10	15	20	25	30
BCSA6	22 (24)	25 (27)	28 (30)	—	—	—
BCSA8	30 (32)	33 (35)	36 (38)	—	—	—
BCSA10	34 (36)	37 (39)	40 (42)	—	—	—
BCSA12	49 (52)	53 (56)	57 (60)	61 (64)	65 (68)	69 (72)
BCSA16	73 (78)	79 (84)	85 (90)	91 (96)	97 (102)	103 (108)
BCSA20	110 (120)	119 (129)	128 (138)	137 (147)	146 (156)	155 (165)
BCSA25	160 (176)	173 (189)	186 (202)	199 (215)	212 (228)	225 (241)
BCSA32	—	289 (329)	318 (358)	347 (387)	376 (416)	405 (445)
BCSA40	—	426 (466)	458 (498)	490 (530)	522 (562)	554 (594)
BCSA50	—	750 (845)	786 (881)	822 (917)	858 (953)	894 (989)

Values in () parentheses are masses for male thread specifications

* The corrosion resistant specification BCSAR has the same mass as the standard specification BCSA.

● Single acting pull type (standard, corrosion resistant specifications) unit: g

*Model	Stroke					
	5	10	15	20	25	30
BCTA6	20 (22)	23 (25)	26 (28)	—	—	—
BCTA8	26 (28)	29 (31)	32 (34)	—	—	—
BCTA10	29 (31)	32 (34)	35 (37)	—	—	—
BCTA12	43 (46)	47 (50)	51 (54)	55 (58)	59 (62)	63 (66)
BCTA16	63 (68)	69 (74)	75 (80)	81 (86)	87 (92)	93 (98)
BCTA20	98 (108)	107 (117)	116 (126)	125 (135)	134 (144)	143 (153)
BCTA25	144 (160)	157 (173)	170 (186)	183 (199)	196 (212)	209 (225)
BCTA32	—	260 (300)	281 (321)	302 (342)	323 (363)	344 (384)
BCTA40	—	404 (444)	428 (468)	452 (492)	476 (516)	500 (540)
BCTA50	—	720 (815)	756 (851)	792 (887)	828 (923)	864 (959)

Values in () parentheses are masses for male thread specifications

* The corrosion resistant specification BCTAR has the same mass as the standard specification BCTA.

● Additional mass of sensor switches

ZE□□□A, ZE□□□G: 15 g ZE□□□B: 35 g

Mass

● Double acting type (standard, corrosion resistant, heat resistant specifications)

unit: oz

*Model	Stroke mm [in]																
	5 [0.197]	10 [0.394]	15 [0.591]	20 [0.787]	25 [0.984]	30 [1.181]	35 [1.378]	40 [1.575]	45 [1.772]	50 [1.969]	55 [2.165]	60 [2.362]	70 [2.756]	75 [2.953]	80 [3.150]	90 [3.543]	100 [3.9]
BC6	0.459 (0.529)	0.564 (0.635)	0.705 (0.776)	0.811 (0.882)	0.952 (1.023)	1.058 (1.129)	—	—	—	—	—	—	—	—	—	—	—
BC8	0.670 (0.741)	0.741 (0.811)	0.847 (0.917)	0.952 (1.023)	1.093 (1.129)	1.129 (1.199)	—	—	—	—	—	—	—	—	—	—	—
BC10	0.741 (0.811)	0.811 (0.882)	0.917 (0.988)	1.023 (1.093)	1.129 (1.199)	1.199 (1.270)	—	—	—	—	—	—	—	—	—	—	—
BC12	1.023 (1.129)	1.164 (1.270)	1.34 (1.446)	1.482 (1.587)	1.623 (1.728)	1.764 (1.870)	1.940 (2.046)	2.081 (2.187)	2.222 (2.328)	2.363 (2.469)	—	—	—	—	—	—	—
BC16	1.552 (1.728)	1.728 (1.905)	1.94 (2.116)	2.152 (2.328)	2.363 (2.540)	2.540 (2.716)	2.751 (2.928)	2.963 (3.139)	3.175 (3.351)	3.351 (3.5)	—	—	—	—	—	—	—
BC20	3.034 (3.386)	2.963 (3.316)	3.28 (3.6)	3.6 (4.0)	3.9 (4.3)	4.2 (4.6)	4.6 (4.9)	4.8 (5.2)	5.1 (5.5)	5.5 (5.8)	5.8 (6.1)	6.1 (6.5)	6.7 (7.1)	7.0 (7.4)	7.3 (7.7)	8.0 (8.3)	8.6 (8.9)
BC25	4.4 (5.0)	4.3 (4.9)	4.7 (5.3)	5.1 (5.7)	5.6 (6.2)	6.0 (6.6)	6.5 (7.0)	6.9 (7.4)	7.3 (7.9)	7.7 (8.3)	8.1 (8.7)	8.6 (9.1)	9.4 (10.0)	9.9 (10.4)	10.3 (10.9)	11.1 (11.7)	12.0 (12.6)
BC32	—	7.8 (9.2)	8.5 (9.9)	9.2 (10.7)	10 (11.4)	10.7 (12.1)	11.4 (12.8)	12.1 (13.5)	12.8 (14.2)	13.5 (14.9)	14.2 (15.6)	14.9 (16.3)	16.4 (17.8)	17.1 (18.5)	17.8 (19.2)	19.2 (20.6)	20.6 (22.0)
BC40	—	11.1 (12.6)	12 (13.4)	12.8 (14.2)	13.6 (15.0)	14.4 (15.8)	15.3 (16.7)	16.1 (17.5)	16.9 (18.3)	17.7 (19.1)	18.6 (20.0)	19.4 (20.8)	21.0 (22.4)	21.8 (23.2)	22.6 (24.1)	24.3 (25.7)	25.9 (27.3)
BC50	—	19.2 (22.6)	20.5 (23.8)	21.7 (25.0)	22.9 (26.2)	24.1 (27.4)	25.3 (28.7)	26.5 (29.9)	27.7 (31.1)	28.9 (32.3)	30.2 (33.5)	31.4 (34.7)	33.8 (37.4)	35.0 (38)	36 (40)	39 (42)	41 (44)
BC63	—	29.3 (32.7)	30.8 (34.1)	32.2 (36)	33.6 (37)	35 (38)	36 (40)	38 (41)	39 (43)	41 (44)	42 (45)	43 (47)	46 (50)	48 (51)	49 (52)	52 (55)	55 (58)
BC80	—	44 (51)	46 (52)	48 (54)	50 (56)	52 (58)	53 (60)	55 (62)	57 (63)	59 (65)	61 (67)	63 (69)	66 (73)	68 (74)	70 (76)	74 (80)	77 (84)
BC100	—	86 (97)	89 (100)	92 (103)	95 (106)	98 (109)	101 (112)	104 (115)	107 (118)	110 (120)	113 (123)	116 (126)	122 (132)	125 (135)	128 (138)	134 (144)	139 (150)
BC125	—	162 (181)	165 (184)	168 (187)	171 (190)	174 (193)	177 (196)	180 (199)	183 (202)	186 (205)	188 (208)	191 (211)	197 (216)	200 (219)	203 (222)	209 (228)	215 (234)

Values in () parentheses are masses for male thread specifications

* The corrosion resistant specification BCR and heat resistant specification BCF have the same mass as the standard specification BC.

● Double acting type (scraper specification)

unit: oz

Model	Stroke mm [in]																
	5 [0.197]	10 [0.394]	15 [0.591]	20 [0.787]	25 [0.984]	30 [1.181]	35 [1.378]	40 [1.575]	45 [1.772]	50 [1.969]	55 [2.165]	60 [2.362]	70 [2.756]	75 [2.953]	80 [3.150]	90 [3.543]	100 [3.9]
BCY10	1.023 (1.093)	1.093 (1.164)	1.199 (1.270)	1.305 (1.376)	1.411 (1.482)	1.482 (1.552)	—	—	—	—	—	—	—	—	—	—	—
BCY12	1.517 (1.623)	1.658 (1.764)	1.834 (1.940)	1.975 (2.081)	2.116 (2.222)	2.258 (2.363)	2.434 (2.540)	2.575 (2.681)	2.716 (2.822)	2.857 (2.963)	—	—	—	—	—	—	—
BCY16	2.152 (2.328)	2.328 (2.504)	2.54 (2.716)	2.751 (2.928)	2.963 (3.139)	3.139 (3.316)	3.351 (3.5)	3.6 (3.7)	3.8 (4.0)	4.0 (4.1)	—	—	—	—	—	—	—
BCY20	3.9 (4.3)	3.8 (4.2)	4.2 (4.5)	4.5 (4.8)	4.8 (5.1)	5.1 (5.5)	5.4 (5.8)	5.7 (6.1)	6.0 (6.4)	6.3 (6.7)	6.7 (7.0)	7.0 (7.3)	7.6 (7.9)	7.9 (8.3)	8.2 (8.6)	8.9 (9.2)	9.5 (9.8)
BCY25	5.7 (6.3)	5.6 (6.1)	6.0 (6.6)	6.4 (7.0)	6.9 (7.4)	7.3 (7.9)	7.7 (8.3)	8.1 (8.7)	8.6 (9.1)	9.0 (9.6)	9.4 (10.0)	9.8 (10.4)	10.7 (11.3)	11.1 (11.7)	11.6 (12.1)	12.4 (13.0)	13.3 (13.8)
BCY32	—	10.8 (12.2)	11.5 (12.9)	12.2 (13.6)	12.9 (14.4)	13.7 (15.1)	14.4 (15.8)	15.1 (16.5)	15.8 (17.2)	16.5 (17.9)	17.2 (18.6)	17.9 (19.3)	19.3 (20.7)	20.0 (21.4)	20.7 (22.2)	22.2 (23.6)	23.6 (25.0)
BCY40	—	15.4 (16.8)	16.2 (17.6)	17.0 (18.4)	17.9 (19.3)	18.7 (20.1)	19.5 (21.0)	20.4 (21.8)	21.2 (22.6)	22.0 (23.4)	22.8 (24.2)	23.6 (25.0)	25.3 (26.7)	26.1 (27.5)	26.9 (28.3)	28.6 (30.0)	30.2 (31.6)
BCY50	—	26.1 (29.5)	27.3 (30.7)	28.5 (31.9)	29.8 (33.1)	31 (34.3)	32.2 (36)	33.4 (37)	34.6 (38)	36 (39)	37 (40)	38 (42)	41 (44)	42 (45)	43 (46)	46 (49)	48 (51)
BCY63	—	41 (45)	43 (46)	44 (48)	46 (49)	47 (50)	48 (52)	50 (53)	51 (55)	53 (56)	54 (57)	55 (59)	58 (62)	60 (63)	61 (64)	64 (67)	67 (70)
BCY80	—	61 (67)	63 (79)	64 (71)	66 (73)	68 (74)	70 (76)	72 (78)	74 (80)	75 (82)	77 (84)	79 (86)	83 (89)	85 (91)	87 (93)	90 (97)	94 (100)
BCY100	—	125 (136)	128 (146)	131 (149)	134 (152)	137 (155)	140 (158)	143 (161)	146 (164)	149 (159)	152 (169)	155 (172)	161 (178)	164 (181)	167 (184)	172 (190)	178 (196)
BCY125	—	186 (205)	189 (208)	192 (211)	195 (214)	198 (217)	201 (220)	204 (223)	207 (226)	210 (229)	212 (232)	215 (235)	221 (240)	224 (243)	227 (246)	233 (252)	239 (258)

Values in () parentheses are masses for male thread specifications

● Single acting push type (standard, corrosion resistant specifications) unit: oz

*Model	Stroke mm [in]					
	5 [0.197]	10 [0.394]	15 [0.591]	20 [0.787]	25 [0.984]	30 [1.181]
BCSA6	0.776 (0.847)	0.882 (0.952)	0.988 (1.058)	—	—	—
BCSA8	1.058 (1.129)	1.164 (1.235)	1.270 (1.340)	—	—	—
BCSA10	1.199 (1.270)	1.305 (1.376)	1.411 (1.482)	—	—	—
BCSA12	1.728 (1.834)	1.870 (1.975)	2.011 (2.116)	2.152 (2.258)	2.293 (2.399)	2.434 (2.540)
BCSA16	2.575 (2.751)	2.787 (2.963)	2.998 (3.175)	3.210 (3.386)	3.422 (3.6)	3.6 (3.8)
BCSA20	3.9 (4.2)	4.2 (4.6)	4.5 (4.9)	4.8 (5.2)	5.1 (5.5)	5.5 (5.8)
BCSA25	5.6 (6.2)	6.1 (6.7)	6.6 (7.1)	7.0 (7.6)	7.5 (8.0)	7.9 (8.5)
BCSA32	—	10.2 (11.6)	11.2 (12.6)	12.2 (13.7)	13.3 (14.7)	14.3 (15.7)
BCSA40	—	15.0 (16.4)	16.2 (17.6)	17.3 (18.7)	18.4 (19.8)	19.5 (21.0)
BCSA50	—	26.5 (29.8)	27.7 (31.1)	29.0 (32.3)	30.3 (33.6)	31.5 (34.9)

Values in () parentheses are masses for male thread specifications

* The corrosion resistant specification BCSAR has the same mass as the standard specification BCSA.

● Single acting pull type (standard, corrosion resistant specifications) unit: oz

*Model	Stroke mm [in]					
	5 [0.197]	10 [0.394]	15 [0.591]	20 [0.787]	25 [0.984]	30 [1.181]
BCTA6	0.705 (0.776)	0.811 (0.882)	0.917 (0.988)	—	—	—
BCTA8	0.917 (0.988)	1.023 (1.093)	1.129 (1.199)	—	—	—
BCTA10	1.023 (1.093)	1.129 (1.199)	1.235 (1.305)	—	—	—
BCTA12	1.517 (1.623)	1.658 (1.764)	1.799 (1.905)	1.940 (2.046)	2.081 (2.187)	2.222 (2.328)
BCTA16	2.222 (2.399)	2.434 (2.610)	2.646 (2.822)	2.857 (3.034)	3.069 (3.245)	3.280 (3.457)
BCTA20	3.457 (3.8)	3.8 (4.1)	4.1 (4.4)	4.4 (4.8)	4.7 (5.1)	5.0 (5.4)
BCTA25	5.1 (5.6)	5.5 (6.1)	6.0 (6.6)	6.5 (7.0)	6.9 (7.5)	7.4 (7.9)
BCTA32	—	9.2 (10.6)	9.9 (11.3)	10.7 (12.1)	11.4 (12.8)	12.1 (13.5)
BCTA40	—	14.3 (15.7)	15.1 (16.5)	15.9 (17.4)	16.8 (18.2)	17.6 (19.0)
BCTA50	—	25.4 (28.7)	26.7 (30.0)	27.9 (31.3)	29.2 (32.6)	30.5 (33.8)

Values in () parentheses are masses for male thread specifications

* The corrosion resistant specification BCTAR has the same mass as the standard specification BCTA.

● Additional mass of sensor switches

ZE□□□A, ZE□□□G: 0.529 oz ZE□□□B: 1.235 oz

Inner construction

■ Double acting type (standard, corrosion resistant, heat resistant specifications) * For scraper specification structure diagrams, refer to page 80.

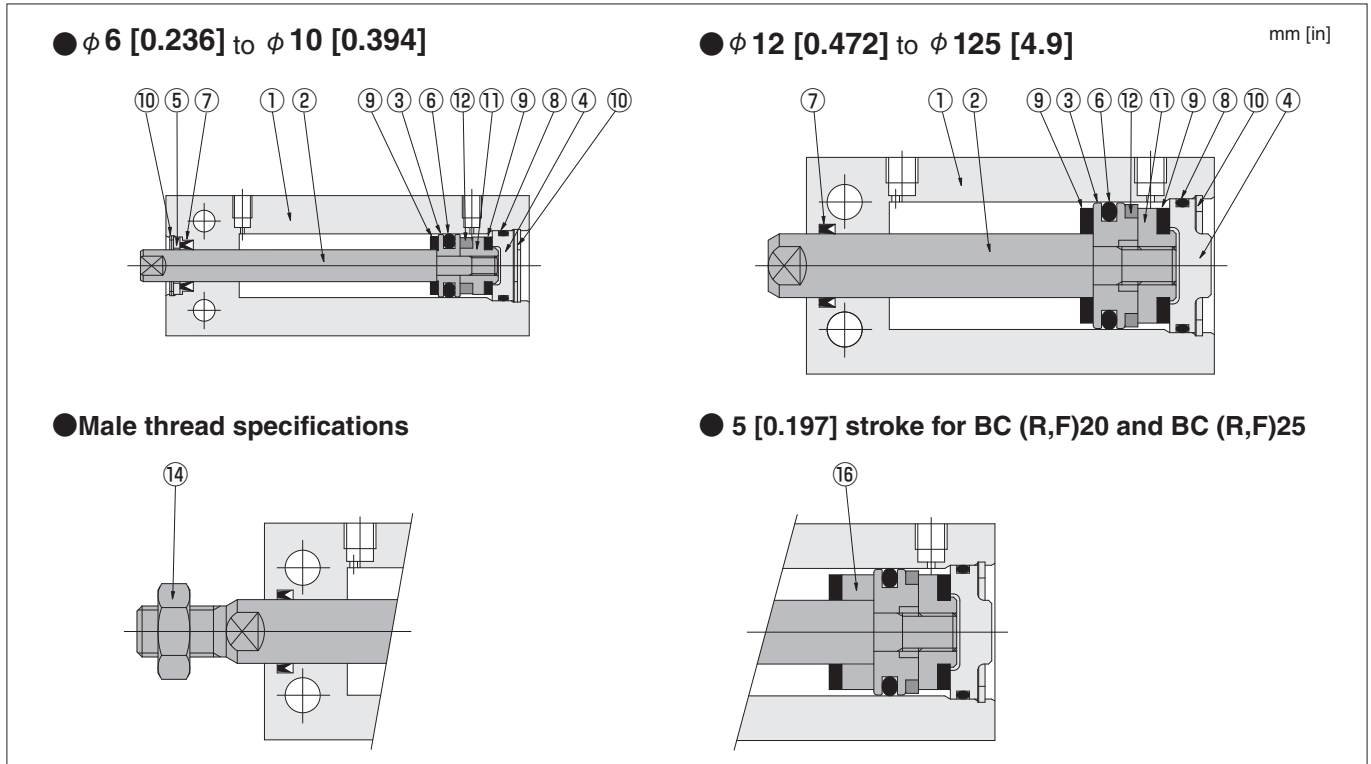

■ Single acting push type (standard, corrosion resistant specifications)

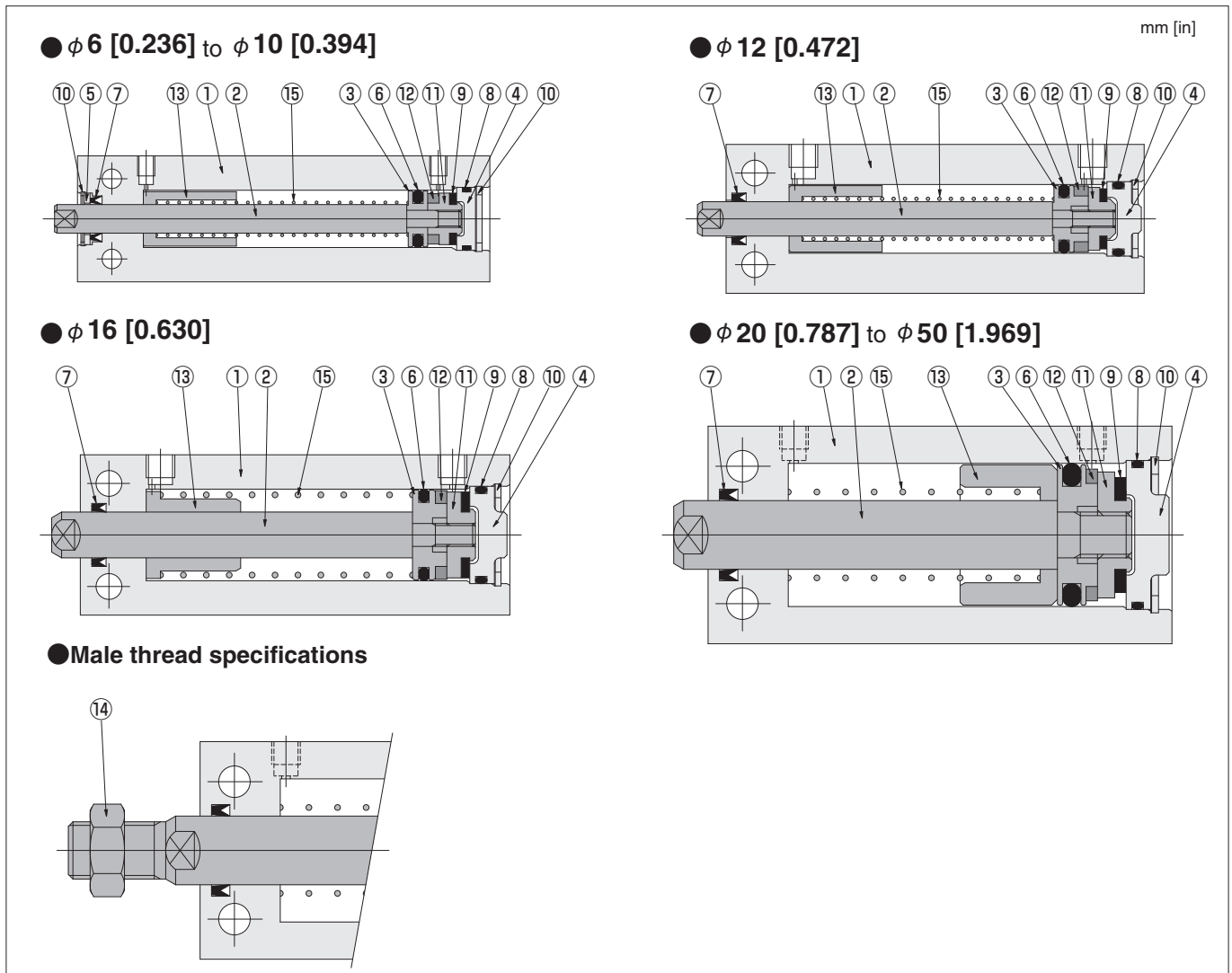

Single acting pull type (standard, corrosion resistant specifications)

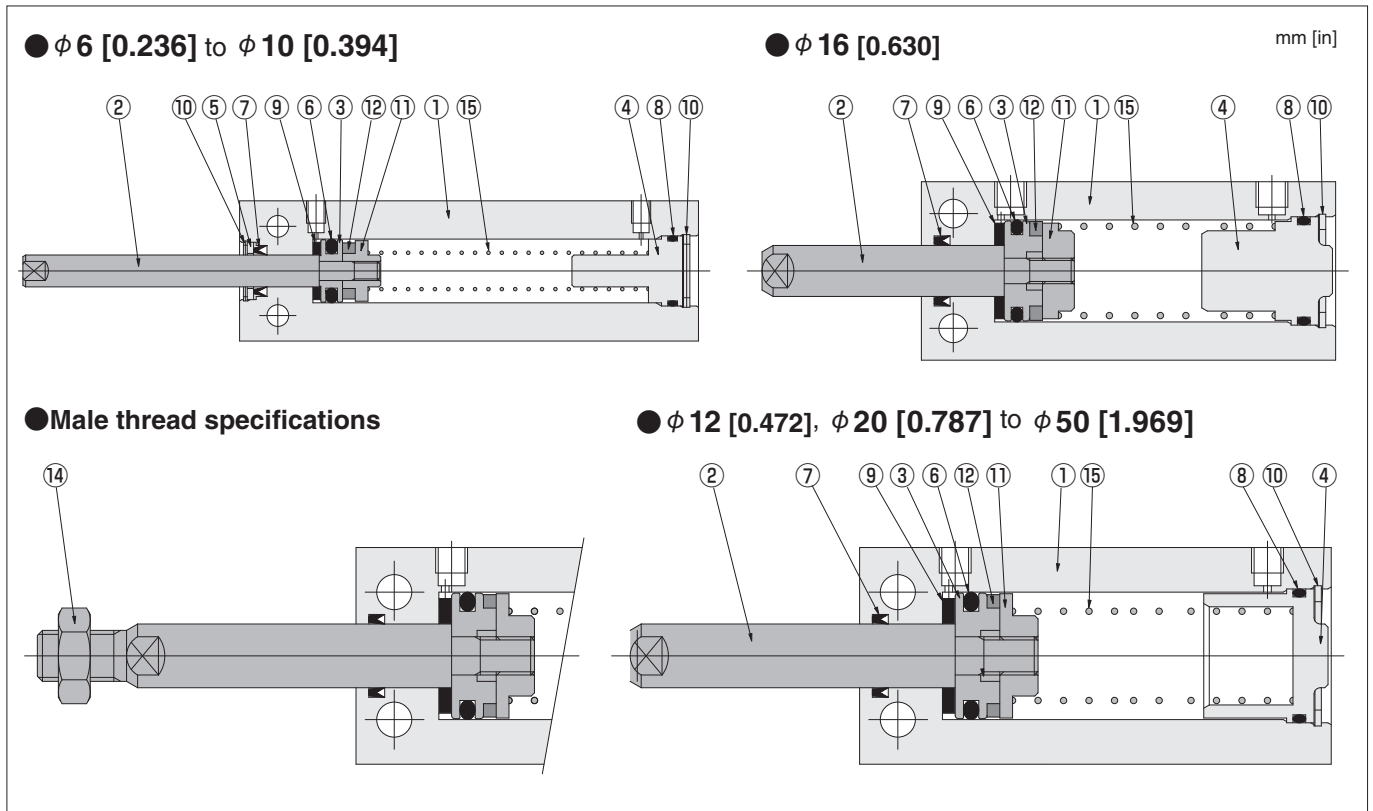

Major parts and materials (standard, corrosion resistant, heat resistant specifications)

No.	Name	φ 6 [0.236]	φ 8 [0.315]	φ 10 [0.394]	φ 12 [0.472]	φ 16 [0.630]	φ 20 [0.787]	φ 25 [0.984]	φ 32 [1.260]	φ 40 [1.575]	φ 50 [1.969]	φ 63 [2.480]	φ 80 [3.150]	φ 100 [3.9]	φ 125 [4.9]	
①	Cylinder body	Aluminum alloy (special anti-abrasion treated)														
②	Piston rod	Stainless steel							Carbon steel (Corrosion and heat resistant specifications are stainless steel.)							
③	Piston	Stainless steel					Aluminum alloy (anodized)									
④	Head cover	Aluminum alloy (anodized)														
⑤	Seal holder	Aluminum alloy (anodized)	—	—	—	—	—	—	—	—	—	—	—	—	—	
⑥	★Piston seal	Synthetic rubber (NBR) (heat resistant specification: FKM)														
⑦	★Rod seal	Synthetic rubber (NBR) (heat resistant specification: FKM)														
⑧	★O-ring	Synthetic rubber (NBR) (heat resistant specification: FKM)														
⑨	Bumper	Urethane rubber	Synthetic rubber (NBR) (heat resistant specification: FKM)													
⑩	★Retaining ring	Stainless steel ^{Note 1}			Steel (Corrosion and heat resistant specifications are electroless nickel plated.)											
⑪	Support	Stainless steel	Aluminum alloy (anodized) ^{Note 2}													
⑫	Magnet	Neodymium magnet (no heat resistant specification)							Plastic magnet (no heat resistant specification)							
⑬	Spring support	Stainless steel					Aluminum alloy (anodized)					—	—	—	—	
⑭	Rod end nut	Carbon steel (Corrosion and heat resistant specifications are stainless steel.)														
⑮	★Spring	Piano wire														
⑯	Stopper ^{Note 3}	—	—	—	—	—	Aluminum alloy (anodized)	—	—	—	—	—	—	—	—	

Items indicated by a ★ are available as additional parts or in packing sets. For order codes, see page 13 and 15.

Note 1: φ 6 [0.236] head cover side is steel. (Corrosion and heat resistant specifications are electroless nickel plated.)

2: φ 8 [0.315] and φ 10 [0.394] single acting pull types are stainless steel.

3: Only stroke 5 [0.197] has a collar stopper.

Double acting type (scraper specification)

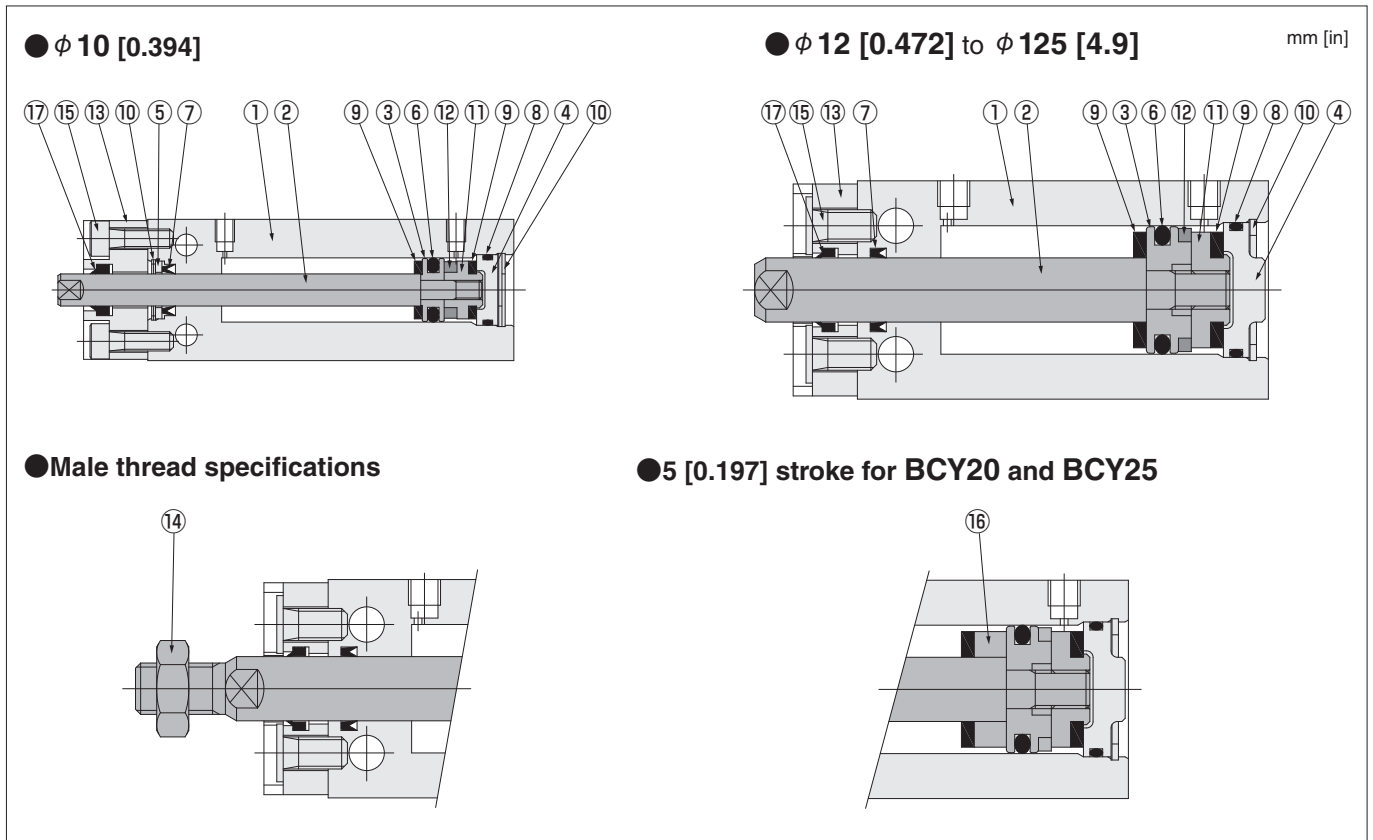

Major parts and materials (scraper specification)

No.	Name	φ 10 [0.394]	φ 12 [0.472]	φ 16 [0.630]	φ 20 [0.787]	φ 25 [0.984]	φ 32 [1.260]	φ 40 [1.575]	φ 50 [1.969]	φ 63 [2.480]	φ 80 [3.150]	φ 100 [3.9]	φ 125 [4.9]	
①	Cylinder body	Aluminum alloy (special anti-abrasion treated)												
②	Piston rod	Stainless steel												
③	Piston	Stainless steel			Aluminum alloy (anodized)									
④	Head cover	Aluminum alloy (anodized)												
⑤	Seal holder	Aluminum alloy (Anodized)	—	—	—	—	—	—	—	—	—	—	—	
⑥	★Piston seal	Synthetic rubber (NBR)												
⑦	★Rod seal	Synthetic rubber (NBR)												
⑧	★O-ring	Synthetic rubber (NBR)												
⑨	Bumper	Synthetic rubber (NBR)												
⑩	★Retaining ring	Stainless steel	Steel (electroless nickel plated)											
⑪	Support	Aluminum alloy (anodized)												
⑫	Magnet	Neodymium magnet						Plastic magnet						
⑬	Scraper block	Aluminum alloy (anodized)												
⑭	Rod end nut	Stainless steel												
⑮	Bolt	Stainless steel												
⑯	Stopper ^{Note}	—	—	—	Aluminum alloy (anodized)	—	—	—	—	—	—	—	—	
⑰	Scraper	Synthetic rubber (NBR)												

Items indicated by a ★ are available as additional parts or in packing sets. For order codes, see page 30.

Note: Only stroke 5 [0.197] has a collar stopper.

- BC6
- BCR6 (corrosion resistant specification)
- BCF6 (heat resistant specification)
- CSL-BC6 (clean room specification, without dust collection port)

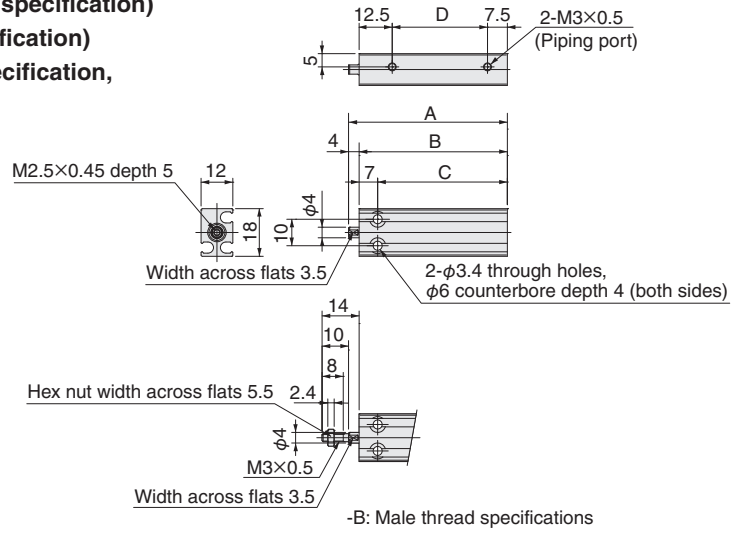

Stroke	A	B	C	D
5	35	31	24	11
10	40	36	29	16
15	45	41	34	21
20	50	46	39	26
25	55	51	44	31
30	60	56	49	36

Note: This product cannot use reed switch type sensor switches.

- BC8
- BCR8 (corrosion resistant specification)
- BCF8 (heat resistant specification)
- CSL-BC8 (clean room specification, without dust collection port)

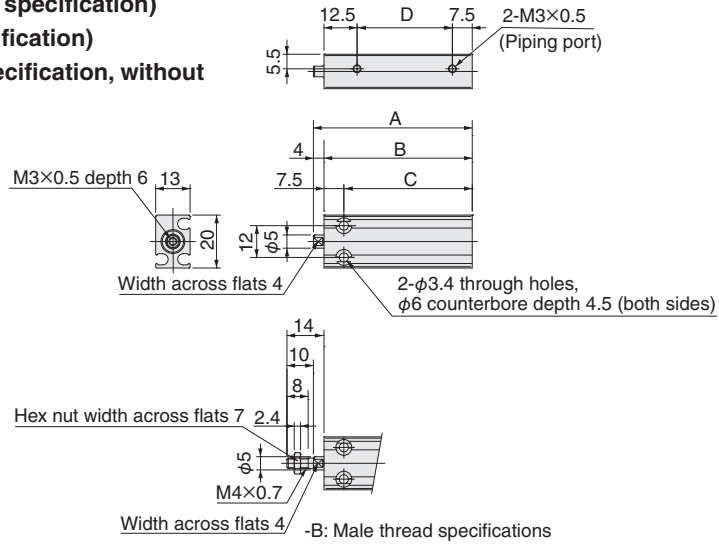

Stroke	A	B	C	D
5	35	31	23.5	11
10	40	36	28.5	16
15	45	41	33.5	21
20	50	46	38.5	26
25	55	51	43.5	31
30	60	56	48.5	36

Note: This product cannot use reed switch type sensor switches.

- BC6
- BCR6 (corrosion resistant specification)
- BCF6 (heat resistant specification)
- CSL-BC6 (clean room specification, without dust collection port)

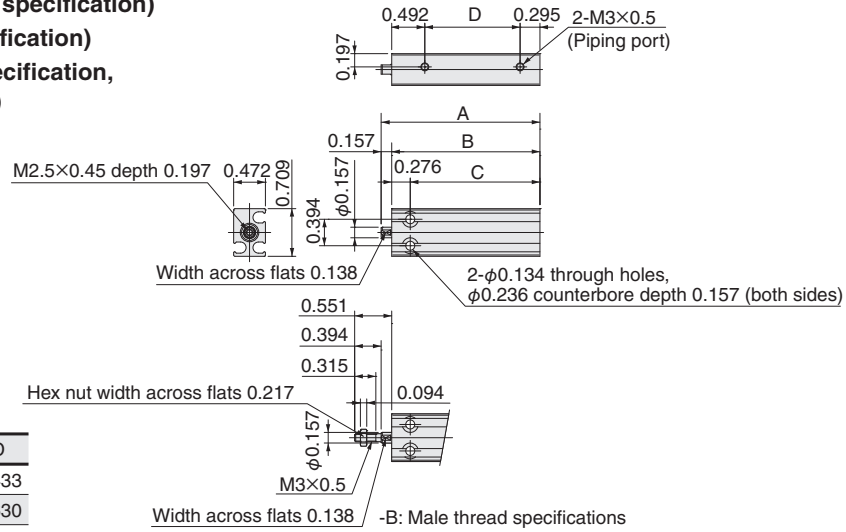

Stroke	A	B	C	D
5 mm [0.197]	1.378	1.220	0.945	0.433
10 mm [0.394]	1.575	1.417	1.142	0.630
15 mm [0.591]	1.772	1.614	1.339	0.827
20 mm [0.787]	1.969	1.811	1.535	1.024
25 mm [0.984]	2.165	2.008	1.732	1.220
30 mm [1.181]	2.362	2.205	1.929	1.417

Note: This product cannot use reed switch type sensor switches.

- BC8
- BCR8 (corrosion resistant specification)
- BCF8 (heat resistant specification)
- CSL-BC8 (clean room specification, without dust collection port)

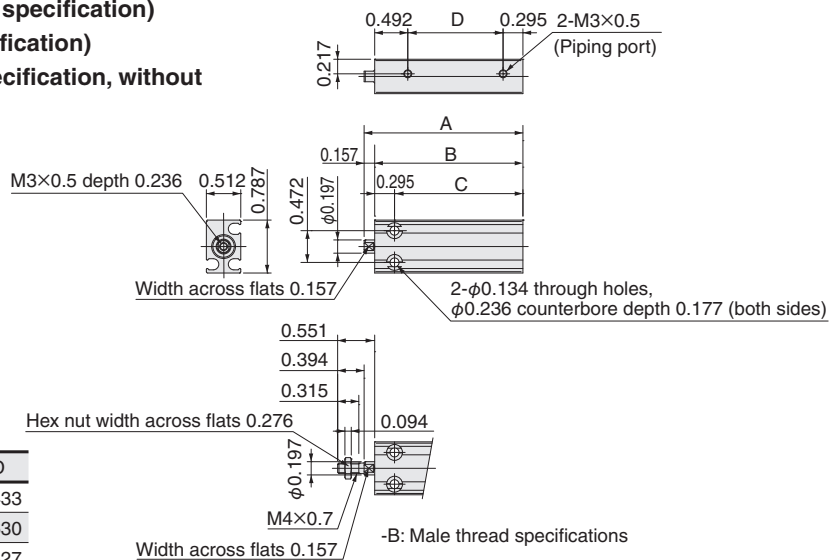

Stroke	A	B	C	D
5 mm [0.197]	1.378	1.220	0.925	0.433
10 mm [0.394]	1.575	1.417	1.122	0.630
15 mm [0.591]	1.772	1.614	1.319	0.827
20 mm [0.787]	1.969	1.811	1.516	1.024
25 mm [0.984]	2.165	2.008	1.713	1.220
30 mm [1.181]	2.362	2.205	1.909	1.417

Note: This product cannot use reed switch type sensor switches.

- BC10
- BCR10 (corrosion resistant specification)
- BCF10 (heat resistant specification)
- CSL-BC10 (clean room specification, without dust collection port)

* Refer to page 49 for scraper specification dimensions.

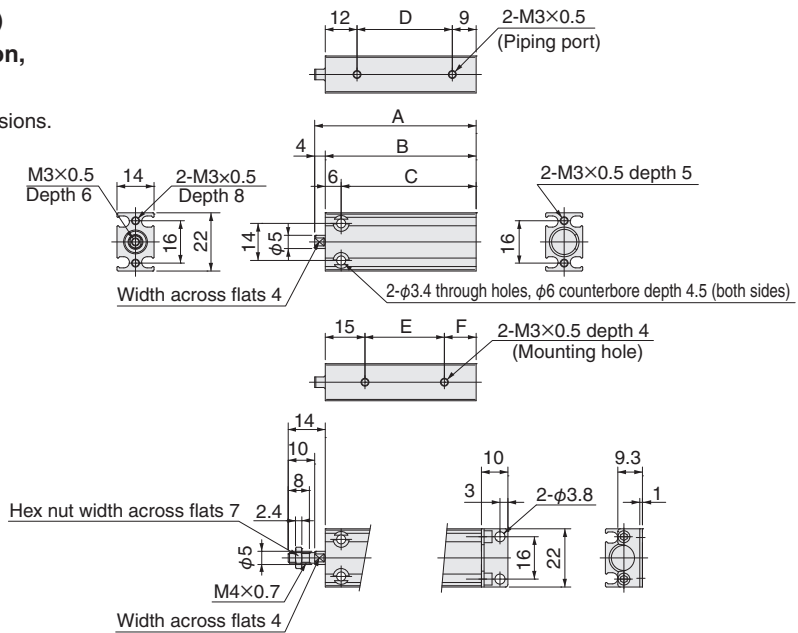

Stroke	A	B	C	D	E	F
5	36	32	26	11	8	9
10	41	37	31	16	10	12
15	46	42	36	21	10	17
20	51	47	41	26	20	12
25	56	52	46	31	20	17
30	61	57	51	36	30	12

-B: Male thread specifications -BK: With bracket (shipped attached)

Note: This product cannot use reed switch type sensor switches.

- BC12
- BCR12 (corrosion resistant specification)
- BCF12 (heat resistant specification)
- CSL-BC12 (clean room specification, without dust collection port)

* Refer to page 49 for scraper specification dimensions.

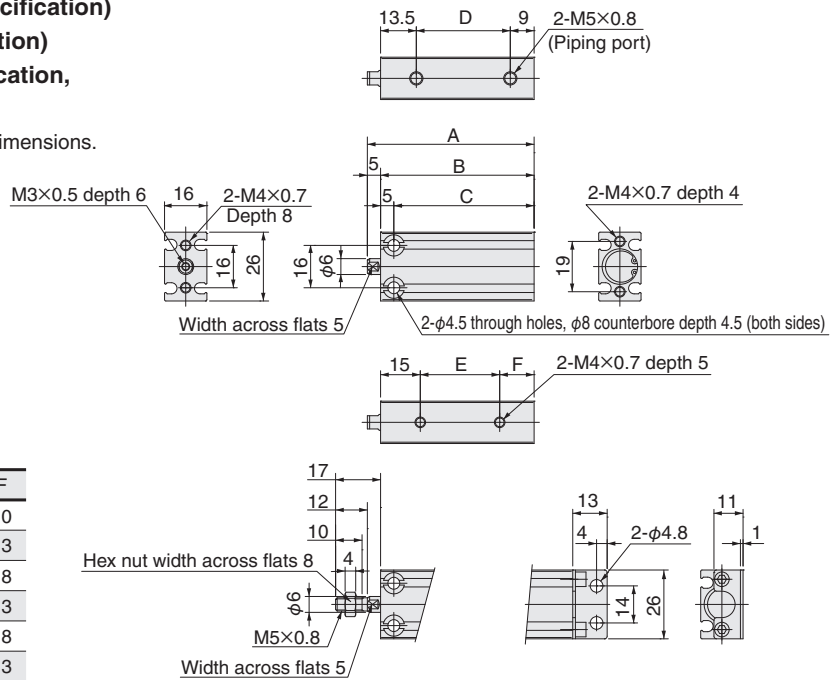

Stroke	A	B	C	D	E	F
5	38	33	28	10.5	8	10
10	43	38	33	15.5	10	13
15	48	43	38	20.5	10	18
20	53	48	43	25.5	20	13
25	58	53	48	30.5	20	18
30	63	58	53	35.5	30	13
35	68	63	58	40.5	30	18
40	73	68	63	45.5	40	13
45	78	73	68	50.5	40	18
50	83	78	73	55.5	50	13

-B: Male thread specifications -BK: With bracket (shipped attached)

Note: This product cannot use reed switch type sensor switches.

- BC10
- BCR10 (corrosion resistant specification)
- BCF10 (heat resistant specification)
- CSL-BC10 (clean room specification, without dust collection port)

* Refer to page 49 for scraper specification dimensions.

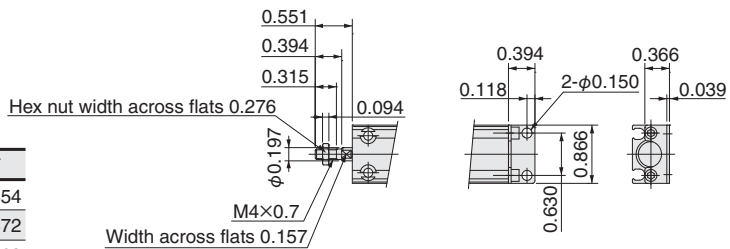
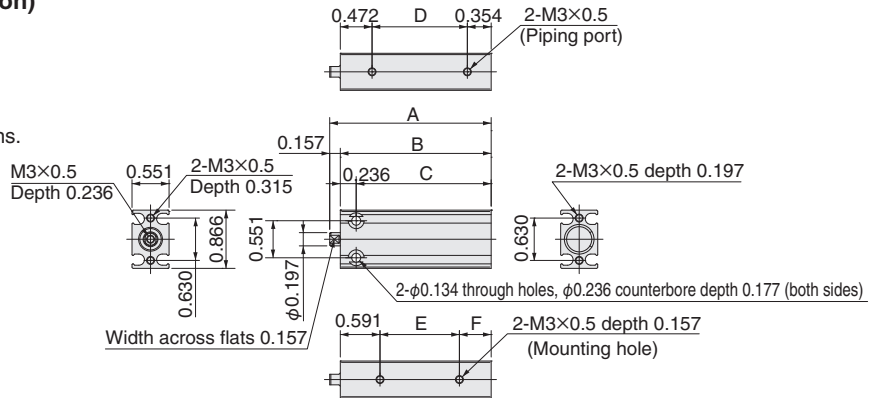

-B: Male thread specifications -BK: With bracket (shipped attached)

Note: This product cannot use reed switch type sensor switches.

Stroke	A	B	C	D	E	F
5 mm [0.197]	1.417	1.260	1.024	0.433	0.315	0.354
10 mm [0.394]	1.614	1.457	1.220	0.630	0.394	0.472
15 mm [0.591]	1.811	1.654	1.417	0.827	0.394	0.669
20 mm [0.787]	2.008	1.850	1.614	1.024	0.787	0.472
25 mm [0.984]	2.205	2.047	1.811	1.220	0.787	0.669
30 mm [1.181]	2.402	2.244	2.008	1.417	1.181	0.472

- BC12
- BCR12 (corrosion resistant specification)
- BCF12 (heat resistant specification)
- CSL-BC12 (clean room specification, without dust collection port)

* Refer to page 49 for scraper specification dimensions.

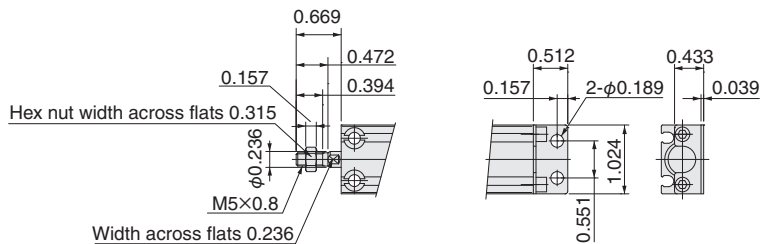
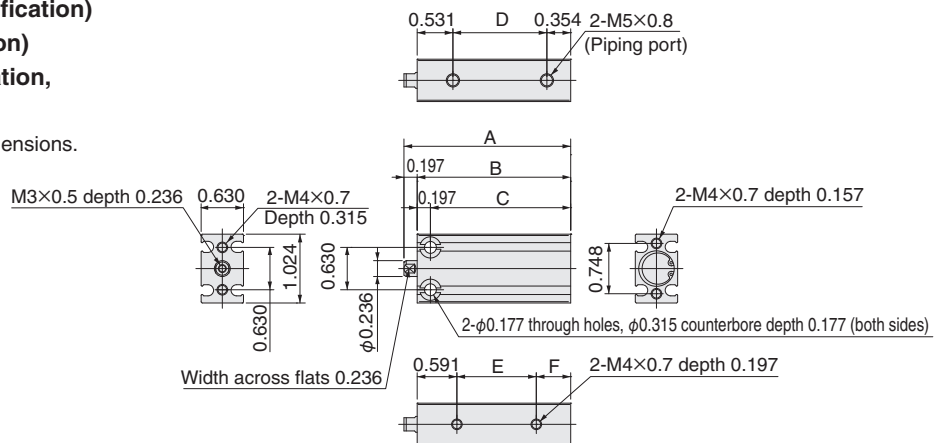

-B: Male thread specifications -BK: With bracket (shipped attached)

Note: This product cannot use reed switch type sensor switches.

Stroke	A	B	C	D	E	F
5 mm [0.197]	1.496	1.299	1.102	0.413	0.315	0.394
10 mm [0.394]	1.693	1.496	1.299	0.610	0.394	0.512
15 mm [0.591]	1.890	1.693	1.496	0.807	0.394	0.709
20 mm [0.787]	2.087	1.890	1.693	1.004	0.787	0.512
25 mm [0.984]	2.283	2.087	1.890	1.201	0.787	0.709
30 mm [1.181]	2.480	2.283	2.087	1.398	1.181	0.512
35 mm [1.378]	2.677	2.480	2.283	1.594	1.181	0.709
40 mm [1.575]	2.874	2.677	2.480	1.791	1.575	0.512
45 mm [1.772]	3.071	2.874	2.677	1.988	1.575	0.709
50 mm [1.969]	3.268	3.071	2.874	2.185	1.969	0.512

- BC16
- BCR16 (corrosion resistant specification)
- BCF16 (heat resistant specification)
- CSL-BC16 (clean room specification, without dust collection port)

* Refer to page 47 for scraper specification dimensions.

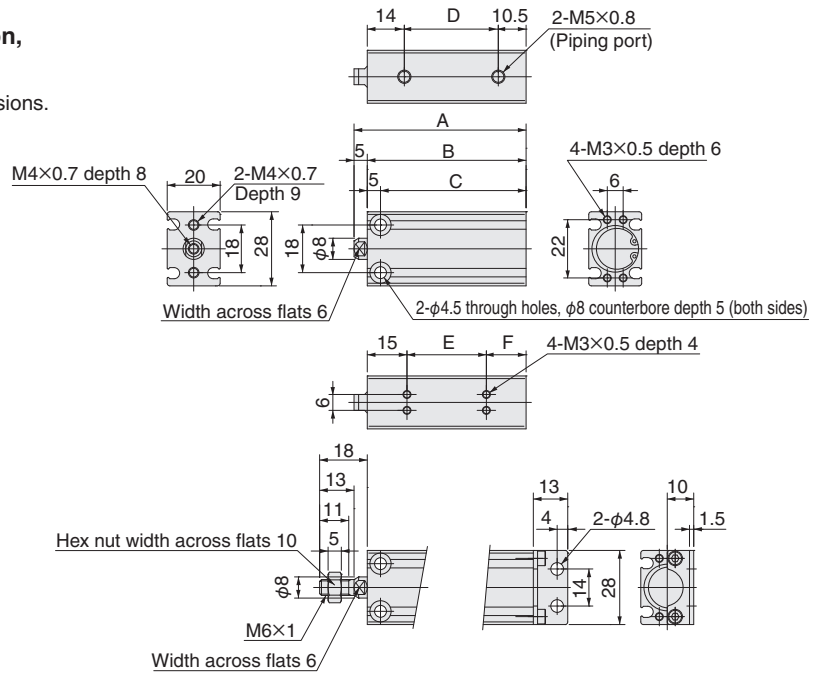

-B: Male thread specifications -BK: With bracket (shipped attached)

Stroke	A	B	C	D	E	F
5	40	35	30	10.5	10	10
10	45	40	35	15.5	10	15
15	50	45	40	20.5	10	20
20	55	50	45	25.5	20	15
25	60	55	50	30.5	20	20
30	65	60	55	35.5	30	15
35	70	65	60	40.5	30	20
40	75	70	65	45.5	40	15
45	80	75	70	50.5	40	20
50	85	80	75	55.5	50	15

- BC20
- BCR20 (corrosion resistant specification)
- BCF20 (heat resistant specification)
- CSL-BC20 (clean room specification, without dust collection port)

* Refer to page 47 for scraper specification dimensions.

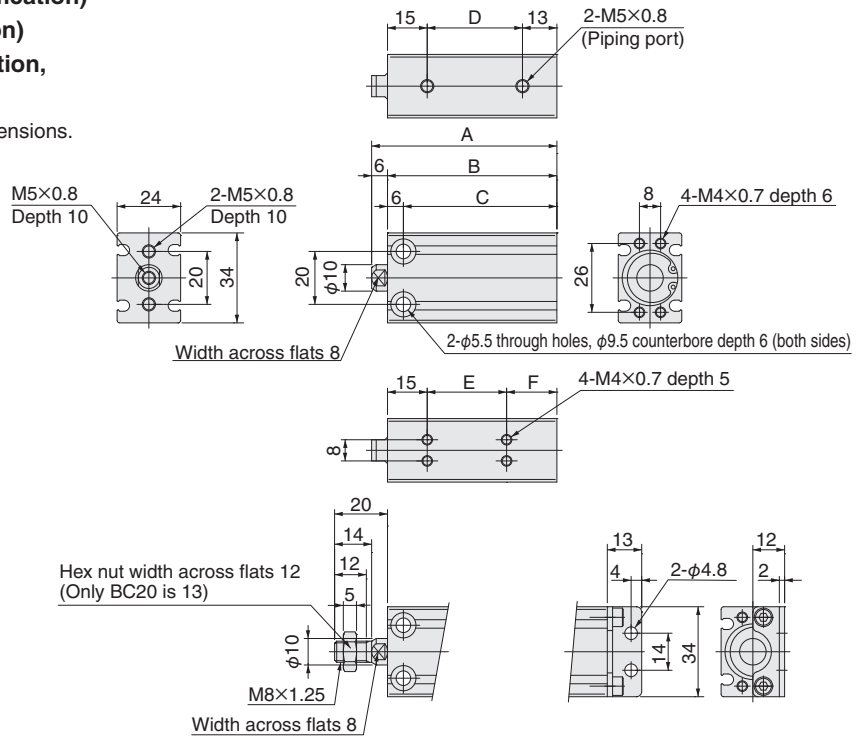

-B: Male thread specifications -BK: With bracket (shipped attached)

Stroke	A	B	C	D	E	F
5						
10	50	44	38	16	10	19
15	55	49	43	21	10	24
20	60	54	48	26	20	19
25	65	59	53	31	20	24
30	70	64	58	36	30	19
35	75	69	63	41	30	24
40	80	74	68	46	40	19
45	85	79	73	51	40	24
50	90	84	78	56	50	19
55	95	89	83	61	50	24
60	100	94	88	66	50	29
70	110	104	98	76	70	19
75	115	109	103	81	70	24
80	120	114	108	86	70	29
90	130	124	118	96	90	19
100	140	134	128	106	90	29

Note: 5 stroke supports collar stopper.

- BC16
- BCR16 (corrosion resistant specification)
- BCF16 (heat resistant specification)
- CSL-BC16 (clean room specification, without dust collection port)

* Refer to page 49 for scraper specification dimensions.

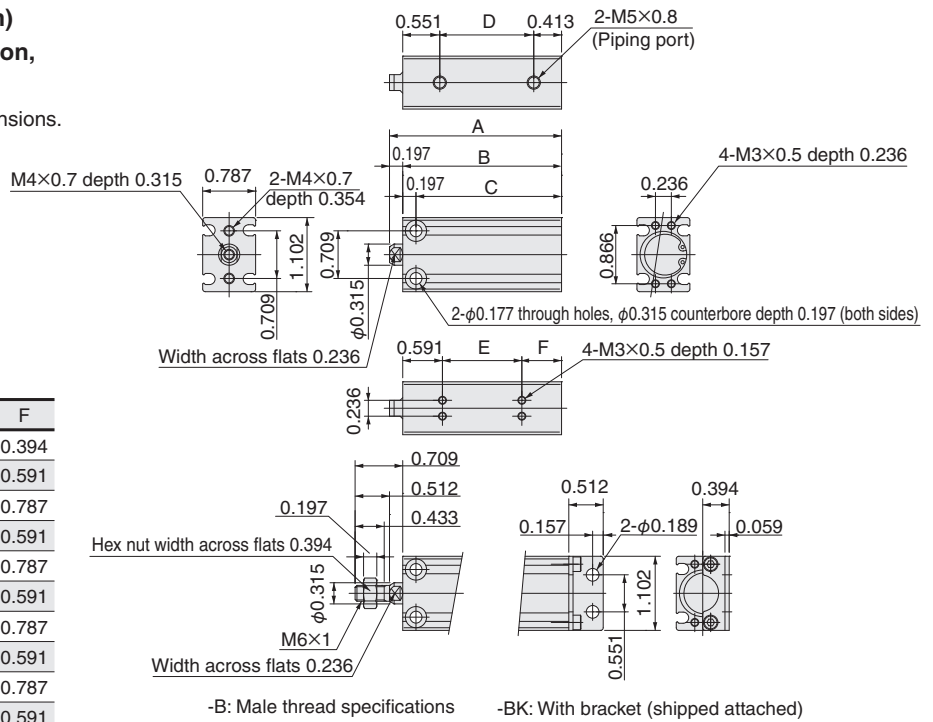

Stroke	A	B	C	D	E	F
5 mm [0.197]	1.575	1.378	1.181	0.413	0.394	0.394
10 mm [0.394]	1.772	1.575	1.378	0.610	0.394	0.591
15 mm [0.591]	1.969	1.772	1.575	0.807	0.394	0.787
20 mm [0.787]	2.165	1.969	1.772	1.004	0.787	0.591
25 mm [0.984]	2.362	2.165	1.969	1.201	0.787	0.787
30 mm [1.181]	2.559	2.362	2.165	1.398	1.181	0.591
35 mm [1.378]	2.756	2.559	2.362	1.594	1.181	0.787
40 mm [1.575]	2.953	2.756	2.559	1.791	1.575	0.591
45 mm [1.772]	3.150	2.953	2.756	1.988	1.575	0.787
50 mm [1.969]	3.346	3.150	2.953	2.185	1.969	0.591

- BC20
- BCR20 (corrosion resistant specification)
- BCF20 (heat resistant specification)
- CSL-BC20 (clean room specification, without dust collection port)

* Refer to page 49 for scraper specification dimensions.

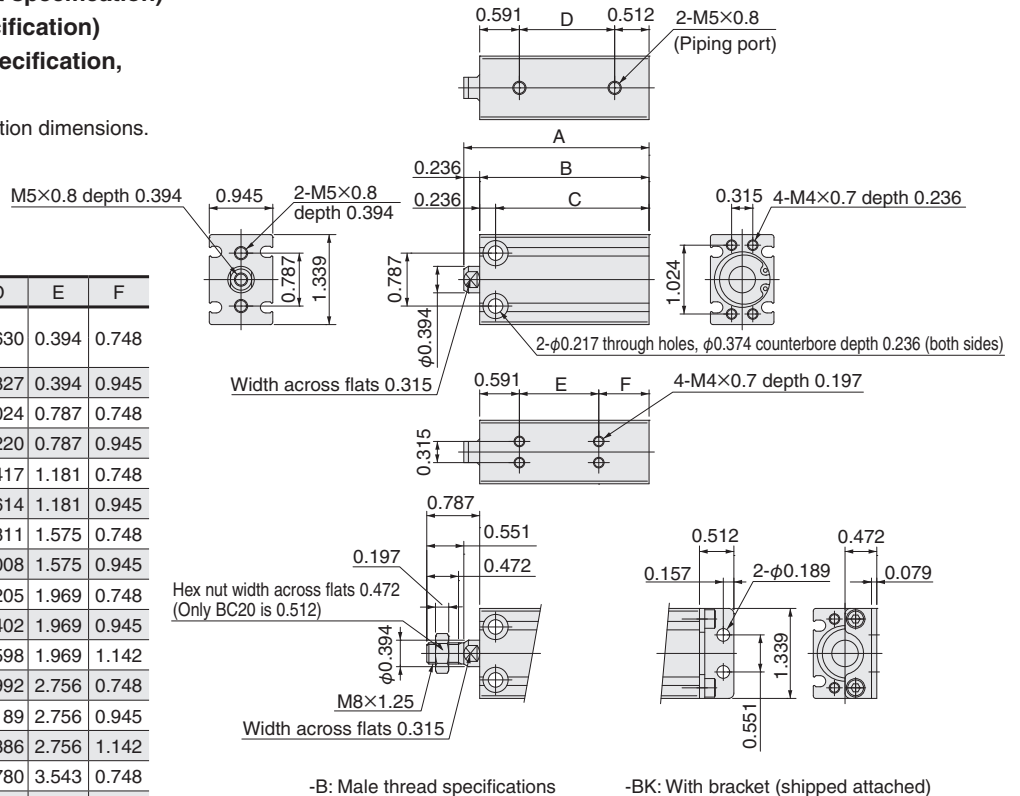

Stroke	A	B	C	D	E	F
5 mm [0.197]	1.969	1.732	1.496	0.630	0.394	0.748
10 mm [0.394]	2.165	1.929	1.693	0.827	0.394	0.945
15 mm [0.591]	2.362	2.126	1.890	1.024	0.787	0.748
20 mm [0.787]	2.559	2.323	2.087	1.220	0.787	0.945
25 mm [0.984]	2.756	2.520	2.283	1.417	1.181	0.748
30 mm [1.181]	2.953	2.717	2.480	1.614	1.181	0.945
35 mm [1.378]	3.150	2.913	2.677	1.811	1.575	0.748
40 mm [1.575]	3.346	3.110	2.874	2.008	1.575	0.945
45 mm [1.772]	3.543	3.307	3.071	2.205	1.969	0.748
50 mm [1.969]	3.740	3.504	3.268	2.402	1.969	0.945
55 mm [2.165]	3.937	3.701	3.465	2.598	1.969	1.142
60 mm [2.362]	4.134	3.898	3.662	2.795	2.362	0.748
65 mm [2.559]	4.331	4.094	3.858	2.992	2.756	0.945
70 mm [2.756]	4.528	4.291	4.055	3.189	2.756	1.142
75 mm [2.953]	4.724	4.488	4.252	3.386	2.756	1.142
80 mm [3.150]	4.921	4.685	4.449	3.583	3.145	0.748
85 mm [3.346]	5.118	4.882	4.646	3.780	3.534	0.945
90 mm [3.543]	5.315	5.079	4.843	3.977	3.923	1.142
95 mm [3.740]	5.512	5.276	5.039	4.173	4.312	1.142

Note: 0.197 stroke supports collar stopper.

Double acting type dimensions

unit: mm

- BC25
- BCR25 (corrosion resistant specification)
- BCF25 (heat resistant specification)
- CSL-BC25 (clean room specification, without dust collection port)

* Refer to page 49 for scraper specification dimensions.

Stroke	A	B	C	D	E	F
5						
10	52	46	40	17	10	21
15	57	51	45	22	10	26
20	62	56	50	27	20	21
25	67	61	55	32	20	26
30	72	66	60	37	30	21
35	77	71	65	42	30	26
40	82	76	70	47	40	21
45	87	81	75	52	40	26
50	92	86	80	57	50	21
55	97	91	85	62	50	26
60	102	96	90	67	50	31
70	112	106	100	77	70	21
75	117	111	105	82	70	26
80	122	116	110	87	70	31
90	132	126	120	97	90	21
100	142	136	130	107	90	31

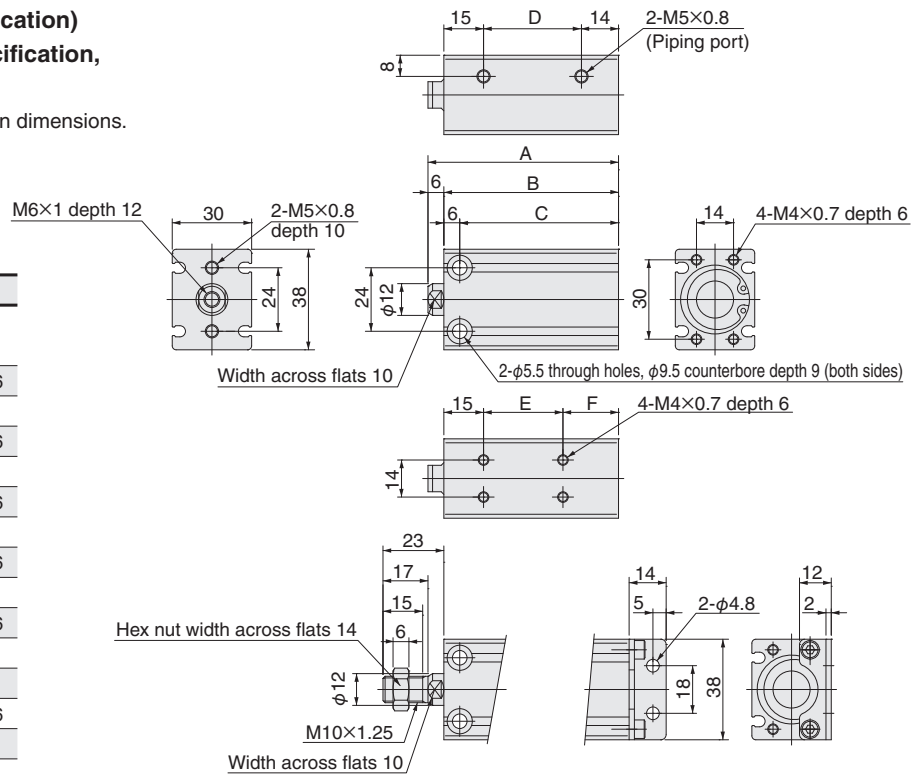

-B: Male thread specifications -BK: With bracket (shipped attached)

Note: 5 stroke supports collar stopper.

- BC32
- BCR32 (corrosion resistant specification)
- BCF32 (heat resistant specification)
- CSL-BC32 (clean room specification, without dust collection port)

* Refer to page 49 for scraper specification dimensions.

Stroke	A	B	C	D	E	F
10	57	50	43	16	10	20
15	62	55	48	21	10	25
20	67	60	53	26	20	20
25	72	65	58	31	20	25
30	77	70	63	36	30	20
35	82	75	68	41	30	25
40	87	80	73	46	40	20
45	92	85	78	51	40	25
50	97	90	83	56	50	20
55	102	95	88	61	50	25
60	107	100	93	66	50	30
70	117	110	103	76	70	20
75	122	115	108	81	70	25
80	127	120	113	86	80	20
90	137	130	123	96	80	30
100	147	140	133	106	100	20

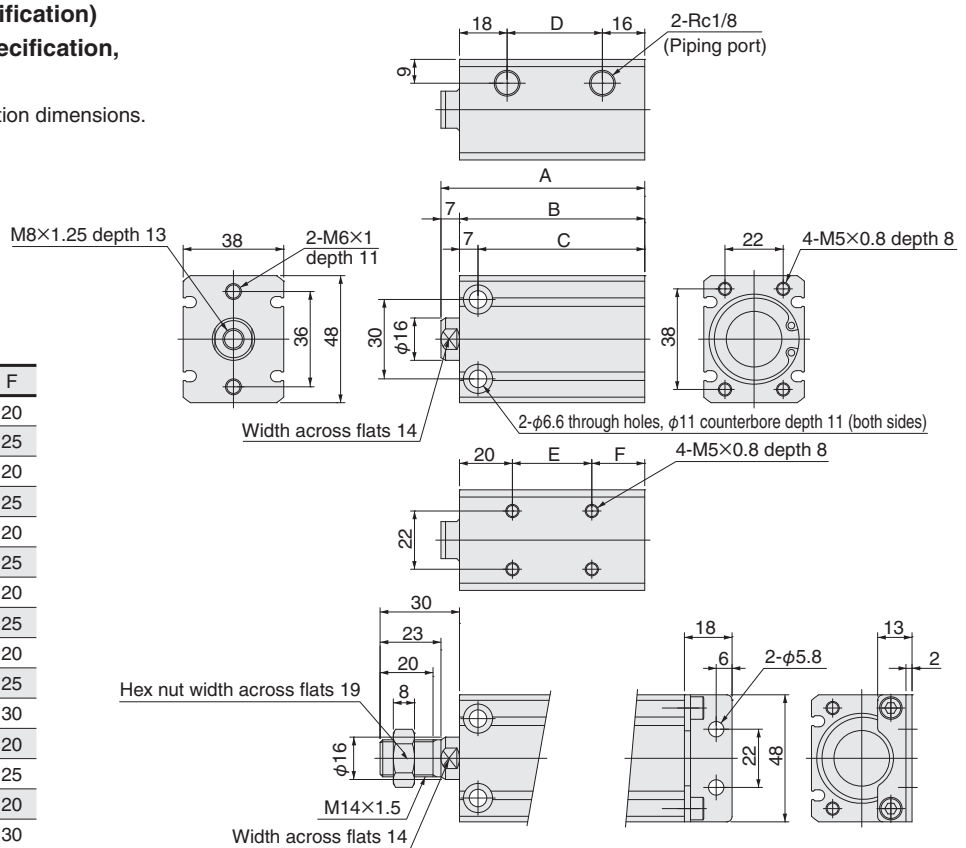

-B: Male thread specifications -BK: With bracket (shipped attached)

Double acting type dimensions

unit: in

- BC25
- BCR25 (corrosion resistant specification)
- BCF25 (heat resistant specification)
- CSL-BC25 (clean room specification, without dust collection port)

* Refer to page 50 for scraper specification dimensions.

Stroke	A	B	C	D	E	F
5 mm [0.197]						
10 mm [0.394]	2.047	1.811	1.575	0.669	0.394	0.827
15 mm [0.591]	2.244	2.008	1.772	0.866	0.394	1.024
20 mm [0.787]	2.441	2.205	1.969	1.063	0.787	0.827
25 mm [0.984]	2.638	2.402	2.165	1.260	0.787	1.024
30 mm [1.181]	2.835	2.598	2.362	1.457	1.181	0.827
35 mm [1.378]	3.031	2.795	2.559	1.654	1.181	1.024
40 mm [1.575]	3.228	2.992	2.756	1.850	1.575	0.827
45 mm [1.772]	3.425	3.189	2.953	2.047	1.575	1.024
50 mm [1.969]	3.622	3.386	3.150	2.244	1.969	0.827
55 mm [2.165]	3.819	3.583	3.346	2.441	1.969	1.024
60 mm [2.362]	4.016	3.780	3.543	2.638	1.969	1.220
70 mm [2.756]	4.409	4.173	3.937	3.031	2.756	0.827
75 mm [2.953]	4.606	4.370	4.134	3.228	2.756	1.024
80 mm [3.150]	4.803	4.567	4.331	3.425	2.756	1.220
90 mm [3.543]	5.197	4.961	4.724	3.819	3.543	0.827
100 mm [3.937]	5.591	5.354	5.118	4.213	3.543	1.220

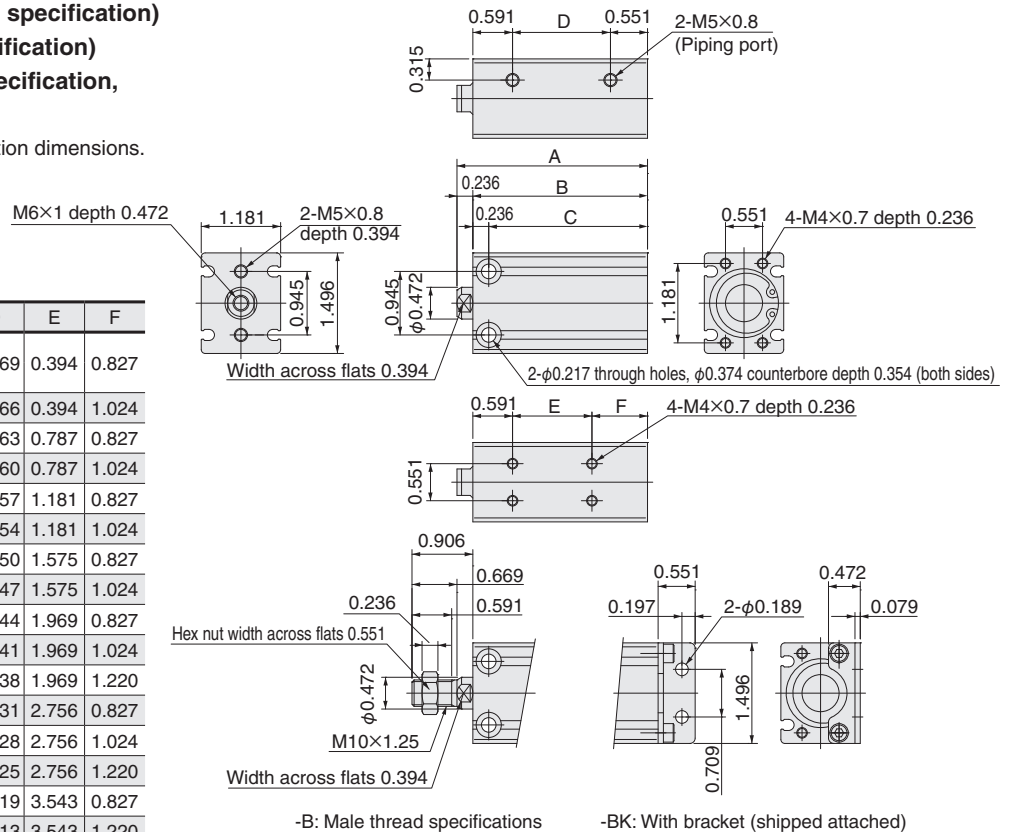

-B: Male thread specifications -BK: With bracket (shipped attached)

Note: 0.197 stroke supports collar stopper.

- BC32
- BCR32 (corrosion resistant specification)
- BCF32 (heat resistant specification)
- CSL-BC32 (clean room specification, without dust collection port)

* Refer to page 50 for scraper specification dimensions.

Stroke	A	B	C	D	E	F
10 mm [0.394]	2.244	1.969	1.693	0.630	0.394	0.787
15 mm [0.591]	2.441	2.165	1.890	0.827	0.394	0.984
20 mm [0.787]	2.638	2.362	2.087	1.024	0.787	0.787
25 mm [0.984]	2.835	2.559	2.283	1.220	0.787	0.984
30 mm [1.181]	3.031	2.756	2.480	1.417	1.181	0.787
35 mm [1.378]	3.228	2.953	2.677	1.614	1.181	0.984
40 mm [1.575]	3.425	3.150	2.874	1.811	1.575	0.787
45 mm [1.772]	3.622	3.346	3.071	2.008	1.575	0.984
50 mm [1.969]	3.819	3.543	3.268	2.205	1.969	0.787
55 mm [2.165]	4.016	3.740	3.465	2.402	1.969	0.984
60 mm [2.362]	4.213	3.937	3.661	2.598	1.969	1.181
70 mm [2.756]	4.606	4.331	4.055	2.992	2.756	0.787
75 mm [2.953]	4.803	4.528	4.252	3.189	2.756	0.984
80 mm [3.150]	5.000	4.724	4.449	3.386	3.150	0.787
90 mm [3.543]	5.394	5.118	4.843	3.780	3.150	1.181
100 mm [3.937]	5.787	5.512	5.236	4.173	3.937	0.787

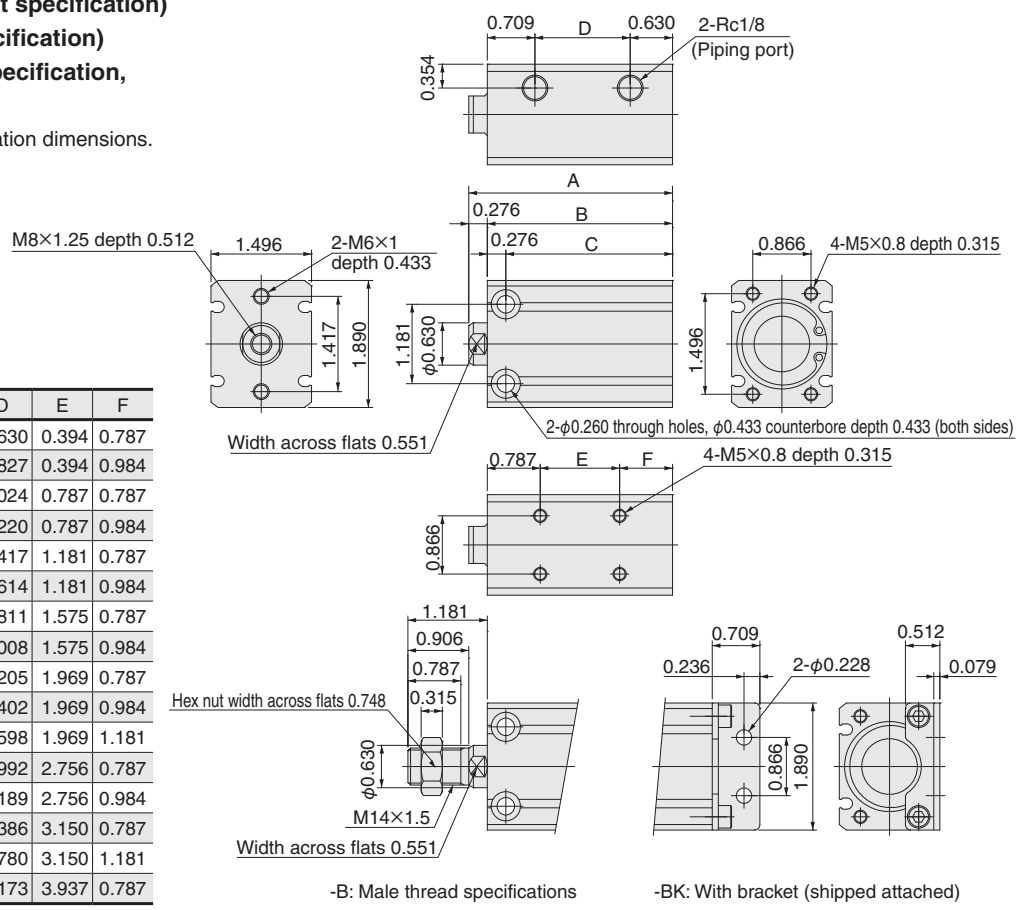

-B: Male thread specifications -BK: With bracket (shipped attached)

Double acting type dimensions

unit: mm

- BC40
- BCR40 (corrosion resistant specification)
- BCF40 (heat resistant specification)
- CSL-BC40 (clean room specification, without dust collection port)

* Refer to page 51 for scraper specification dimensions.

Stroke	A	B	C	D	E	F
10	64	57	48	17	15	27
15	69	62	53	22	15	32
20	74	67	58	27	20	27
25	79	72	63	32	20	32
30	84	77	68	37	30	27
35	89	82	73	42	30	32
40	94	87	78	47	40	27
45	99	92	83	52	40	32
50	104	97	88	57	50	27
55	109	102	93	62	50	32
60	114	107	98	67	60	27
70	124	117	108	77	70	27
75	129	122	113	82	70	32
80	134	127	118	87	80	27
90	144	137	128	97	80	37
100	154	147	138	107	100	27

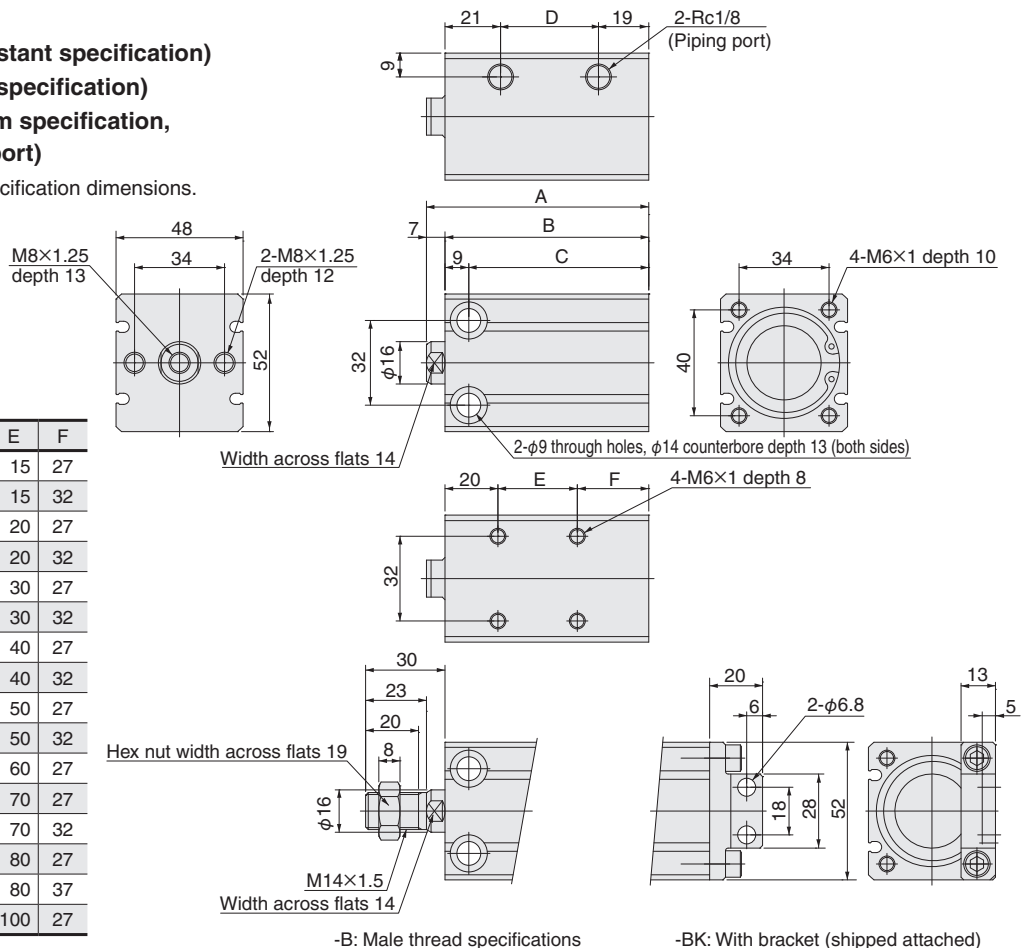

-B: Male thread specifications

-BK: With bracket (shipped attached)

- BC50
- BCR50 (corrosion resistant specification)
- BCF50 (heat resistant specification)
- CSL-BC50 (clean room specification, without dust collection port)

* Refer to page 51 for scraper specification dimensions.

Stroke	A	B	C	D
10	71	63	52	18
15	76	68	57	23
20	81	73	62	28
25	86	78	67	33
30	91	83	72	38
35	96	88	77	43
40	101	93	82	48
45	106	98	87	53
50	111	103	92	58
55	116	108	97	63
60	121	113	102	68
70	131	123	112	78
75	136	128	117	83
80	141	133	122	88
90	151	143	132	98
100	161	153	142	108

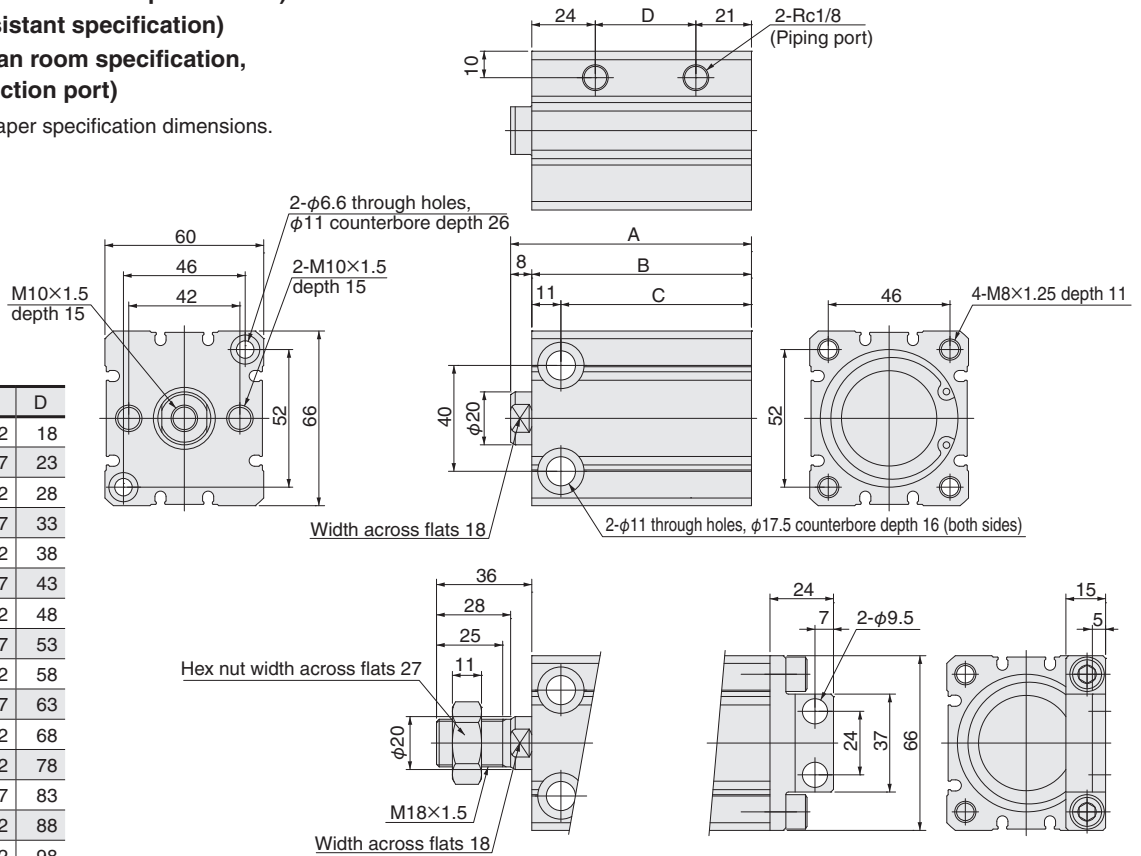

-B: Male thread specifications

-BK: With bracket (shipped attached)

Double acting type dimensions

unit: in

- BC40
- BCR40 (corrosion resistant specification)
- BCF40 (heat resistant specification)
- CSL-BC40 (clean room specification, without dust collection port)

* Refer to page 52 for scraper specification dimensions.

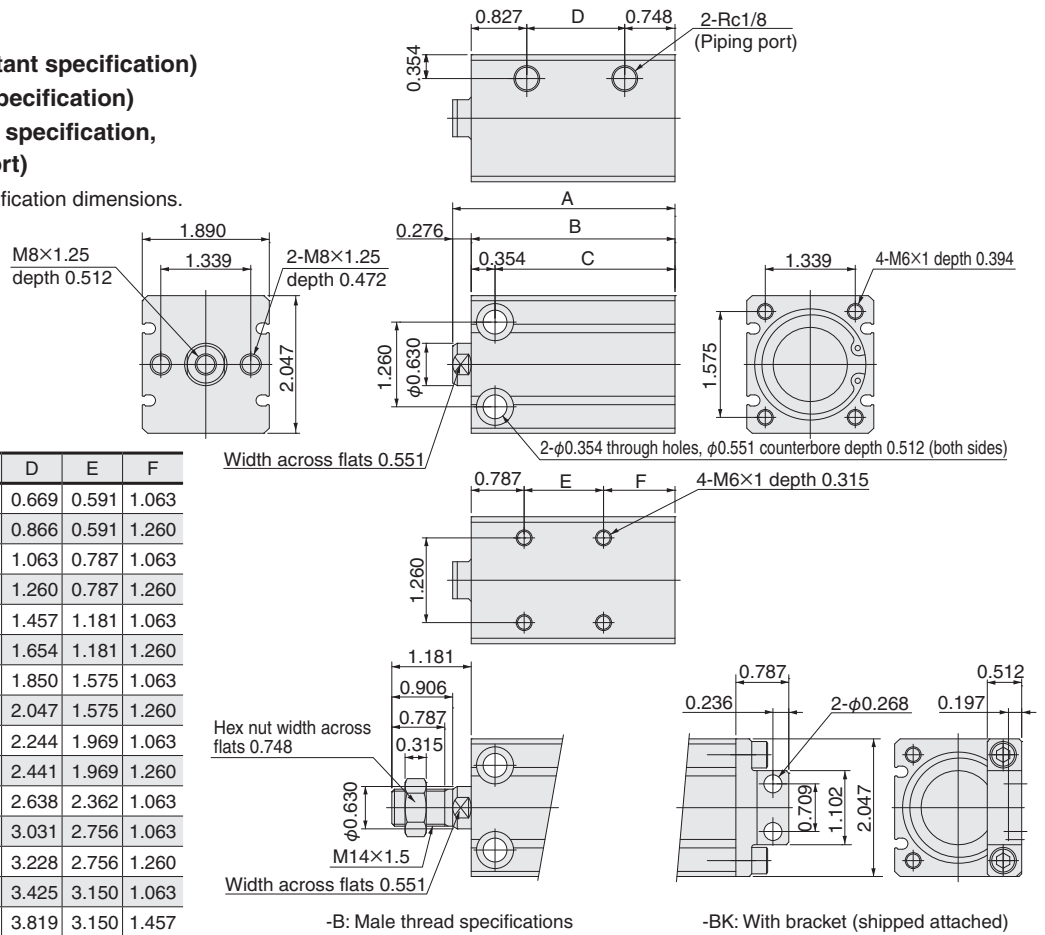

Stroke	A	B	C	D	E	F
10 mm [0.394]	2.520	2.244	1.890	0.669	0.591	1.063
15 mm [0.591]	2.717	2.441	2.087	0.866	0.591	1.260
20 mm [0.787]	2.913	2.638	2.283	1.063	0.787	1.063
25 mm [0.984]	3.110	2.835	2.480	1.260	0.787	1.260
30 mm [1.181]	3.307	3.031	2.677	1.457	1.181	1.063
35 mm [1.378]	3.504	3.228	2.874	1.654	1.181	1.260
40 mm [1.575]	3.701	3.425	3.071	1.850	1.575	1.063
45 mm [1.772]	3.898	3.622	3.268	2.047	1.575	1.260
50 mm [1.969]	4.094	3.819	3.465	2.244	1.969	1.063
55 mm [2.165]	4.291	4.016	3.661	2.441	1.969	1.260
60 mm [2.362]	4.488	4.213	3.858	2.638	2.362	1.063
70 mm [2.756]	4.882	4.606	4.252	3.031	2.756	1.063
75 mm [2.953]	5.079	4.803	4.449	3.228	2.756	1.260
80 mm [3.150]	5.276	5.000	4.646	3.425	3.150	1.063
90 mm [3.543]	5.669	5.394	5.039	3.819	3.150	1.457
100 mm [3.937]	6.063	5.787	5.433	4.213	3.937	1.063

- BC50
- BCR50 (corrosion resistant specification)
- BCF50 (heat resistant specification)
- CSL-BC50 (clean room specification, without dust collection port)

* Refer to page 52 for scraper specification dimensions.

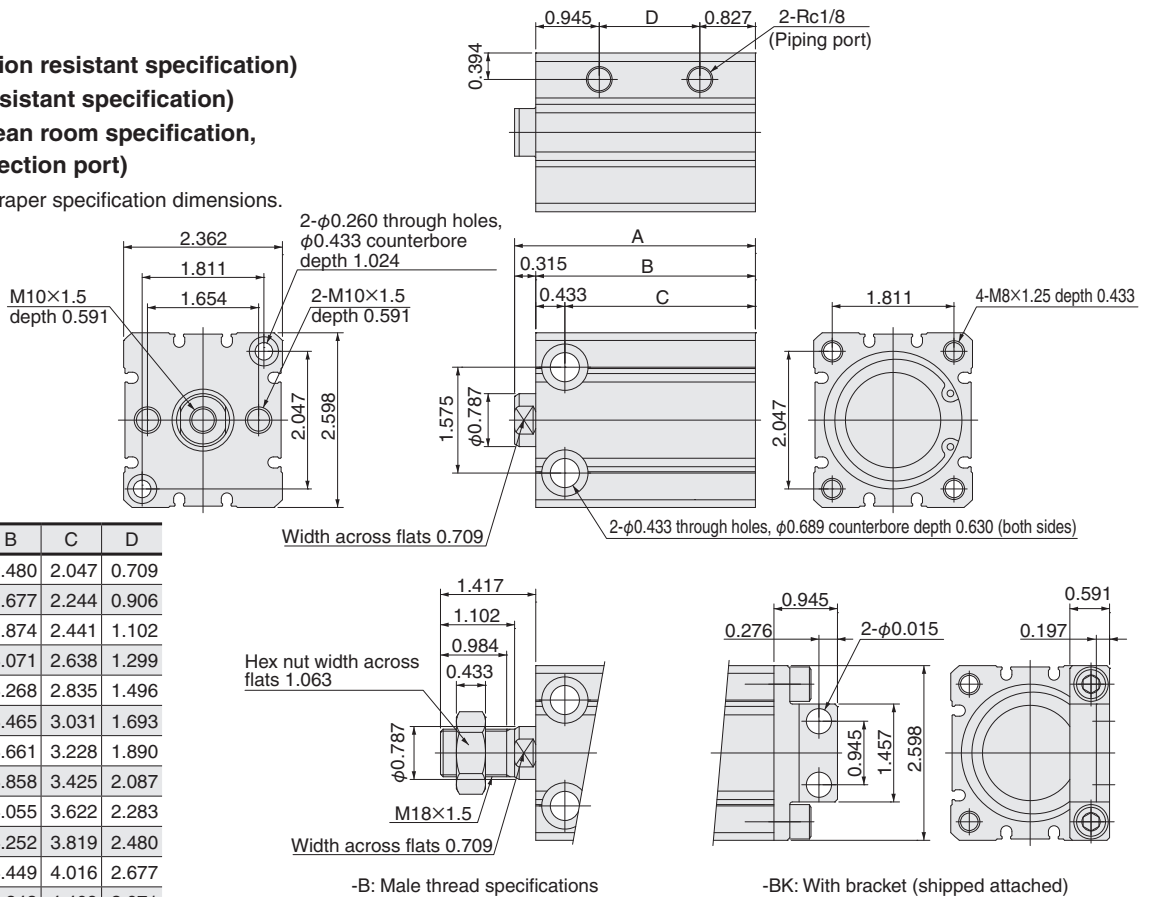

Stroke	A	B	C	D
10 mm [0.394]	2.795	2.480	2.047	0.709
15 mm [0.591]	2.992	2.677	2.244	0.906
20 mm [0.787]	3.189	2.874	2.441	1.102
25 mm [0.984]	3.386	3.071	2.638	1.299
30 mm [1.181]	3.583	3.268	2.835	1.496
35 mm [1.378]	3.780	3.465	3.031	1.693
40 mm [1.575]	3.976	3.661	3.228	1.890
45 mm [1.772]	4.173	3.858	3.425	2.087
50 mm [1.969]	4.370	4.055	3.622	2.283
55 mm [2.165]	4.567	4.252	3.819	2.480
60 mm [2.362]	4.764	4.449	4.016	2.677
70 mm [2.756]	5.157	4.843	4.409	3.071
75 mm [2.953]	5.354	5.039	4.606	3.268
80 mm [3.150]	5.551	5.236	4.803	3.465
90 mm [3.543]	5.945	5.630	5.197	3.858
100 mm [3.937]	6.339	6.024	5.591	4.252

Double acting type dimensions

unit: mm

- BC63
- BCR63 (corrosion resistant specification)
- BCF63 (heat resistant specification)
- CSL-BC63 (clean room specification, without dust collection port)

* Refer to page 59 for scraper specification dimensions.

Stroke	A	B	C	D
10	79	71	59	21
15	84	76	64	26
20	89	81	69	31
25	94	86	74	36
30	99	91	79	41
35	104	96	84	46
40	109	101	89	51
45	114	106	94	56
50	119	111	99	61
55	124	116	104	66
60	129	121	109	71
70	139	131	119	81
75	144	136	124	86
80	149	141	129	91
90	159	151	139	101
100	169	161	149	111

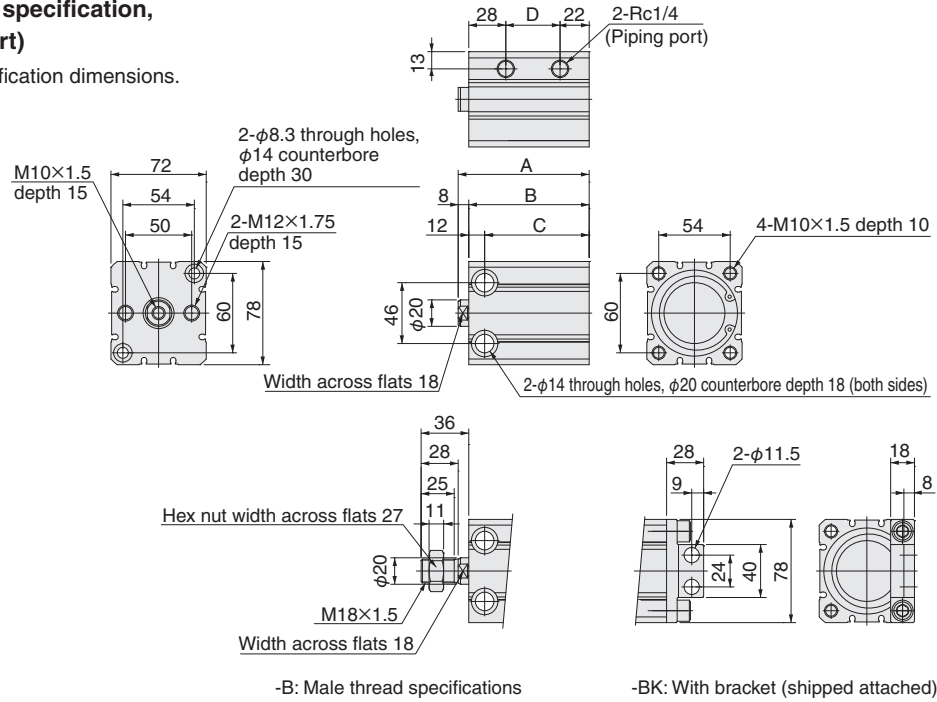

- BC80
- BCR80 (corrosion resistant specification)
- BCF80 (heat resistant specification)

* Refer to page 59 for scraper specification dimensions.

Stroke	A	B	C	D
10	84	74	62	24
15	89	79	67	29
20	94	84	72	34
25	99	89	77	39
30	104	94	82	44
35	109	99	87	49
40	114	104	92	54
45	119	109	97	59
50	124	114	102	64
55	129	119	107	69
60	134	124	112	74
70	144	134	122	84
75	149	139	127	89
80	154	144	132	94
90	164	154	142	104
100	174	164	152	114

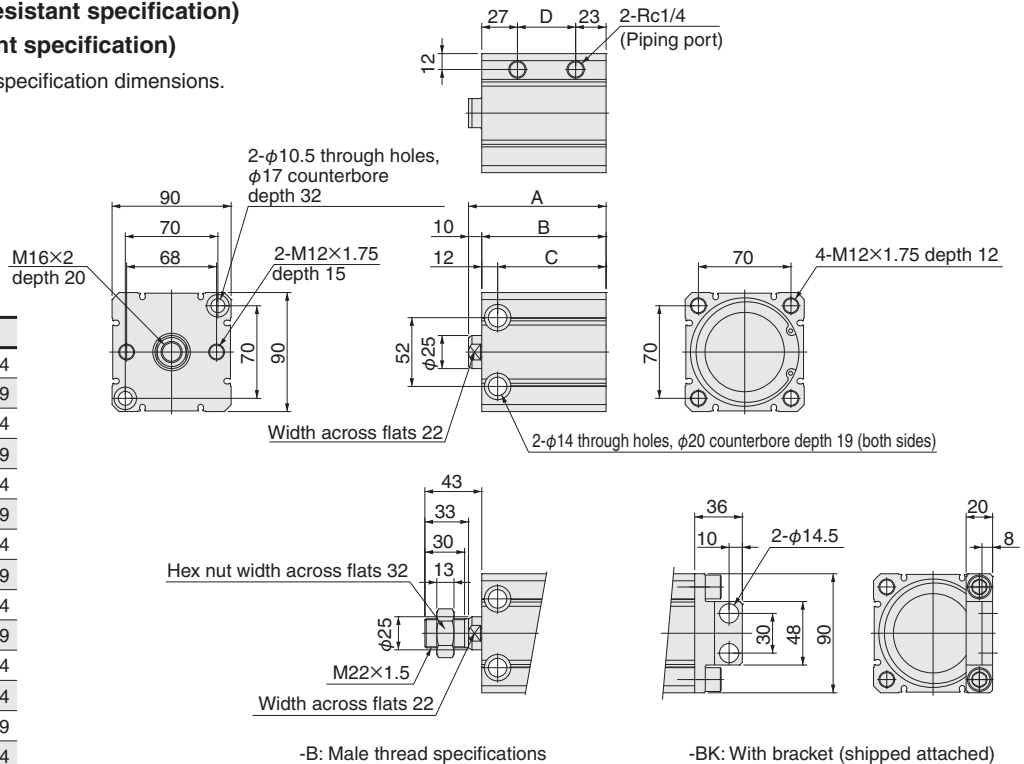

- BC63
- BCR63 (corrosion resistant specification)
- BCF63 (heat resistant specification)
- CSL-BC63 (clean room specification, without dust collection port)

* Refer to page 54 for scraper specification dimensions.

Stroke	A	B	C	D
10 mm [0.394]	3.110	2.795	2.323	0.827
15 mm [0.591]	3.307	2.992	2.520	1.024
20 mm [0.787]	3.504	3.189	2.717	1.220
25 mm [0.984]	3.701	3.386	2.913	1.417
30 mm [1.181]	3.898	3.583	3.110	1.614
35 mm [1.378]	4.094	3.780	3.307	1.811
40 mm [1.575]	4.291	3.976	3.504	2.008
45 mm [1.772]	4.488	4.173	3.701	2.205
50 mm [1.969]	4.685	4.370	3.898	2.402
55 mm [2.165]	4.882	4.567	4.094	2.598
60 mm [2.362]	5.079	4.764	4.291	2.795
70 mm [2.756]	5.472	5.157	4.685	3.189
75 mm [2.953]	5.669	5.354	4.882	3.386
80 mm [3.150]	5.866	5.551	5.079	3.583
90 mm [3.543]	6.260	5.945	5.472	3.976
100 mm [3.937]	6.654	6.339	5.866	4.370

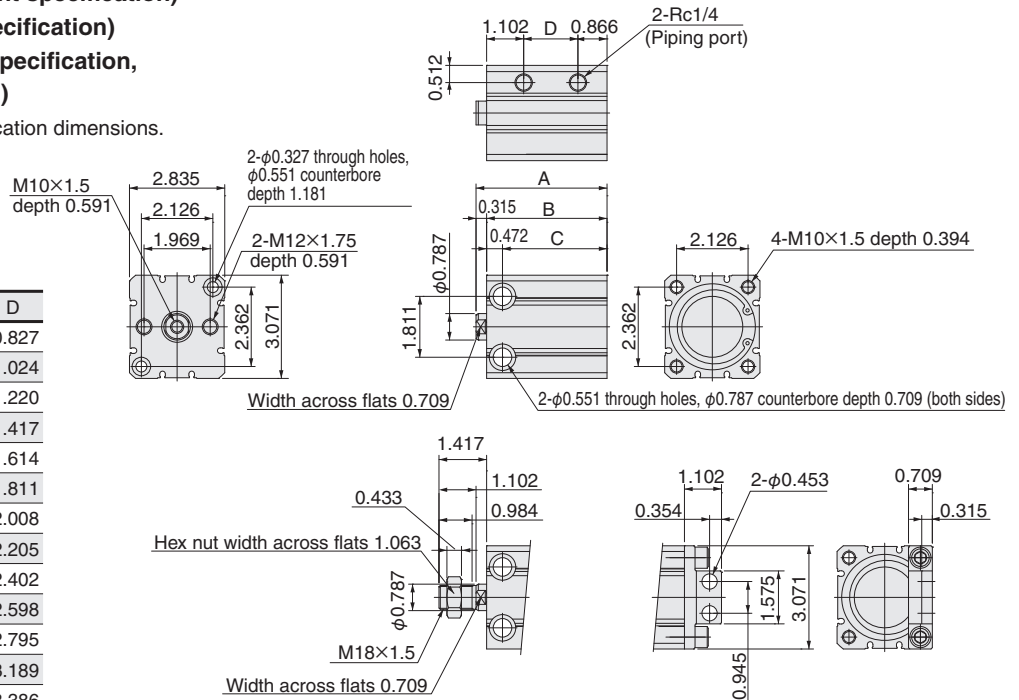

-B: Male thread specifications

-BK: With bracket (shipped attached)

- BC80
- BCR80 (corrosion resistant specification)
- BCF80 (heat resistant specification)

* Refer to page 54 for scraper specification dimensions.

Stroke	A	B	C	D
10 mm [0.394]	3.307	2.913	2.441	0.945
15 mm [0.591]	3.504	3.110	2.638	1.142
20 mm [0.787]	3.701	3.307	2.835	1.339
25 mm [0.984]	3.898	3.504	3.031	1.535
30 mm [1.181]	4.094	3.701	3.228	1.732
35 mm [1.378]	4.291	3.898	3.425	1.929
40 mm [1.575]	4.488	4.094	3.622	2.126
45 mm [1.772]	4.685	4.291	3.819	2.323
50 mm [1.969]	4.882	4.488	4.016	2.520
55 mm [2.165]	5.079	4.685	4.213	2.717
60 mm [2.362]	5.276	4.882	4.409	2.913
70 mm [2.756]	5.669	5.276	4.803	3.307
75 mm [2.953]	5.866	5.472	5.000	3.504
80 mm [3.150]	6.063	5.669	5.197	3.701
90 mm [3.543]	6.457	6.063	5.591	4.094
100 mm [3.937]	6.850	6.457	5.984	4.488

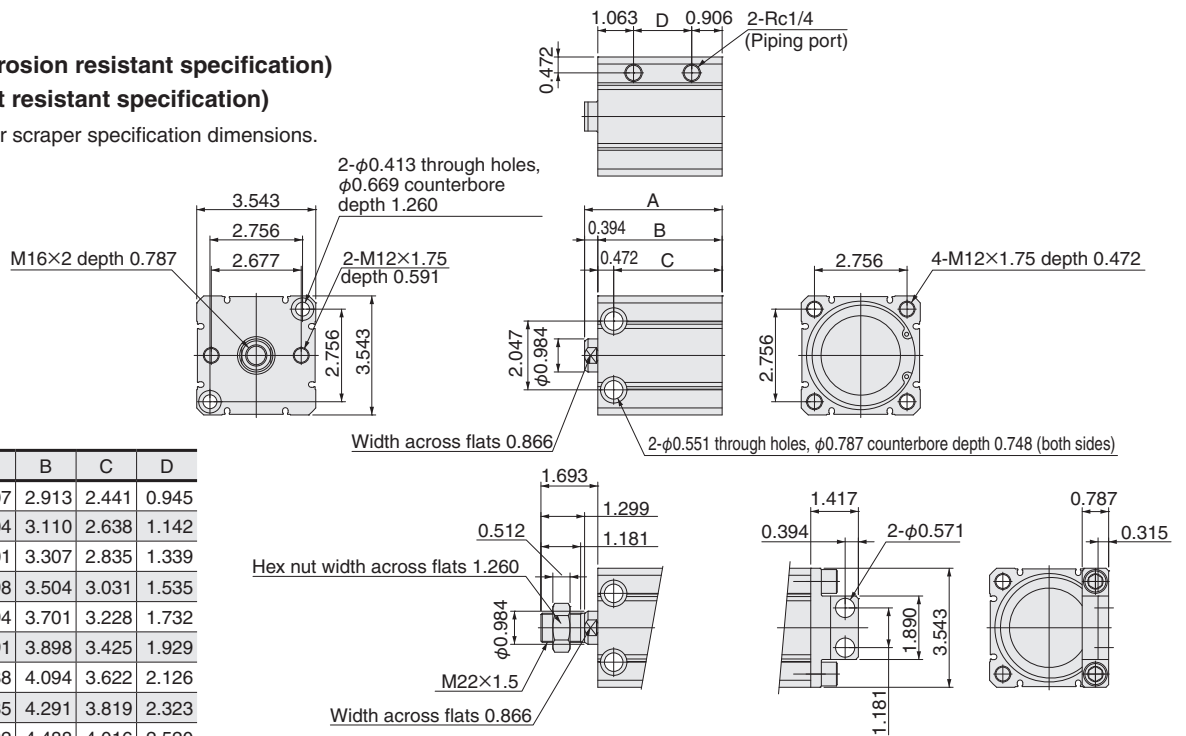

-B: Male thread specifications

-BK: With bracket (shipped attached)

Double acting type dimensions

unit: mm

- BC100
- BCR100 (corrosion resistant specification)
- BCF100 (heat resistant specification)

* Refer to page 55 for scraper specification dimensions.

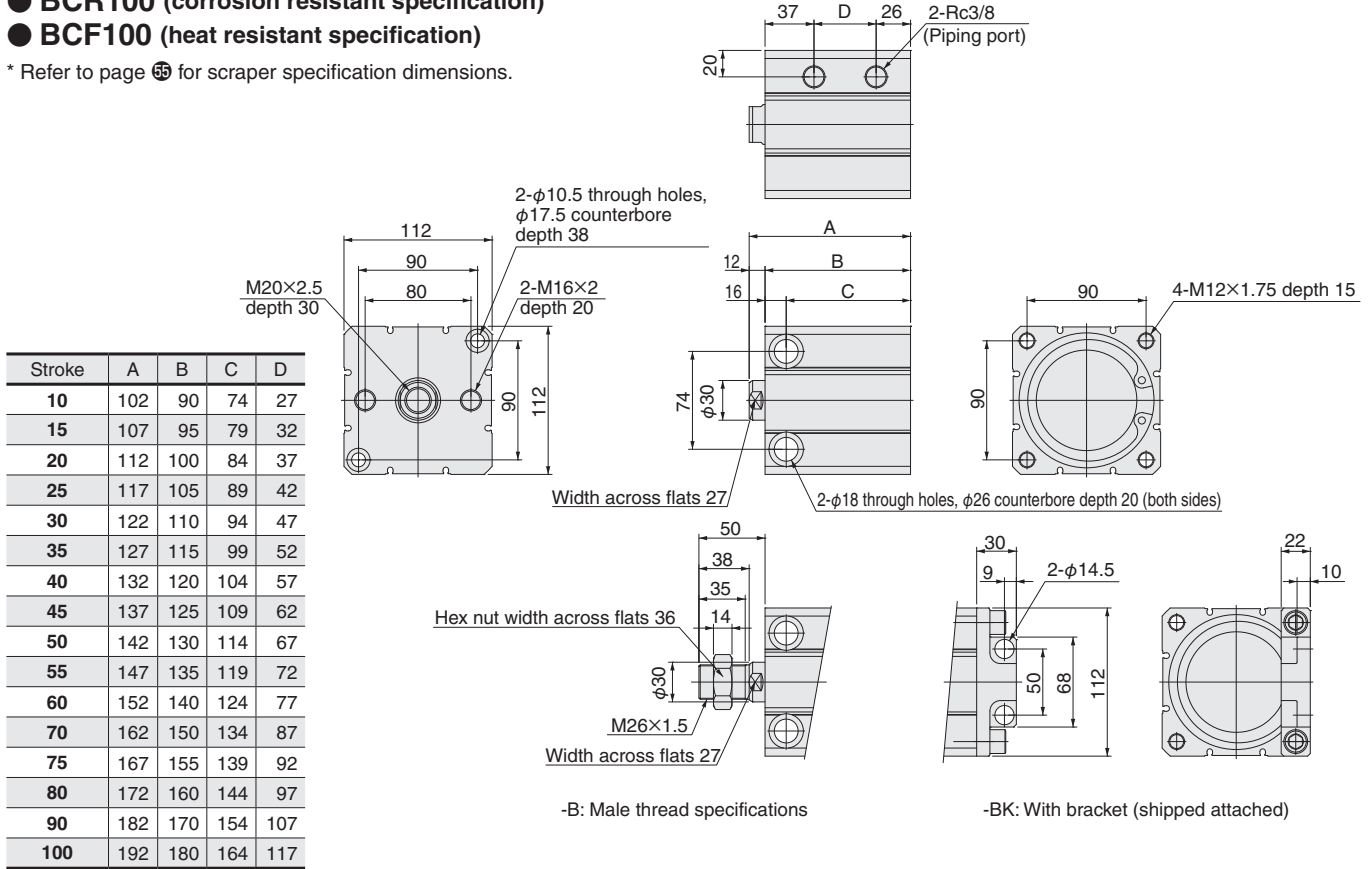

- BC125
- BCR125 (corrosion resistant specification)
- BCF125 (heat resistant specification)

* Refer to page 55 for scraper specification dimensions.

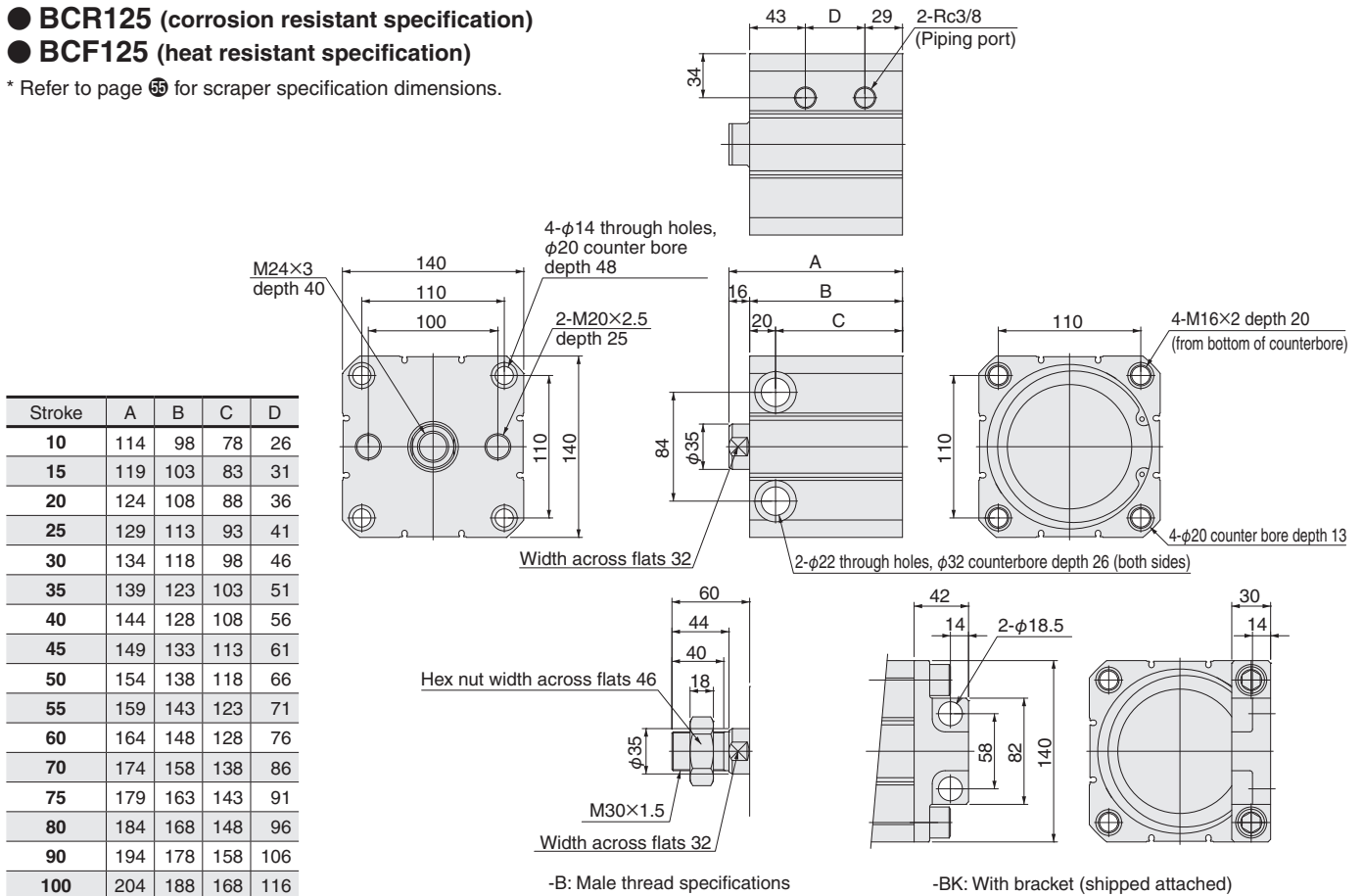

Double acting type dimensions

unit: in

- BC100
- BCR100 (corrosion resistant specification)
- BCF100 (heat resistant specification)

* Refer to page 59 for scraper specification dimensions.

Stroke	A	B	C	D
10 mm [0.394]	4.016	3.543	2.913	1.063
15 mm [0.591]	4.213	3.740	3.110	1.260
20 mm [0.787]	4.409	3.937	3.307	1.457
25 mm [0.984]	4.606	4.134	3.504	1.654
30 mm [1.181]	4.803	4.331	3.701	1.850
35 mm [1.378]	5.000	4.528	3.898	2.047
40 mm [1.575]	5.197	4.724	4.094	2.244
45 mm [1.772]	5.394	4.921	4.291	2.441
50 mm [1.969]	5.591	5.118	4.488	2.638
55 mm [2.165]	5.787	5.315	4.685	2.835
60 mm [2.362]	5.984	5.512	4.882	3.031
70 mm [2.756]	6.378	5.906	5.276	3.425
75 mm [2.953]	6.575	6.102	5.472	3.622
80 mm [3.150]	6.772	6.299	5.669	3.819
90 mm [3.543]	7.165	6.693	6.063	4.213
100 mm [3.937]	7.559	7.087	6.457	4.606

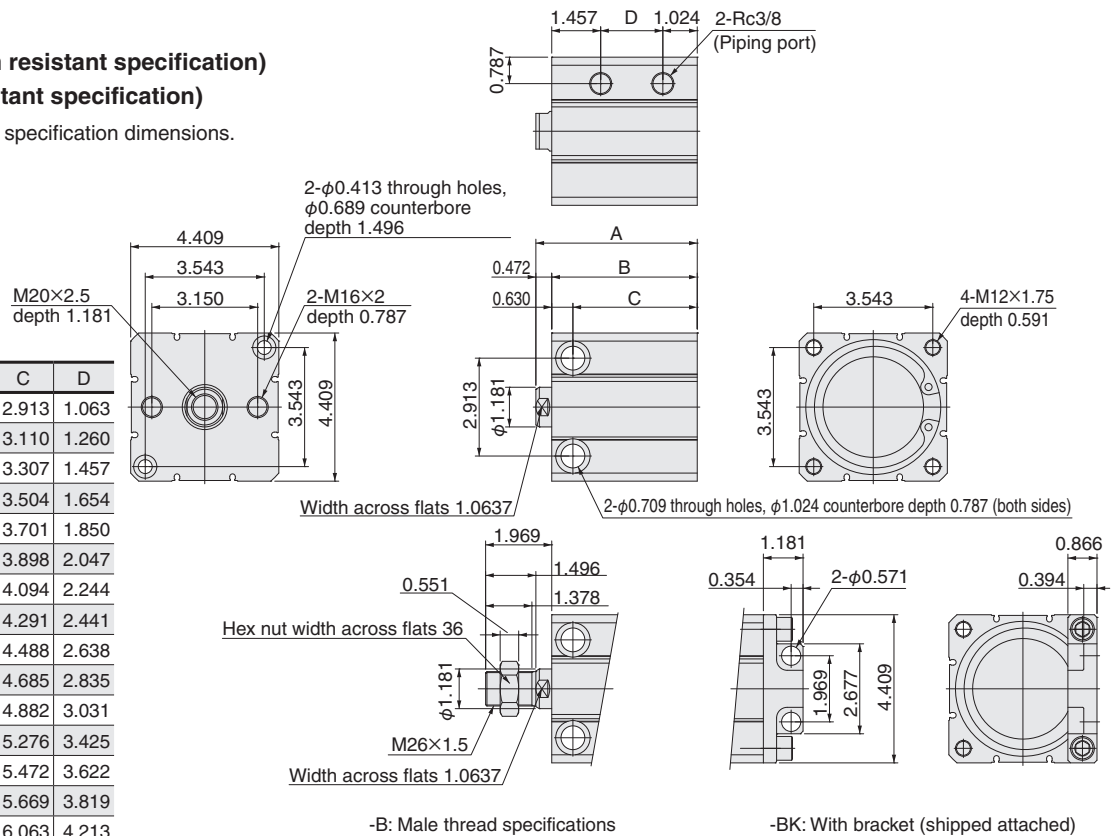

- BC125
- BCR125 (corrosion resistant specification)
- BCF125 (heat resistant specification)

* Refer to page 59 for scraper specification dimensions.

Stroke	A	B	C	D
10 mm [0.394]	4.488	3.858	3.071	1.024
15 mm [0.591]	4.685	4.055	3.268	1.220
20 mm [0.787]	4.882	4.252	3.465	1.417
25 mm [0.984]	5.079	4.449	3.661	1.614
30 mm [1.181]	5.276	4.646	3.858	1.811
35 mm [1.378]	5.472	4.843	4.055	2.008
40 mm [1.575]	5.669	5.039	4.252	2.205
45 mm [1.772]	5.866	5.236	4.449	2.402
50 mm [1.969]	6.063	5.433	4.646	2.598
55 mm [2.165]	6.260	5.630	4.843	2.795
60 mm [2.362]	6.457	5.827	5.039	2.992
70 mm [2.756]	6.850	6.220	5.433	3.386
75 mm [2.953]	7.047	6.417	5.630	3.583
80 mm [3.150]	7.244	6.614	5.827	3.780
90 mm [3.543]	7.638	7.008	6.220	4.173
100 mm [3.937]	8.031	7.402	6.614	4.567

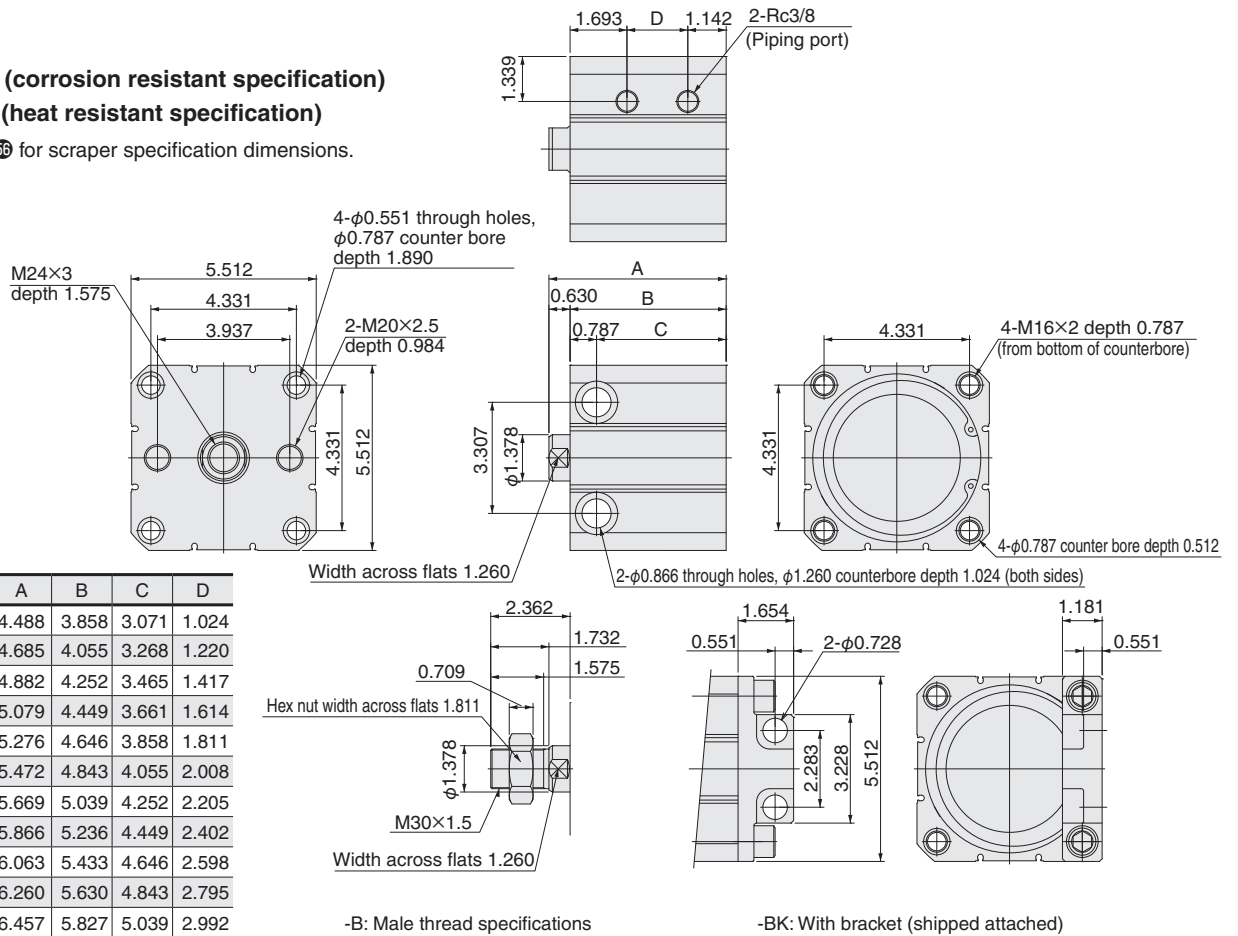

● BCY10 (scraper specification)

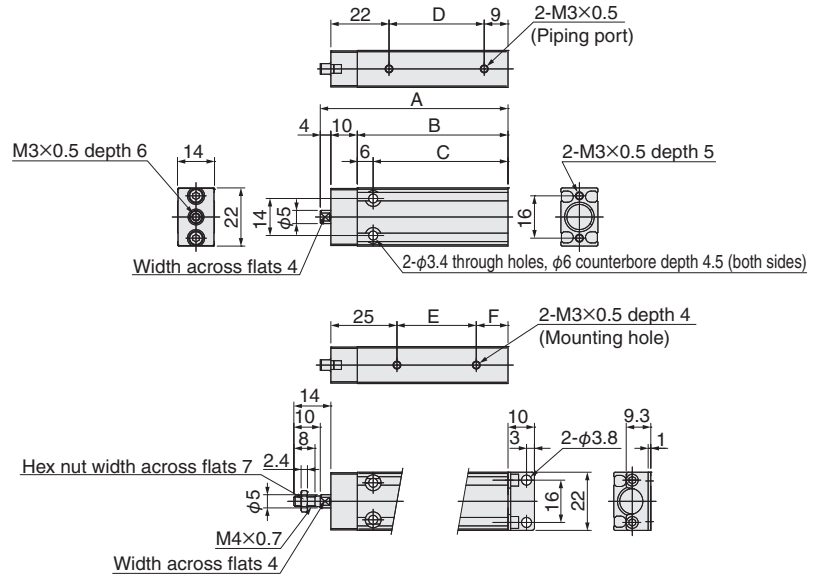

Stroke	A	B	C	D	E	F
5	46	32	26	11	8	9
10	51	37	31	16	10	12
15	56	42	36	21	10	17
20	61	47	41	26	20	12
25	66	52	46	31	20	17
30	71	57	51	36	30	12

-B: Male thread specifications -BK: With bracket (shipped attached)

Note: This product cannot use reed switch type sensor switches.

● BCY12 (scraper specification)

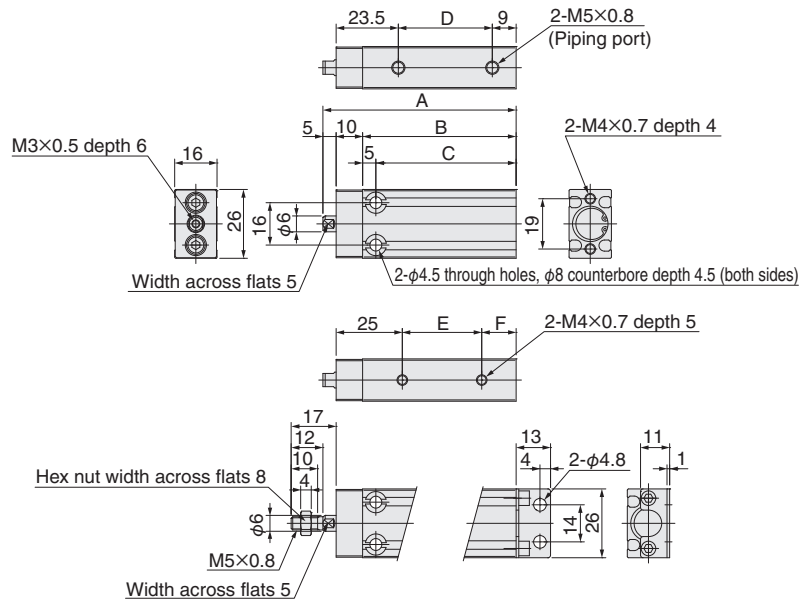

Stroke	A	B	C	D	E	F
5	48	33	28	10.5	8	10
10	53	38	33	15.5	10	13
15	58	43	38	20.5	10	18
20	63	48	43	25.5	20	13
25	68	53	48	30.5	20	18
30	73	58	53	35.5	30	13
35	78	63	58	40.5	30	18
40	83	68	63	45.5	40	13
45	88	73	68	50.5	40	18
50	93	78	73	55.5	50	13

-B: Male thread specifications -BK: With bracket (shipped attached)

Note: This product cannot use reed switch type sensor switches.

● BCY10 (scraper specification)

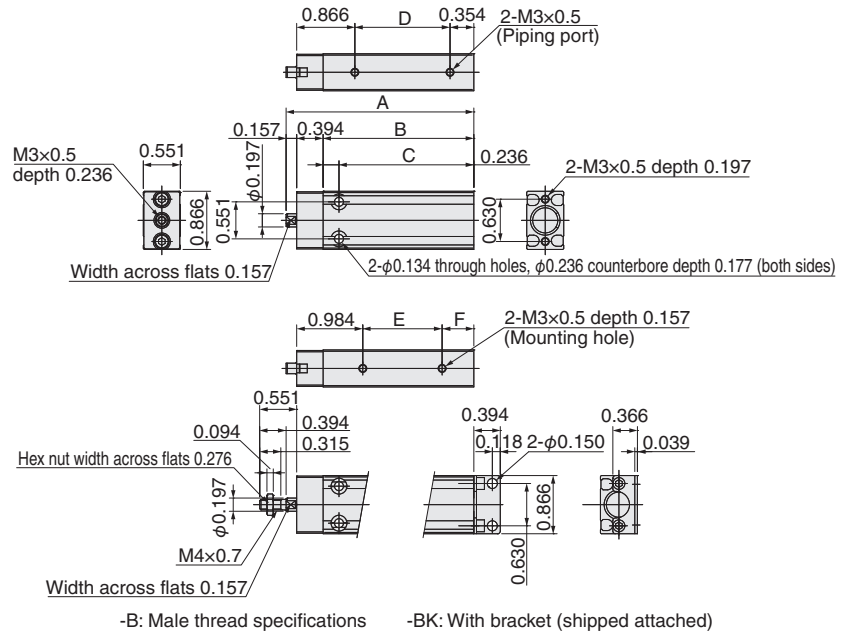

Stroke	A	B	C	D	E	F
5 mm [0.197]	1.811	1.260	1.024	0.433	0.315	0.354
10 mm [0.394]	2.008	1.457	1.220	0.630	0.394	0.472
15 mm [0.591]	2.205	1.654	1.417	0.827	0.394	0.669
20 mm [0.787]	2.402	1.850	1.614	1.024	0.787	0.472
25 mm [0.984]	2.598	2.047	1.811	1.220	0.787	0.669
30 mm [1.181]	2.795	2.244	2.008	1.417	1.181	0.472

Note: This product cannot use reed switch type sensor switches.

● BCY12 (scraper specification)

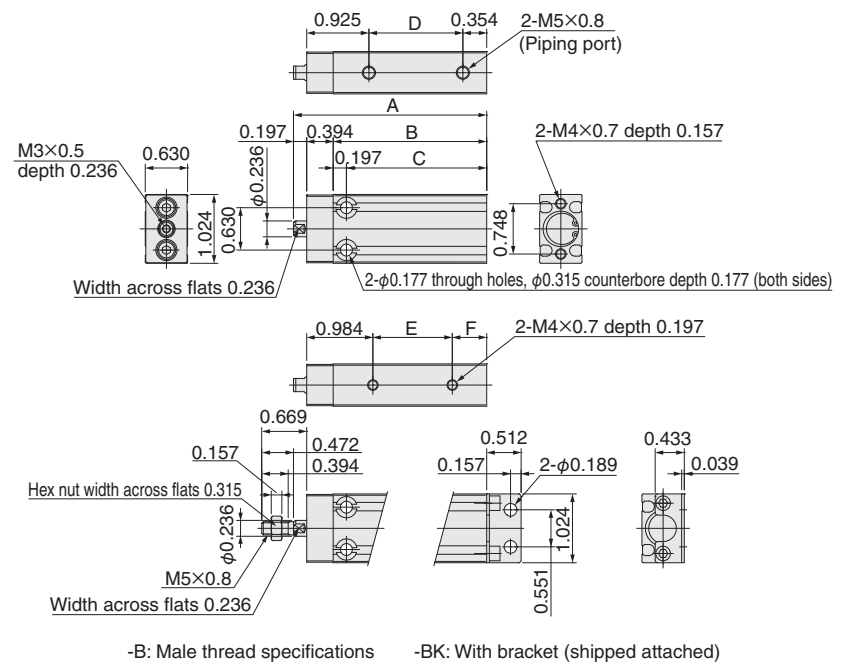

Stroke	A	B	C	D	E	F
5 mm [0.197]	1.890	1.299	1.102	0.413	0.315	0.394
10 mm [0.394]	2.087	1.496	1.299	0.610	0.394	0.512
15 mm [0.591]	2.283	1.693	1.496	0.807	0.394	0.709
20 mm [0.787]	2.480	1.890	1.693	1.004	0.787	0.512
25 mm [0.984]	2.677	2.087	1.890	1.201	0.787	0.709
30 mm [1.181]	2.874	2.283	2.087	1.398	1.181	0.512
35 mm [1.378]	3.071	2.480	2.283	1.594	1.181	0.709
40 mm [1.575]	3.268	2.677	2.480	1.791	1.575	0.512
45 mm [1.772]	3.465	2.874	2.677	1.988	1.575	0.709
50 mm [1.969]	3.661	3.071	2.874	2.185	1.969	0.512

Note: This product cannot use reed switch type sensor switches.

● BCY16 (scraper specification)

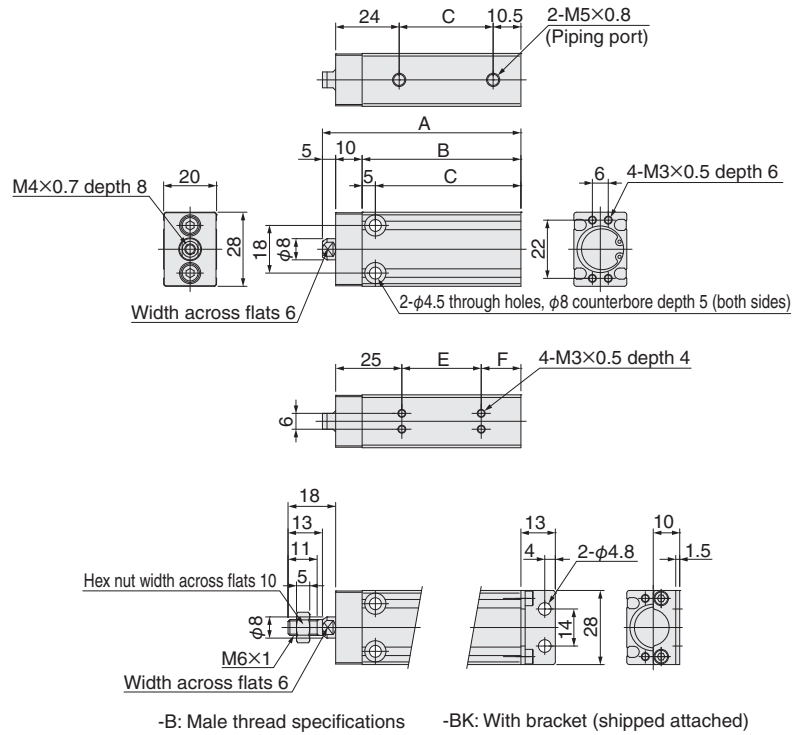

Stroke	A	B	C	D	E	F
5	50	35	30	10.5	10	10
10	55	40	35	15.5	10	15
15	60	45	40	20.5	10	20
20	65	50	45	25.5	20	15
25	70	55	50	30.5	20	20
30	75	60	55	35.5	30	15
35	80	65	60	40.5	30	20
40	85	70	65	45.5	40	15
45	90	75	70	50.5	40	20
50	95	80	75	55.5	50	15

● BCY20 (scraper specification)

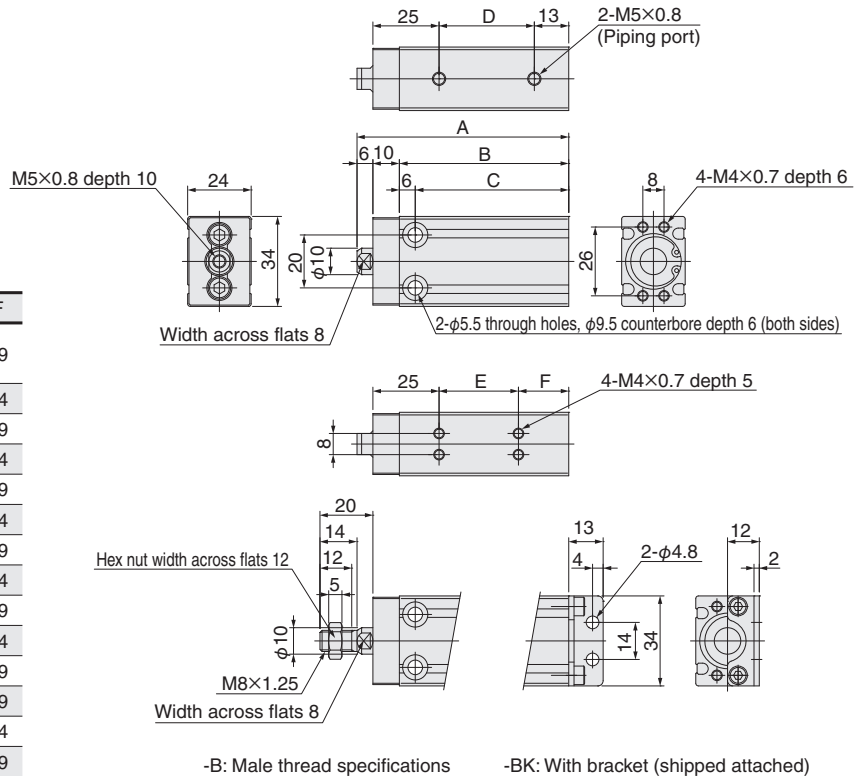

Stroke	A	B	C	D	E	F
5	60	44	38	16	10	19
10	65	49	43	21	10	24
15	70	54	48	26	20	19
20	75	59	53	31	20	24
25	80	64	58	36	30	19
30	85	69	63	41	30	24
35	90	74	68	46	40	19
40	95	79	73	51	40	24
45	100	84	78	56	50	19
50	105	89	83	61	50	24
55	110	94	88	66	50	29
60	115	99	93	71	60	19
65	120	104	98	76	70	19
70	125	109	103	81	70	24
75	130	114	108	86	70	29
80	135	119	113	91	80	19
85	140	124	118	96	90	19
90	145	129	123	101	90	24
95	150	134	128	106	90	29

Note: 5 stroke supports collar stopper.

● BCY16 (scraper specification)

Stroke	A	B	C	D	E	F
5 mm [0.197]	1.969	1.378	1.181	0.413	0.394	0.394
10 mm [0.394]	2.165	1.575	1.378	0.610	0.394	0.591
15 mm [0.591]	2.362	1.772	1.575	0.807	0.394	0.787
20 mm [0.787]	2.559	1.969	1.772	1.004	0.787	0.591
25 mm [0.984]	2.756	2.165	1.969	1.201	0.787	0.787
30 mm [1.181]	2.953	2.362	2.165	1.398	1.181	0.591
35 mm [1.378]	3.150	2.559	2.362	1.594	1.181	0.787
40 mm [1.575]	3.346	2.756	2.559	1.791	1.575	0.591
45 mm [1.772]	3.543	2.953	2.756	1.988	1.575	0.787
50 mm [1.969]	3.740	3.150	2.953	2.185	1.969	0.591

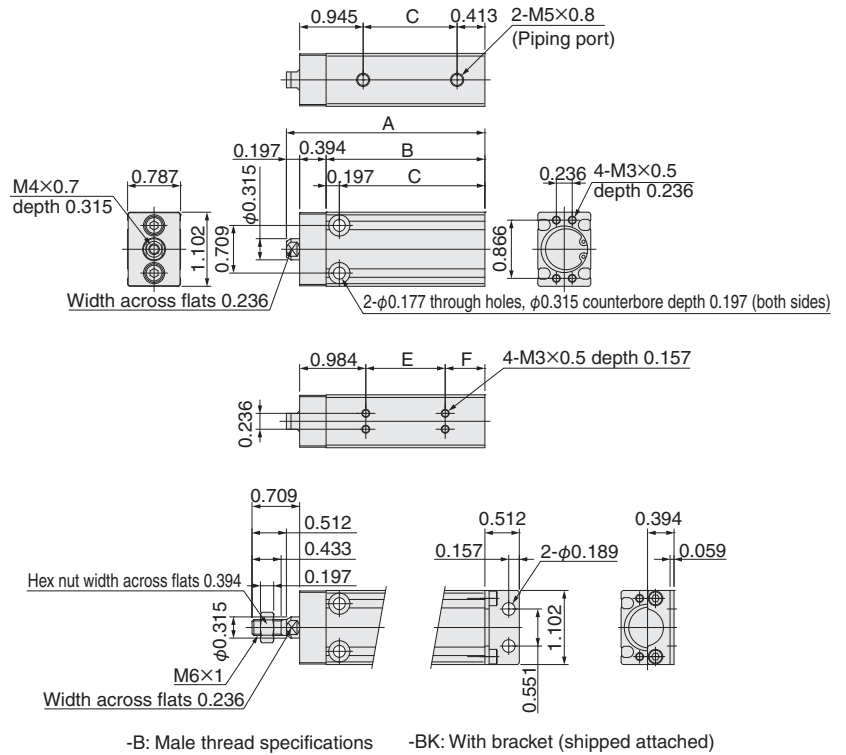

● BCY20 (scraper specification)

Stroke	A	B	C	D	E	F
5 mm [0.197]	2.362	1.732	1.496	0.630	0.394	0.748
10 mm [0.394]	2.559	1.929	1.693	0.827	0.394	0.945
15 mm [0.591]	2.756	2.126	1.890	1.024	0.787	0.748
20 mm [0.787]	2.953	2.323	2.087	1.220	0.787	0.945
25 mm [0.984]	3.150	2.520	2.283	1.417	1.181	0.748
30 mm [1.181]	3.346	2.717	2.480	1.614	1.181	0.945
35 mm [1.378]	3.543	2.913	2.677	1.811	1.575	0.748
40 mm [1.575]	3.740	3.110	2.874	2.008	1.575	0.945
45 mm [1.772]	3.937	3.307	3.071	2.205	1.969	0.748
50 mm [1.969]	4.134	3.504	3.268	2.402	1.969	0.945
55 mm [2.165]	4.331	3.701	3.465	2.598	1.969	1.142
60 mm [2.362]	4.724	4.094	3.858	2.992	2.756	0.748
70 mm [2.953]	4.921	4.291	4.055	3.189	2.756	0.945
80 mm [3.150]	5.118	4.488	4.252	3.386	2.756	1.142
90 mm [3.543]	5.512	4.882	4.646	3.780	3.543	0.748
100 mm [3.937]	5.906	5.276	5.039	4.173	3.543	1.142

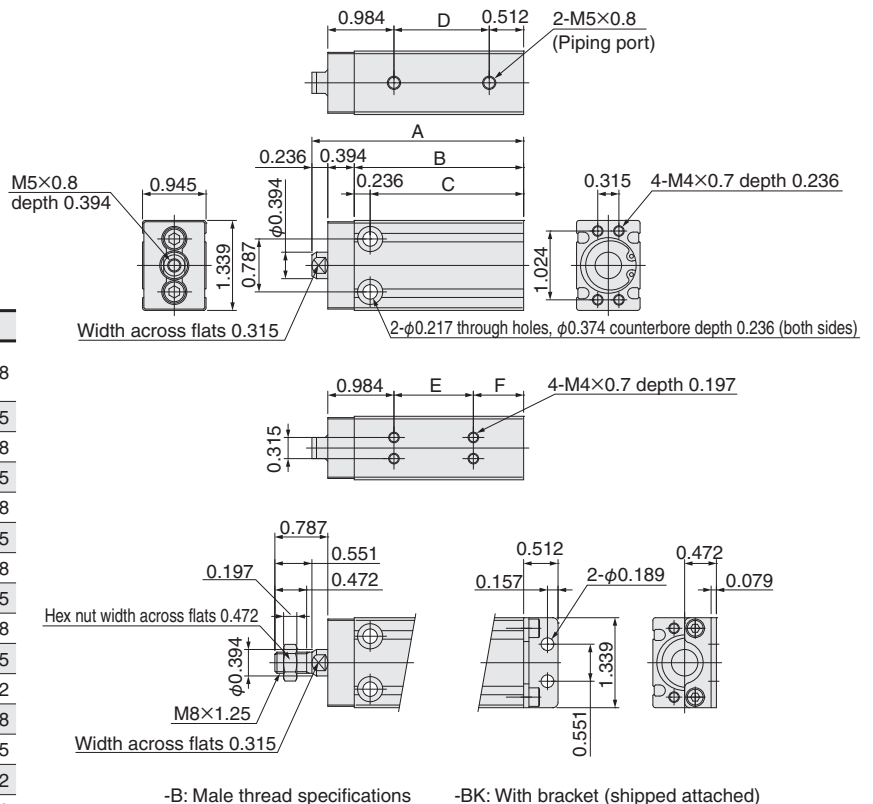

Note: 0.197 stroke supports collar stopper.

● BCY25 (scraper specification)

Stroke	A	B	C	D	E	F
5						
10	62	46	40	17	10	21
15	67	51	45	22	10	26
20	72	56	50	27	20	21
25	77	61	55	32	20	26
30	82	66	60	37	30	21
35	87	71	65	42	30	26
40	92	76	70	47	40	21
45	97	81	75	52	40	26
50	102	86	80	57	50	21
55	107	91	85	62	50	26
60	112	96	90	67	50	31
70	122	106	100	77	70	21
75	127	111	105	82	70	26
80	132	116	110	87	70	31
90	142	126	120	97	90	21
100	152	136	130	107	90	31

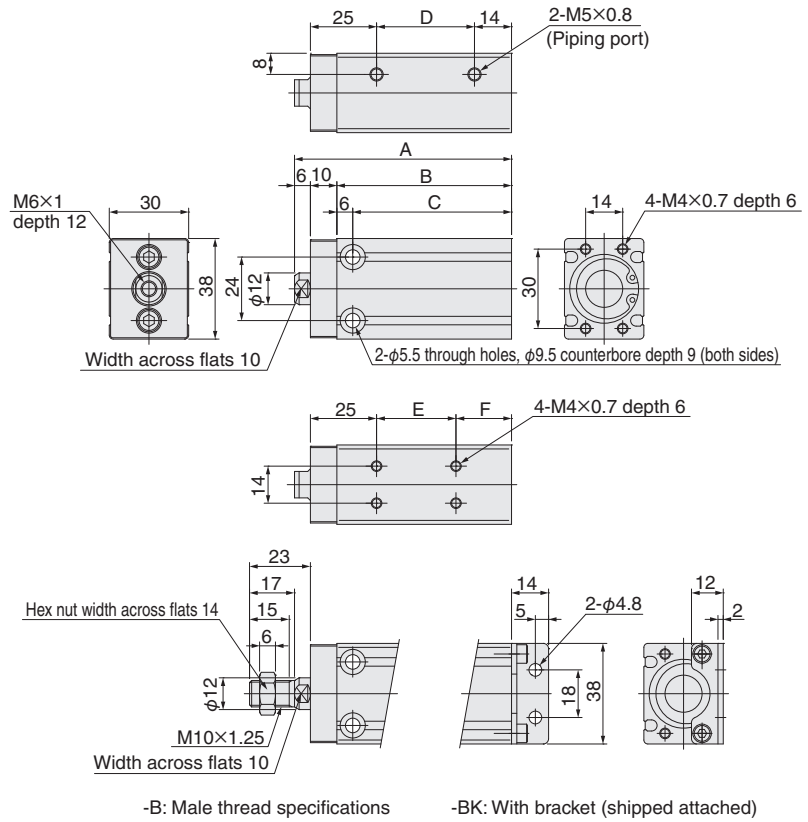

Note: 5 stroke supports collar stopper.

● BCY32 (scraper specification)

Stroke	A	B	C	D	E	F
10	72	50	43	16	10	20
15	77	55	48	21	10	25
20	82	60	53	26	20	20
25	87	65	58	31	20	25
30	92	70	63	36	30	20
35	97	75	68	41	30	25
40	102	80	73	46	40	20
45	107	85	78	51	40	25
50	112	90	83	56	50	20
55	117	95	88	61	50	25
60	122	100	93	66	50	30
70	132	110	103	76	70	20
75	137	115	108	81	70	25
80	142	120	113	86	80	20
90	152	130	123	96	80	30
100	162	140	133	106	100	20

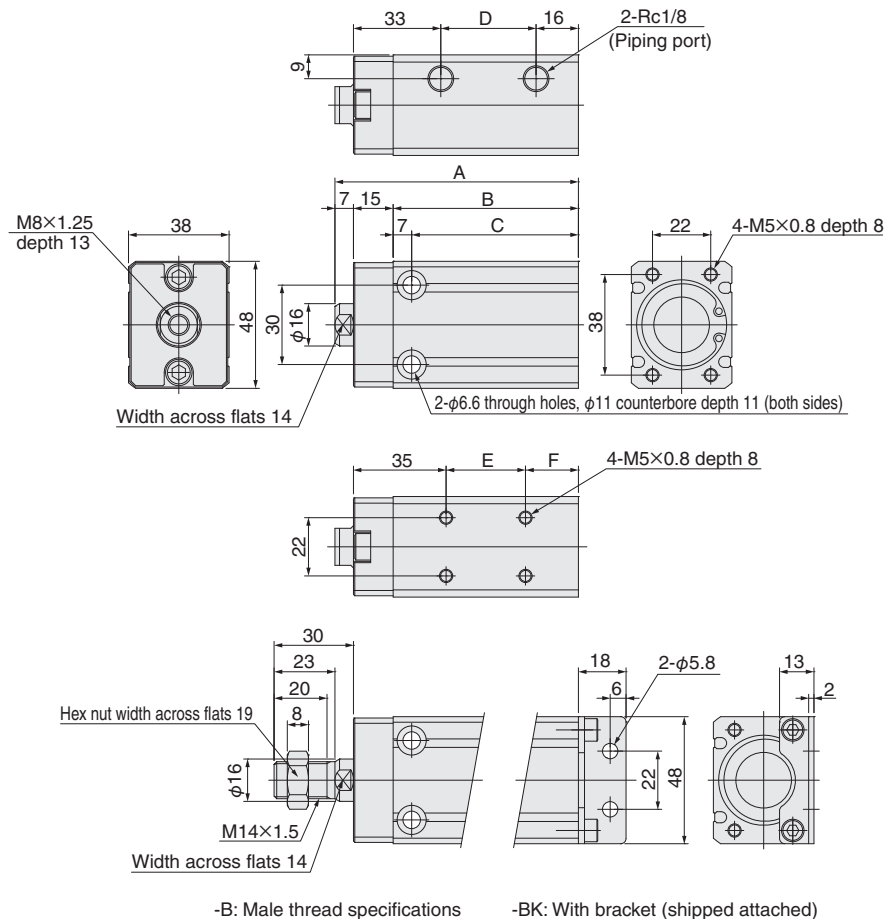

● BCY25 (scraper specification)

Stroke	A	B	C	D	E	F
5 mm [0.197]	2.441	1.811	1.575	0.669	0.394	0.827
10 mm [0.394]	2.441	1.811	1.575	0.669	0.394	0.827
15 mm [0.591]	2.638	2.008	1.772	0.866	0.394	1.024
20 mm [0.787]	2.835	2.205	1.969	1.063	0.787	0.827
25 mm [0.984]	3.031	2.402	2.165	1.260	0.787	1.024
30 mm [1.181]	3.228	2.598	2.362	1.457	1.181	0.827
35 mm [1.378]	3.425	2.795	2.559	1.654	1.181	1.024
40 mm [1.575]	3.622	2.992	2.756	1.850	1.575	0.827
45 mm [1.772]	3.819	3.189	2.953	2.047	1.575	1.024
50 mm [1.969]	4.016	3.386	3.150	2.244	1.969	0.827
55 mm [2.165]	4.213	3.583	3.346	2.441	1.969	1.024
60 mm [2.362]	4.409	3.780	3.543	2.638	1.969	1.220
70 mm [2.756]	4.803	4.173	3.937	3.031	2.756	0.827
75 mm [2.953]	5.000	4.370	4.134	3.228	2.756	1.024
80 mm [3.150]	5.197	4.567	4.331	3.425	2.756	1.220
90 mm [3.543]	5.591	4.961	4.724	3.819	3.543	0.827
100 mm [3.937]	5.984	5.354	5.118	4.213	3.543	1.220

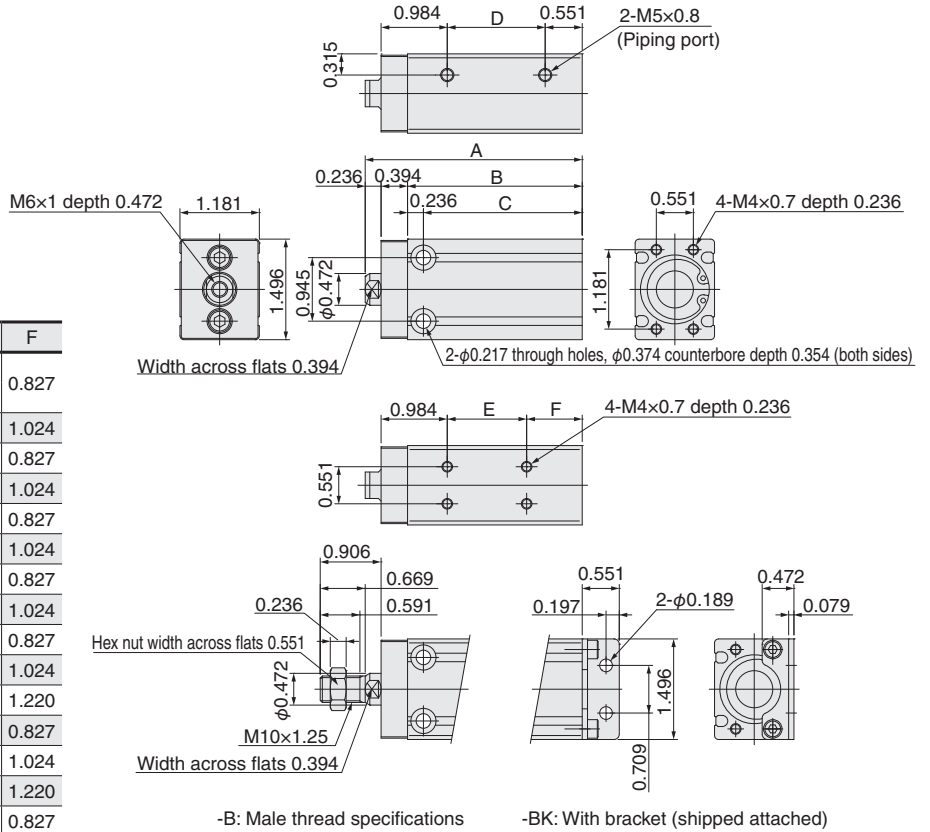

-B: Male thread specifications -BK: With bracket (shipped attached)

Note: 0.197 stroke supports collar stopper.

● BCY32 (scraper specification)

Stroke	A	B	C	D	E	F
10 mm [0.394]	2.835	1.969	1.693	0.630	0.394	0.787
15 mm [0.591]	3.031	2.165	1.890	0.827	0.394	0.984
20 mm [0.787]	3.228	2.362	2.087	1.024	0.787	0.787
25 mm [0.984]	3.425	2.559	2.283	1.220	0.787	0.984
30 mm [1.181]	3.622	2.756	2.480	1.417	1.181	0.787
35 mm [1.378]	3.819	2.953	2.677	1.614	1.181	0.984
40 mm [1.575]	4.016	3.150	2.874	1.811	1.575	0.787
45 mm [1.772]	4.213	3.346	3.071	2.008	1.575	0.984
50 mm [1.969]	4.409	3.543	3.268	2.205	1.969	0.787
55 mm [2.165]	4.606	3.740	3.465	2.402	1.969	0.984
60 mm [2.362]	4.803	3.937	3.661	2.598	1.969	1.181
70 mm [2.756]	5.197	4.331	4.055	2.992	2.756	0.787
75 mm [2.953]	5.394	4.528	4.252	3.189	2.756	0.984
80 mm [3.150]	5.591	4.724	4.449	3.386	3.150	0.787
90 mm [3.543]	5.984	5.118	4.843	3.780	3.150	1.181
100 mm [3.937]	6.378	5.512	5.236	4.173	3.937	0.787

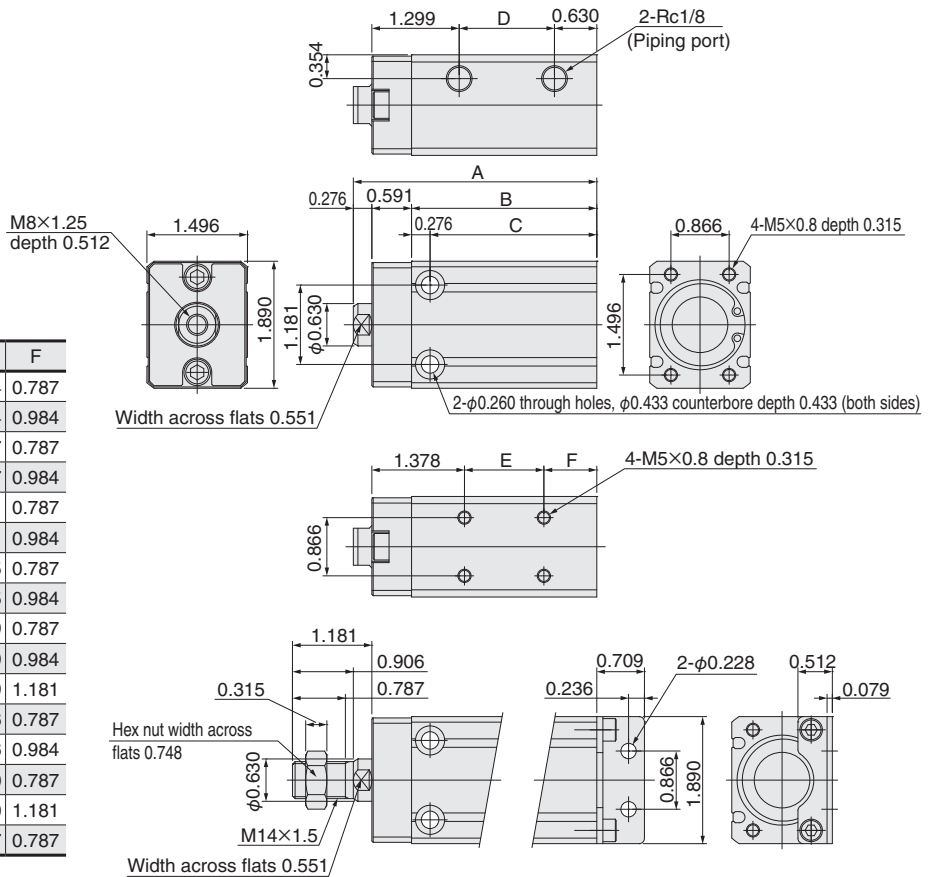

-B: Male thread specifications -BK: With bracket (shipped attached)

● BCY40 (scraper specification)

Stroke	A	B	C	D	E	F
10	79	57	48	17	15	27
15	84	62	53	22	15	32
20	89	67	58	27	20	27
25	94	72	63	32	20	32
30	99	77	68	37	30	27
35	104	82	73	42	30	32
40	109	87	78	47	40	27
45	114	92	83	52	40	32
50	119	97	88	57	50	27
55	124	102	93	62	50	32
60	129	107	98	67	60	27
70	139	117	108	77	70	27
75	144	122	113	82	70	32
80	149	127	118	87	80	27
90	159	137	128	97	80	37
100	169	147	138	107	100	27

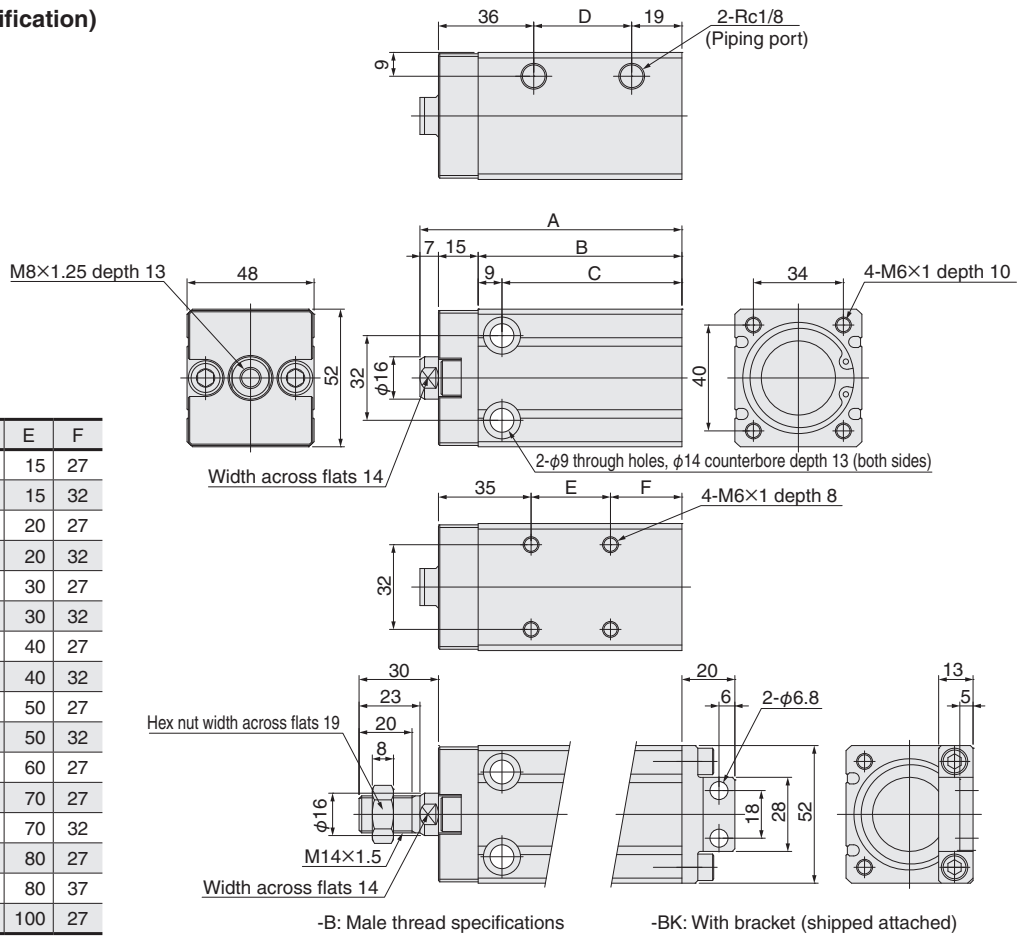

● BCY50 (scraper specification)

Stroke	A	B	C	D
10	86	63	52	18
15	91	68	57	23
20	96	73	62	28
25	101	78	67	33
30	106	83	72	38
35	111	88	77	43
40	116	93	82	48
45	121	98	87	53
50	126	103	92	58
55	131	108	97	63
60	136	113	102	68
70	146	123	112	78
75	151	128	117	83
80	156	133	122	88
90	166	143	132	98
100	176	153	142	108

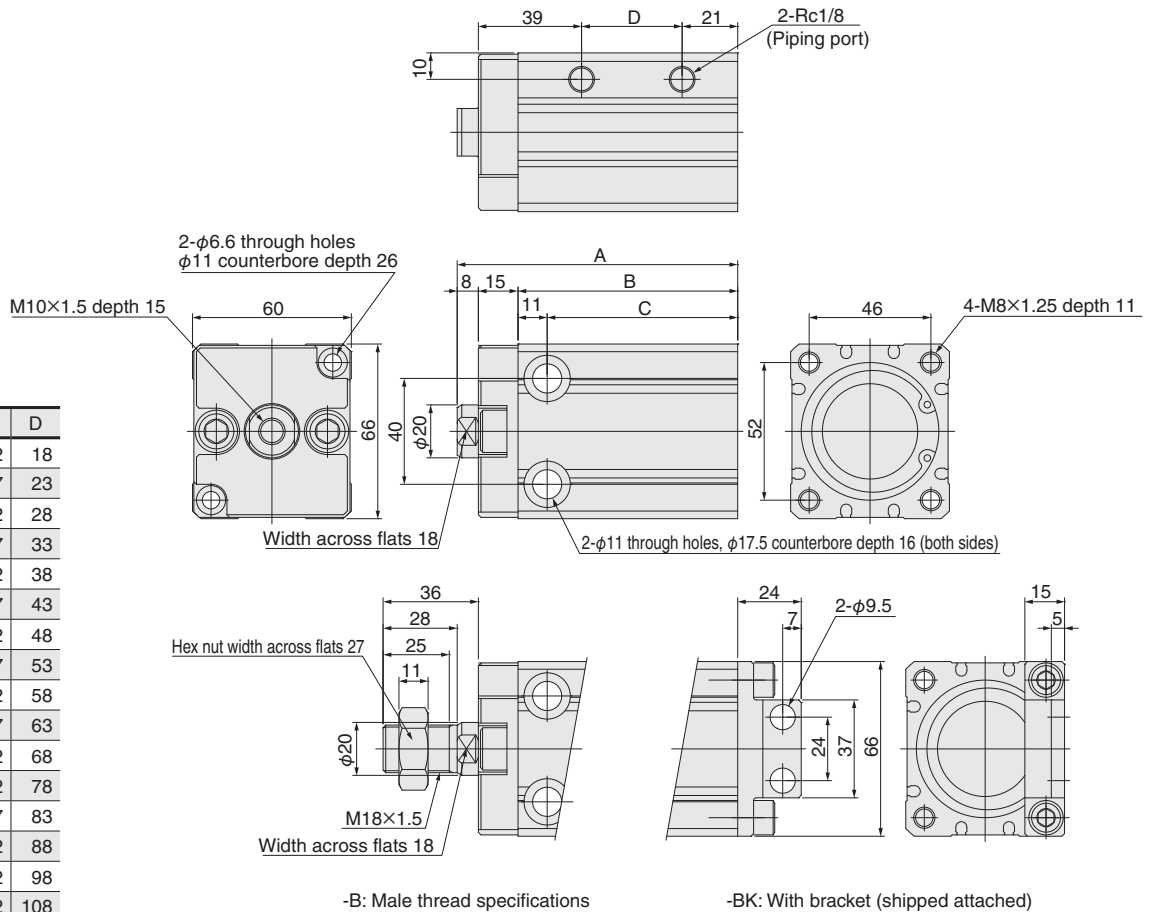

● BCY40 (scraper specification)

Stroke	A	B	C	D	E	F
10 mm [0.394]	3.110	2.244	1.890	0.669	0.591	1.063
15 mm [0.591]	3.307	2.441	2.087	0.866	0.591	1.260
20 mm [0.787]	3.504	2.638	2.283	1.063	0.787	1.063
25 mm [0.984]	3.701	2.835	2.480	1.260	0.787	1.260
30 mm [1.181]	3.898	3.031	2.677	1.457	1.181	1.063
35 mm [1.378]	4.094	3.228	2.874	1.654	1.181	1.260
40 mm [1.575]	4.291	3.425	3.071	1.850	1.575	1.063
45 mm [1.772]	4.488	3.622	3.268	2.047	1.575	1.260
50 mm [1.969]	4.685	3.819	3.465	2.244	1.969	1.063
55 mm [2.165]	4.882	4.016	3.661	2.441	1.969	1.260
60 mm [2.362]	5.079	4.213	3.858	2.638	2.362	1.063
70 mm [2.756]	5.472	4.606	4.252	3.031	2.756	1.063
75 mm [2.953]	5.669	4.803	4.449	3.228	2.756	1.260
80 mm [3.150]	5.866	5.000	4.646	3.425	3.150	1.063
90 mm [3.543]	6.260	5.394	5.039	3.819	3.150	1.457
100 mm [3.937]	6.654	5.787	5.433	4.213	3.937	1.063

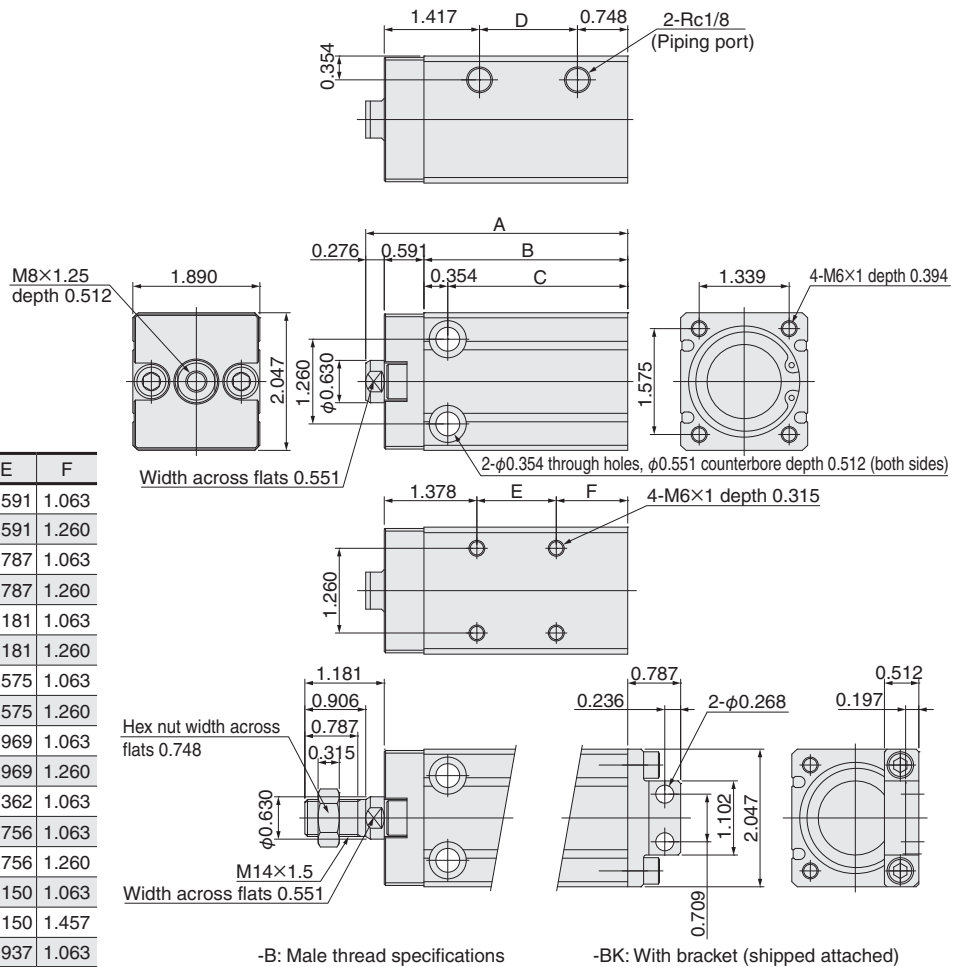

● BCY50 (scraper specification)

Stroke	A	B	C	D
10 mm [0.394]	3.386	2.480	2.047	0.709
15 mm [0.591]	3.583	2.677	2.244	0.906
20 mm [0.787]	3.780	2.874	2.441	1.102
25 mm [0.984]	3.976	3.071	2.638	1.299
30 mm [1.181]	4.173	3.268	2.835	1.496
35 mm [1.378]	4.370	3.465	3.031	1.693
40 mm [1.575]	4.567	3.661	3.228	1.890
45 mm [1.772]	4.764	3.858	3.425	2.087
50 mm [1.969]	4.961	4.055	3.622	2.283
55 mm [2.165]	5.157	4.252	3.819	2.480
60 mm [2.362]	5.354	4.449	4.016	2.677
70 mm [2.756]	5.748	4.843	4.409	3.071
75 mm [2.953]	5.945	5.039	4.606	3.268
80 mm [3.150]	6.142	5.236	4.803	3.465
90 mm [3.543]	6.535	5.630	5.197	3.858
100 mm [3.937]	6.929	6.024	5.591	4.252

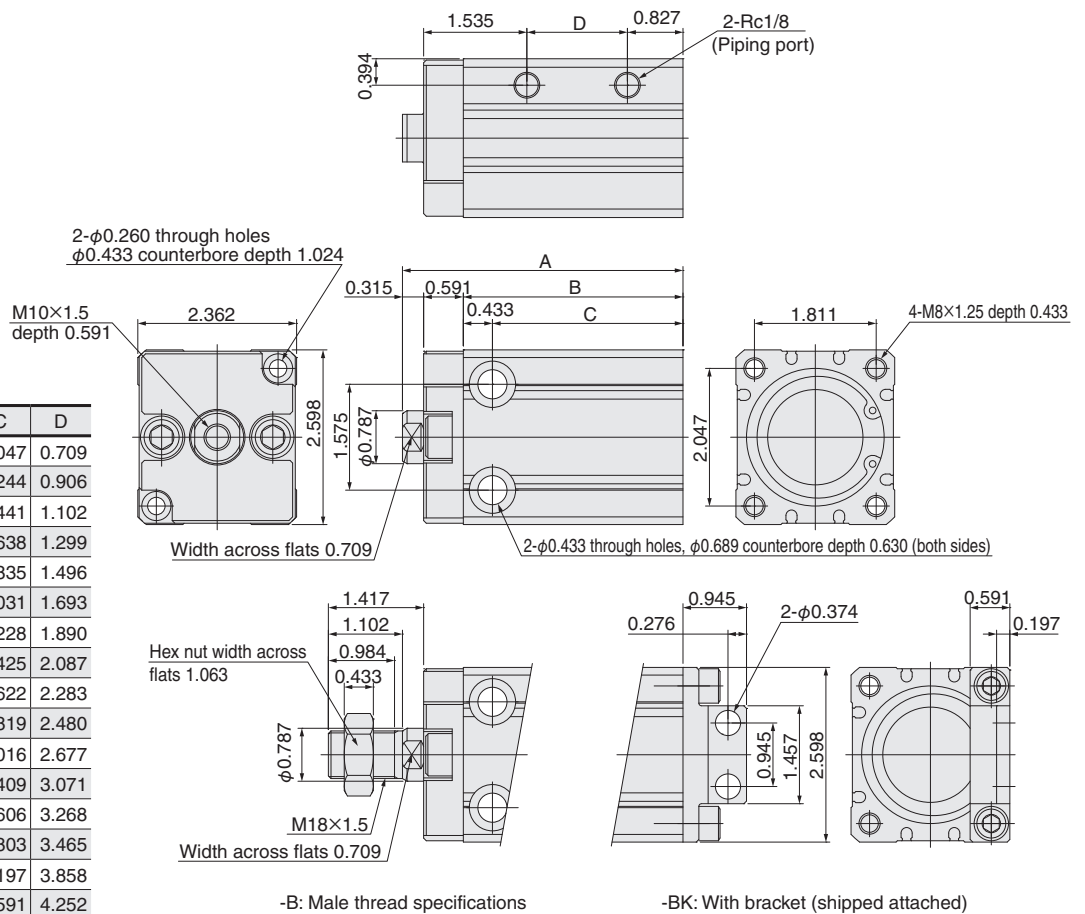

● BCY63 (scraper specification)

Stroke	A	B	C	D
10	99	71	59	21
15	104	76	64	26
20	109	81	69	31
25	114	86	74	36
30	119	91	79	41
35	124	96	84	46
40	129	101	89	51
45	134	106	94	56
50	139	111	99	61
55	144	116	104	66
60	149	121	109	71
70	159	131	119	81
75	164	136	124	86
80	169	141	129	91
90	179	151	139	101
100	189	161	149	111

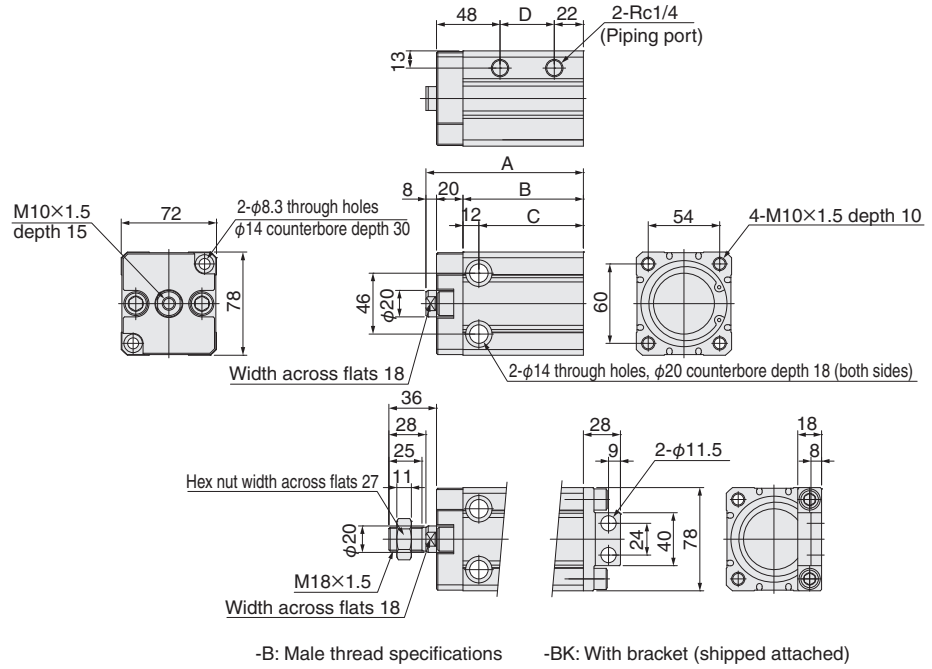

● BCY80 (scraper specification)

Stroke	A	B	C	D
10	104	74	62	24
15	109	79	67	29
20	114	84	72	34
25	119	89	77	39
30	124	94	82	44
35	129	99	87	49
40	134	104	92	54
45	139	109	97	59
50	144	114	102	64
55	149	119	107	69
60	154	124	112	74
70	164	134	122	84
75	169	139	127	89
80	174	144	132	94
90	184	154	142	104
100	194	164	152	114

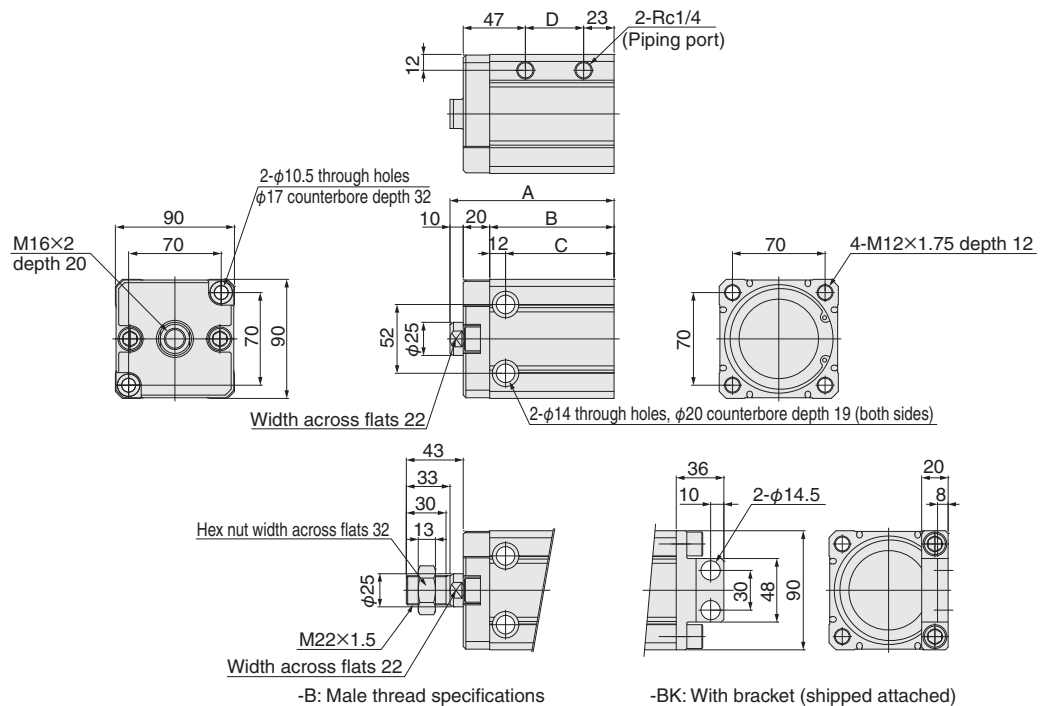

● **BCY63** (scraper specification)

Stroke	A	B	C	D
10 mm [0.394]	3.898	2.795	2.323	0.827
15 mm [0.591]	4.094	2.992	2.520	1.024
20 mm [0.787]	4.291	3.189	2.717	1.220
25 mm [0.984]	4.488	3.386	2.913	1.417
30 mm [1.181]	4.685	3.583	3.110	1.614
35 mm [1.378]	4.882	3.780	3.307	1.811
40 mm [1.575]	5.079	3.976	3.504	2.008
45 mm [1.772]	5.276	4.173	3.701	2.205
50 mm [1.969]	5.472	4.370	3.898	2.402
55 mm [2.165]	5.669	4.567	4.094	2.598
60 mm [2.362]	5.866	4.764	4.291	2.795
70 mm [2.756]	6.260	5.157	4.685	3.189
75 mm [2.953]	6.457	5.354	4.882	3.386
80 mm [3.150]	6.654	5.551	5.079	3.583
90 mm [3.543]	7.047	5.945	5.472	3.976
100 mm [3.937]	7.441	6.339	5.866	4.370

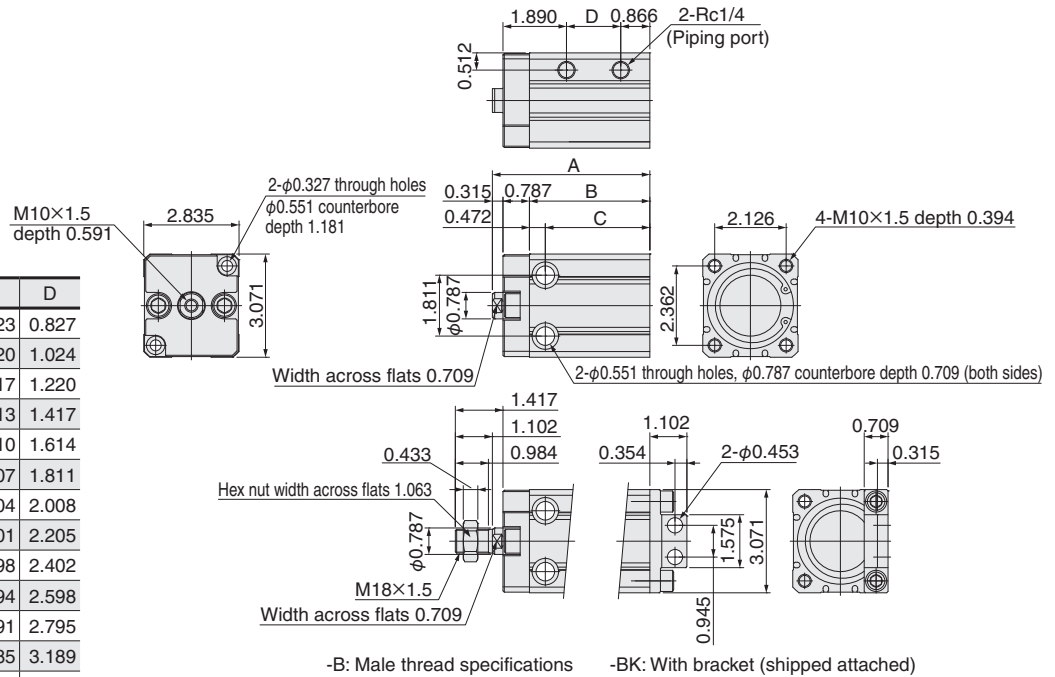

● **BCY80** (scraper specification)

Stroke	A	B	C	D
10 mm [0.394]	4.094	2.913	2.441	0.945
15 mm [0.591]	4.291	3.110	2.638	1.142
20 mm [0.787]	4.488	3.307	2.835	1.339
25 mm [0.984]	4.685	3.504	3.031	1.535
30 mm [1.181]	4.882	3.701	3.228	1.732
35 mm [1.378]	5.079	3.898	3.425	1.929
40 mm [1.575]	5.276	4.094	3.622	2.126
45 mm [1.772]	5.472	4.291	3.819	2.323
50 mm [1.969]	5.669	4.488	4.016	2.520
55 mm [2.165]	5.866	4.685	4.213	2.717
60 mm [2.362]	6.063	4.882	4.409	2.913
70 mm [2.756]	6.457	5.276	4.803	3.307
75 mm [2.953]	6.654	5.472	5.000	3.504
80 mm [3.150]	6.850	5.669	5.197	3.701
90 mm [3.543]	7.244	6.063	5.591	4.094
100 mm [3.937]	7.638	6.457	5.984	4.488

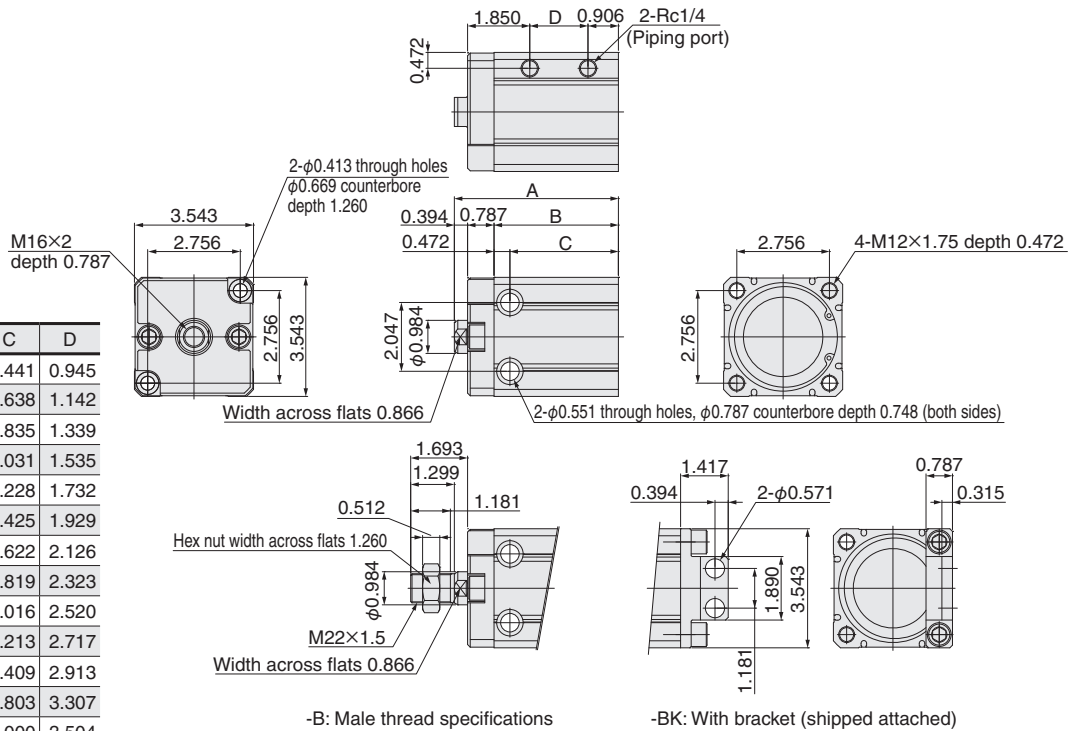

● BCY100 (scraper specification)

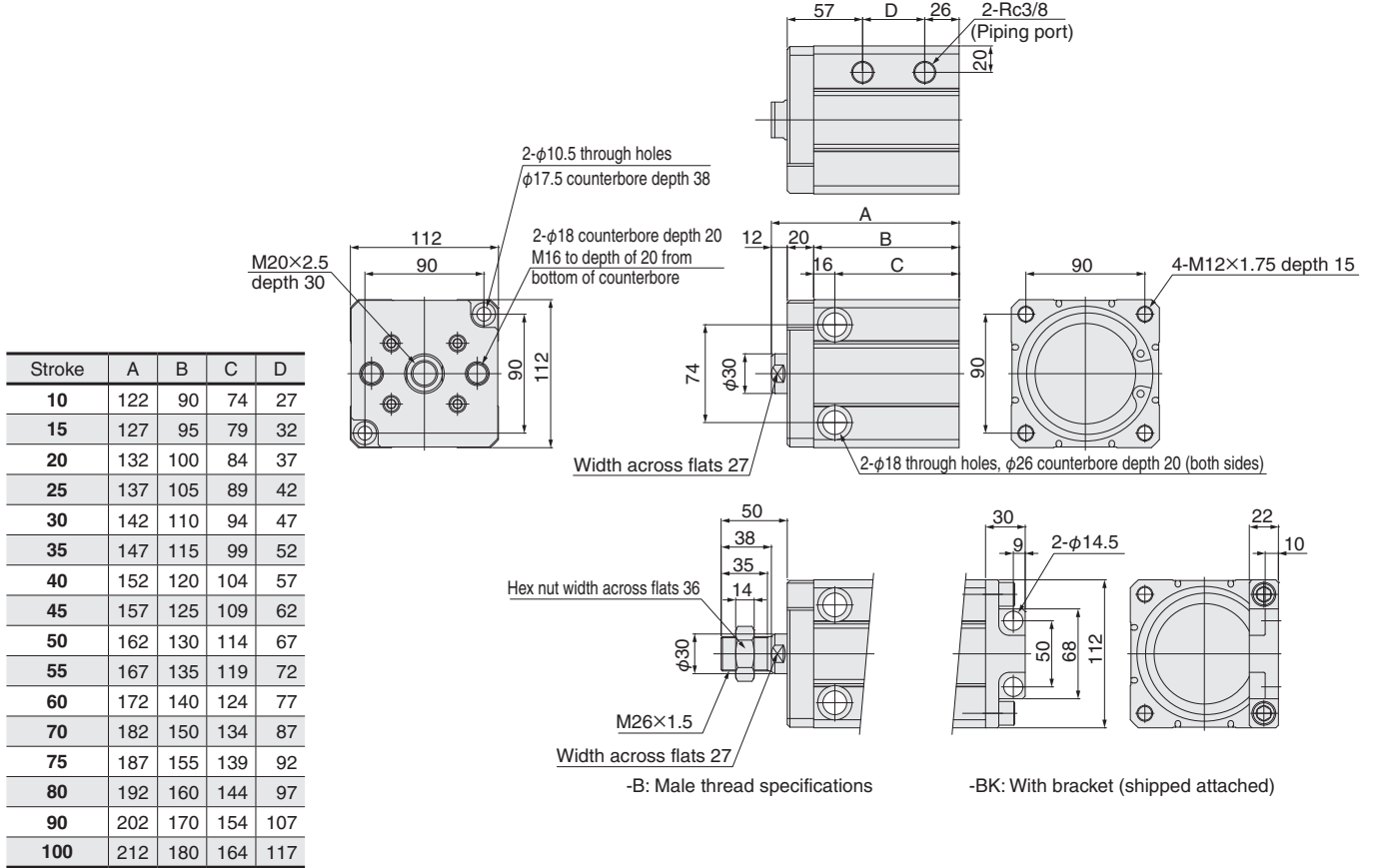

● BCY125 (scraper specification)

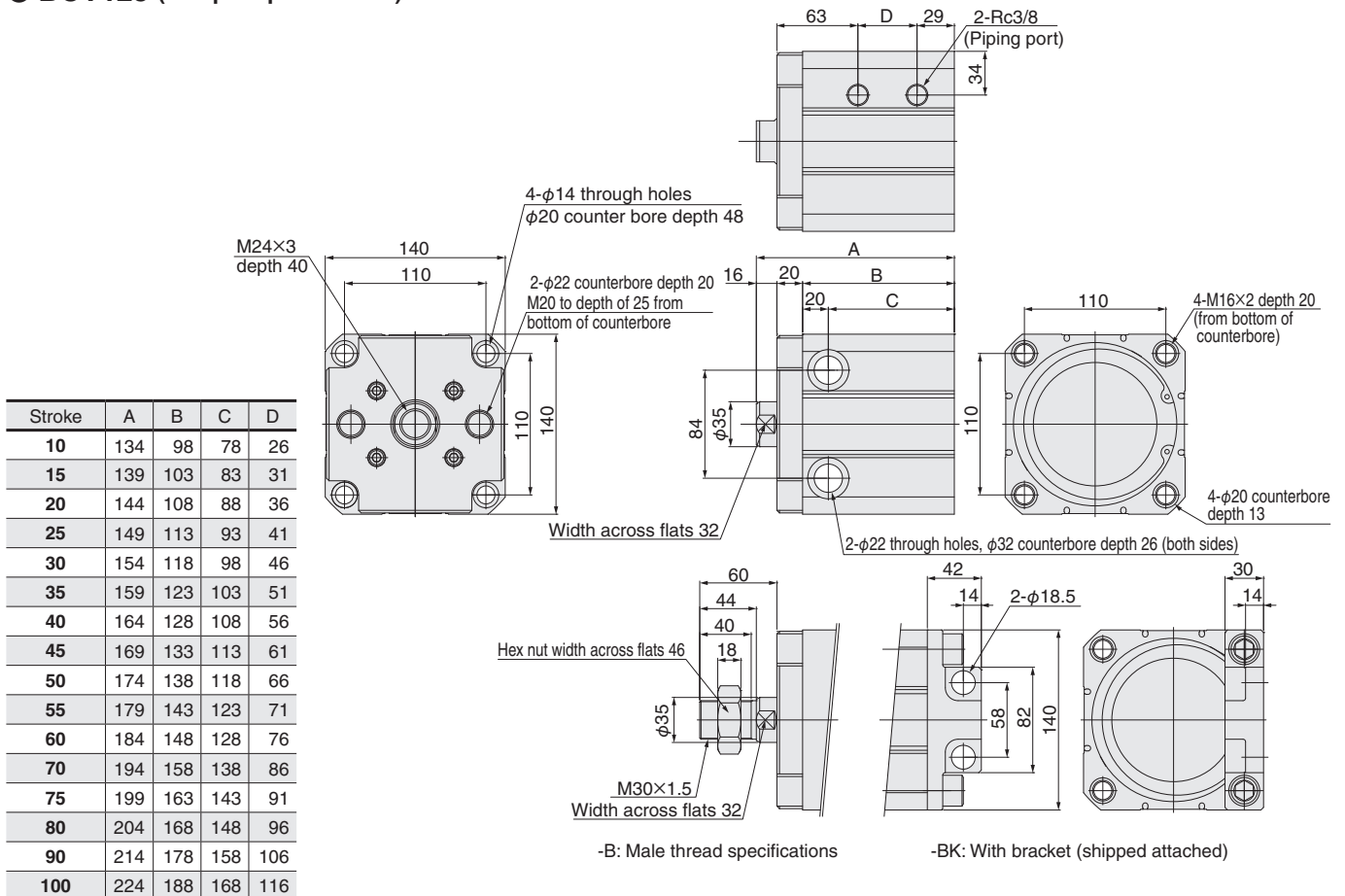

● BCY100 (scraper specification)

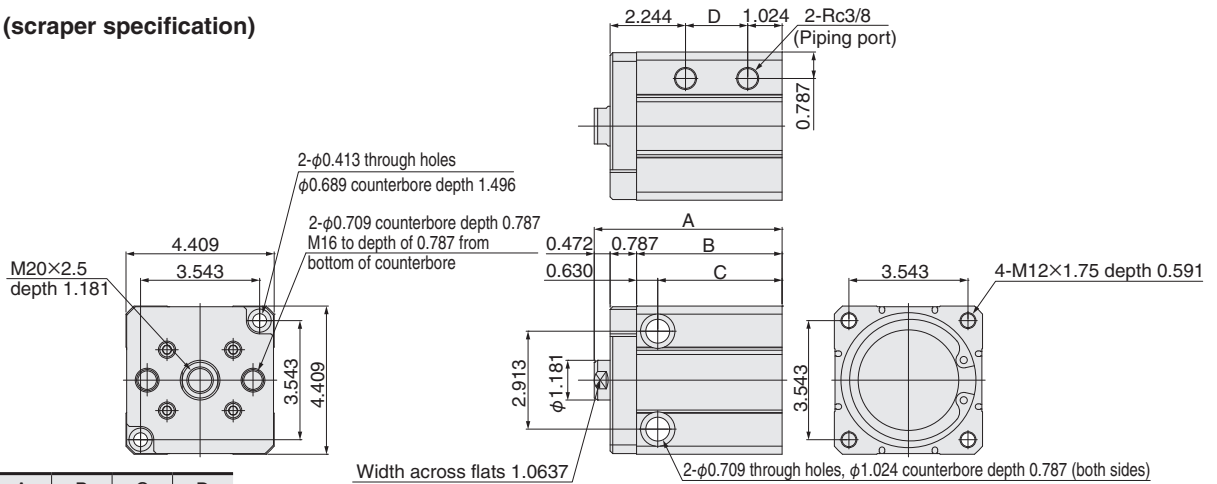

Stroke	A	B	C	D
10 mm [0.394]	4.803	3.543	2.913	1.063
15 mm [0.591]	5.000	3.740	3.110	1.260
20 mm [0.787]	5.197	3.937	3.307	1.457
25 mm [0.984]	5.394	4.134	3.504	1.654
30 mm [1.181]	5.591	4.331	3.701	1.850
35 mm [1.378]	5.787	4.528	3.898	2.047
40 mm [1.575]	5.984	4.724	4.094	2.244
45 mm [1.772]	6.181	4.921	4.291	2.441
50 mm [1.969]	6.378	5.118	4.488	2.638
55 mm [2.165]	6.575	5.315	4.685	2.835
60 mm [2.362]	6.772	5.512	4.882	3.031
70 mm [2.756]	7.165	5.906	5.276	3.425
75 mm [2.953]	7.362	6.102	5.472	3.622
80 mm [3.150]	7.559	6.299	5.669	3.819
90 mm [3.543]	7.953	6.693	6.063	4.213
100 mm [3.937]	8.346	7.087	6.457	4.606

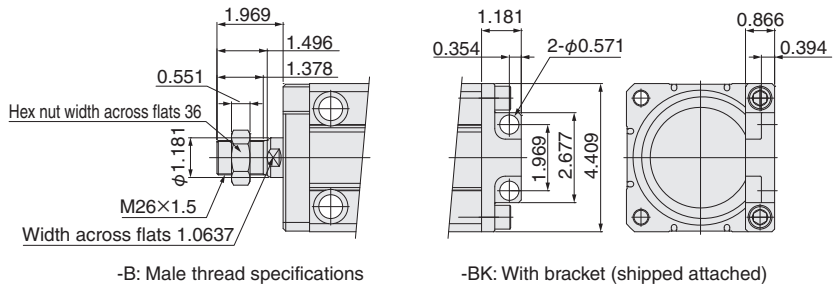

● BCY125 (scraper specification)

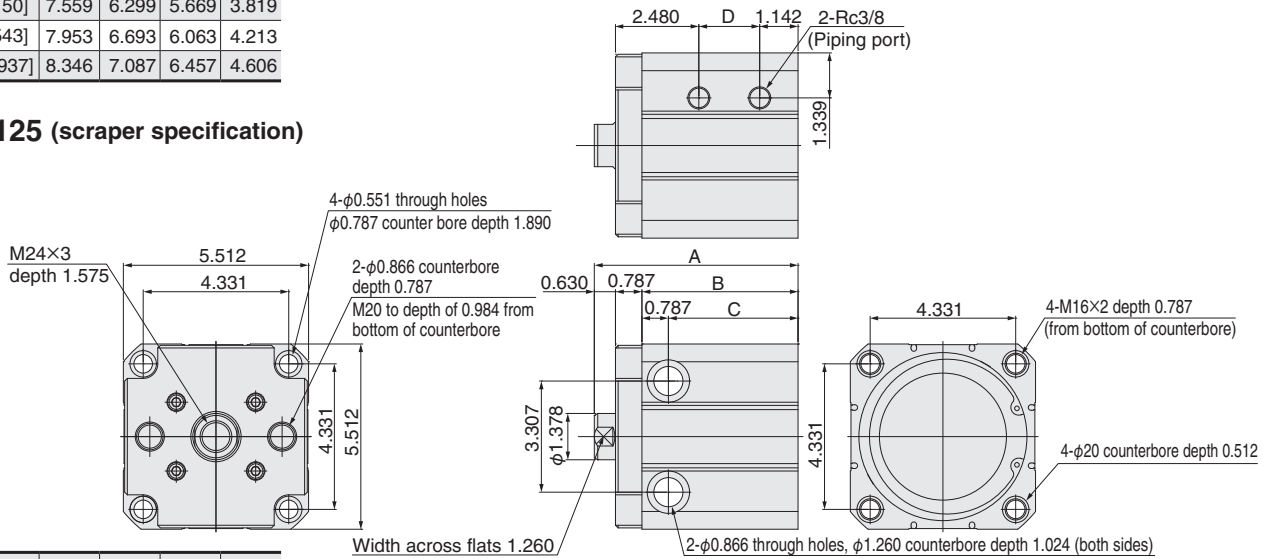

Stroke	A	B	C	D
10 mm [0.394]	5.276	3.858	3.071	1.024
15 mm [0.591]	5.472	4.055	3.268	1.220
20 mm [0.787]	5.669	4.252	3.465	1.417
25 mm [0.984]	5.866	4.449	3.661	1.614
30 mm [1.181]	6.063	4.646	3.858	1.811
35 mm [1.378]	6.260	4.843	4.055	2.008
40 mm [1.575]	6.457	5.039	4.252	2.205
45 mm [1.772]	6.654	5.236	4.449	2.402
50 mm [1.969]	6.850	5.433	4.646	2.598
55 mm [2.165]	7.047	5.630	4.843	2.795
60 mm [2.362]	7.244	5.827	5.039	2.992
70 mm [2.756]	7.638	6.220	5.433	3.386
75 mm [2.953]	7.835	6.417	5.630	3.583
80 mm [3.150]	8.031	6.614	5.827	3.780
90 mm [3.543]	8.425	7.008	6.220	4.173
100 mm [3.937]	8.819	7.402	6.614	4.567

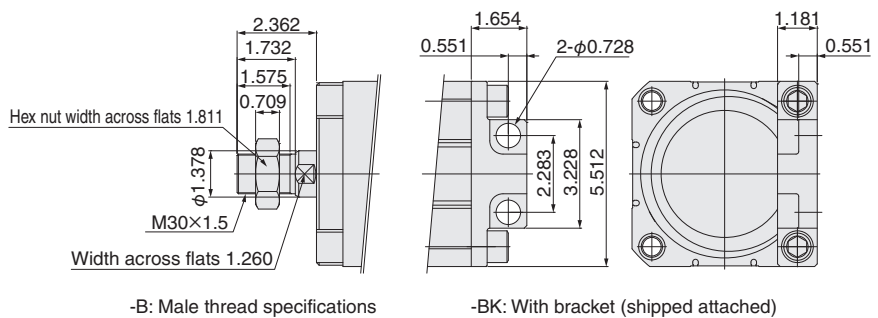

- BCSA6
- BCSAR6 (corrosion resistant specification)

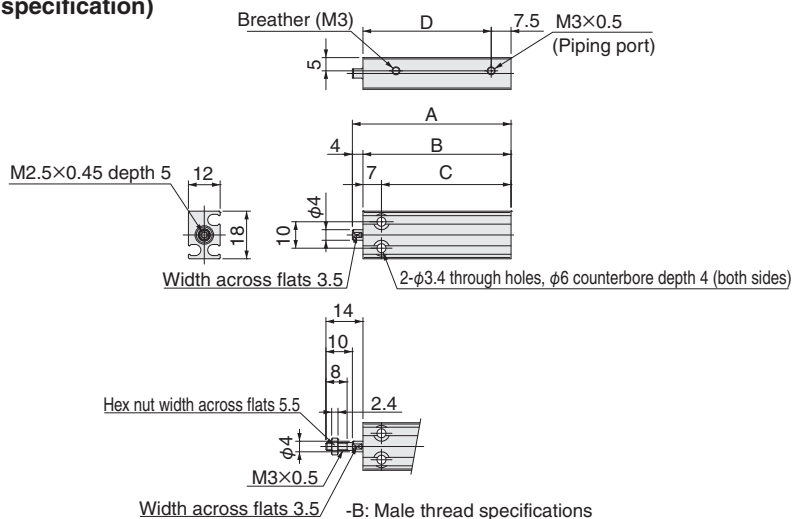

Stroke	A	B	C	D
5	50	46	39	38.5
10	55	51	44	43.5
15	60	56	49	48.5

Note: This product cannot use reed switch type sensor switches.

- BCSA8
- BCSAR8 (corrosion resistant specification)

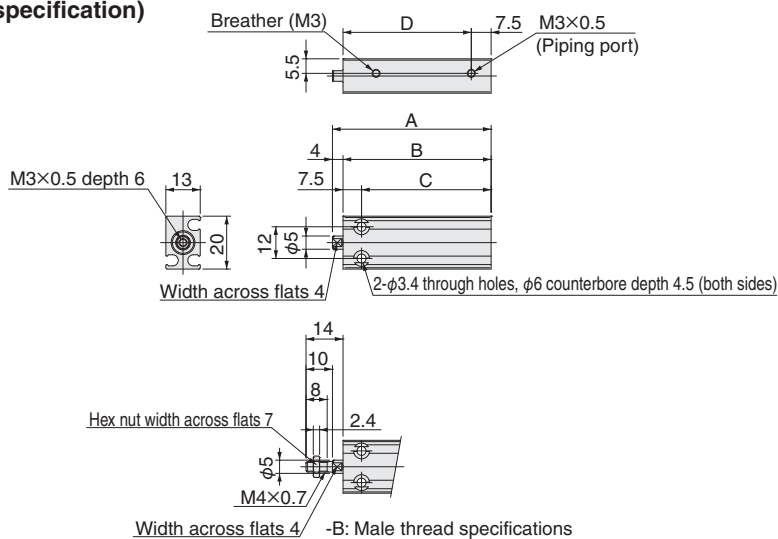

Stroke	A	B	C	D
5	50	46	38.5	38.5
10	55	51	43.5	43.5
15	60	56	48.5	48.5

Note: This product cannot use reed switch type sensor switches.

- BCSA6
- BCSAR6 (corrosion resistant specification)

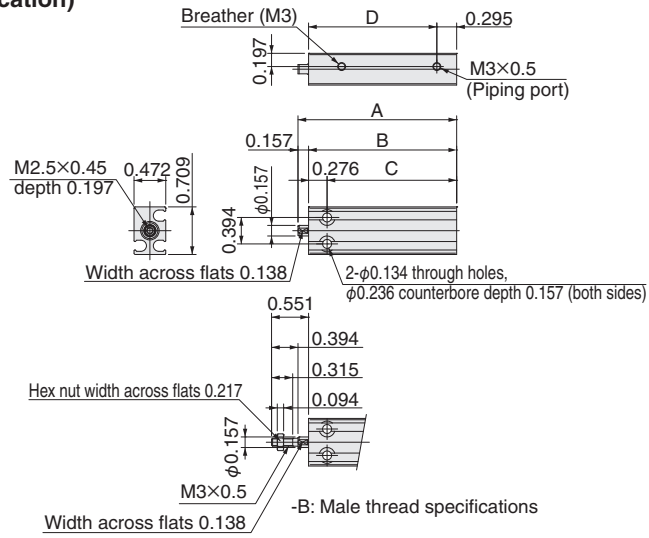

Stroke	A	B	C	D
5 mm [0.197]	1.969	1.811	1.535	1.516
10 mm [0.394]	2.165	2.008	1.732	1.713
15 mm [0.591]	2.362	2.205	1.929	1.909

Note: This product cannot use reed switch type sensor switches.

- BCSA8
- BCSAR8 (corrosion resistant specification)

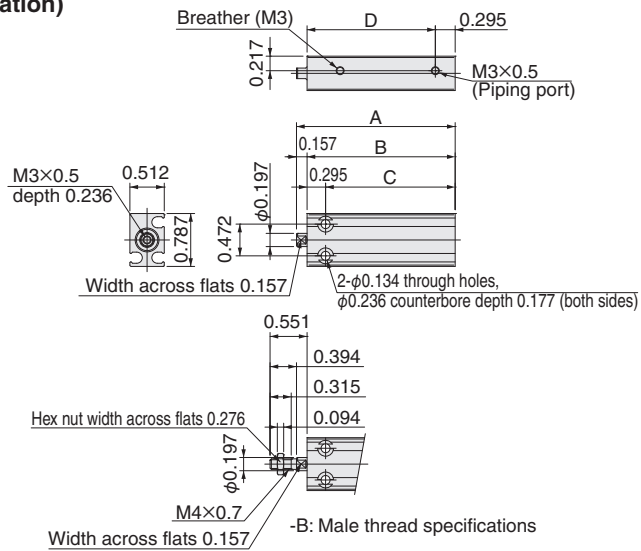

Stroke	A	B	C	D
5 mm [0.197]	1.969	1.811	1.516	1.516
10 mm [0.394]	2.165	2.008	1.713	1.713
15 mm [0.591]	2.362	2.205	1.909	1.909

Note: This product cannot use reed switch type sensor switches.

- BCSA10
- BCSAR10 (corrosion resistant specification)

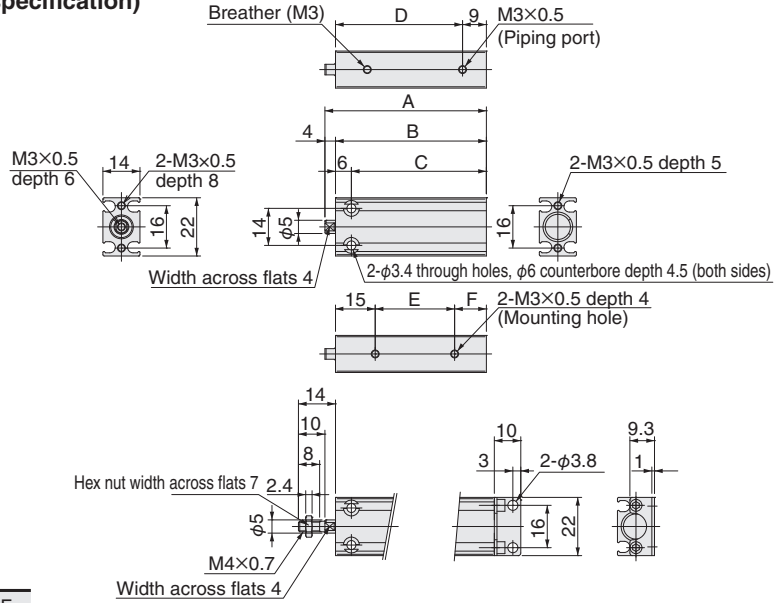

Stroke	A	B	C	D	E	F
5	51	47	41	38	20	12
10	56	52	46	43	20	17
15	61	57	51	48	30	12

-B: Male thread specifications -BK: With bracket (shipped attached)

Note: This product cannot use reed switch type sensor switches.

- BCSA12
- BCSAR12 (corrosion resistant specification)

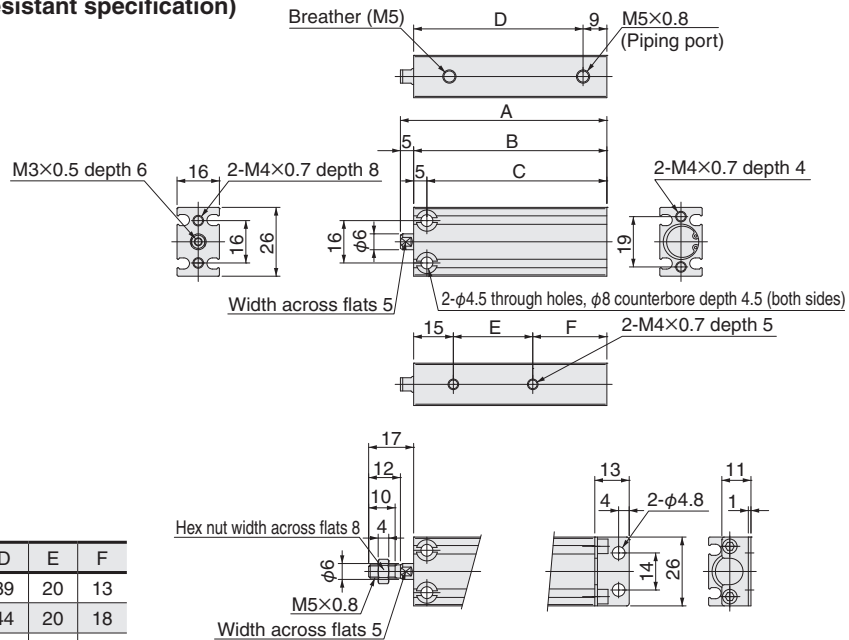

Stroke	A	B	C	D	E	F
5	53	48	43	39	20	13
10	58	53	48	44	20	18
15	63	58	53	49	30	13
20	68	63	58	54	30	18
25	73	68	63	59	40	13
30	78	73	68	64	40	18

-B: Male thread specifications -BK: With bracket (shipped attached)

Note: This product cannot use reed switch type sensor switches.

- BCSA10
- BCSAR10 (corrosion resistant specification)

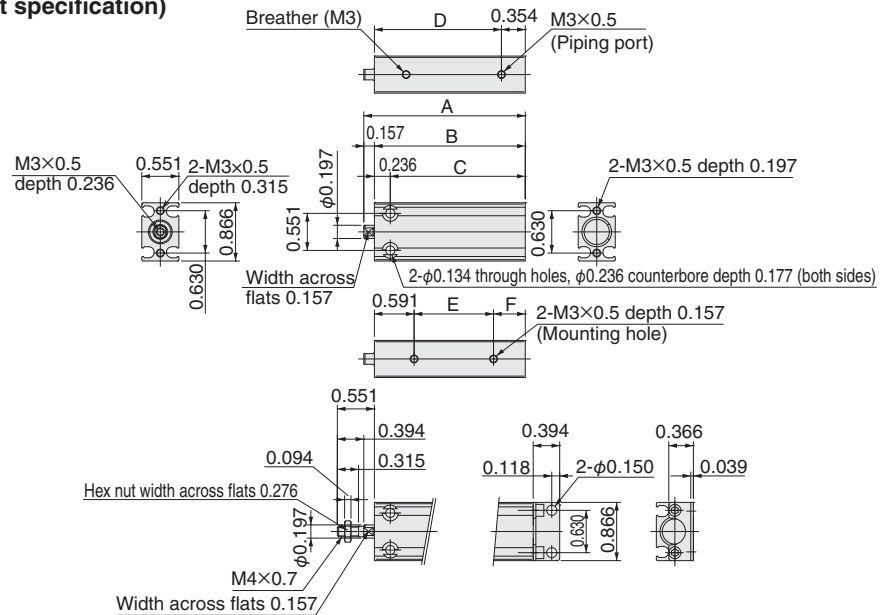

-B: Male thread specifications -BK: With bracket (shipped attached)

Stroke	A	B	C	D	E	F
5 mm [0.197]	2.008	1.850	1.614	1.496	0.787	0.472
10 mm [0.394]	2.205	2.047	1.811	1.693	0.787	0.669
15 mm [0.591]	2.402	2.244	2.008	1.890	1.181	0.472

Note: This product cannot use reed switch type sensor switches.

- BCSA12
- BCSAR12 (corrosion resistant specification)

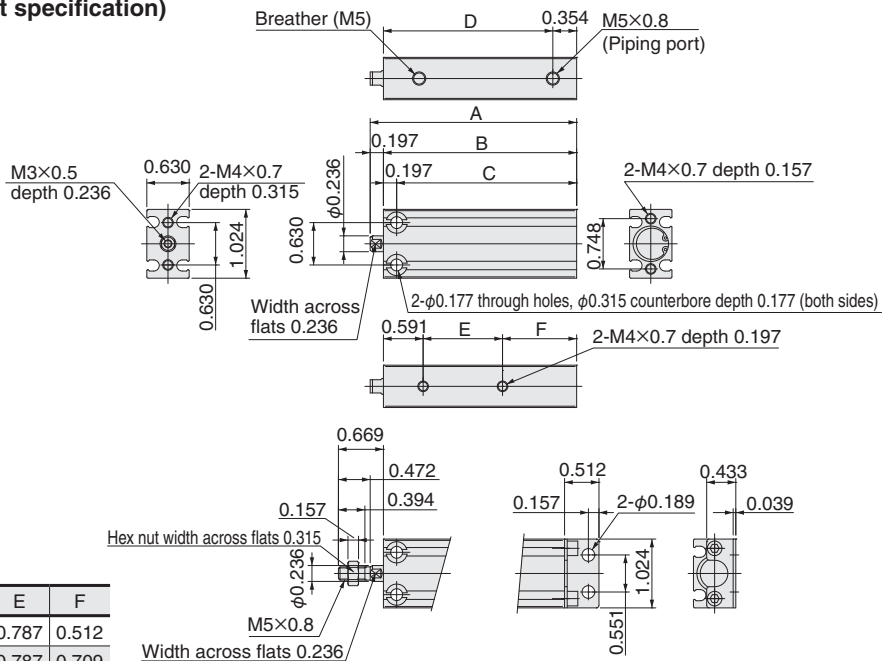

-B: Male thread specifications -BK: With bracket (shipped attached)

Stroke	A	B	C	D	E	F
5 mm [0.197]	2.087	1.890	1.693	1.535	0.787	0.512
10 mm [0.394]	2.283	2.087	1.890	1.732	0.787	0.709
15 mm [0.591]	2.480	2.283	2.087	1.929	1.181	0.512
20 mm [0.787]	2.677	2.480	2.283	2.126	1.181	0.709
25 mm [0.984]	2.874	2.677	2.480	2.323	1.575	0.512
30 mm [1.181]	3.071	2.874	2.677	2.520	1.575	0.709

Note: This product cannot use reed switch type sensor switches.

Single acting push type dimensions

unit: mm

- BCSA16
- BCSAR16 (corrosion resistant specification)

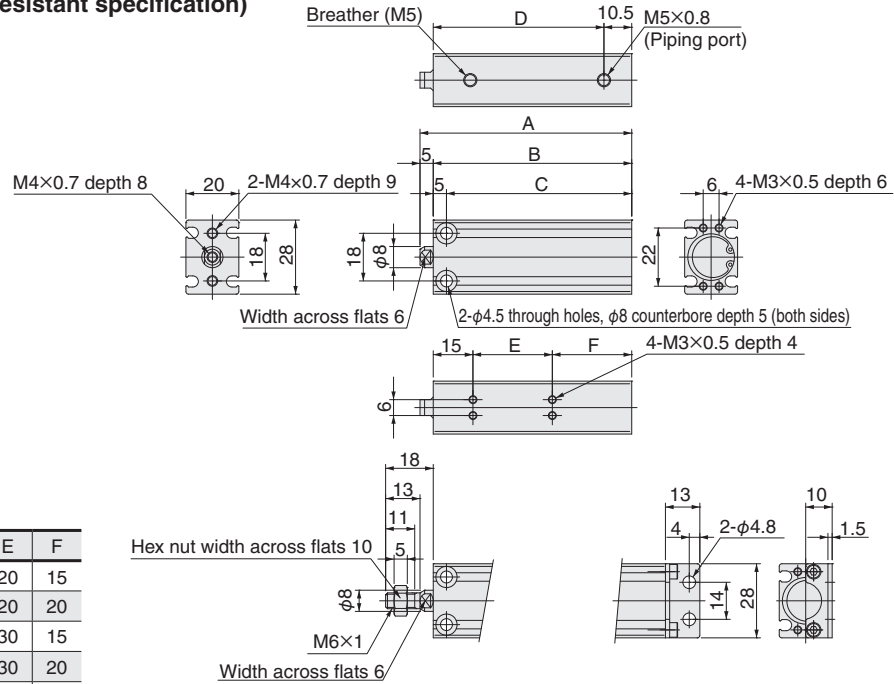

Stroke	A	B	C	D	E	F
5	55	50	45	39.5	20	15
10	60	55	50	44.5	20	20
15	65	60	55	49.5	30	15
20	70	65	60	54.5	30	20
25	75	70	65	59.5	40	15
30	80	75	70	64.5	40	20

-B: Male thread specifications

-BK: With bracket (shipped attached)

- BCSA20
- BCSAR20 (corrosion resistant specification)

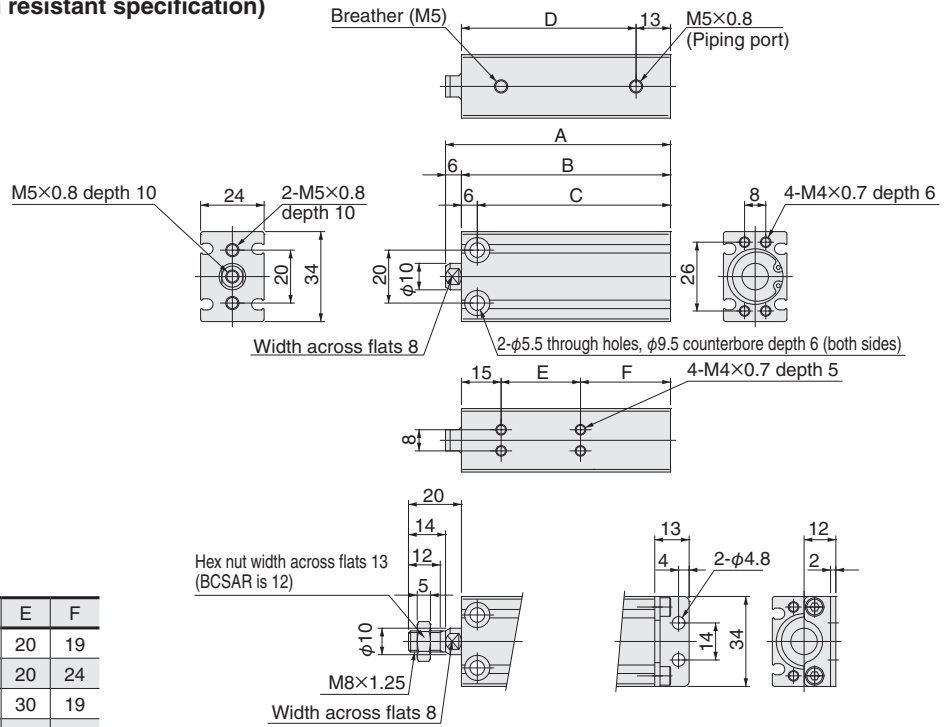

Stroke	A	B	C	D	E	F
5	60	54	48	41	20	19
10	65	59	53	46	20	24
15	70	64	58	51	30	19
20	75	69	63	56	30	24
25	80	74	68	61	40	19
30	85	79	73	66	40	24

-B: Male thread specifications

-BK: With bracket (shipped attached)

- BCSA16
- BCSAR16 (corrosion resistant specification)

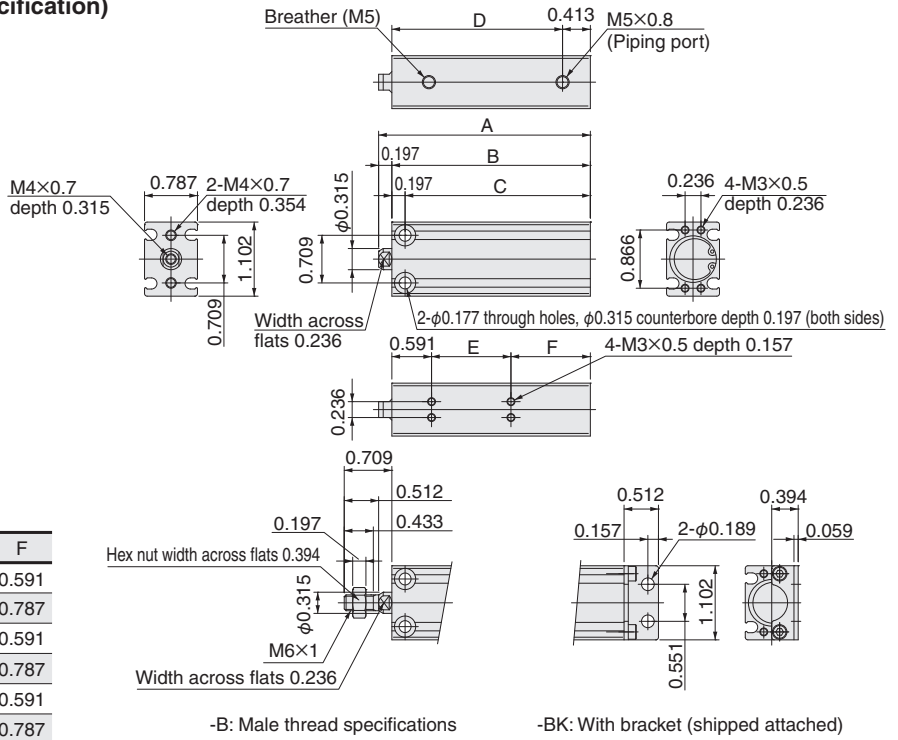

Stroke	A	B	C	D	E	F
5 mm [0.197]	2.165	1.969	1.772	1.555	0.787	0.591
10 mm [0.394]	2.362	2.165	1.969	1.752	0.787	0.787
15 mm [0.591]	2.559	2.362	2.165	1.949	1.181	0.591
20 mm [0.787]	2.756	2.559	2.362	2.146	1.181	0.787
25 mm [0.984]	2.953	2.756	2.559	2.343	1.575	0.591
30 mm [1.181]	3.150	2.953	2.756	2.539	1.575	0.787

- BCSA20
- BCSAR20 (corrosion resistant specification)

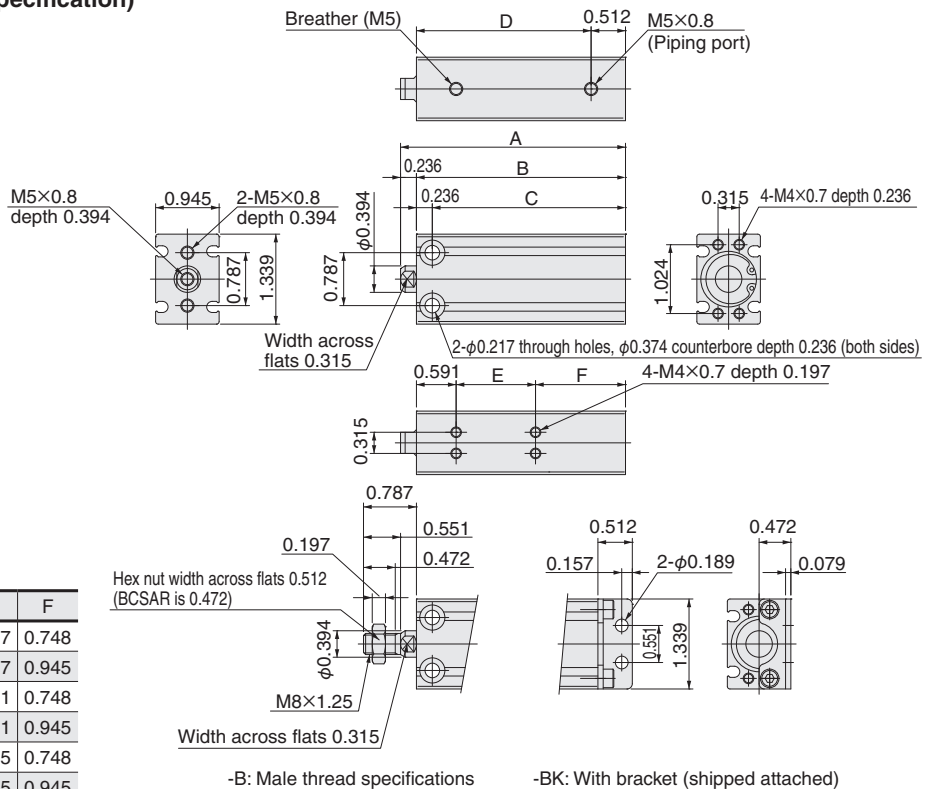

Stroke	A	B	C	D	E	F
5 mm [0.197]	2.362	2.126	1.890	1.614	0.787	0.748
10 mm [0.394]	2.559	2.323	2.087	1.811	0.787	0.945
15 mm [0.591]	2.756	2.520	2.283	2.008	1.181	0.748
20 mm [0.787]	2.953	2.717	2.480	2.205	1.181	0.945
25 mm [0.984]	3.150	2.913	2.677	2.402	1.575	0.748
30 mm [1.181]	3.346	3.110	2.874	2.598	1.575	0.945

- BCSA25
- BCSAR25 (corrosion resistant specification)

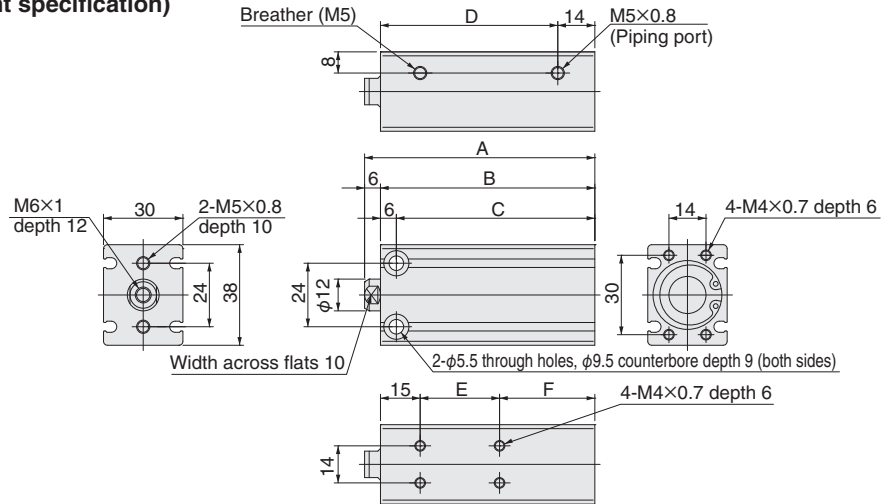

Stroke	A	B	C	D	E	F
5	62	56	50	42	20	21
10	67	61	55	47	20	26
15	72	66	60	52	30	21
20	77	71	65	57	30	26
25	82	76	70	62	40	21
30	87	81	75	67	40	26

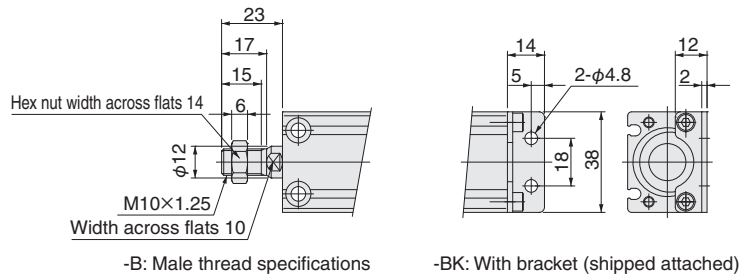

-B: Male thread specifications

-BK: With bracket (shipped attached)

- BCSA32
- BCSAR32 (corrosion resistant specification)

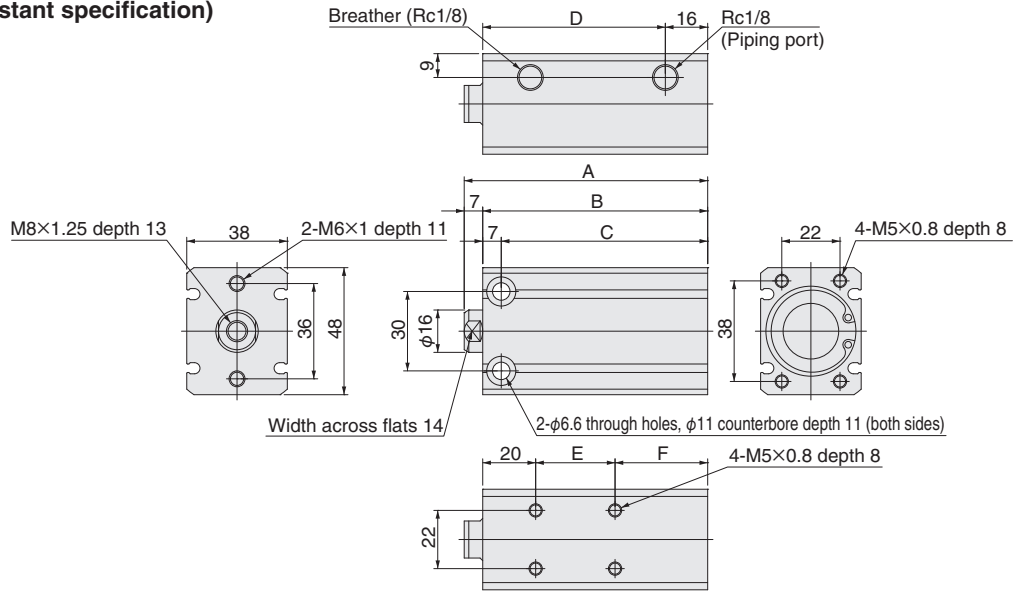

Stroke	A	B	C	D	E	F
10	72	65	58	49	20	25
15	77	70	63	54	30	20
20	82	75	68	59	30	25
25	87	80	73	64	40	20
30	92	85	78	69	40	25

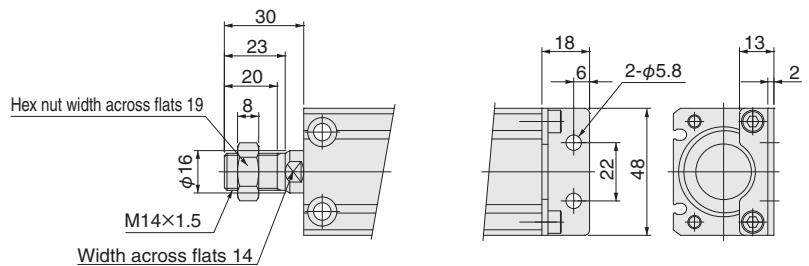

-B: Male thread specifications

-BK: With bracket (shipped attached)

- BCSA25
- BCSAR25 (corrosion resistant specification)

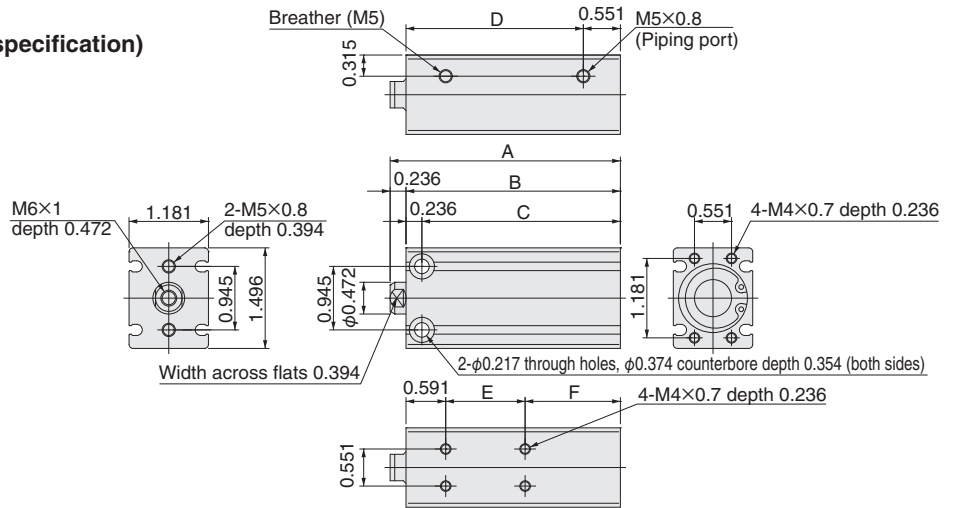

Stroke	A	B	C	D	E	F
5 mm [0.197]	2.441	2.205	1.969	1.654	0.787	0.827
10 mm [0.394]	2.638	2.402	2.165	1.850	0.787	1.024
15 mm [0.591]	2.835	2.598	2.362	2.047	1.181	0.827
20 mm [0.787]	3.031	2.795	2.559	2.244	1.181	1.024
25 mm [0.984]	3.228	2.992	2.756	2.441	1.575	0.827
30 mm [1.181]	3.425	3.189	2.953	2.638	1.575	1.024

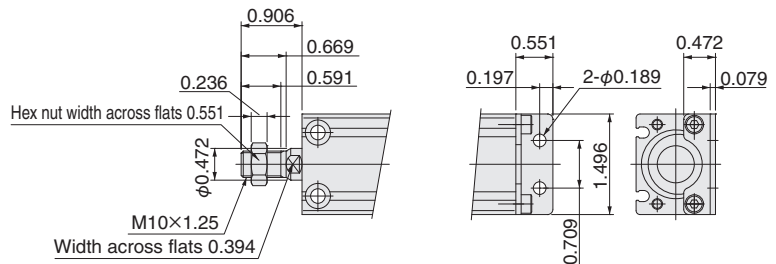

-B: Male thread specifications -BK: With bracket (shipped attached)

- BCSA32
- BCSAR32 (corrosion resistant specification)

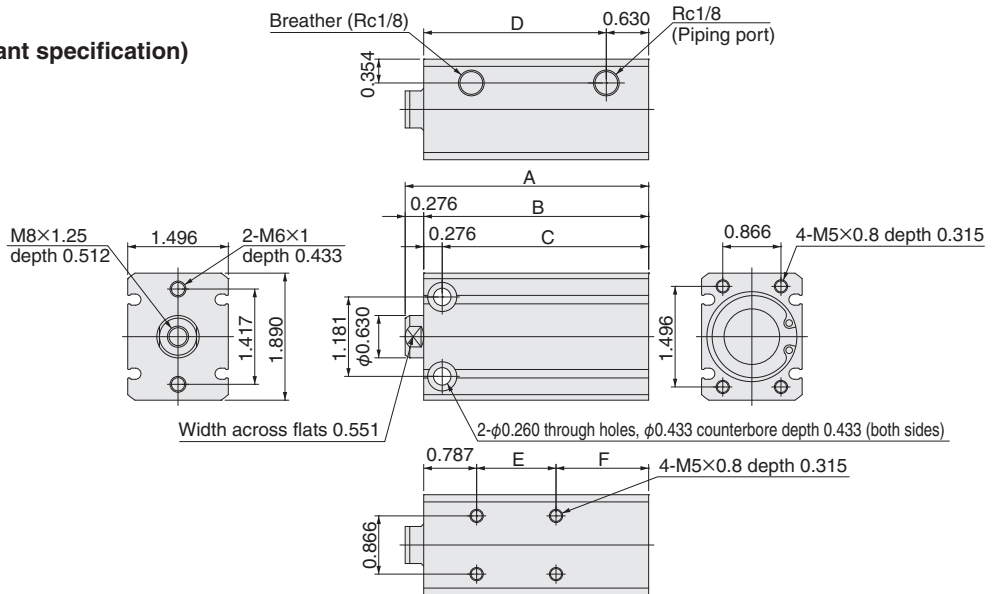

Stroke	A	B	C	D	E	F
10 mm [0.394]	2.835	2.559	2.283	1.929	0.787	0.984
15 mm [0.591]	3.031	2.756	2.480	2.126	1.181	0.787
20 mm [0.787]	3.228	2.953	2.677	2.323	1.181	0.984
25 mm [0.984]	3.425	3.150	2.874	2.520	1.575	0.787
30 mm [1.181]	3.622	3.346	3.071	2.717	1.575	0.984

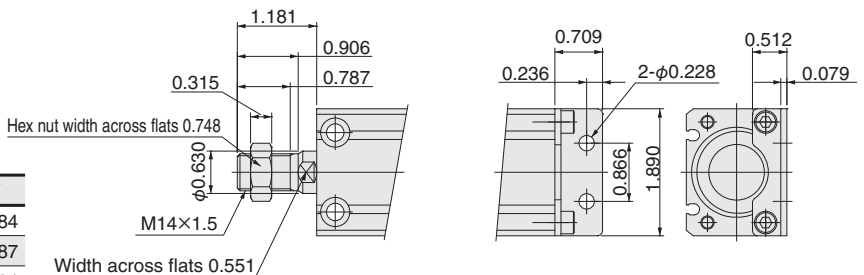

-B: Male thread specifications -BK: With bracket (shipped attached)

Single acting push type dimensions

unit: mm

- BCSA40
- BCSAR40 (corrosion resistant specification)

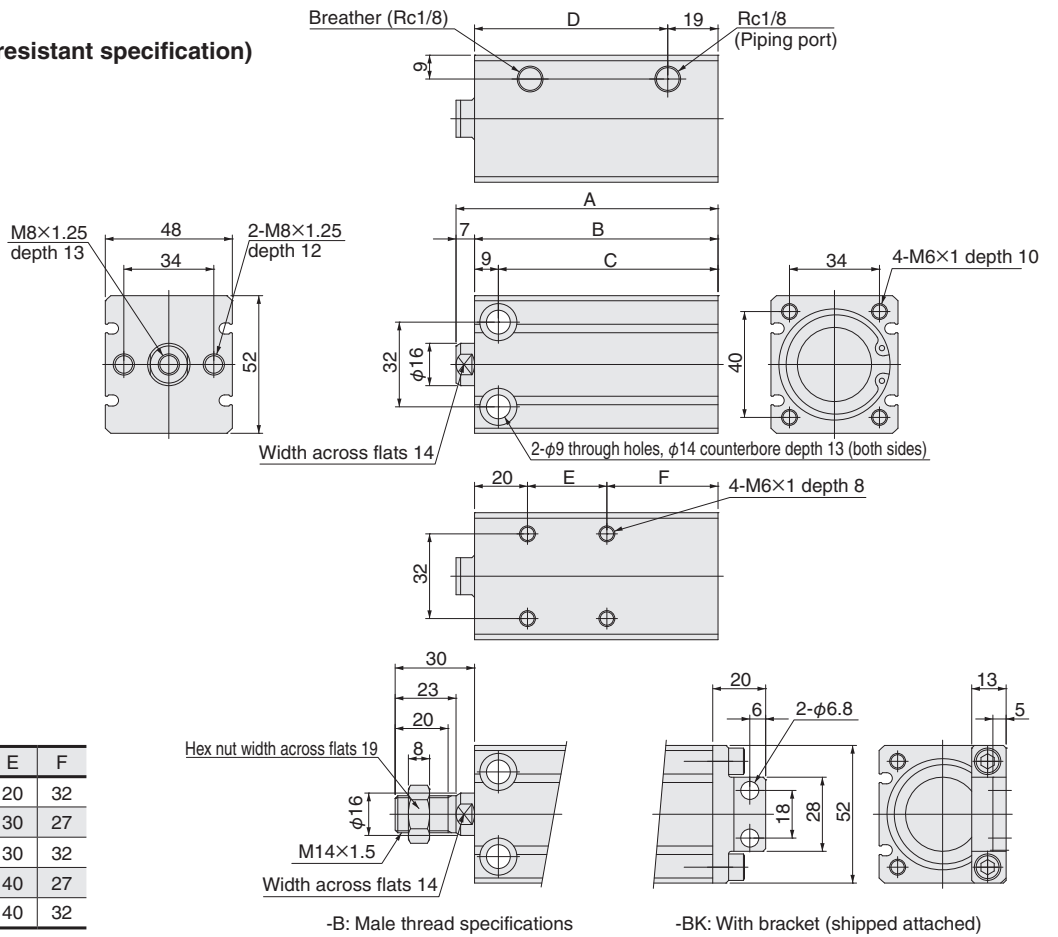

Stroke	A	B	C	D	E	F
10	79	72	63	53	20	32
15	84	77	68	58	30	27
20	89	82	73	63	30	32
25	94	87	78	68	40	27
30	99	92	83	73	40	32

- BCSA50
- BCSAR50 (corrosion resistant specification)

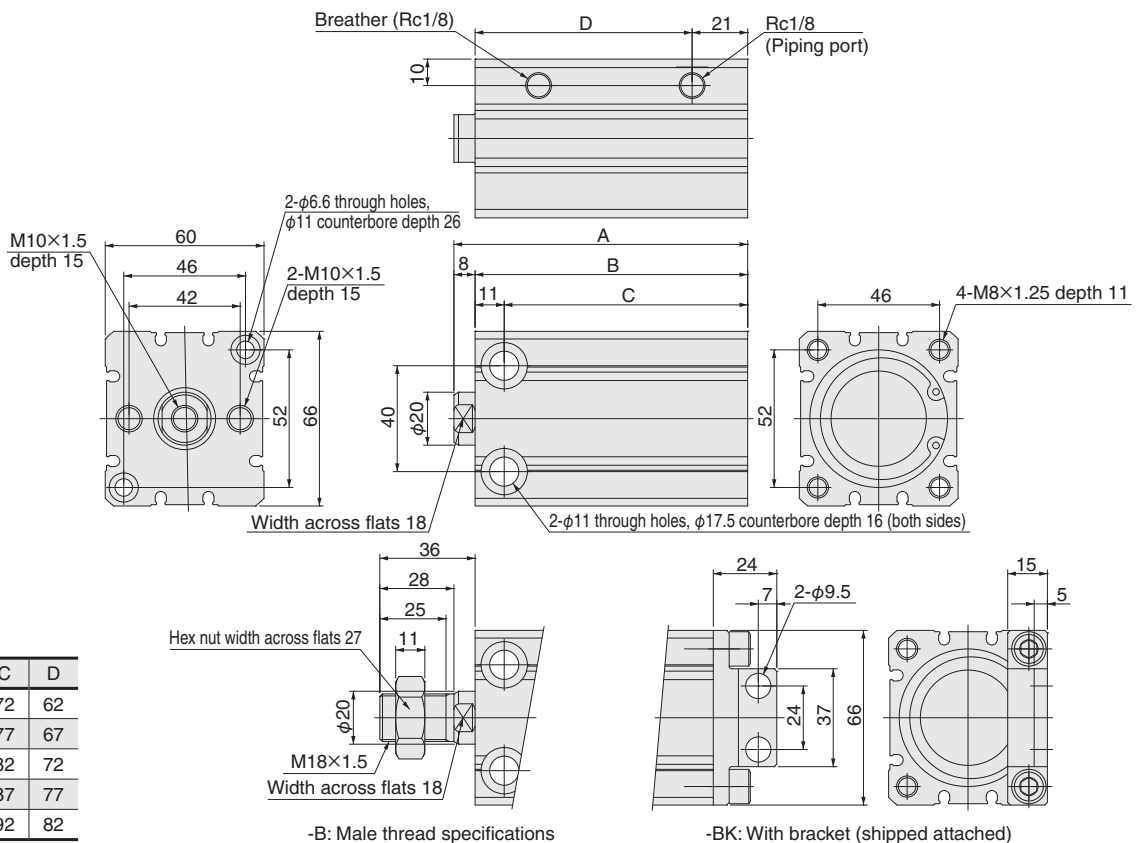

Stroke	A	B	C	D
10	91	83	72	62
15	96	88	77	67
20	101	93	82	72
25	106	98	87	77
30	111	103	92	82

Single acting push type dimensions

unit: in

- BCSA40
- BCSAR40 (corrosion resistant specification)

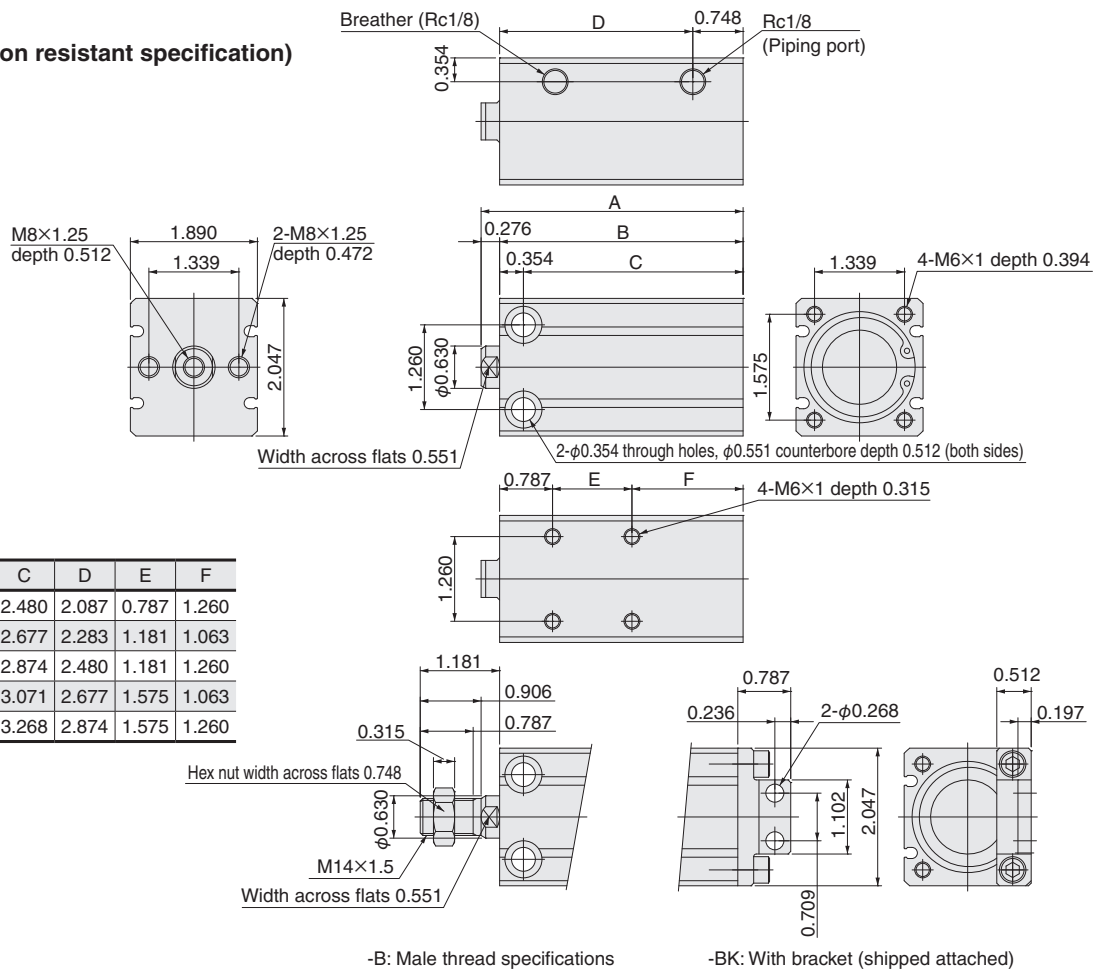

Stroke	A	B	C	D	E	F
10 mm [0.394]	3.110	2.835	2.480	2.087	0.787	1.260
15 mm [0.591]	3.307	3.031	2.677	2.283	1.181	1.063
20 mm [0.787]	3.504	3.228	2.874	2.480	1.181	1.260
25 mm [0.984]	3.701	3.425	3.071	2.677	1.575	1.063
30 mm [1.181]	3.898	3.622	3.268	2.874	1.575	1.260

- BCSA50
- BCSAR50 (corrosion resistant specification)

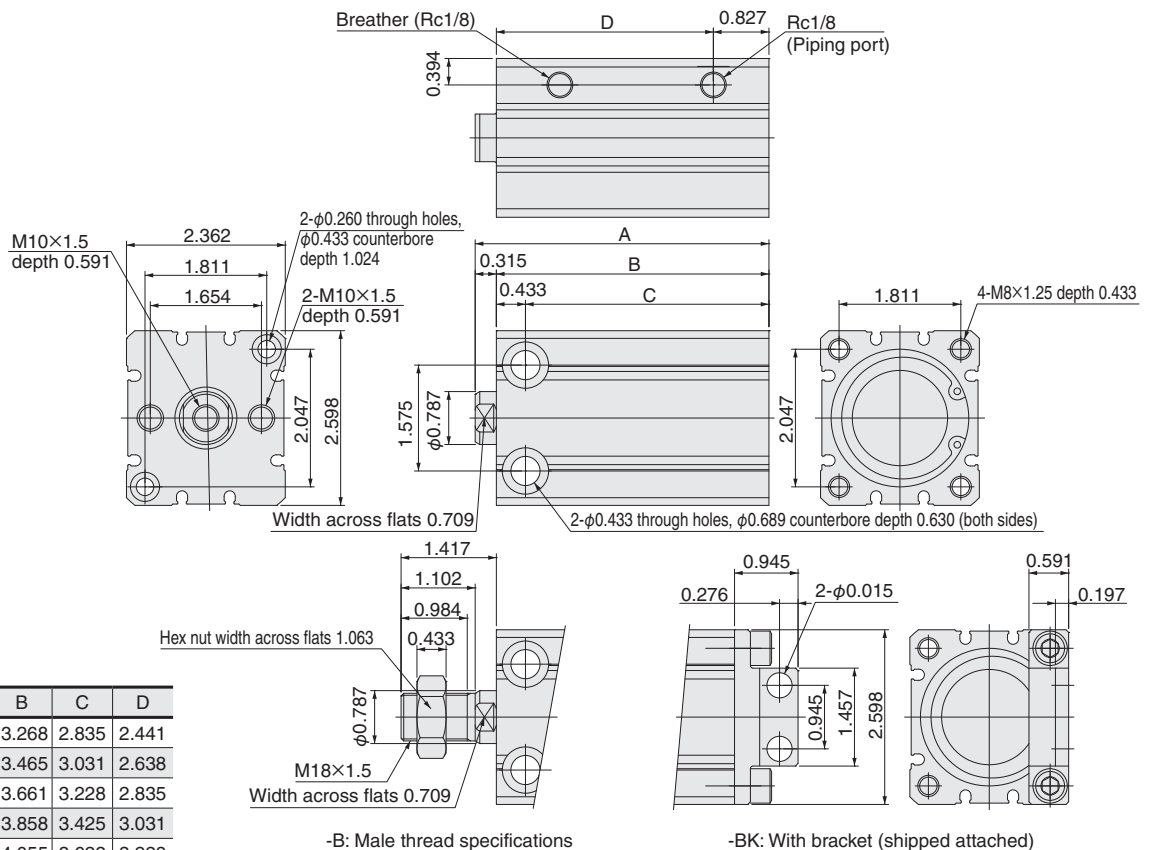

Stroke	A	B	C	D
10 mm [0.394]	3.583	3.268	2.835	2.441
15 mm [0.591]	3.780	3.465	3.031	2.638
20 mm [0.787]	3.976	3.661	3.228	2.835
25 mm [0.984]	4.173	3.858	3.425	3.031
30 mm [1.181]	4.370	4.055	3.622	3.228

- BCTA6
- BCTAR6 (corrosion resistant specification)

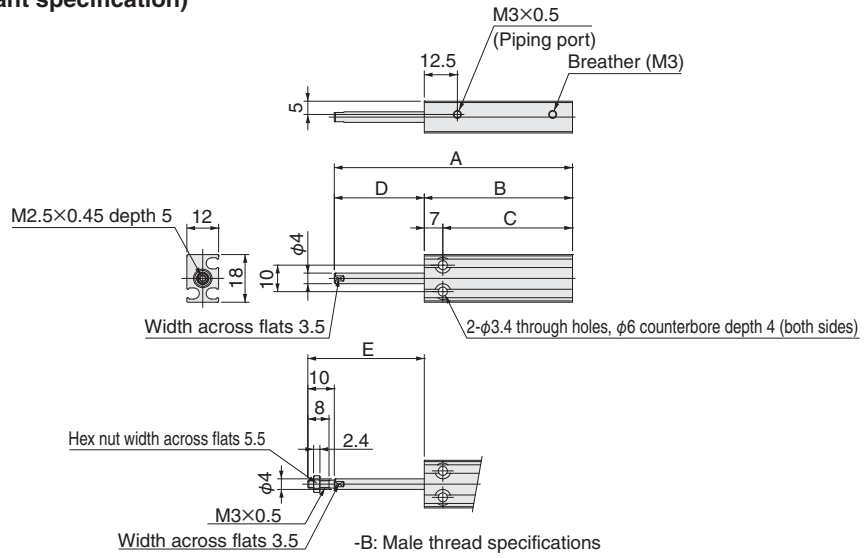

Stroke	A	B	C	D	E
5	55	46	39	9	19
10	65	51	44	14	24
15	75	56	49	19	29

Note: This product cannot use reed switch type sensor switches.

- BCTA8
- BCTAR8 (corrosion resistant specification)

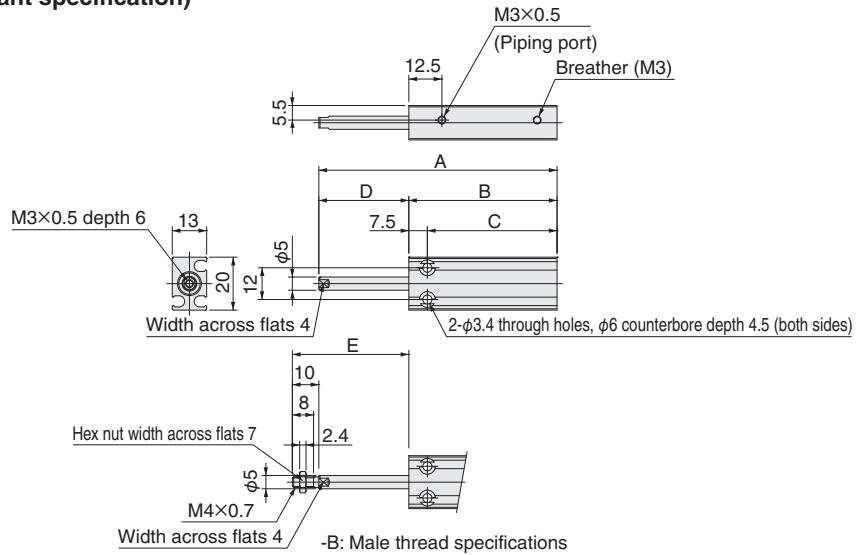

Stroke	A	B	C	D	E
5	55	46	38.5	9	19
10	65	51	43.5	14	24
15	75	56	48.5	19	29

Note: This product cannot use reed switch type sensor switches.

- BCTA6
- BCTAR6 (corrosion resistant specification)

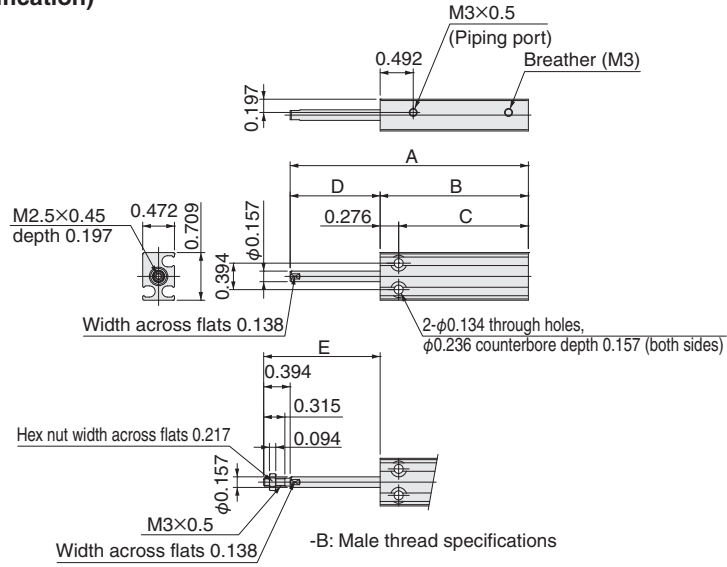

Stroke	A	B	C	D	E
5 mm [0.197]	2.165	1.811	1.535	0.354	0.748
10 mm [0.394]	2.559	2.008	1.732	0.551	0.945
15 mm [0.591]	2.953	2.205	1.929	0.748	1.142

Note: This product cannot use reed switch type sensor switches.

- BCTA8
- BCTAR8 (corrosion resistant specification)

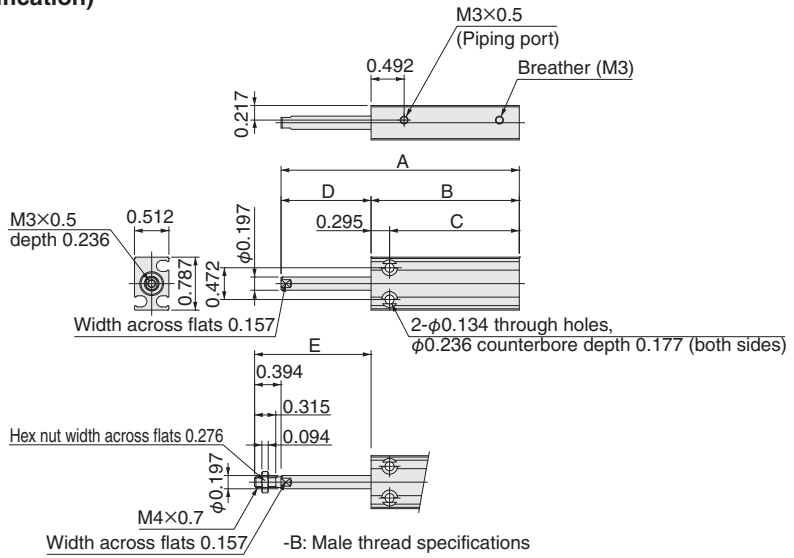

Stroke	A	B	C	D	E
5 mm [0.197]	2.165	1.811	1.516	0.354	0.748
10 mm [0.394]	2.559	2.008	1.713	0.551	0.945
15 mm [0.591]	2.953	2.205	1.909	0.748	1.142

Note: This product cannot use reed switch type sensor switches.

- BCTA10
- BCTAR10 (corrosion resistant specification)

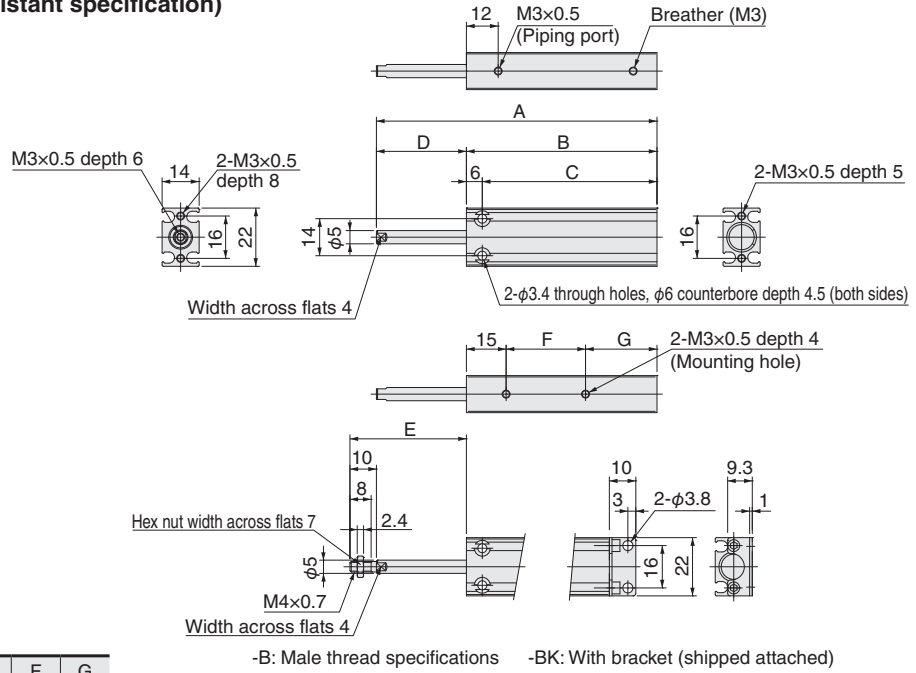

Stroke	A	B	C	D	E	F	G
5	56	47	41	9	19	20	12
10	66	52	46	14	24	20	17
15	76	57	51	19	29	30	12

-B: Male thread specifications -BK: With bracket (shipped attached)

Note: This product cannot use reed switch type sensor switches.

- BCTA12
- BCTAR12 (corrosion resistant specification)

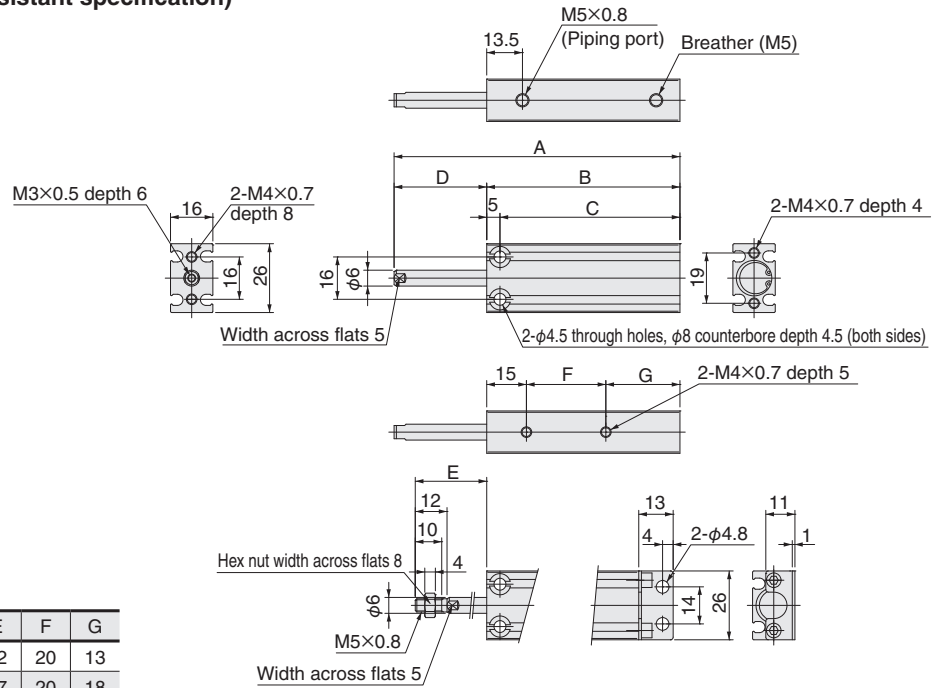

Stroke	A	B	C	D	E	F	G
5	58	48	43	10	22	20	13
10	68	53	48	15	27	20	18
15	78	58	53	20	32	30	13
20	88	63	58	25	37	30	18
25	98	68	63	30	42	40	13
30	108	73	68	35	47	40	18

-B: Male thread specifications -BK: With bracket (shipped attached)

Note: This product cannot use reed switch type sensor switches.

- BCTA10
- BCTAR10 (corrosion resistant specification)

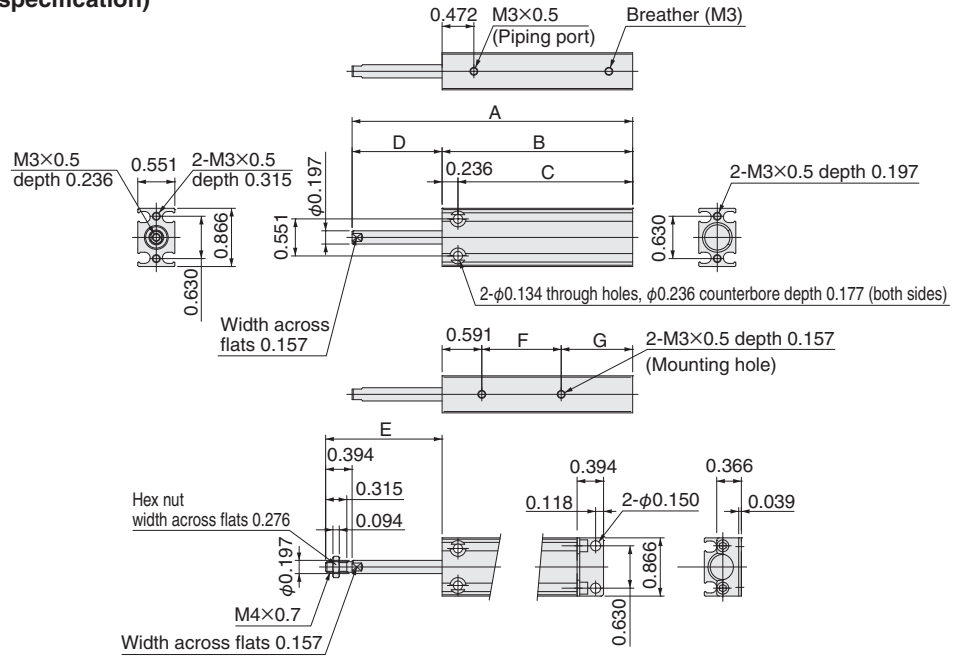

Stroke	A	B	C	D	E	F	G
5 mm [0.197]	2.205	1.850	1.614	0.354	0.748	0.787	0.472
10 mm [0.394]	2.598	2.047	1.811	0.551	0.945	0.787	0.669
15 mm [0.591]	2.992	2.244	2.008	0.748	1.142	1.181	0.472

-B: Male thread specifications -BK: With bracket (shipped attached)

Note: This product cannot use reed switch type sensor switches.

- BCTA12
- BCTAR12 (corrosion resistant specification)

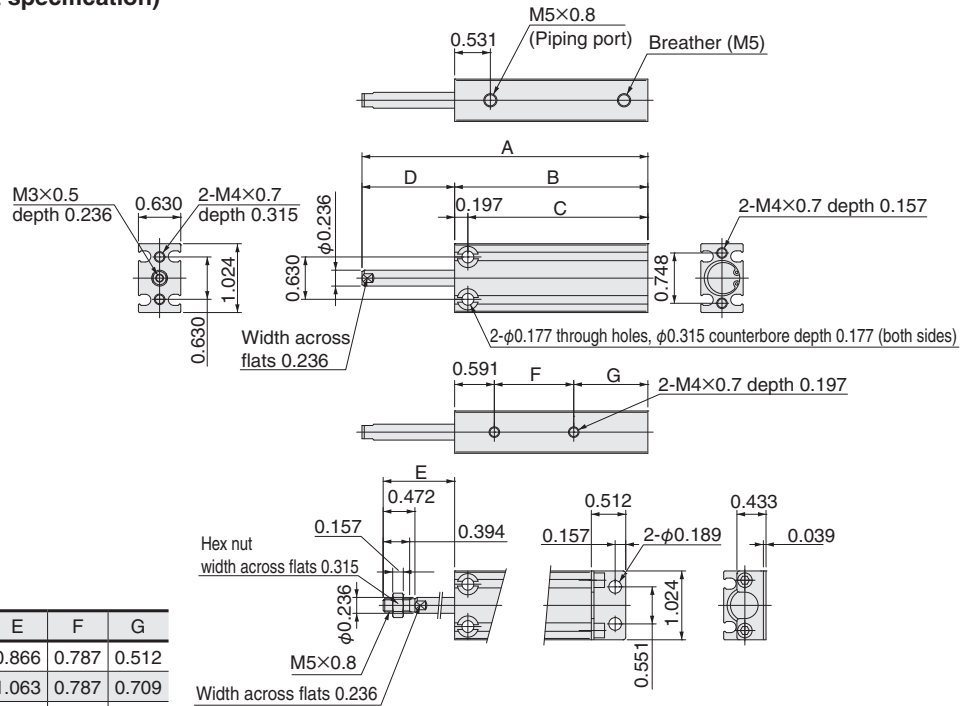

Stroke	A	B	C	D	E	F	G
5 mm [0.197]	2.283	1.890	1.693	0.394	0.866	0.787	0.512
10 mm [0.394]	2.677	2.087	1.890	0.591	1.063	0.787	0.709
15 mm [0.591]	3.071	2.283	2.087	0.787	1.260	1.181	0.512
20 mm [0.787]	3.465	2.480	2.283	0.984	1.457	1.181	0.709
25 mm [0.984]	3.858	2.677	2.480	1.181	1.654	1.575	0.512
30 mm [1.181]	4.252	2.874	2.677	1.378	1.850	1.575	0.709

-B: Male thread specifications -BK: With bracket (shipped attached)

Note: This product cannot use reed switch type sensor switches.

- BCTA16
- BCTAR16 (corrosion resistant specification)

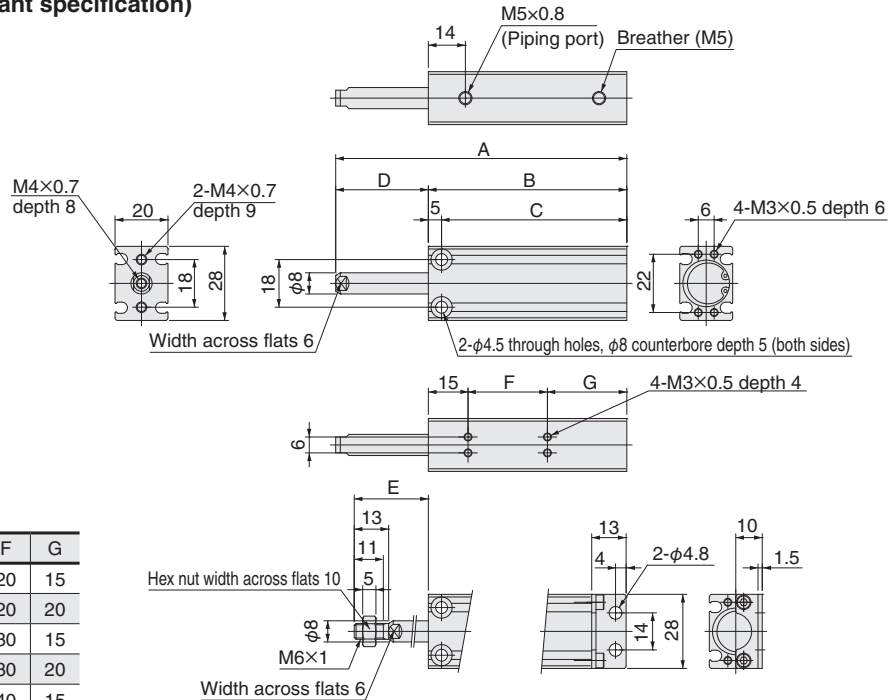

Stroke	A	B	C	D	E	F	G
5	60	50	45	10	23	20	15
10	70	55	50	15	28	20	20
15	80	60	55	20	33	30	15
20	90	65	60	25	38	30	20
25	100	70	65	30	43	40	15
30	110	75	70	35	48	40	20

-B: Male thread specifications -BK: With bracket (shipped attached)

- BCTA20
- BCTAR20 (corrosion resistant specification)

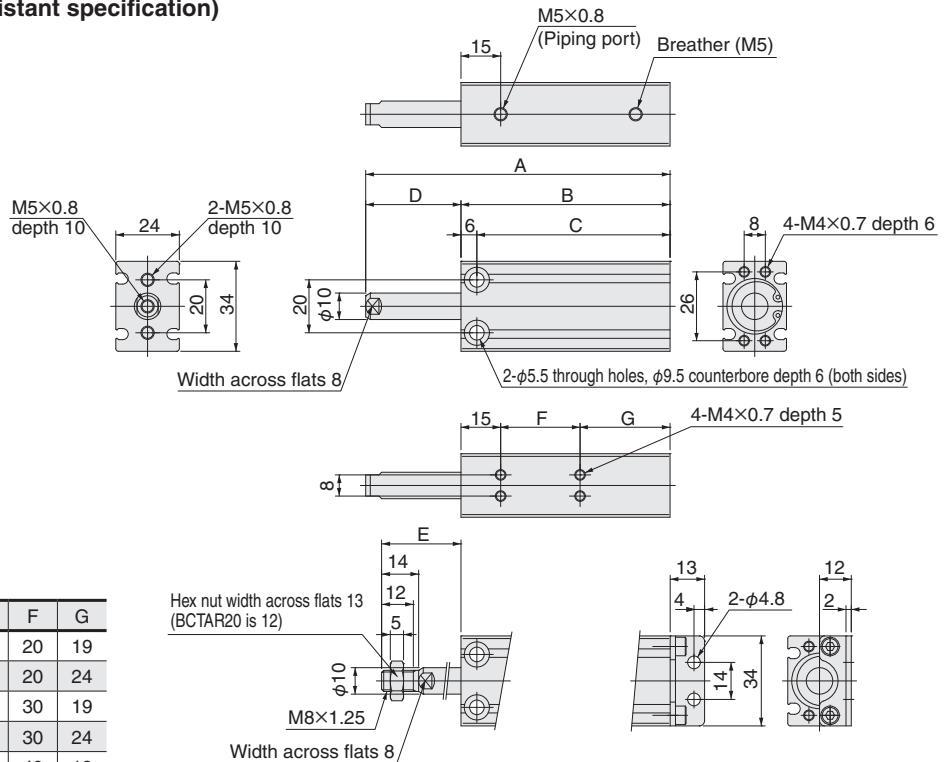

Stroke	A	B	C	D	E	F	G
5	65	54	48	11	25	20	19
10	75	59	53	16	30	20	24
15	85	64	58	21	35	30	19
20	95	69	63	26	40	30	24
25	105	74	68	31	45	40	19
30	115	79	73	36	50	40	24

-B: Male thread specifications -BK: With bracket (shipped attached)

- BCTA16
- BCTAR16 (corrosion resistant specification)

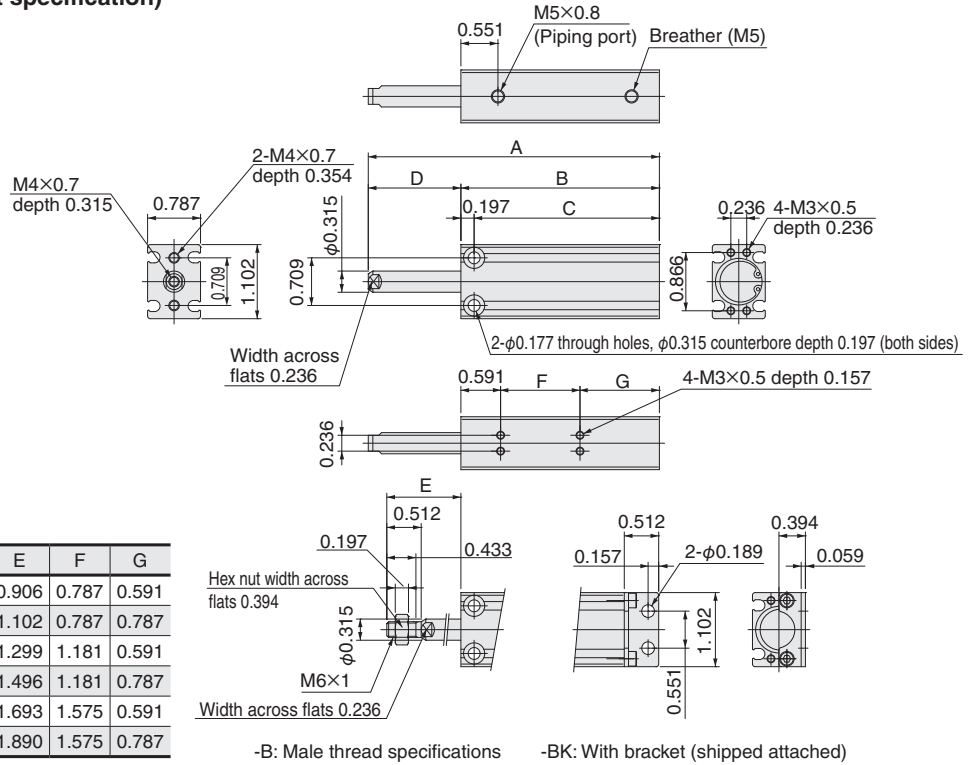

Stroke	A	B	C	D	E	F	G
5 mm [0.197]	2.362	1.969	1.772	0.394	0.906	0.787	0.591
10 mm [0.394]	2.756	2.165	1.969	0.591	1.102	0.787	0.787
15 mm [0.591]	3.150	2.362	2.165	0.787	1.299	1.181	0.591
20 mm [0.787]	3.543	2.559	2.362	0.984	1.496	1.181	0.787
25 mm [0.984]	3.937	2.756	2.559	1.181	1.693	1.575	0.591
30 mm [1.181]	4.331	2.953	2.756	1.378	1.890	1.575	0.787

- BCTA20
- BCTAR20 (corrosion resistant specification)

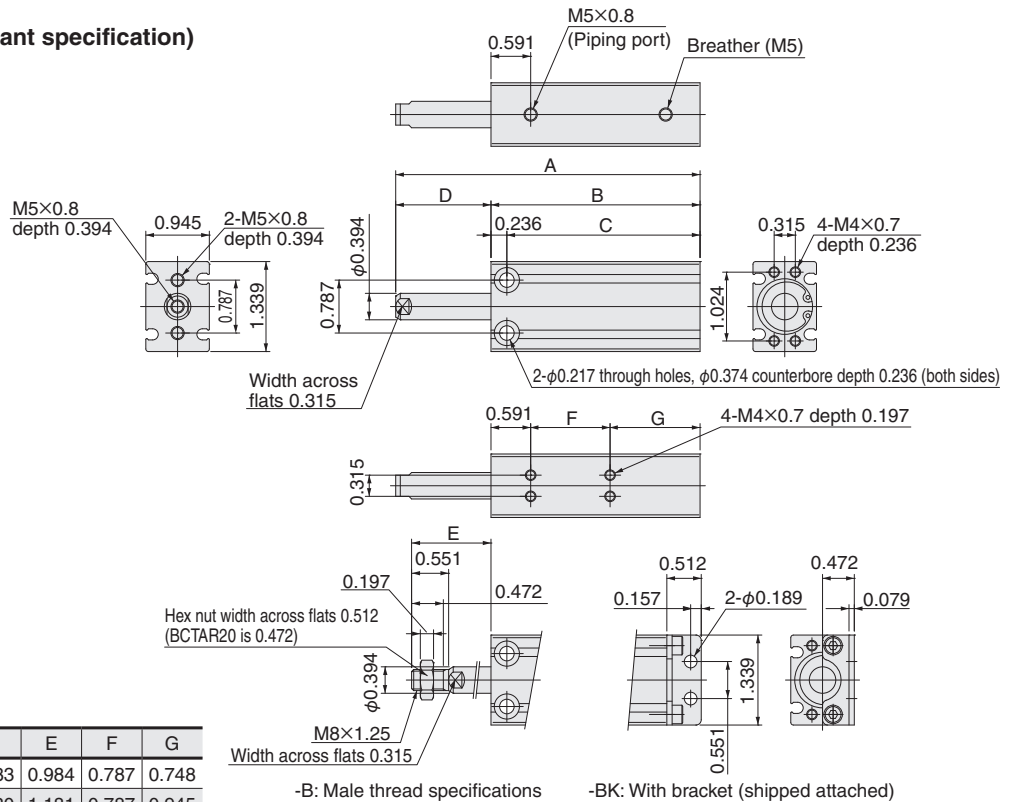

Stroke	A	B	C	D	E	F	G
5 mm [0.197]	2.559	2.126	1.890	0.433	0.984	0.787	0.748
10 mm [0.394]	2.953	2.323	2.087	0.630	1.181	0.787	0.945
15 mm [0.591]	3.346	2.520	2.283	0.827	1.378	1.181	0.748
20 mm [0.787]	3.740	2.717	2.480	1.024	1.575	1.181	0.945
25 mm [0.984]	4.134	2.913	2.677	1.220	1.772	1.575	0.748
30 mm [1.181]	4.528	3.110	2.874	1.417	1.969	1.575	0.945

Single acting pull type dimensions

unit: mm

- BCTA25
- BCTAR25 (corrosion resistant specification)

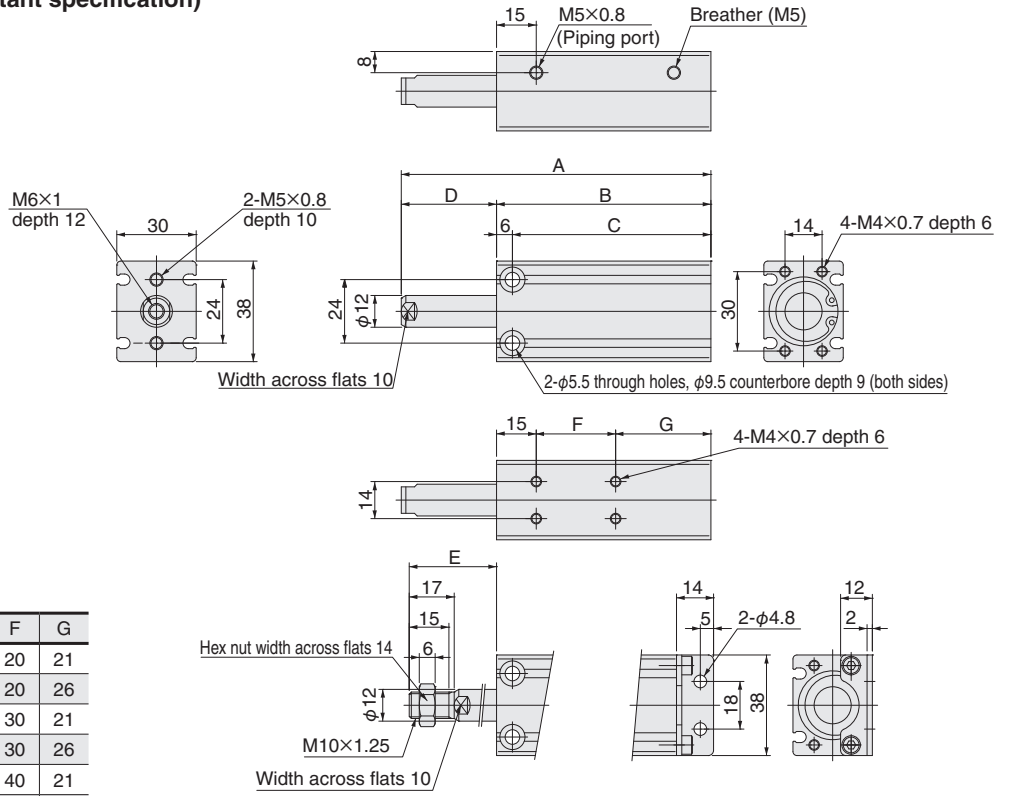

Stroke	A	B	C	D	E	F	G
5	67	56	50	11	28	20	21
10	77	61	55	16	33	20	26
15	87	66	60	21	38	30	21
20	97	71	65	26	43	30	26
25	107	76	70	31	48	40	21
30	117	81	75	36	53	40	26

-B: Male thread specifications -BK: With bracket (shipped attached)

- BCTA32
- BCTAR32 (corrosion resistant specification)

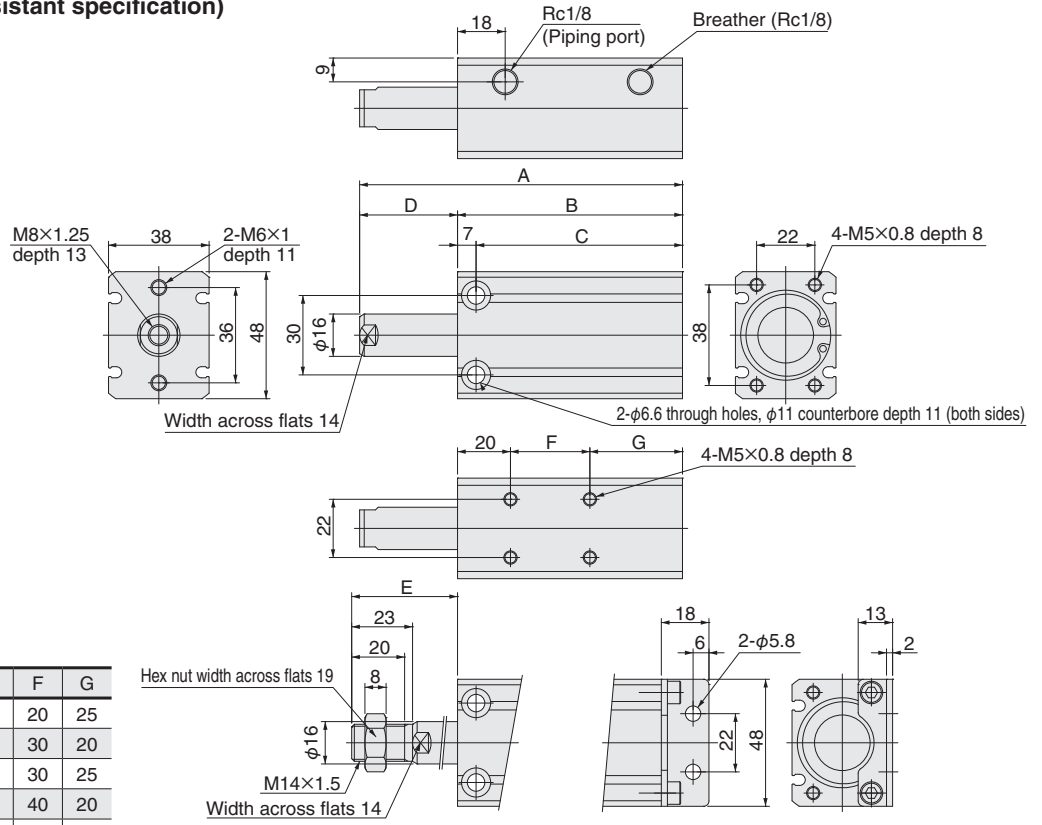

Stroke	A	B	C	D	E	F	G
10	82	65	58	17	40	20	25
15	92	70	63	22	45	30	20
20	102	75	68	27	50	30	25
25	112	80	73	32	55	40	20
30	122	85	78	37	60	40	25

-B: Male thread specifications -BK: With bracket (shipped attached)

- BCTA25
- BCTAR25 (corrosion resistant specification)

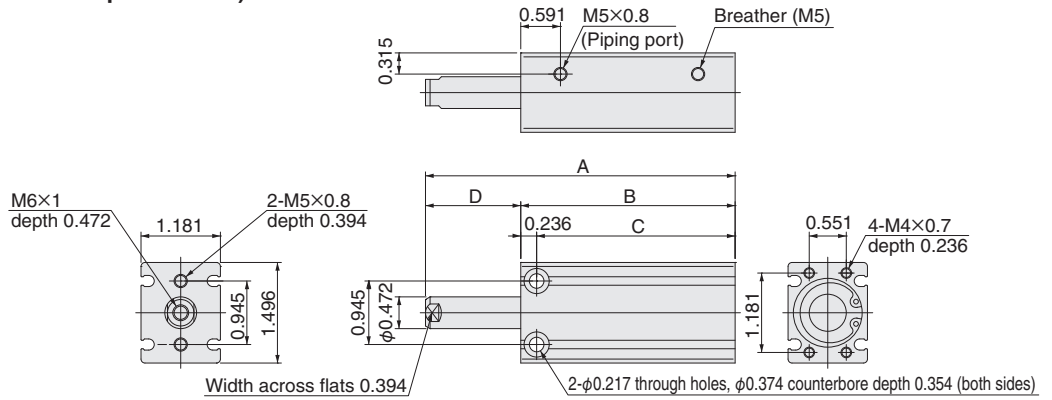

Stroke	A	B	C	D	E	F	G
5 mm [0.197]	2.638	2.205	1.969	0.433	1.102	0.787	0.827
10 mm [0.394]	3.031	2.402	2.165	0.630	1.299	0.787	1.024
15 mm [0.591]	3.425	2.598	2.362	0.827	1.496	1.181	0.827
20 mm [0.787]	3.819	2.795	2.559	1.024	1.693	1.181	1.024
25 mm [0.984]	4.213	2.992	2.756	1.220	1.890	1.575	0.827
30 mm [1.181]	4.606	3.189	2.953	1.417	2.087	1.575	1.024

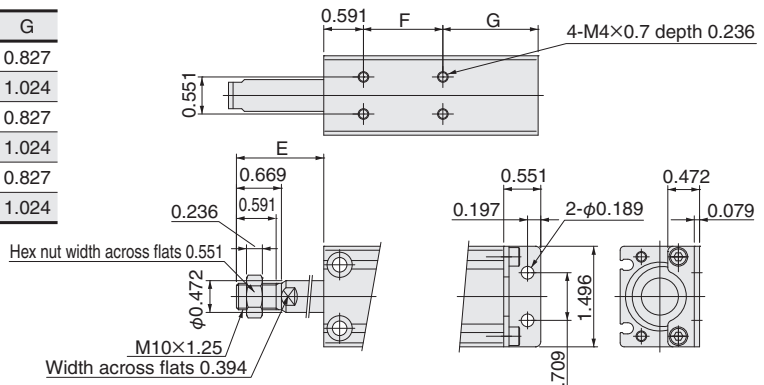

-B: Male thread specifications

-BK: With bracket (shipped attached)

- BCTA32
- BCTAR32 (corrosion resistant specification)

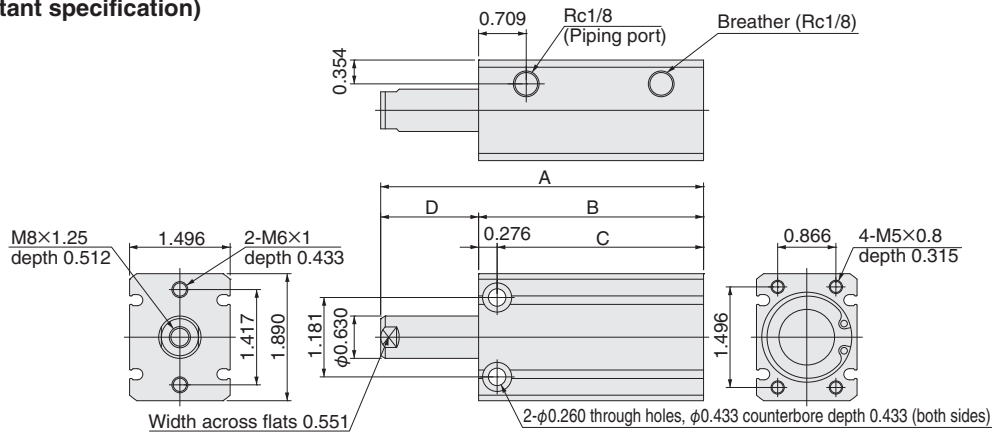

Stroke	A	B	C	D	E	F	G
10 mm [0.394]	3.228	2.559	2.283	0.669	1.575	0.787	0.984
15 mm [0.591]	3.622	2.756	2.480	0.866	1.772	1.181	0.787
20 mm [0.787]	4.016	2.953	2.677	1.063	1.969	1.181	0.984
25 mm [0.984]	4.409	3.150	2.874	1.260	2.165	1.575	0.787
30 mm [1.181]	4.803	3.346	3.071	1.457	2.362	1.575	0.984

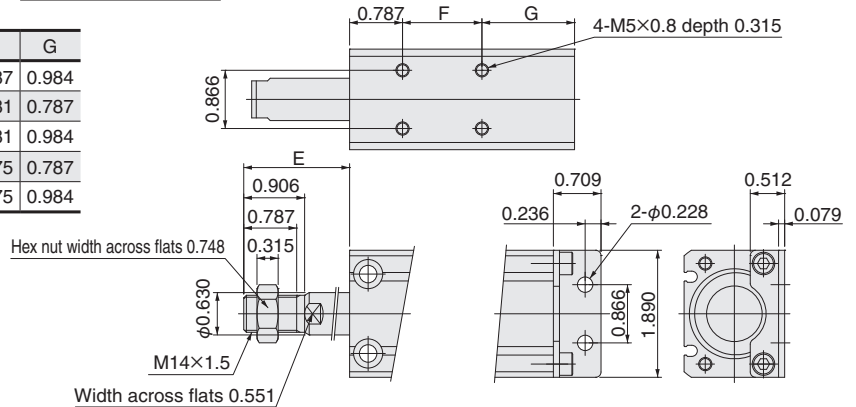

-B: Male thread specifications

-BK: With bracket (shipped attached)

Single acting pull type dimensions

unit: mm

- BCTA40
- BCTAR40 (corrosion resistant specification)

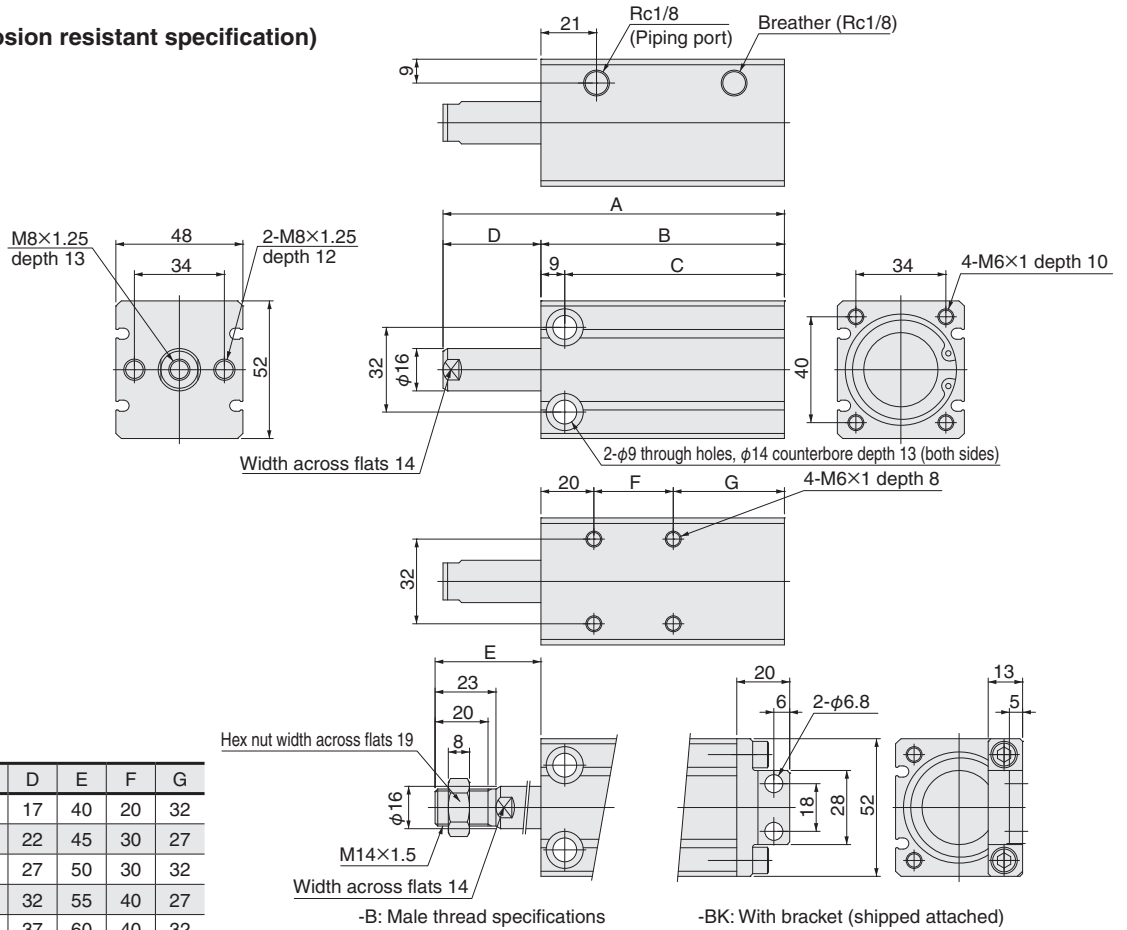

Stroke	A	B	C	D	E	F	G
10	89	72	63	17	40	20	32
15	99	77	68	22	45	30	27
20	109	82	73	27	50	30	32
25	119	87	78	32	55	40	27
30	129	92	83	37	60	40	32

- BCTA50
- BCTAR50 (corrosion resistant specification)

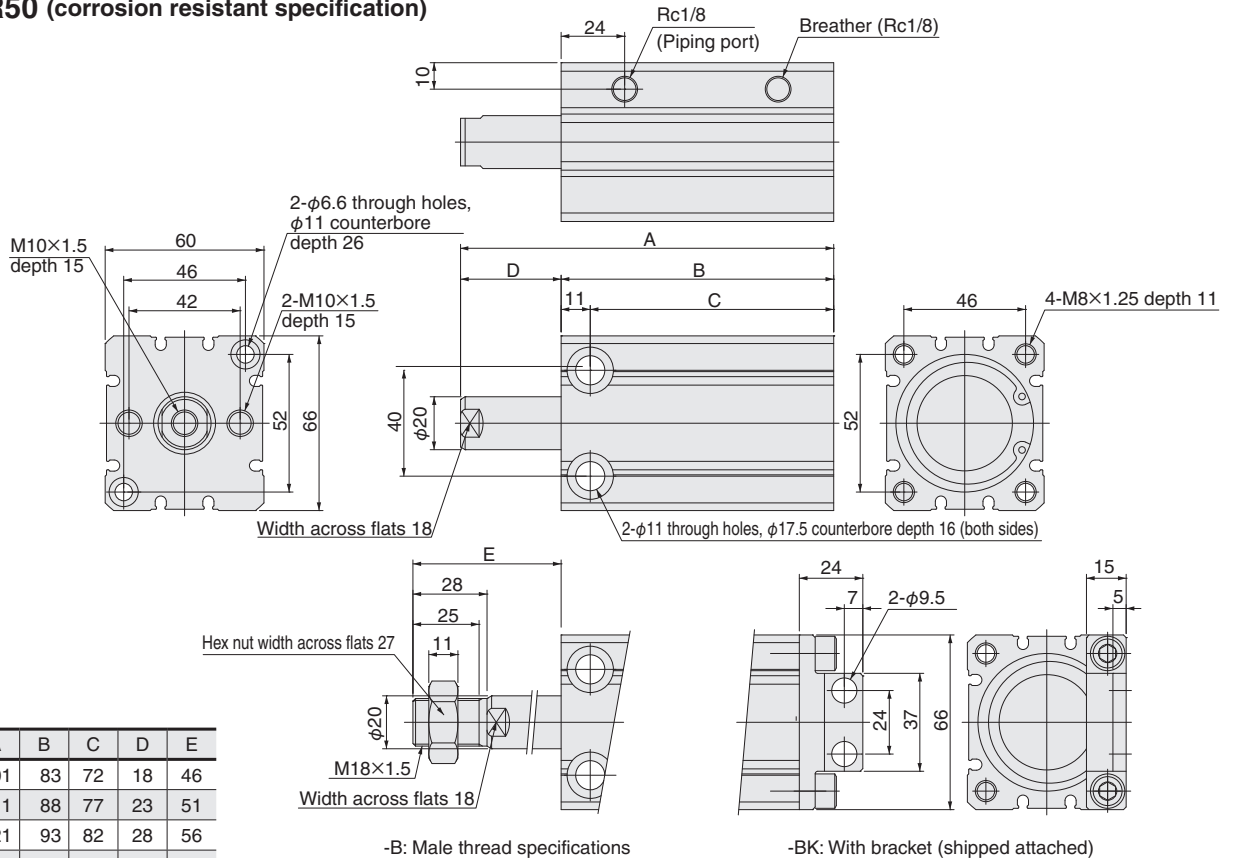

Stroke	A	B	C	D	E
10	101	83	72	18	46
15	111	88	77	23	51
20	121	93	82	28	56
25	131	98	87	33	61
30	141	103	92	38	66

- BCTA40
- BCTAR40 (corrosion resistant specification)

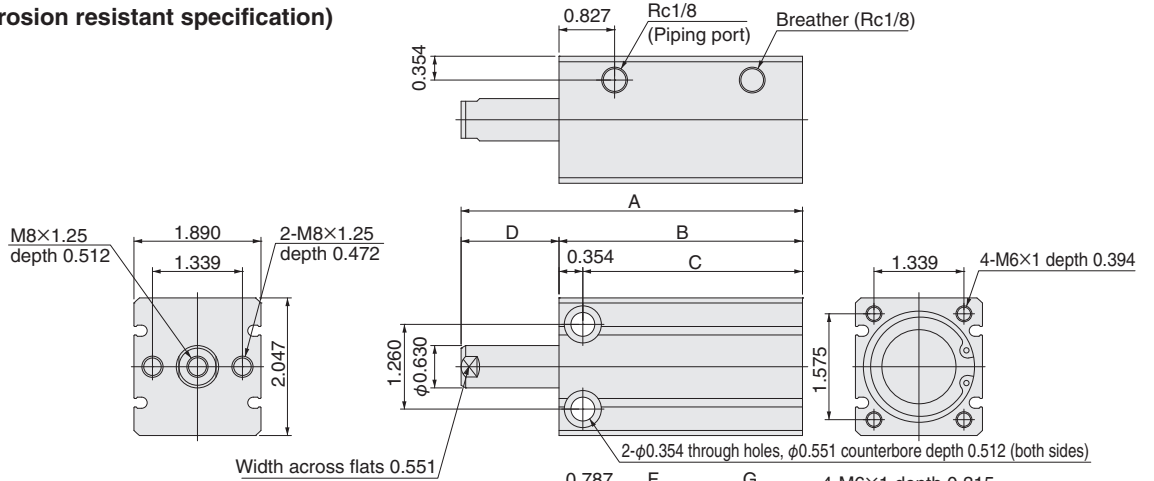

Stroke	A	B	C	D	E	F	G
10 mm [0.394]	3.504	2.835	2.480	0.669	1.575	0.787	1.260
15 mm [0.591]	3.898	3.031	2.677	0.866	1.772	1.181	1.063
20 mm [0.787]	4.291	3.228	2.874	1.063	1.969	1.181	1.260
25 mm [0.984]	4.685	3.425	3.071	1.260	2.165	1.575	1.063
30 mm [1.181]	5.079	3.622	3.268	1.457	2.362	1.575	1.260

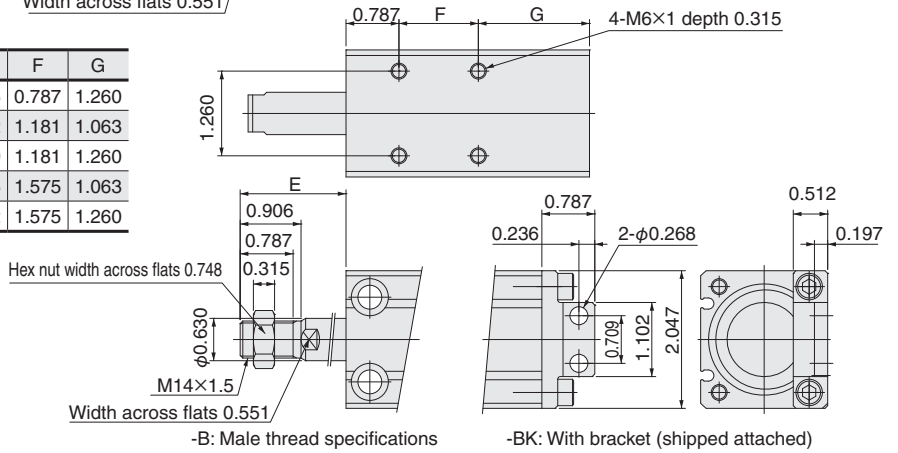

-B: Male thread specifications

-BK: With bracket (shipped attached)

- BCTA50
- BCTAR50 (corrosion resistant specification)

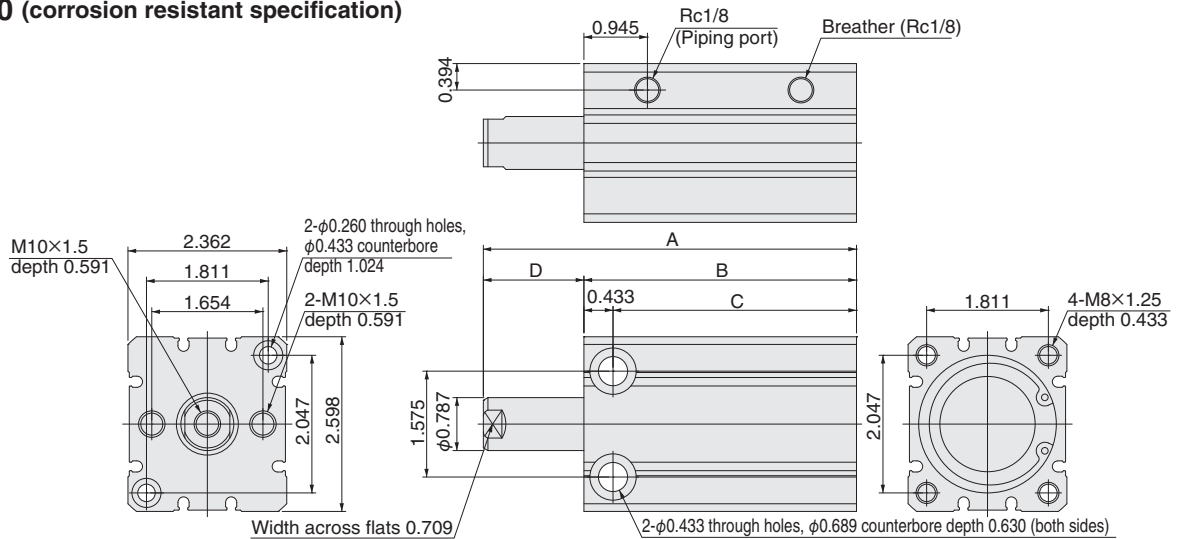

Stroke	A	B	C	D	E
10 mm [0.394]	3.976	3.268	2.835	0.709	1.811
15 mm [0.591]	4.370	3.465	3.031	0.906	2.008
20 mm [0.787]	4.764	3.661	3.228	1.102	2.205
25 mm [0.984]	5.157	3.858	3.425	1.299	2.402
30 mm [1.181]	5.551	4.055	3.622	1.496	2.598

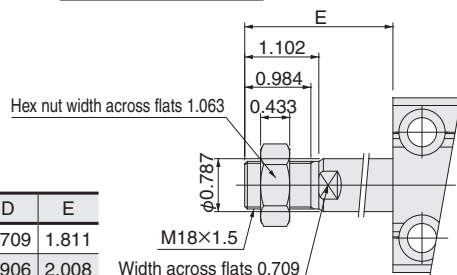

-B: Male thread specifications

-BK: With bracket (shipped attached)

Basic Cylinders

Double rod end cylinders



Symbol

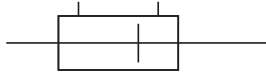

Specifications (standard, corrosion resistant specifications)

Item	Cylinder bore	6	8	10	12	16	20	25	32	40	50	63	80	100	125	
		[0.236]	[0.315]	[0.394]	[0.472]	[0.630]	[0.787]	[0.984]	[1.260]	[1.575]	[1.969]	[2.480]	[3.150]	[3.937]	[4.921]	
Operating type		Double acting type														
Medium		Air														
Operating pressure range	MPa [psi]	0.2 to 0.7 [29 to 102]			0.1 to 0.7 [15 to 102]			0.08 to 0.7 [12 to 102]								
Proof pressure	MPa [psi]	1.05 [152]														
Operating temperature range	°C [°F]	0 to 60 [32 to 140]														
Operating speed range	mm/s [in/sec]	50 to 500 [1.969 to 19.7]										50 to 300 [1.969 to 11.8]				
Cushion		Rubber bumper														
Lubrication		Not required														
Port size		M3×0.5			M5×0.8			Rc1/8			Rc1/4		Rc3/8			

Cylinder bore and stroke

Cylinder bore	Standard stroke
6, 8, 10, 12, 16 [0.236, 0.315, 0.394, 0.472, 0.630]	5, 10, 15, 20, 25, 30
20, 25 [0.787, 0.984]	5, 10, 15, 20, 25, 30, 40, 50
32, 40, 50, 63, 80, 100, 125 [1.260, 1.575, 1.969, 2.480, 3.150, 3.937, 4.921]	10, 20, 30, 40, 50, 60, 70, 75, 80, 90, 100

● Standard specifications

BC D X - - -

Number of sensor switches
 1 : 1 sensor switch
 2 : 2 sensor switches
 3 : 3 sensor switches
 ⋮

Bracket
 Blank : No bracket
 BK : With bracket^{Note 2}

Lead wire length
 A : 1000 mm [39 in]
 B : 3000 mm [118 in]
 G : 300 mm [11.8 in] with M8 connector, only on the ZE175, ZE177, ZE275, ZE277

Piston rod end shape
 Blank : Female thread^{Note 1}
 B : Male thread^{Note 1}
 BR : Rod side female thread
 Head side male thread
 BH : Rod side male thread
 Head side female thread

Sensor switch model
 Blank : No sensor switch
 ZE135 : 2-lead wires, solid state type, horizontal lead wires
 ZE155 : 3-lead wires, solid state NPN output type, horizontal lead wires
 ZE175 : 3-lead wires, solid state PNP output type, horizontal lead wires
 ZE235 : 2-lead wires, solid state type, vertical lead wires
 ZE255 : 3-lead wires, solid state NPN output type, vertical lead wires
 ZE275 : 3-lead wires, solid state PNP output type, vertical lead wires
 ZE137 : 2-lead wires, 2-color LED solid state type, horizontal lead wires
 ZE157 : 3-lead wires, 2-color LED solid state NPN output type, horizontal lead wires
 ZE177 : 3-lead wires, 2-color LED solid state PNP output type, horizontal lead wires
 ZE237 : 2-lead wires, 2-color LED solid state type, vertical lead wires
 ZE257 : 3-lead wires, 2-color LED solid state NPN output type, vertical lead wires
 ZE277 : 3-lead wires, 2-color LED solid state PNP output type, vertical lead wires
 ZE101 : 2-lead wires, reed switch type without indicator, horizontal lead wire^{Note 3}
 ZE102 : 2-lead wires, reed switch type, horizontal lead wire^{Note 3}
 ZE201 : 2-lead wires, reed switch type without indicator, vertical lead wire^{Note 3}
 ZE202 : 2-lead wires, reed switch type, vertical lead wire^{Note 3}

Cylinder bore
 X
Stroke
 ● See page 77 for cylinder bores and strokes.

D : Double acting double rod end type

Basic Cylinders

● For details on sensor switches, see page 100.

Note 1: The both rod ends are the same shape. When ends are not the same shape, select **-BR** or **-BH**.
 2: Brackets cannot be attached to cylinders that have $\phi 6$ [0.236] or $\phi 8$ [0.315] cylinder bores.
 3: Reed type sensor switches cannot be attached to cylinders that have $\phi 6$ [0.236], $\phi 8$ [0.315], $\phi 10$ [0.394], or $\phi 12$ [0.472] cylinder bores.

● Corrosion resistant specification (Change of material of piston rod, etc.)

BC D R X - - -

Number of sensor switches
 1 : 1 sensor switch
 2 : 2 sensor switches
 3 : 3 sensor switches
 ⋮

Bracket
 Blank : No bracket
 BK : With bracket^{Note 2}

Lead wire length
 A : 1000 mm [39 in]
 B : 3000 mm [118 in]
 G : 300 mm [11.8 in] with M8 connector, only on the ZE175, ZE177, ZE275, ZE277

Piston rod end shape
 Blank : Female thread^{Note 1}
 B : Male thread^{Note 1}
 BR : Rod side female thread
 Head side male thread
 BH : Rod side male thread
 Head side female thread

Sensor switch model
 Blank : No sensor switch
 ZE135 : 2-lead wires, solid state type, horizontal lead wires
 ZE155 : 3-lead wires, solid state NPN output type, horizontal lead wires
 ZE175 : 3-lead wires, solid state PNP output type, horizontal lead wires
 ZE235 : 2-lead wires, solid state type, vertical lead wires
 ZE255 : 3-lead wires, solid state NPN output type, vertical lead wires
 ZE275 : 3-lead wires, solid state PNP output type, vertical lead wires
 ZE137 : 2-lead wires, 2-color LED solid state type, horizontal lead wires
 ZE157 : 3-lead wires, 2-color LED solid state NPN output type, horizontal lead wires
 ZE177 : 3-lead wires, 2-color LED solid state PNP output type, horizontal lead wires
 ZE237 : 2-lead wires, 2-color LED solid state type, vertical lead wires
 ZE257 : 3-lead wires, 2-color LED solid state NPN output type, vertical lead wires
 ZE277 : 3-lead wires, 2-color LED solid state PNP output type, vertical lead wires
 ZE101 : 2-lead wires, reed switch type without indicator, horizontal lead wire^{Note 3}
 ZE102 : 2-lead wires, reed switch type, horizontal lead wire^{Note 3}
 ZE201 : 2-lead wires, reed switch type without indicator, vertical lead wire^{Note 3}
 ZE202 : 2-lead wires, reed switch type, vertical lead wire^{Note 3}

Cylinder bore
 X
Stroke
 ● See page 77 for cylinder bores and strokes.

R : Corrosion resistant specification

D : Double acting double rod end type

Basic Cylinders

● For details on sensor switches, see page 100.

Note 1: The both rod ends are the same shape. When ends are not the same shape, select **-BR** or **-BH**.
 2: Brackets cannot be attached to cylinders that have $\phi 6$ [0.236] or $\phi 8$ [0.315] cylinder bores.
 3: Reed type sensor switches cannot be attached to cylinders that have $\phi 6$ [0.236], $\phi 8$ [0.315], $\phi 10$ [0.394], or $\phi 12$ [0.472] cylinder bores.

Mass

● Double rod end cylinders

unit: g

Model	Stroke mm [in]													
	5 [0.197]	10 [0.394]	15 [0.591]	20 [0.787]	25 [0.984]	30 [1.181]	40 [1.575]	50 [1.969]	60 [2.362]	70 [2.756]	75 [2.953]	80 [3.150]	90 [3.543]	100 [3.9]
BCD6	16 (20)	19 (23)	22 (26)	25 (29)	28 (32)	31 (35)	—	—	—	—	—	—	—	—
BCD8	23 (27)	27 (31)	31 (35)	35 (39)	39 (43)	43 (47)	—	—	—	—	—	—	—	—
BCD10	25 (29)	29 (33)	33 (37)	37 (41)	41 (45)	45 (49)	—	—	—	—	—	—	—	—
BCD12	36 (42)	42 (48)	48 (54)	54 (60)	60 (66)	66 (72)	—	—	—	—	—	—	—	—
BCD16	55 (65)	63 (73)	71 (81)	79 (89)	87 (97)	95 (105)	—	—	—	—	—	—	—	—
BCD20	94 (114)	107 (127)	120 (140)	133 (153)	146 (166)	159 (179)	185 (205)	211 (231)	—	—	—	—	—	—
BCD25	137 (169)	154 (186)	171 (203)	188 (220)	205 (237)	222 (254)	256 (288)	290 (322)	—	—	—	—	—	—
BCD32	—	277 (357)	—	334 (414)	—	391 (471)	448 (528)	505 (585)	562 (642)	619 (699)	648 (728)	676 (756)	733 (813)	790 (870)
BCD40	—	383 (463)	—	446 (526)	—	509 (589)	572 (652)	635 (715)	698 (778)	761 (841)	793 (873)	824 (904)	887 (967)	950 (1030)
BCD50	—	690 (880)	—	786 (976)	—	882 (1072)	978 (1168)	1074 (1264)	1170 (1360)	1266 (1456)	1314 (1504)	1362 (1552)	1458 (1648)	1554 (1744)
BCD63	—	1016 (1206)	—	1122 (1312)	—	1228 (1418)	1334 (1524)	1440 (1630)	1546 (1736)	1652 (1842)	1705 (1895)	1758 (1948)	1864 (2054)	1970 (2160)
BCD80	—	1526 (1886)	—	1672 (2032)	—	1818 (2178)	1964 (2324)	2110 (2470)	2256 (2616)	2402 (2762)	2475 (2835)	2548 (2908)	2694 (3054)	2840 (3200)
BCD100	—	2520 (3120)	—	2745 (3345)	—	2970 (3570)	3195 (3795)	3420 (4020)	3645 (4245)	3870 (4470)	3983 (4583)	4095 (4695)	4320 (4920)	4545 (5145)
BCD125	—	4070 (5152)	—	4380 (5462)	—	4690 (5772)	5000 (6082)	5310 (6392)	5621 (6703)	5932 (7014)	6088 (7170)	6243 (7325)	6554 (7636)	6865 (7947)

Values in () parentheses are masses for male thread specifications

unit: oz

Model	Stroke mm [in]													
	5 [0.197]	10 [0.394]	15 [0.591]	20 [0.787]	25 [0.984]	30 [1.181]	40 [1.575]	50 [1.969]	60 [2.362]	70 [2.756]	75 [2.953]	80 [3.150]	90 [3.543]	100 [3.9]
BCD6	0.564 (0.705)	0.670 (0.811)	0.776 (0.917)	0.882 (1.023)	0.988 (1.129)	1.093 (1.235)	—	—	—	—	—	—	—	—
BCD8	0.811 (0.952)	0.952 (1.093)	1.093 (1.235)	1.235 (1.376)	1.376 (1.517)	1.517 (1.658)	—	—	—	—	—	—	—	—
BCD10	0.882 (1.023)	1.023 (1.164)	1.164 (1.305)	1.305 (1.446)	1.446 (1.587)	1.587 (1.728)	—	—	—	—	—	—	—	—
BCD12	1.270 (1.482)	1.482 (1.693)	1.693 (1.905)	1.905 (2.116)	2.116 (2.328)	2.328 (2.540)	—	—	—	—	—	—	—	—
BCD16	1.940 (2.293)	2.222 (2.575)	2.504 (2.857)	2.787 (3.139)	3.069 (3.422)	3.351 (3.7)	—	—	—	—	—	—	—	—
BCD20	3.316 (4.0)	3.8 (4.5)	4.2 (4.9)	4.7 (5.4)	5.1 (5.9)	5.6 (6.3)	6.5 (7.2)	7.4 (8.1)	—	—	—	—	—	—
BCD25	4.8 (6.0)	5.4 (6.6)	6 (7.2)	6.6 (7.8)	7.2 (8.4)	7.8 (9.0)	9.0 (10.2)	10.2 (11.4)	—	—	—	—	—	—
BCD32	—	9.8 (12.6)	—	11.8 (14.6)	—	13.8 (16.6)	15.8 (18.6)	17.8 (20.6)	19.8 (22.6)	21.8 (24.7)	22.9 (25.7)	23.8 (26.7)	25.9 (28.7)	27.9 (30.7)
BCD40	—	13.5 (16.3)	—	15.7 (18.6)	—	18.0 (20.8)	20.2 (23.0)	22.4 (25.2)	24.6 (27.4)	26.8 (29.7)	28.0 (30.8)	29.1 (31.9)	31.3 (34.1)	33.5 (36)
BCD50	—	24.3 (31)	—	27.7 (34.4)	—	31.1 (38)	34.5 (41)	38 (45)	41 (48)	45 (51)	46 (53)	48 (55)	51 (58)	55 (62)
BCD63	—	36 (43)	—	40 (46)	—	43 (50)	47 (54)	51 (57)	55 (61)	58 (65)	60 (67)	62 (69)	66 (72)	69 (76)
BCD80	—	54 (67)	—	59 (72)	—	64 (77)	69 (82)	74 (87)	80 (92)	85 (97)	87 (100)	90 (103)	95 (108)	100 (113)
BCD100	—	89 (110)	—	97 (118)	—	105 (126)	113 (134)	121 (142)	129 (150)	137 (158)	140 (162)	144 (166)	152 (174)	160 (181)
BCD125	—	144 (182)	—	154 (193)	—	165 (204)	176 (215)	187 (225)	198 (236)	209 (247)	215 (253)	220 (258)	231 (269)	242 (280)

Values in () parentheses are masses for male thread specifications

● Additional mass of sensor switches

ZE□A, ZE□G: 15 g [0.53 oz] ZE□B: 35 g [1.23 oz]

Internal construction (standard, corrosion resistant specifications)

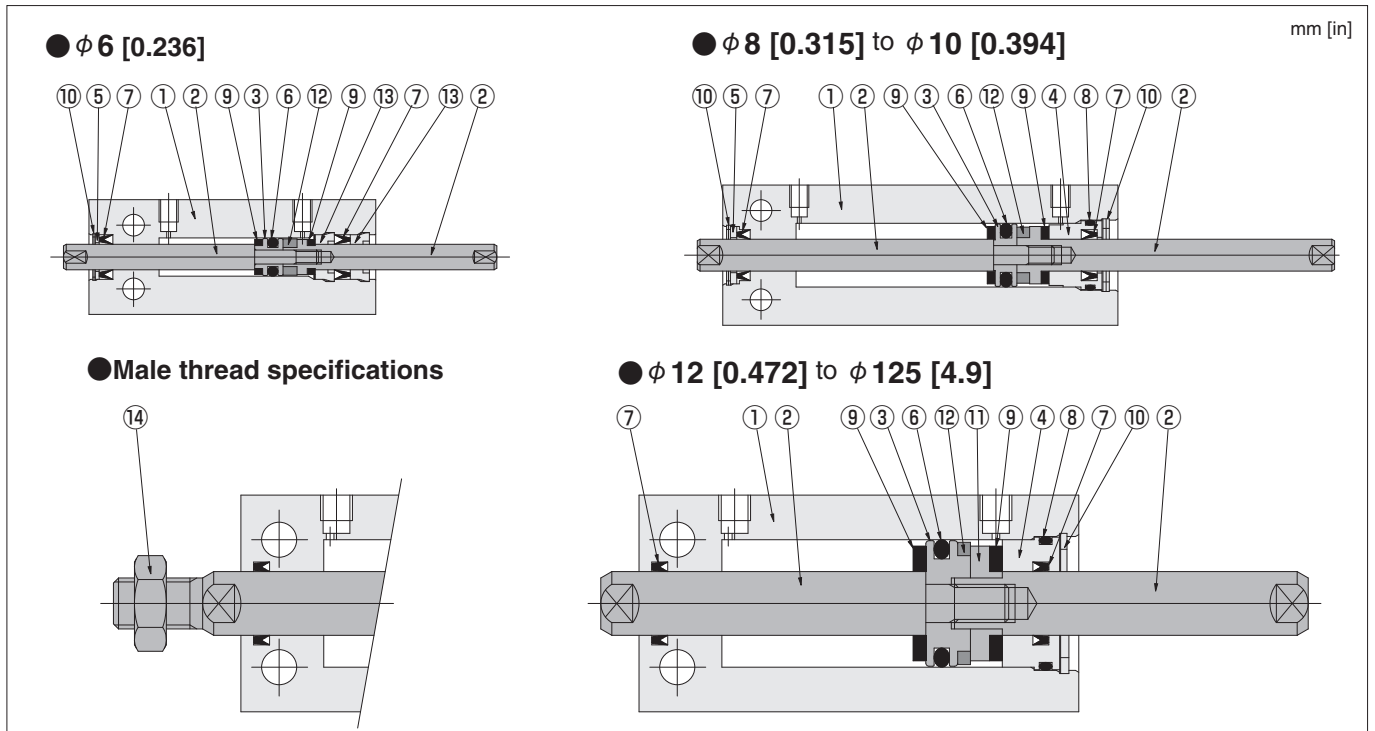

Major parts and materials

No.	Name	φ 6 [0.236]	φ 8 [0.315]	φ 10 [0.394]	φ 12 [0.472]	φ 16 [0.630]	φ 20 [0.787]	φ 25 [0.984]	φ 32 [1.260]	φ 40 [1.575]	φ 50 [1.969]	φ 63 [2.480]	φ 80 [3.150]	φ 100 [3.937]	φ 125 [4.9]	
①	Cylinder body	Aluminum alloy (special anti-abrasion treated)														
②	Piston rod	Stainless steel							Carbon steel (Heat resistant specification is stainless steel.)							
③	Piston	Stainless steel					Aluminum alloy (anodized)									
④	Head cover	Aluminum alloy (anodized)														
⑤	Seal holder	Aluminum alloy (anodized)	—	—	—	—	—	—	—	—	—	—	—	—	—	
⑥	★ Piston seal	Synthetic rubber (NBR)														
⑦	★ Rod seal	Synthetic rubber (NBR)														
⑧	★ O-ring	Synthetic rubber (NBR)														
⑨	Bumper	Urethane rubber	Synthetic rubber (NBR)													
⑩	★ Retaining ring	Stainless steel			Steel (Corrosion resistant specification is electroless nickel plated.)											
⑪	Support	Stainless steel			Aluminum alloy (anodized)											
⑫	Magnet	Neodymium magnet							Plastic magnet							
⑬	Rod cap	Polyacetal	—	—	—	—	—	—	—	—	—	—	—	—	—	
⑭	Rod end nut	Carbon steel (Heat resistant specification is stainless steel.)														

Items indicated by a ★ are available as additional parts or in packing sets. For order codes, see page 80.

Double acting double rod end type dimensions

unit: mm

- BCD6
- BCDR6 (corrosion resistant specification)

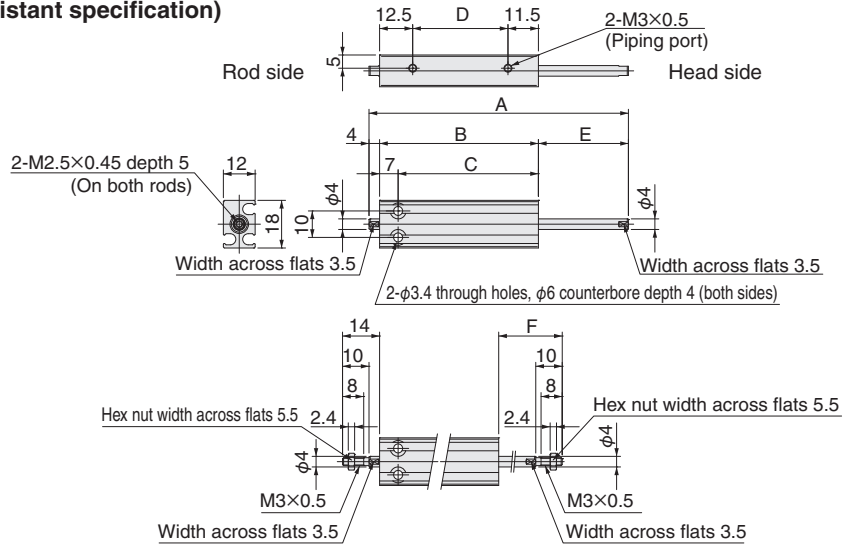

-B: Male thread specifications

Stroke	A	B	C	D	E	F
5	48	35	28	11	9	19
10	58	40	33	16	14	24
15	68	45	38	21	19	29
20	78	50	43	26	24	34
25	88	55	48	31	29	39
30	98	60	53	36	34	44

Remarks -BR: Rod side female thread, head side male thread specification.
 -BH: Rod side male thread, head side female thread specification.
 Calculated dimensions referring to the female and male thread dimensions in the above diagram.

Note: This product cannot use reed switch type sensor switches.

- BCD8
- BCDR8 (corrosion resistant specification)

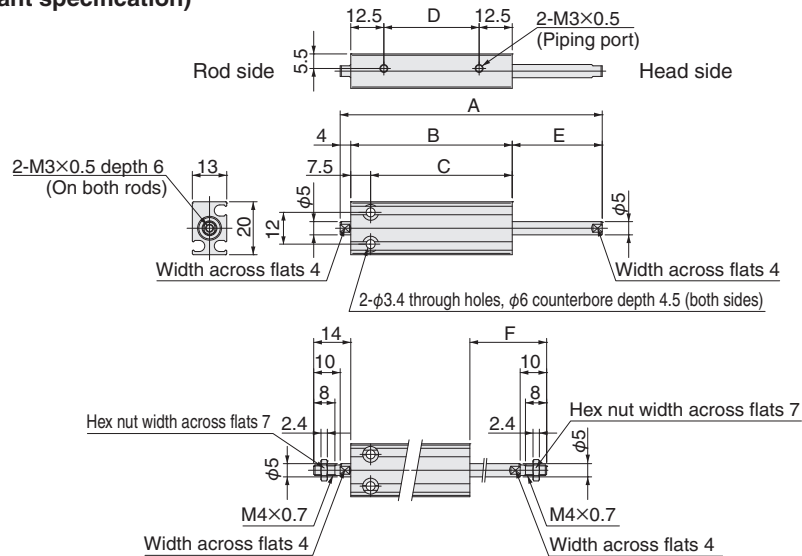

-B: Male thread specifications

Stroke	A	B	C	D	E	F
5	49	36	28.5	11	9	19
10	59	41	33.5	16	14	24
15	69	46	38.5	21	19	29
20	79	51	43.5	26	24	34
25	89	56	48.5	31	29	39
30	99	61	53.5	36	34	44

Remarks -BR: Rod side female thread, head side male thread specification.
 -BH: Rod side male thread, head side female thread specification.
 Calculated dimensions referring to the female and male thread dimensions in the above diagram.

Note: This product cannot use reed switch type sensor switches.

- BCD6
- BCDR6 (corrosion resistant specification)

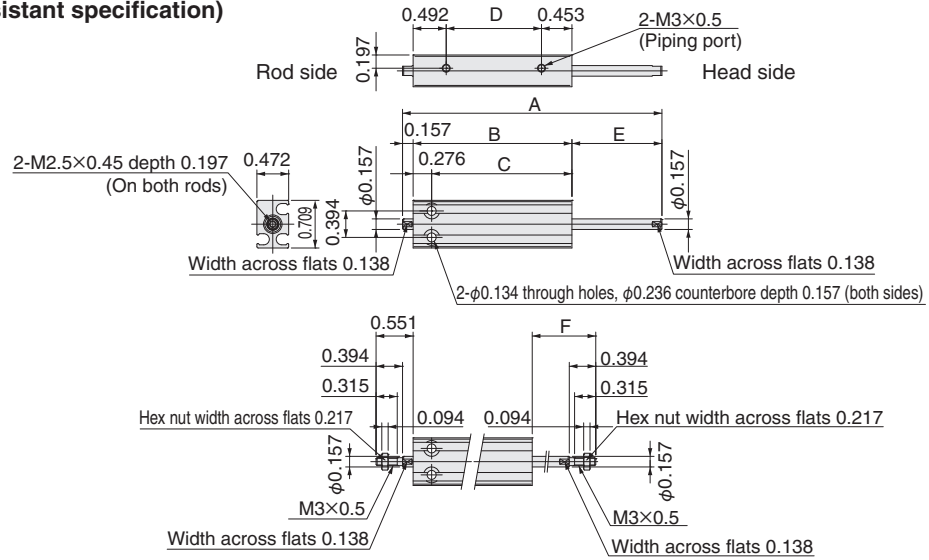

-B: Male thread specifications

Remarks

-BR: Rod side female thread, head side male thread specification.
 -BH: Rod side male thread, head side female thread specification.
 Calculated dimensions referring to the female and male thread dimensions in the above diagram.

Stroke	A	B	C	D	E	F
5 mm [0.197]	1.890	1.378	1.102	0.433	0.354	0.748
10 mm [0.394]	2.283	1.575	1.299	0.630	0.551	0.945
15 mm [0.591]	2.677	1.772	1.496	0.827	0.748	1.142
20 mm [0.787]	3.071	1.969	1.693	1.024	0.945	1.339
25 mm [0.984]	3.465	2.165	1.890	1.220	1.142	1.535
30 mm [1.181]	3.858	2.362	2.087	1.417	1.339	1.732

Note: This product cannot use reed switch type sensor switches.

- BCD8
- BCDR8 (corrosion resistant specification)

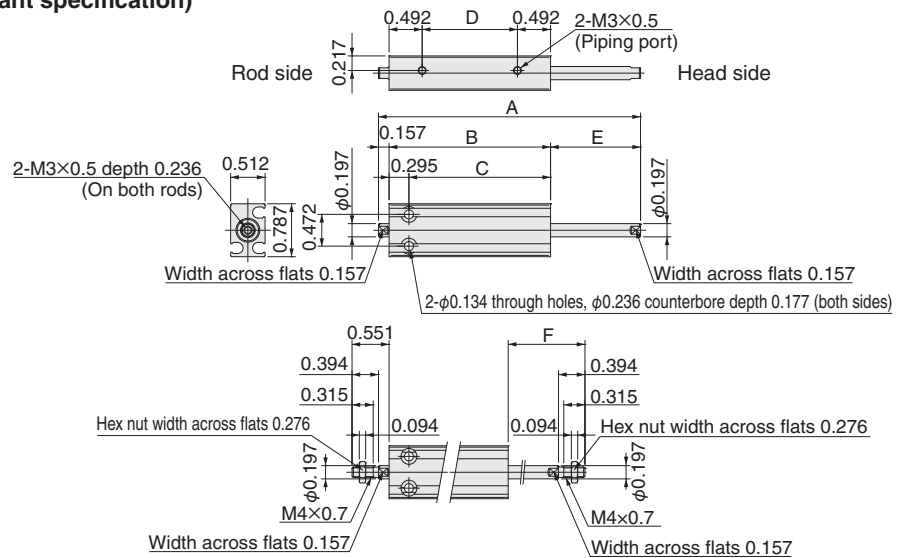

-B: Male thread specifications

Remarks

-BR: Rod side female thread, head side male thread specification.
 -BH: Rod side male thread, head side female thread specification.
 Calculated dimensions referring to the female and male thread dimensions in the above diagram.

Stroke	A	B	C	D	E	F
5 mm [0.197]	1.929	1.417	1.122	0.433	0.354	0.748
10 mm [0.394]	2.323	1.614	1.319	0.630	0.551	0.945
15 mm [0.591]	2.717	1.811	1.516	0.827	0.748	1.142
20 mm [0.787]	3.110	2.008	1.713	1.024	0.945	1.339
25 mm [0.984]	3.504	2.205	1.909	1.220	1.142	1.535
30 mm [1.181]	3.898	2.402	2.106	1.417	1.339	1.732

Note: This product cannot use reed switch type sensor switches.

Double acting double rod end type dimensions

unit: mm

- BCD10
- BCDR10 (corrosion resistant specification)

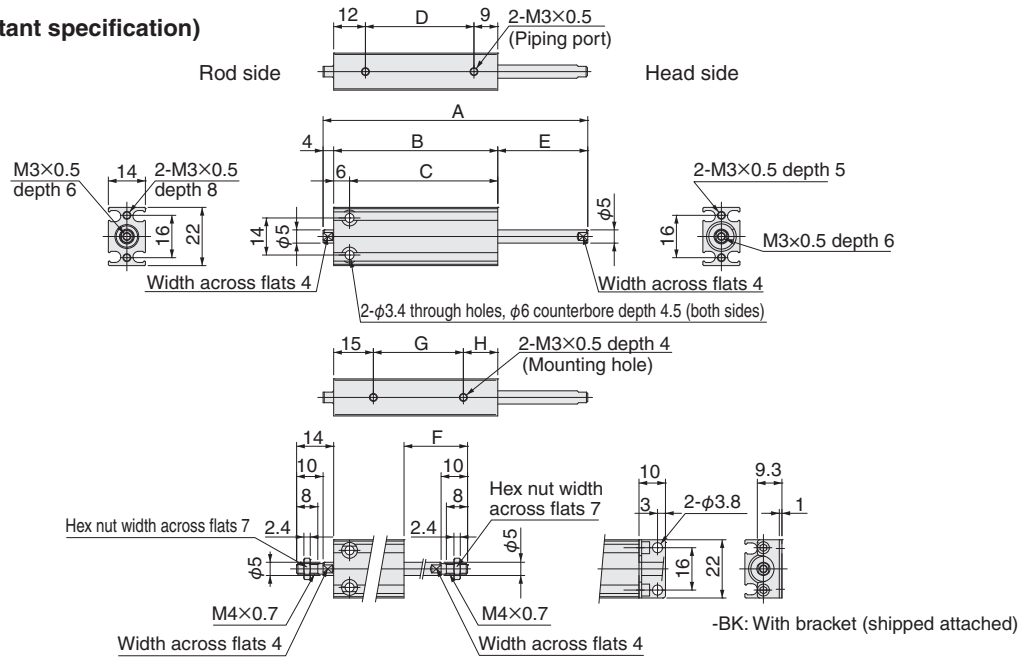

Stroke	A	B	C	D	E	F	G	H
5	50	37	31	16	9	19	10	12
10	60	42	36	21	14	24	10	17
15	70	47	41	26	19	29	20	12
20	80	52	46	31	24	34	20	17
25	90	57	51	36	29	39	30	12
30	100	62	56	41	34	44	30	17

-B: Male thread specifications

Remarks
-BR: Rod side female thread, head side male thread specification.
-BH: Rod side male thread, head side female thread specification.
 Calculated dimensions referring to the female and male thread dimensions in the above diagram.

Note: This product cannot use reed switch type sensor switches.

- BCD12
- BCDR12 (corrosion resistant specification)

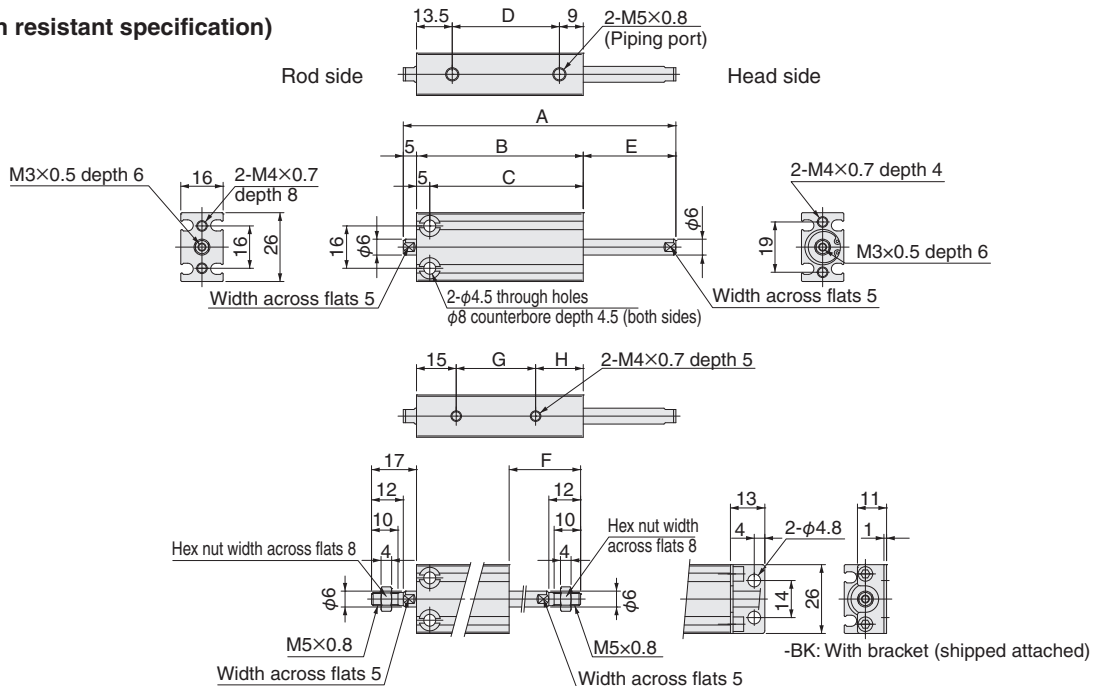

-B: Male thread specifications

Remarks
-BR: Rod side female thread, head side male thread specification.
-BH: Rod side male thread, head side female thread specification.
 Calculated dimensions referring to the female and male thread dimensions in the above diagram.

Note: This product cannot use reed switch type sensor switches.

Stroke	A	B	C	D	E	F	G	H
5	53	38	33	15.5	10	22	10	13
10	63	43	38	20.5	15	27	10	18
15	73	48	43	25.5	20	32	20	13
20	83	53	48	30.5	25	37	20	18
25	93	58	53	35.5	30	42	30	13
30	103	63	58	40.5	35	47	30	18

Double acting double rod end type dimensions

unit: in

- BCD10
- BCDR10 (corrosion resistant specification)

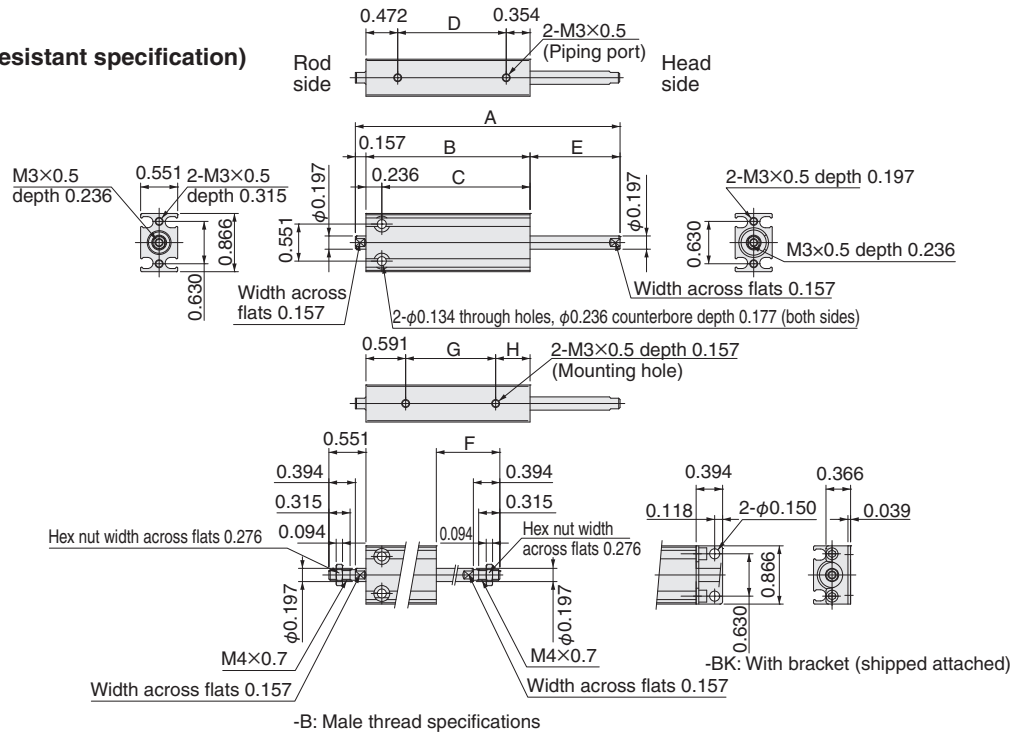

Stroke	A	B	C	D	E	F	G	H
5 mm [0.197]	1.969	1.457	1.220	0.630	0.354	0.748	0.394	0.472
10 mm [0.394]	2.362	1.654	1.417	0.827	0.551	0.945	0.394	0.669
15 mm [0.591]	2.756	1.850	1.614	1.024	0.748	1.142	0.787	0.472
20 mm [0.787]	3.150	2.047	1.811	1.220	0.945	1.339	0.787	0.669
25 mm [0.984]	3.543	2.244	2.008	1.417	1.142	1.535	1.181	0.472
30 mm [1.181]	3.937	2.441	2.205	1.614	1.339	1.732	1.181	0.669

Remarks -BR: Rod side female thread, head side male thread specification.
 -BH: Rod side male thread, head side female thread specification.
 Calculated dimensions referring to the female and male thread dimensions in the above diagram.

Note: This product cannot use reed switch type sensor switches.

- BCD12
- BCDR12 (corrosion resistant specification)

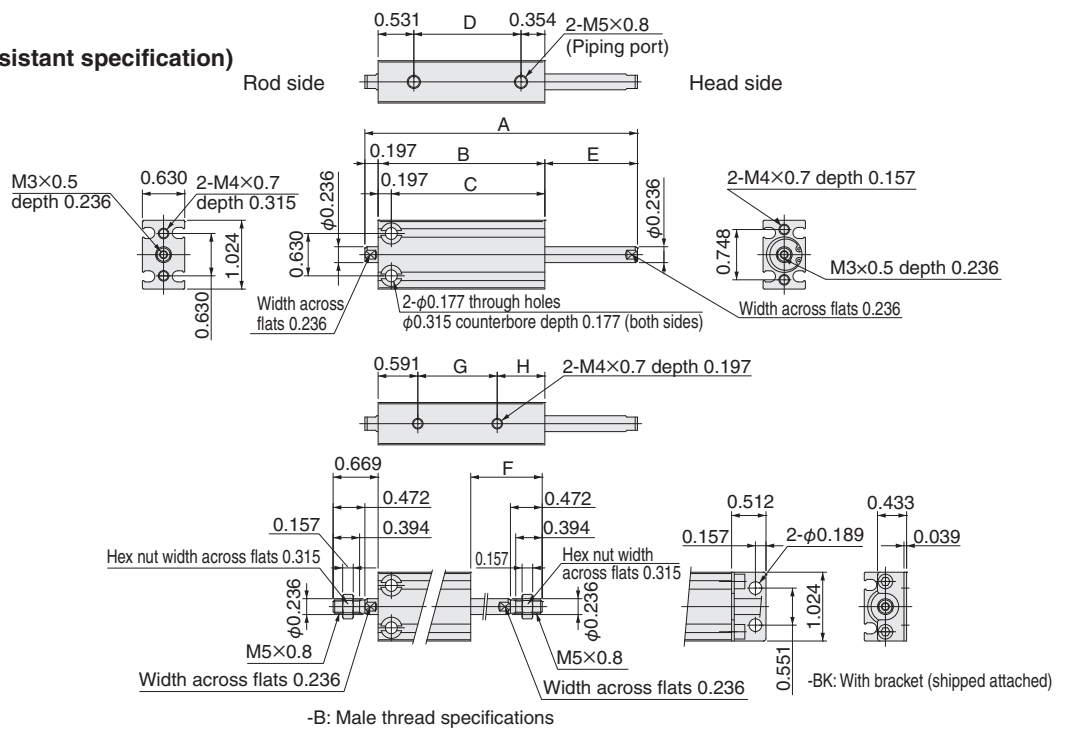

Stroke	A	B	C	D	E	F	G	H
5 mm [0.197]	2.087	1.496	1.299	0.610	0.394	0.866	0.394	0.512
10 mm [0.394]	2.480	1.693	1.496	0.807	0.591	1.063	0.394	0.709
15 mm [0.591]	2.874	1.890	1.693	1.004	0.787	1.260	0.787	0.512
20 mm [0.787]	3.268	2.087	1.890	1.201	0.984	1.457	0.787	0.709
25 mm [0.984]	3.661	2.283	2.087	1.398	1.181	1.654	1.181	0.512
30 mm [1.181]	4.055	2.480	2.283	1.594	1.378	1.850	1.181	0.709

Remarks -BR: Rod side female thread, head side male thread specification.
 -BH: Rod side male thread, head side female thread specification.
 Calculated dimensions referring to the female and male thread dimensions in the above diagram.

Note: This product cannot use reed switch type sensor switches.

Double acting double rod end type dimensions

unit: mm

- BCD16
- BCDR16 (corrosion resistant specification)

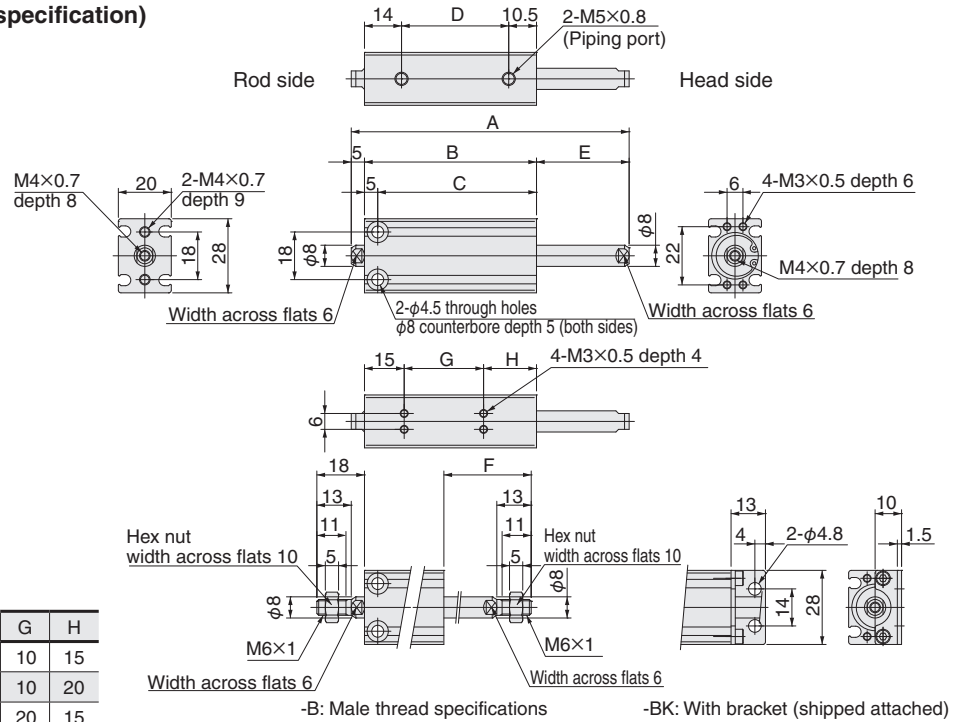

Stroke	A	B	C	D	E	F	G	H
5	55	40	35	15.5	10	23	10	15
10	65	45	40	20.5	15	28	10	20
15	75	50	45	25.5	20	33	20	15
20	85	55	50	30.5	25	38	20	20
25	95	60	55	35.5	30	43	30	15
30	105	65	60	40.5	35	48	30	20

Remarks

- BR: Rod side female thread, head side male thread specification.
- BH: Rod side male thread, head side female thread specification.

Calculated dimensions referring to the female and male thread dimensions in the above diagram.

- BCD20
- BCDR20 (corrosion resistant specification)

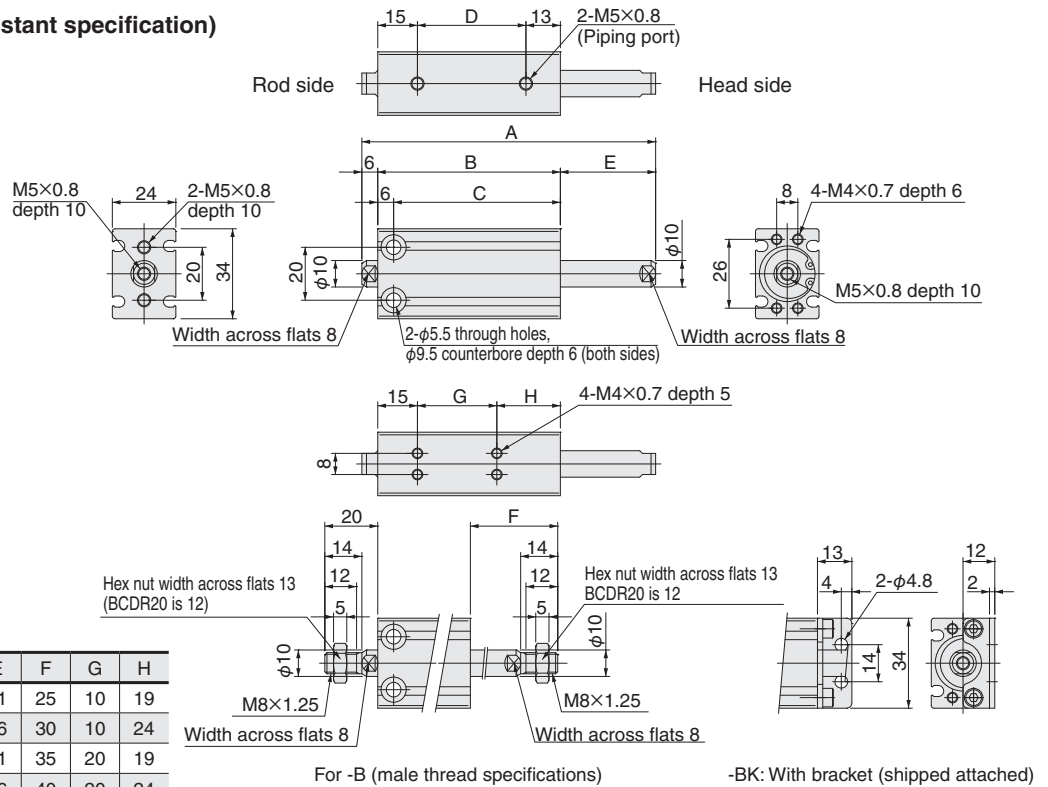

Stroke	A	B	C	D	E	F	G	H
5	61	44	38	16	11	25	10	19
10	71	49	43	21	16	30	10	24
15	81	54	48	26	21	35	20	19
20	91	59	53	31	26	40	20	24
25	101	64	58	36	31	45	30	19
30	111	69	63	41	36	50	30	24
40	131	79	73	51	46	60	40	24
50	151	89	83	61	56	70	50	24

Remarks

- BR: Rod side female thread, head side male thread specification.
- BH: Rod side male thread, head side female thread specification.

Calculated dimensions referring to the female and male thread dimensions in the above diagram.

Double acting double rod end type dimensions

unit: in

- BCD16
- BCDR16 (corrosion resistant specification)

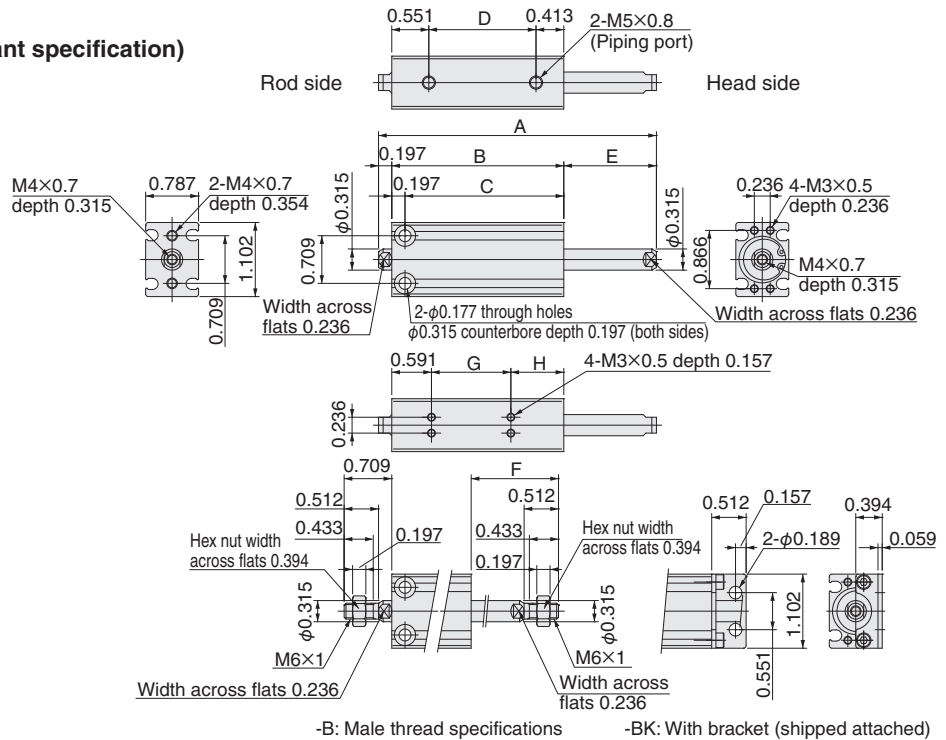

Stroke	A	B	C	D	E	F	G	H
5 mm [0.197]	2.165	1.575	1.378	0.610	0.394	0.906	0.394	0.591
10 mm [0.394]	2.559	1.772	1.575	0.807	0.591	1.102	0.394	0.787
15 mm [0.591]	2.953	1.969	1.772	1.004	0.787	1.299	0.787	0.591
20 mm [0.787]	3.346	2.165	1.969	1.201	0.984	1.496	0.787	0.787
25 mm [0.984]	3.740	2.362	2.165	1.398	1.181	1.693	1.181	0.591
30 mm [1.181]	4.134	2.559	2.362	1.594	1.378	1.890	1.181	0.787

Remarks -BR: Rod side female thread, head side male thread specification.
 -BH: Rod side male thread, head side female thread specification.
 Calculated dimensions referring to the female and male thread dimensions in the above diagram.

- BCD20
- BCDR20 (corrosion resistant specification)

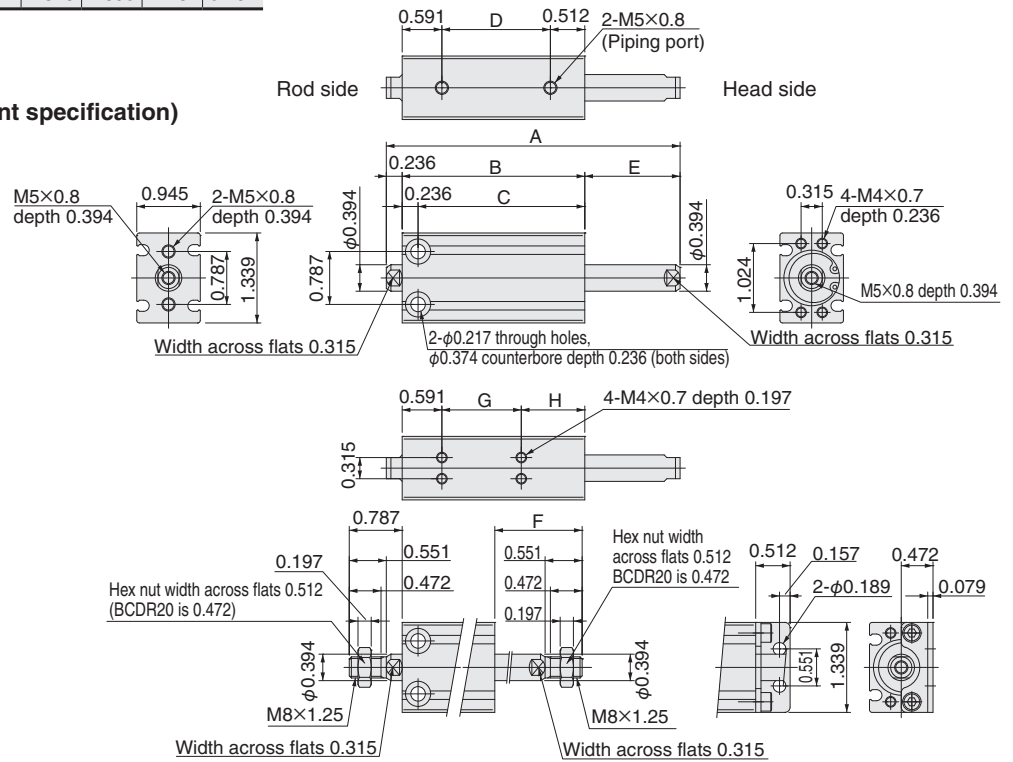

Stroke	A	B	C	D	E	F	G	H
5 mm [0.197]	2.402	1.732	1.496	0.630	0.433	0.984	0.394	0.748
10 mm [0.394]	2.795	1.929	1.693	0.827	0.630	1.181	0.394	0.945
15 mm [0.591]	3.189	2.126	1.890	1.024	0.827	1.378	0.787	0.748
20 mm [0.787]	3.583	2.323	2.087	1.220	1.024	1.575	0.787	0.945
25 mm [0.984]	3.976	2.520	2.283	1.417	1.220	1.772	1.181	0.748
30 mm [1.181]	4.370	2.717	2.480	1.614	1.417	1.969	1.181	0.945
40 mm [1.575]	5.157	3.110	2.874	2.008	1.811	2.362	1.575	0.945
50 mm [1.969]	5.945	3.504	3.268	2.402	2.205	2.756	1.969	0.945

Remarks -BR: Rod side female thread, head side male thread specification.
 -BH: Rod side male thread, head side female thread specification.
 Calculated dimensions referring to the female and male thread dimensions in the above diagram.

Double acting double rod end type dimensions

unit: mm

- BCD25
- BCDR25 (corrosion resistant specification)

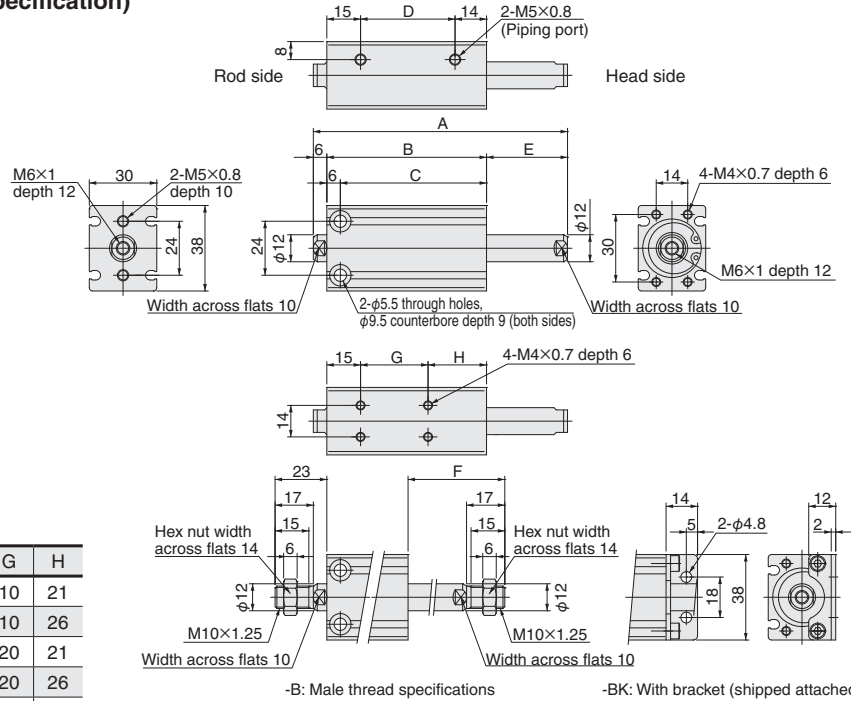

Stroke	A	B	C	D	E	F	G	H
5	63	46	40	17	11	28	10	21
10	73	51	45	22	16	33	10	26
15	83	56	50	27	21	38	20	21
20	93	61	55	32	26	43	20	26
25	103	66	60	37	31	48	30	21
30	113	71	65	42	36	53	30	26
40	133	81	75	52	46	63	40	26
50	153	91	85	62	56	73	50	26

Remarks -BR: Rod side female thread, head side male thread specification.
 -BH: Rod side male thread, head side female thread specification.
 Calculated dimensions referring to the female and male thread dimensions in the above diagram.

- BCD32
- BCDR32 (corrosion resistant specification)

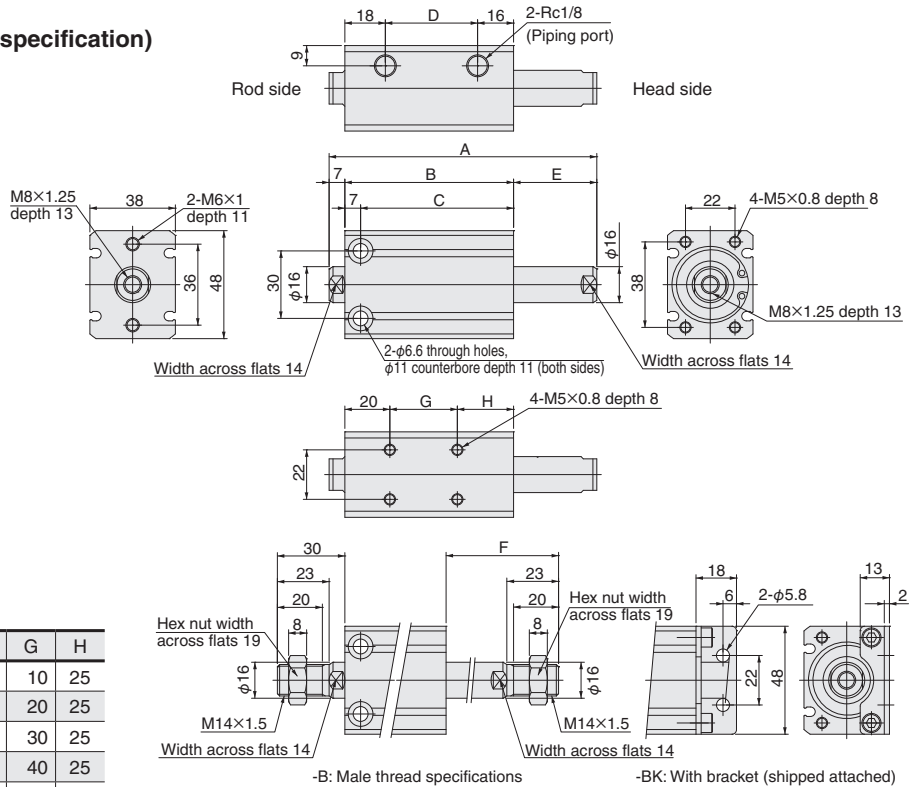

Stroke	A	B	C	D	E	F	G	H
10	79	55	48	21	17	40	10	25
20	99	65	58	31	27	50	20	25
30	119	75	68	41	37	60	30	25
40	139	85	78	51	47	70	40	25
50	159	95	88	61	57	80	50	25
60	179	105	98	71	67	90	50	35
70	199	115	108	81	77	100	70	25
75	209	120	113	86	82	105	80	20
80	219	125	118	91	87	110	80	25
90	239	135	128	101	97	120	80	35
100	259	145	138	111	107	130	100	25

Remarks -BR: Rod side female thread, head side male thread specification.
 -BH: Rod side male thread, head side female thread specification.
 Calculated dimensions referring to the female and male thread dimensions in the above diagram.

Double acting double rod end type dimensions

unit: in

- BCD25
- BCDR25 (corrosion resistant specification)

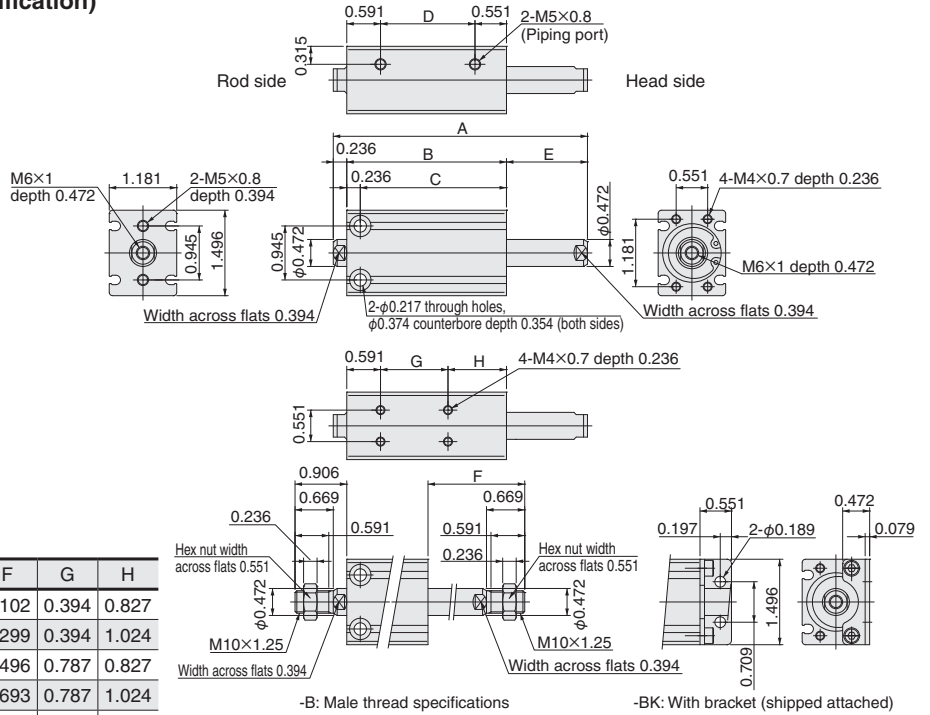

Stroke	A	B	C	D	E	F	G	H
5 mm [0.197]	2.480	1.811	1.575	0.669	0.433	1.102	0.394	0.827
10 mm [0.394]	2.874	2.008	1.772	0.866	0.630	1.299	0.394	1.024
15 mm [0.591]	3.268	2.205	1.969	1.063	0.827	1.496	0.787	0.827
20 mm [0.787]	3.661	2.402	2.165	1.260	1.024	1.693	0.787	1.024
25 mm [0.984]	4.055	2.598	2.362	1.457	1.220	1.890	1.181	0.827
30 mm [1.181]	4.449	2.795	2.559	1.654	1.417	2.087	1.181	1.024
40 mm [1.575]	5.236	3.189	2.953	2.047	1.811	2.480	1.575	1.024
50 mm [1.969]	6.024	3.583	3.346	2.441	2.205	2.874	1.969	1.024

Remarks -BR: Rod side female thread, head side male thread specification.
 -BH: Rod side male thread, head side female thread specification.
 Calculated dimensions referring to the female and male thread dimensions in the above diagram.

- BCD32
- BCDR32 (corrosion resistant specification)

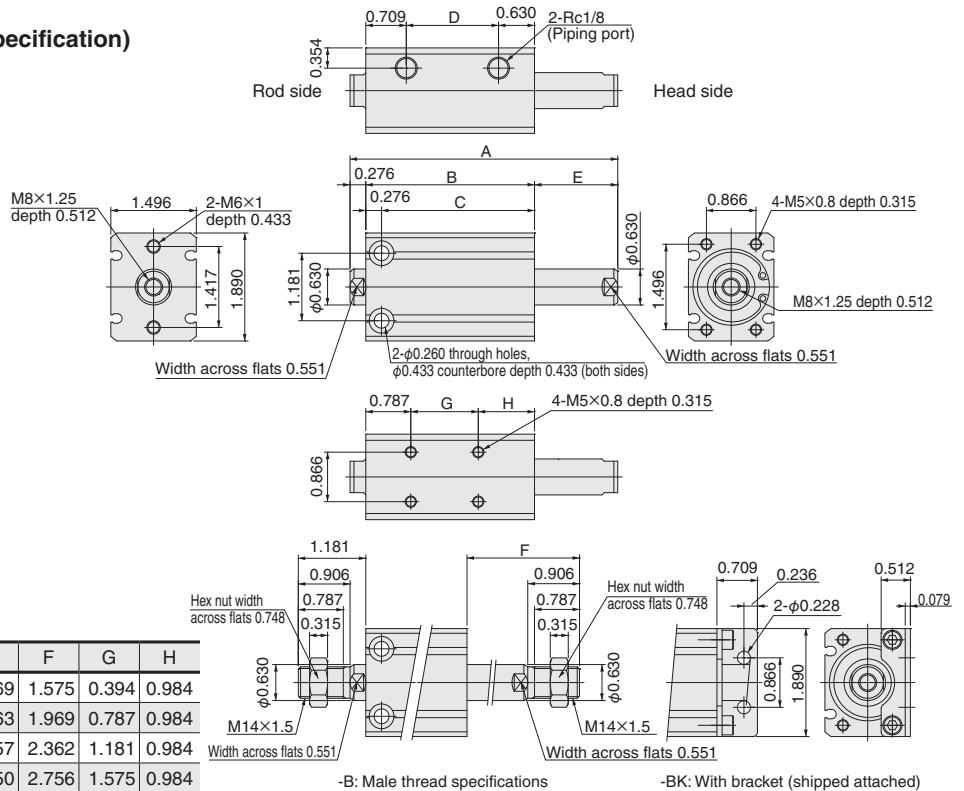

Stroke	A	B	C	D	E	F	G	H
10 mm [0.394]	3.110	2.165	1.890	0.827	0.669	1.575	0.394	0.984
20 mm [0.787]	3.898	2.559	2.283	1.220	1.063	1.969	0.787	0.984
30 mm [1.181]	4.685	2.953	2.677	1.614	1.457	2.362	1.181	0.984
40 mm [1.575]	5.472	3.346	3.071	2.008	1.850	2.756	1.575	0.984
50 mm [1.969]	6.260	3.740	3.465	2.402	2.244	3.150	1.969	0.984
60 mm [2.362]	7.047	4.134	3.858	2.795	2.638	3.543	1.969	1.378
70 mm [2.756]	7.835	4.528	4.252	3.189	3.031	3.937	2.756	0.984
75 mm [2.953]	8.228	4.724	4.449	3.386	3.228	4.134	3.150	0.787
80 mm [3.150]	8.622	4.921	4.646	3.583	3.425	4.331	3.150	0.984
90 mm [3.543]	9.409	5.315	5.039	3.976	3.819	4.724	3.150	1.378
100 mm [3.937]	10.197	5.709	5.433	4.370	4.213	5.118	3.937	0.984

Remarks -BR: Rod side female thread, head side male thread specification.
 -BH: Rod side male thread, head side female thread specification.
 Calculated dimensions referring to the female and male thread dimensions in the above diagram.

Double acting double rod end type dimensions

unit: mm

- BCD40
- BCDR40 (corrosion resistant specification)

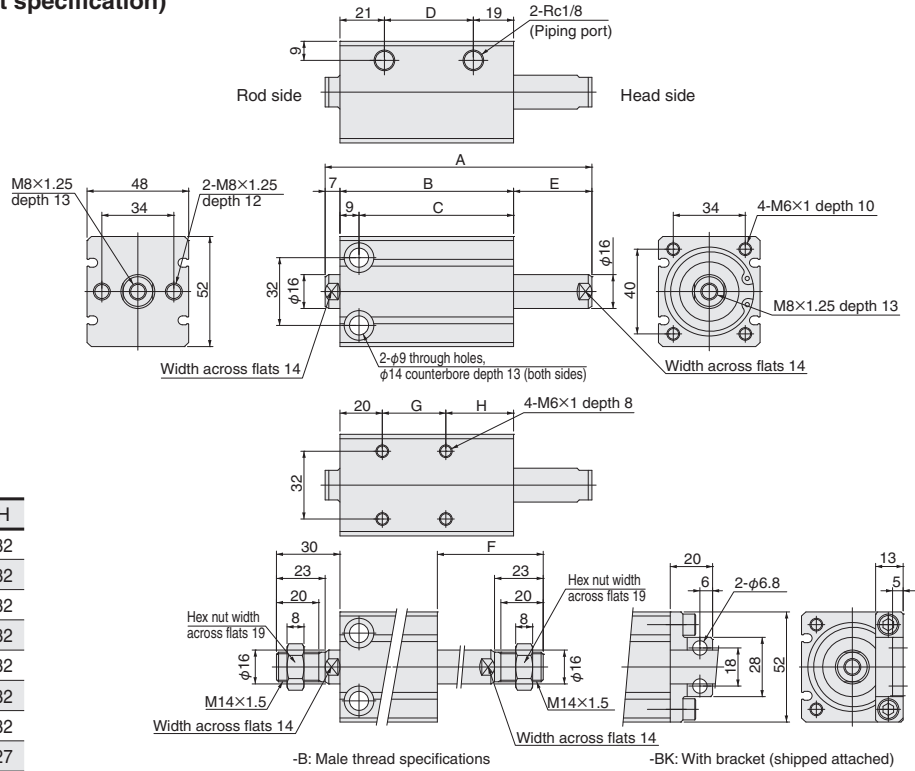

Stroke	A	B	C	D	E	F	G	H
10	86	62	53	22	17	40	15	32
20	106	72	63	32	27	50	20	32
30	126	82	73	42	37	60	30	32
40	146	92	83	52	47	70	40	32
50	166	102	93	62	57	80	50	32
60	186	112	103	72	67	90	60	32
70	206	122	113	82	77	100	70	32
75	216	127	118	87	82	105	80	27
80	226	132	123	92	87	110	80	32
90	246	142	133	102	97	120	80	42
100	266	152	143	112	107	130	100	32

Remarks -BR: Rod side female thread, head side male thread specification.
 -BH: Rod side male thread, head side female thread specification.
 Calculated dimensions referring to the female and male thread dimensions in the above diagram.

- BCD50
- BCDR50 (corrosion resistant specification)

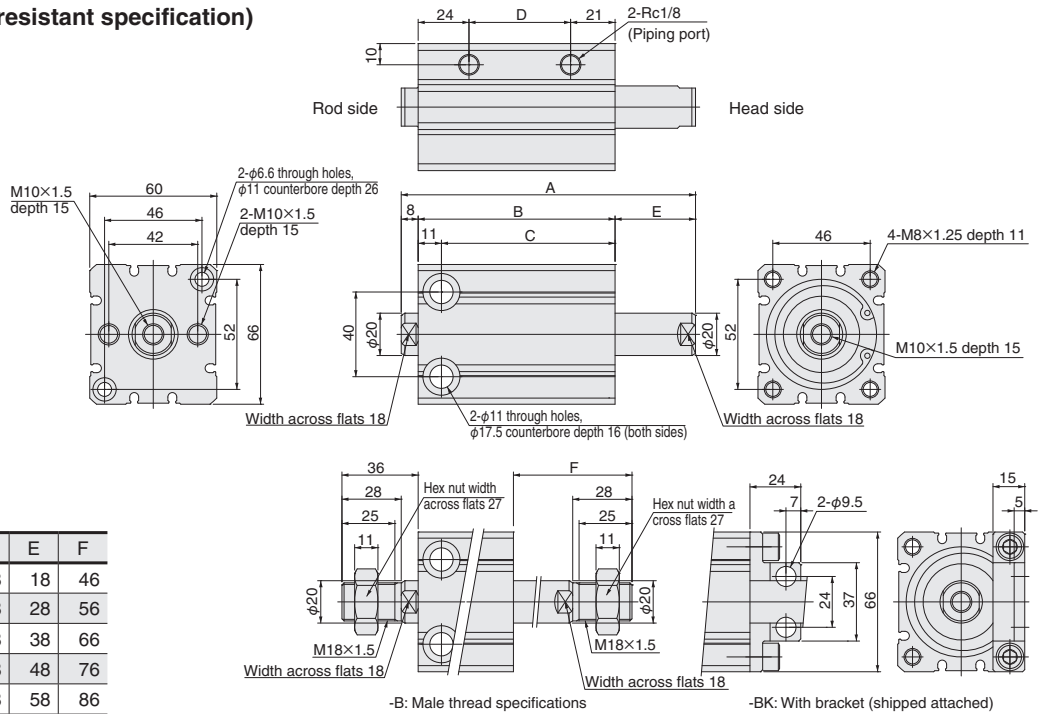

Stroke	A	B	C	D	E	F
10	99	73	62	28	18	46
20	119	83	72	38	28	56
30	139	93	82	48	38	66
40	159	103	92	58	48	76
50	179	113	102	68	58	86
60	199	123	112	78	68	96
70	219	133	122	88	78	106
75	229	138	127	93	83	111
80	239	143	132	98	88	116
90	259	153	142	108	98	126
100	279	163	152	118	108	136

Remarks -BR: Rod side female thread, head side male thread specification.
 -BH: Rod side male thread, head side female thread specification.
 Calculated dimensions referring to the female and male thread dimensions in the above diagram.

Double acting double rod end type dimensions

unit: in

- BCD40
- BCDR40 (corrosion resistant specification)

Stroke	A	B	C	D	E	F	G	H
10 mm [0.394]	3.386	2.441	2.087	0.866	0.669	1.575	0.591	1.260
20 mm [0.787]	4.173	2.835	2.480	1.260	1.063	1.969	0.787	1.260
30 mm [1.181]	4.961	3.228	2.874	1.654	1.457	2.362	1.181	1.260
40 mm [1.575]	5.748	3.622	3.268	2.047	1.850	2.756	1.575	1.260
50 mm [1.969]	6.535	4.016	3.661	2.441	2.244	3.150	1.969	1.260
60 mm [2.362]	7.323	4.409	4.055	2.835	2.638	3.543	2.362	1.260
70 mm [2.756]	8.110	4.803	4.449	3.228	3.031	3.937	2.756	1.260
75 mm [2.953]	8.504	5.000	4.646	3.425	3.228	4.134	3.150	1.063
80 mm [3.150]	8.898	5.197	4.843	3.622	3.425	4.331	3.150	1.260
90 mm [3.543]	9.685	5.591	5.236	4.016	3.819	4.724	3.150	1.654
100 mm [3.937]	10.472	5.984	5.630	4.409	4.213	5.118	3.937	1.260

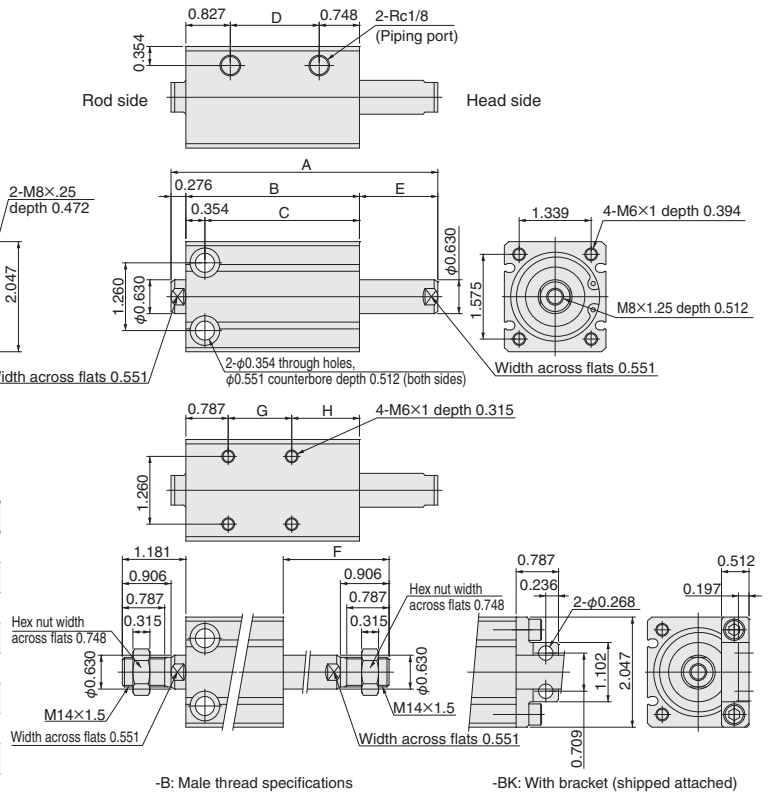

Remarks -B: Male thread specifications
 -BK: With bracket (shipped attached)
 -BR: Rod side female thread, head side male thread specification.
 -BH: Rod side male thread, head side female thread specification.
 Calculated dimensions referring to the female and male thread dimensions in the above diagram.

- BCD50
- BCDR50 (corrosion resistant specification)

Stroke	A	B	C	D	E	F
10 mm [0.394]	3.898	2.874	2.441	1.102	0.709	1.811
20 mm [0.787]	4.685	3.268	2.835	1.496	1.102	2.205
30 mm [1.181]	5.472	3.661	3.228	1.890	1.496	2.598
40 mm [1.575]	6.260	4.055	3.622	2.283	1.890	2.992
50 mm [1.969]	7.047	4.449	4.016	2.677	2.283	3.386
60 mm [2.362]	7.835	4.843	4.409	3.071	2.677	3.780
70 mm [2.756]	8.622	5.236	4.803	3.465	3.071	4.173
75 mm [2.953]	9.016	5.433	5.000	3.661	3.268	4.370
80 mm [3.150]	9.409	5.630	5.197	3.858	3.465	4.567
90 mm [3.543]	10.197	6.024	5.591	4.252	3.858	4.961
100 mm [3.937]	10.984	6.417	5.984	4.646	4.252	5.354

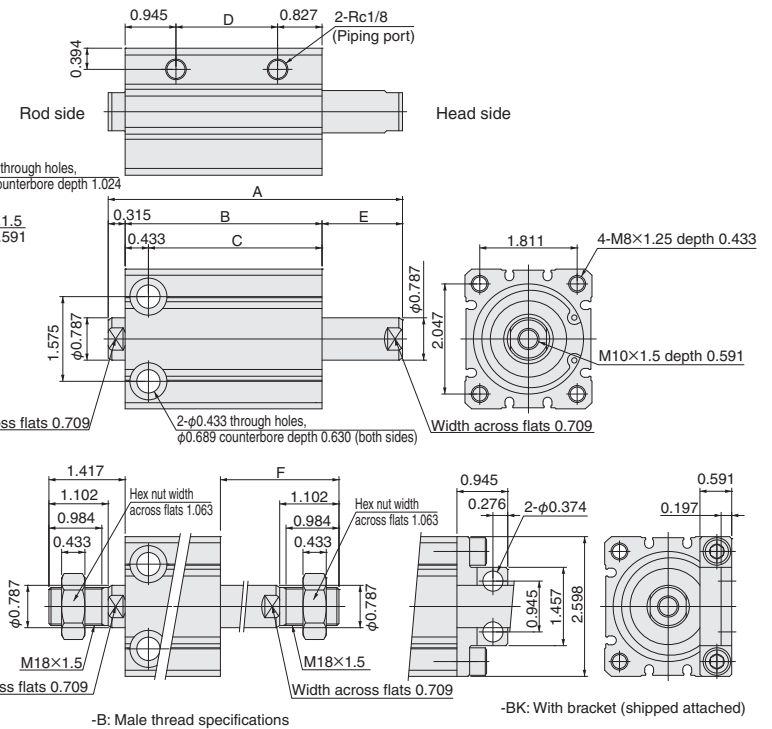

Remarks -B: Male thread specifications
 -BK: With bracket (shipped attached)
 -BR: Rod side female thread, head side male thread specification.
 -BH: Rod side male thread, head side female thread specification.
 Calculated dimensions referring to the female and male thread dimensions in the above diagram.

Double acting double rod end type dimensions

unit: mm

- BCD63
- BCDR63 (corrosion resistant specification)

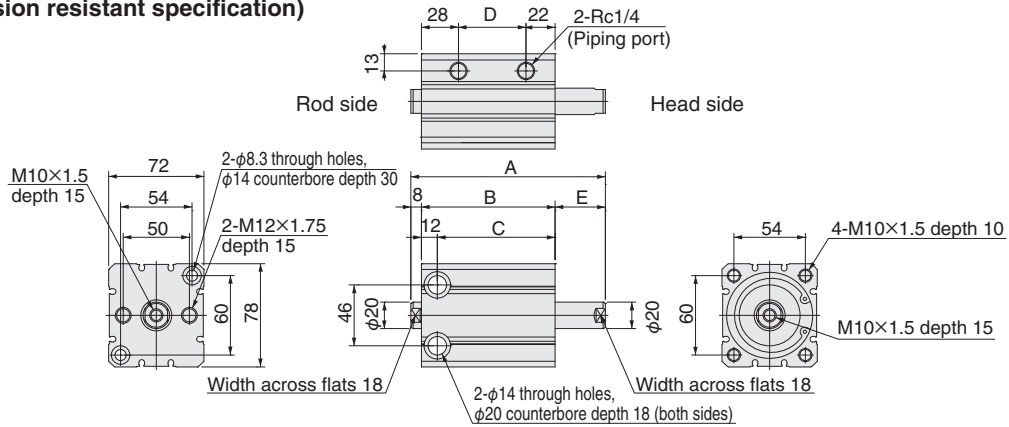

Stroke	A	B	C	D	E	F
10	107	81	69	31	18	46
20	127	91	79	41	28	56
30	147	101	89	51	38	66
40	167	111	99	61	48	76
50	187	121	109	71	58	86
60	207	131	119	81	68	96
70	227	141	129	91	78	106
75	237	146	134	96	83	111
80	247	151	139	101	88	116
90	267	161	149	111	98	126
100	287	171	159	121	108	136

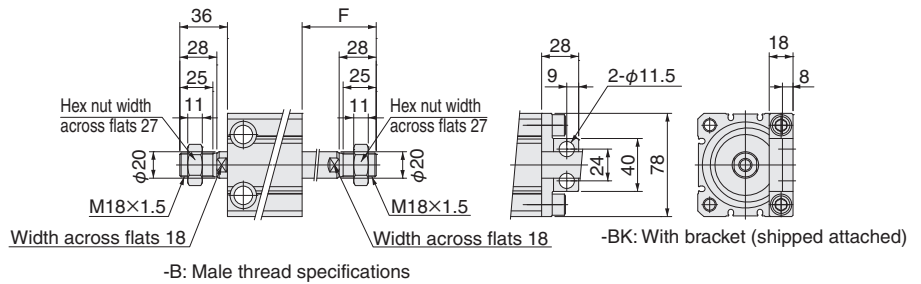

Remarks -B: Male thread specifications
 -BR: Rod side female thread, head side male thread specification.
 -BH: Rod side male thread, head side female thread specification.
 Calculated dimensions referring to the female and male thread dimensions in the above diagram.

- BCD80
- BCDR80 (corrosion resistant specification)

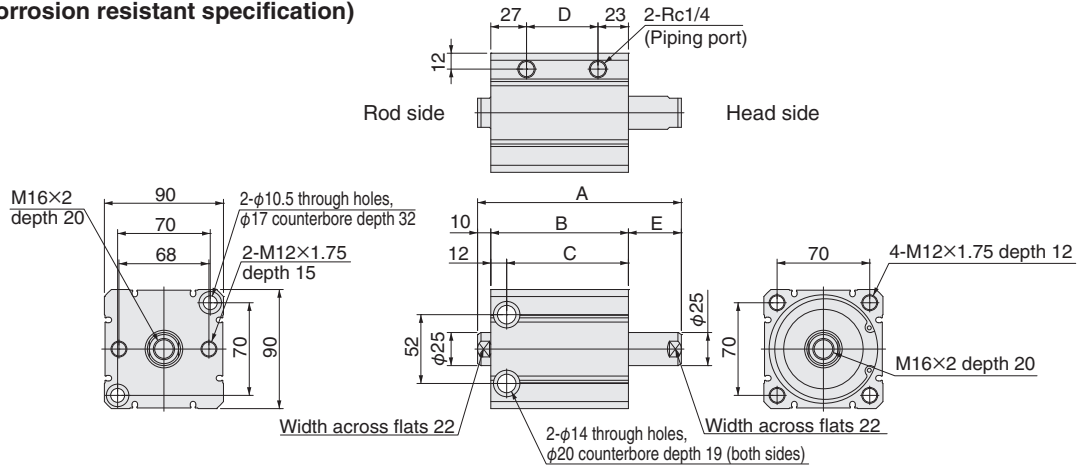

Stroke	A	B	C	D	E	F
10	114	84	72	34	20	53
20	134	94	82	44	30	63
30	154	104	92	54	40	73
40	174	114	102	64	50	83
50	194	124	112	74	60	93
60	214	134	122	84	70	103
70	234	144	132	94	80	113
75	244	149	137	99	85	118
80	254	154	142	104	90	123
90	274	164	152	114	100	133
100	294	174	162	124	110	143

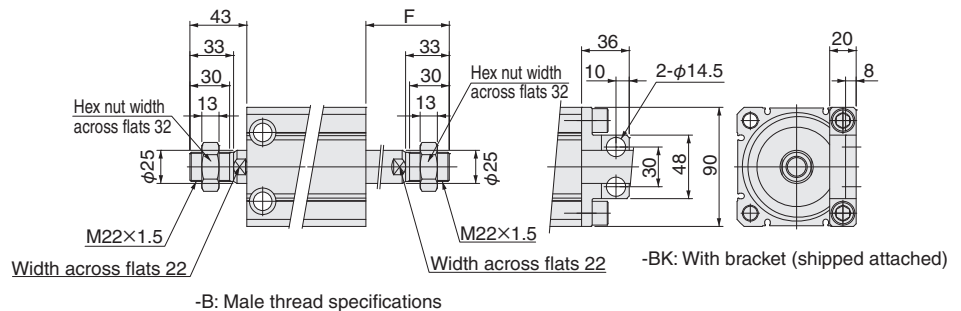

Remarks -B: Male thread specifications
 -BR: Rod side female thread, head side male thread specification.
 -BH: Rod side male thread, head side female thread specification.
 Calculated dimensions referring to the female and male thread dimensions in the above diagram.

Double acting double rod end type dimensions

unit: in

- BCD63
- BCDR63 (corrosion resistant specification)

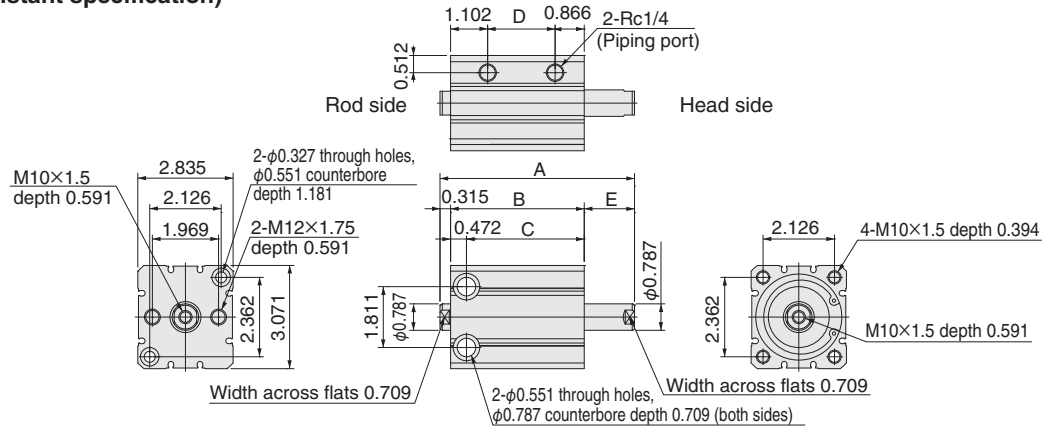

Stroke	A	B	C	D	E	F
10 mm [0.394]	4.213	3.189	2.717	1.220	0.709	1.811
20 mm [0.787]	5.000	3.583	3.110	1.614	1.102	2.205
30 mm [1.181]	5.787	3.976	3.504	2.008	1.496	2.598
40 mm [1.575]	6.575	4.370	3.898	2.402	1.890	2.992
50 mm [1.969]	7.362	4.764	4.291	2.795	2.283	3.386
60 mm [2.362]	8.150	5.157	4.685	3.189	2.677	3.780
70 mm [2.756]	8.937	5.551	5.079	3.583	3.071	4.173
75 mm [2.953]	9.331	5.748	5.276	3.780	3.268	4.370
80 mm [3.150]	9.724	5.945	5.472	3.976	3.465	4.567
90 mm [3.543]	10.512	6.339	5.866	4.370	3.858	4.961
100 mm [3.937]	11.299	6.732	6.260	4.764	4.252	5.354

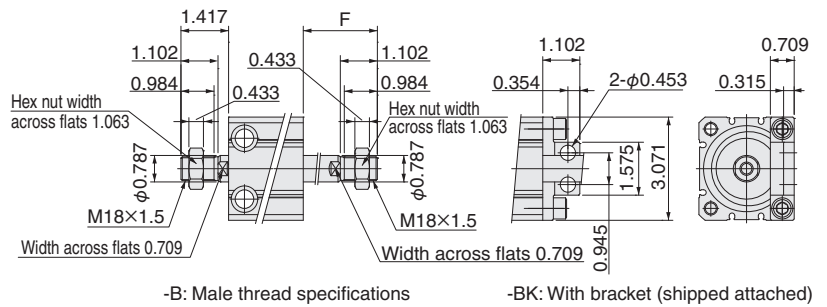

Remark -BR: Rod side female thread, head side male thread specification.
 -BH: Rod side male thread, head side female thread specification.
 Calculated dimensions referring to the female and male thread dimensions in the above diagram.

- BCD80
- BCDR80 (corrosion resistant specification)

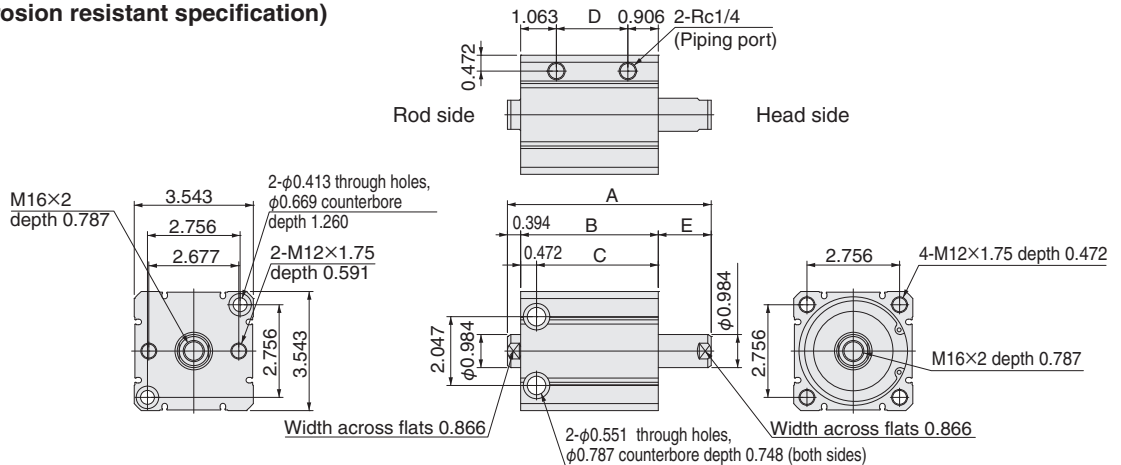

Stroke	A	B	C	D	E	F
10 mm [0.394]	4.488	3.307	2.835	1.339	0.787	2.087
20 mm [0.787]	5.276	3.701	3.228	1.732	1.181	2.480
30 mm [1.181]	6.063	4.094	3.622	2.126	1.575	2.874
40 mm [1.575]	6.850	4.488	4.016	2.520	1.969	3.268
50 mm [1.969]	7.638	4.882	4.409	2.913	2.362	3.661
60 mm [2.362]	8.425	5.276	4.803	3.307	2.756	4.055
70 mm [2.756]	9.213	5.669	5.197	3.701	3.150	4.449
75 mm [2.953]	9.606	5.866	5.394	3.898	3.346	4.646
80 mm [3.150]	10.000	6.063	5.591	4.094	3.543	4.843
90 mm [3.543]	10.787	6.457	5.984	4.488	3.937	5.236
100 mm [3.937]	11.575	6.850	6.378	4.882	4.331	5.630

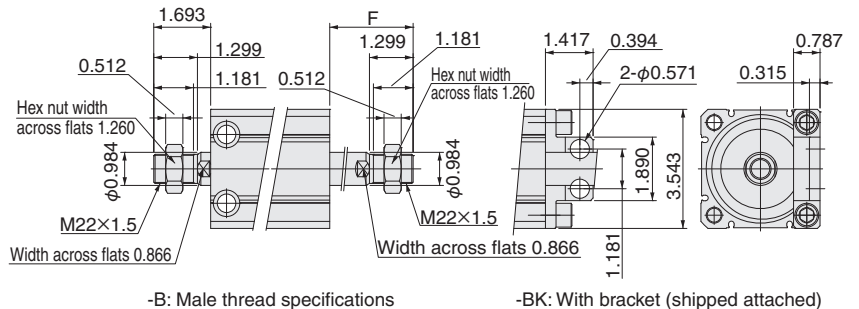

Remark -BR: Rod side female thread, head side male thread specification.
 -BH: Rod side male thread, head side female thread specification.
 Calculated dimensions referring to the female and male thread dimensions in the above diagram.

Double acting double rod end type dimensions

unit: mm

- BCD100
- BCDR100 (corrosion resistant specification)

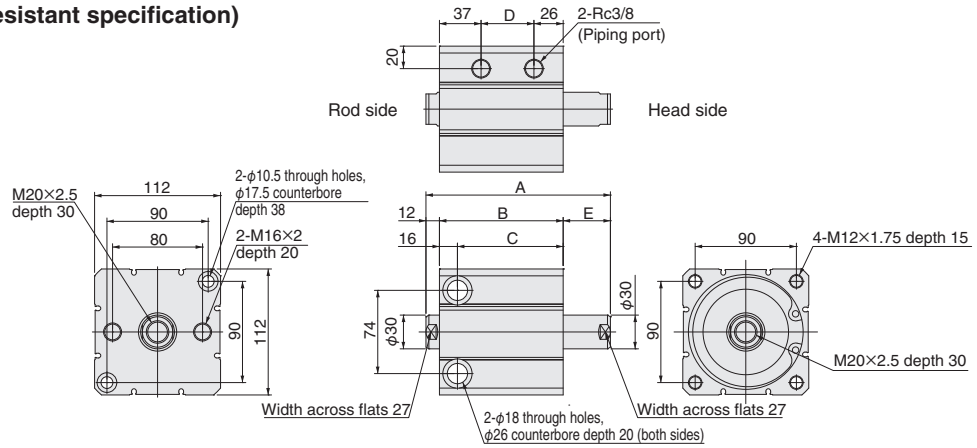

Stroke	A	B	C	D	E	F
10	124	90	74	27	22	60
20	144	100	84	37	32	70
30	164	110	94	47	42	80
40	184	120	104	57	52	90
50	204	130	114	67	62	100
60	224	140	124	77	72	110
70	244	150	134	87	82	120
75	254	155	139	92	87	125
80	264	160	144	97	92	130
90	284	170	154	107	102	140
100	304	180	164	117	112	150

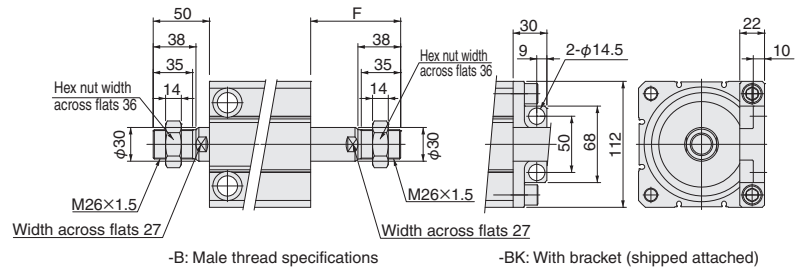

Remarks -BR: Rod side female thread, head side male thread specification.
 -BH: Rod side male thread, head side female thread specification.
 Calculated dimensions referring to the female and male thread dimensions in the above diagram.

- BCD125
- BCDR125 (corrosion resistant specification)

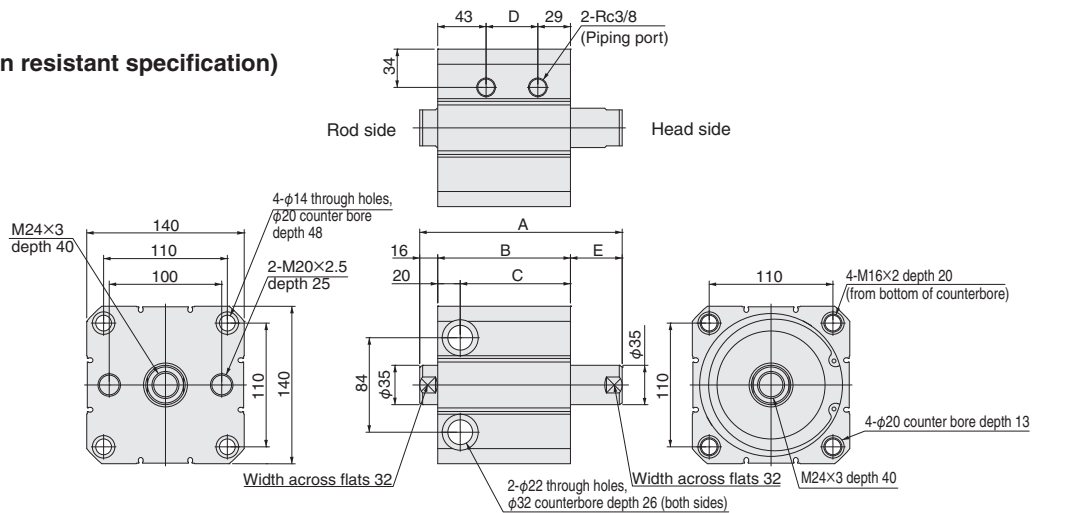

Stroke	A	B	C	D	E	F
10	140	98	78	26	26	70
20	160	108	88	36	36	80
30	180	118	98	46	46	90
40	200	128	108	56	56	100
50	220	138	118	66	66	110
60	240	148	128	76	76	120
70	260	158	138	86	86	130
75	270	163	143	91	91	135
80	280	168	148	96	96	140
90	300	178	158	106	106	150
100	320	188	168	116	116	160

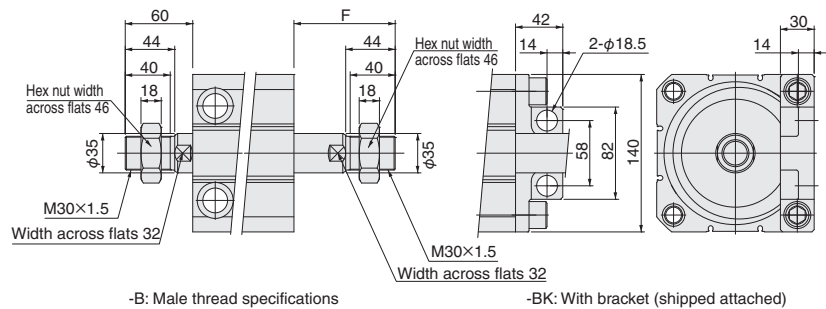

Remarks -BR: Rod side female thread, head side male thread specification.
 -BH: Rod side male thread, head side female thread specification.
 Calculated dimensions referring to the female and male thread dimensions in the above diagram.

Double acting double rod end type dimensions

unit: in

- BCD100
- BCDR100 (corrosion resistant specification)

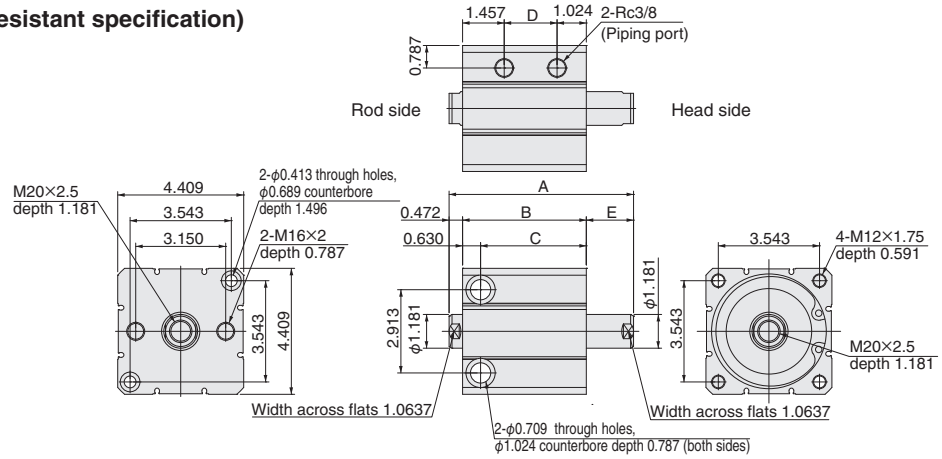

Stroke	A	B	C	D	E	F
10 mm [0.394]	4.882	3.543	2.913	1.063	0.866	2.362
20 mm [0.787]	5.669	3.937	3.307	1.457	1.260	2.756
30 mm [1.181]	6.457	4.331	3.701	1.850	1.654	3.150
40 mm [1.575]	7.244	4.724	4.094	2.244	2.047	3.543
50 mm [1.969]	8.031	5.118	4.488	2.638	2.441	3.937
60 mm [2.362]	8.819	5.512	4.882	3.031	2.835	4.331
70 mm [2.756]	9.606	5.906	5.276	3.425	3.228	4.724
75 mm [2.953]	10.000	6.102	5.472	3.622	3.425	4.921
80 mm [3.150]	10.394	6.299	5.669	3.819	3.622	5.118
90 mm [3.543]	11.181	6.693	6.063	4.213	4.016	5.512
100 mm [3.937]	11.969	7.087	6.457	4.606	4.409	5.906

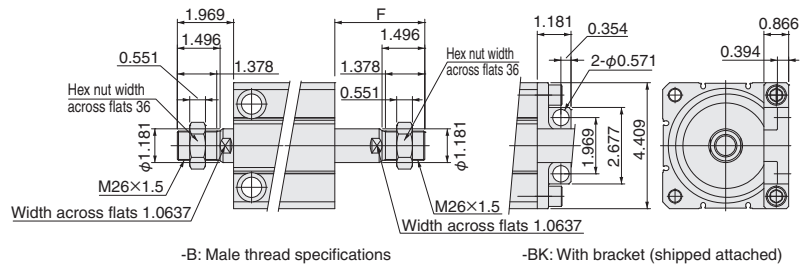

Remark -BR: Rod side female thread, head side male thread specification.
 -BH: Rod side male thread, head side female thread specification.
 Calculated dimensions referring to the female and male thread dimensions in the above diagram.

- BCD125
- BCDR125 (corrosion resistant specification)

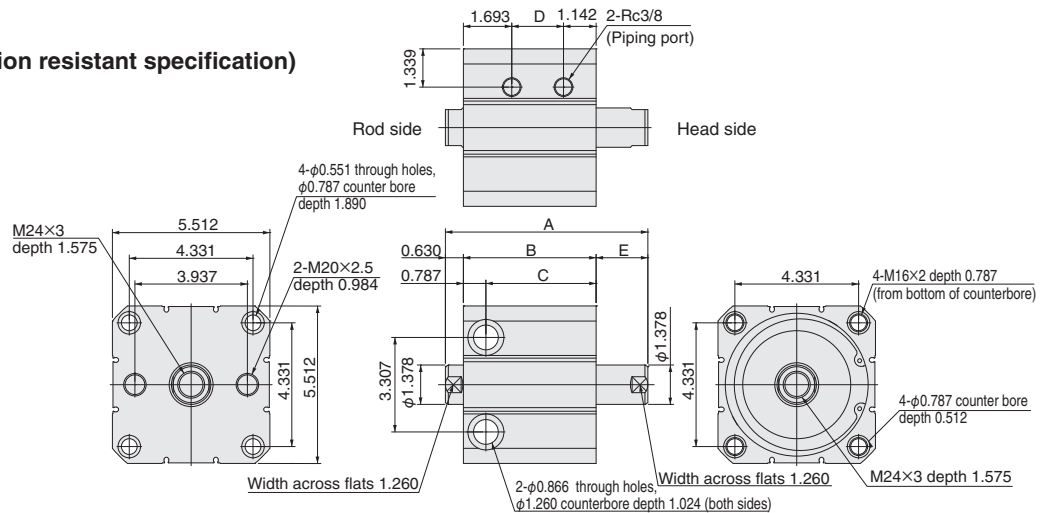

Stroke	A	B	C	D	E	F
10 mm [0.394]	5.512	3.858	3.071	1.024	1.024	2.756
20 mm [0.787]	6.299	4.252	3.465	1.417	1.417	3.150
30 mm [1.181]	7.087	4.646	3.858	1.811	1.811	3.543
40 mm [1.575]	7.874	5.039	4.252	2.205	2.205	3.937
50 mm [1.969]	8.661	5.433	4.646	2.598	2.598	4.331
60 mm [2.362]	9.449	5.827	5.039	2.992	2.992	4.724
70 mm [2.756]	10.236	6.220	5.433	3.386	3.386	5.118
75 mm [2.953]	10.630	6.417	5.630	3.583	3.583	5.315
80 mm [3.150]	11.024	6.614	5.827	3.780	3.780	5.512
90 mm [3.543]	11.811	7.008	6.220	4.173	4.173	5.906
100 mm [3.937]	12.598	7.402	6.614	4.567	4.567	6.299

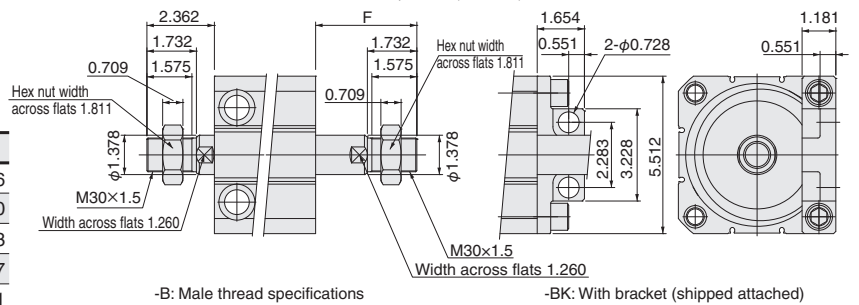

Remark -BR: Rod side female thread, head side male thread specification.
 -BH: Rod side male thread, head side female thread specification.
 Calculated dimensions referring to the female and male thread dimensions in the above diagram.

Basic Cylinders

Cylinder with guide

Symbol

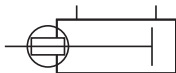

Specifications (standard, corrosion resistant, heat resistant specifications)

Item	Cylinder bore	8 [0.315]	12 [0.472]	16 [0.630]	20 [0.787]	25 [0.984]	32 [1.260]	40 [1.575]
Operating type		Double acting type						
Medium		Air						
Operating pressure range MPa [psi]	Standard, corrosion resistant specifications	0.2 to 0.7 [29 to 102]	0.1 to 0.7 [15 to 102]		0.08 to 0.7 [12 to 102]			
	Heat resistant specification	0.25 to 0.7 [36 to 102]	0.15 to 0.7 [22 to 102]					
Proof pressure	MPa [psi]	1.05 [152]						
Operating temperature range	°C [°F]	0 to 60 [32 to 140] (0 to 150 [32 to 302] for heat resistant specification ^{Note})						
Operating speed range	mm/s [in/sec]	50 to 500 [1.969 to 19.7] (100 to 300 [3.9 to 11.8] for heat resistant specification)						
Cushion		Rubber bumper						
Lubrication		Not required						
Port size		M3×0.5	M5×0.8				Rc1/8	
Running parallelism	mm [in]	0.1 [0.004] or less						
Allowable moment N·m [in·lbf]	Pitching	0.12 [1.062] (0.11 [0.974])		0.40 [3.540] (0.35 [3.098])	1.50 [13.277] (0.88 [7.789])	2.18 [19.295] (1.37 [12.126])	4.46 [39.475] (3.56 [31.510])	6.70 [59.302] (6.32 [55.938])
	Rolling	0.12 [1.062] (0.11 [0.974])		0.40 [3.540] (0.35 [3.098])	1.80 [15.932] (0.88 [7.789])	2.18 [19.295] (1.21 [10.710])	4.46 [39.475] (2.99 [26.464])	8.00 [70.808] (5.30 [46.910])
	Yawing	0.21 [1.859] (0.18 [1.593])		0.68 [6.019] (0.60 [5.311])	2.20 [19.472] (1.25 [11.064])	4.18 [36.997] (2.30 [20.357])	7.31 [64.701] (6.00 [53.106])	13.70 [121.259] (11.04 [97.715])

Note: Heat resistant specification is without sensor switch.

Linear guide being used

Cylinder bore	Rail width	Manufacturer	
		Standard, corrosion resistant specifications	Heat resistant specification
φ 8 [0.315], φ 12 [0.472]	5 [0.197]	THK	THK
φ 16 [0.630]	7 [0.276]		
φ 20 [0.787]	9 [0.354]		
φ 25 [0.984]	12 [0.472]		
φ 32 [1.260]	15 [0.591]		
φ 40 [1.575]	20 [0.787]	IKO	

Cylinder bore and stroke

Cylinder bore	Standard stroke
8, 12, 16, 20, 25 [0.315, 0.472, 0.630, 0.787, 0.984]	5 ^{Note} , 10, 15 ^{Note} , 20, 25 ^{Note} , 30, 35 ^{Note} , 40, 45 ^{Note} , 50, 55 ^{Note} , 60
32 [1.260]	10, 15 ^{Note} , 20, 25 ^{Note} , 30, 35 ^{Note} , 40, 45 ^{Note} , 50, 55 ^{Note} , 60
40 [1.575]	10 ^{Note} , 15 ^{Note} , 20, 25 ^{Note} , 30, 35 ^{Note} , 40, 45 ^{Note} , 50, 55 ^{Note} , 60

Note: Collar stopper is used in this stroke.

● Standard specifications

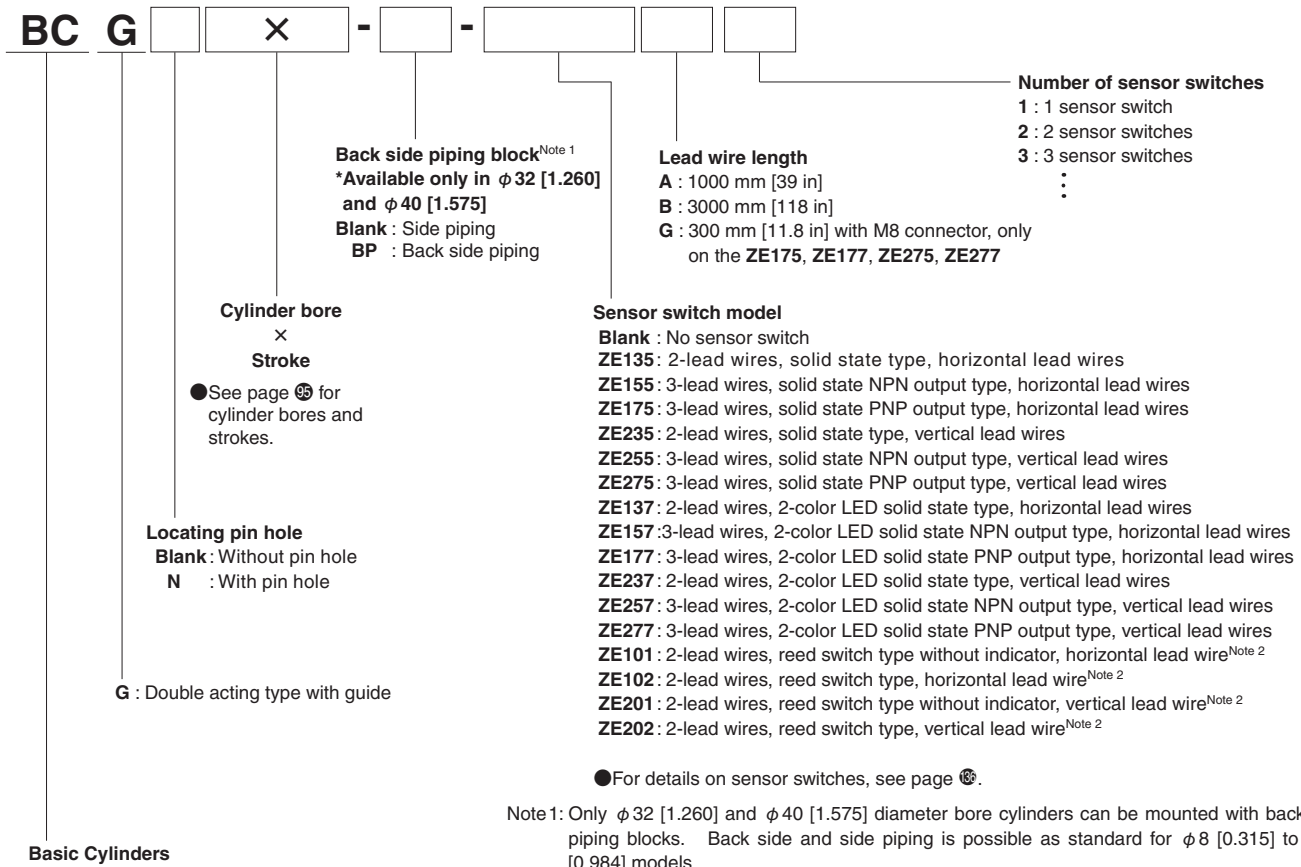

● Corrosion resistant specification (Change of material of piston rod, etc.)

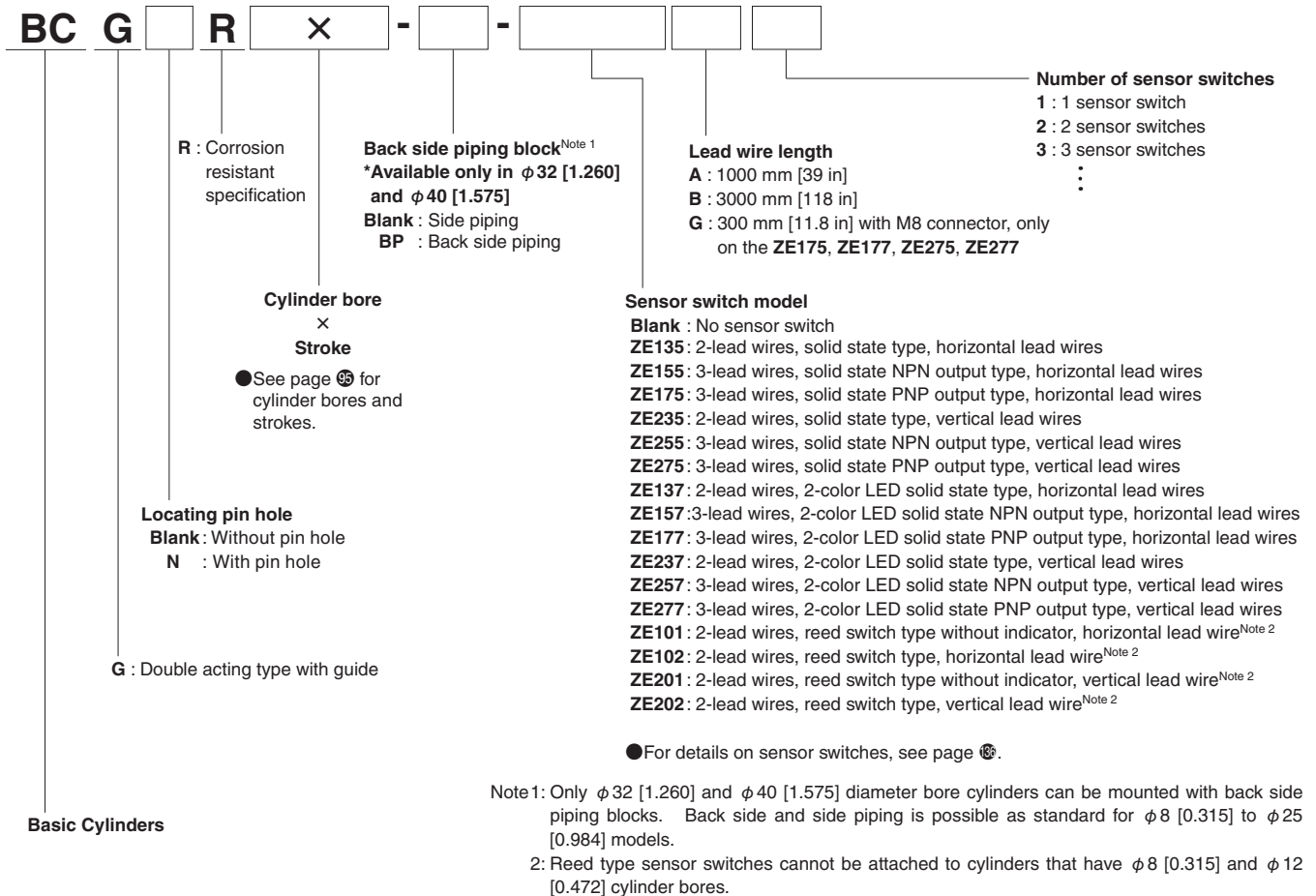

Order Codes

● Heat resistant specification (Sensor switch cannot be attached.)

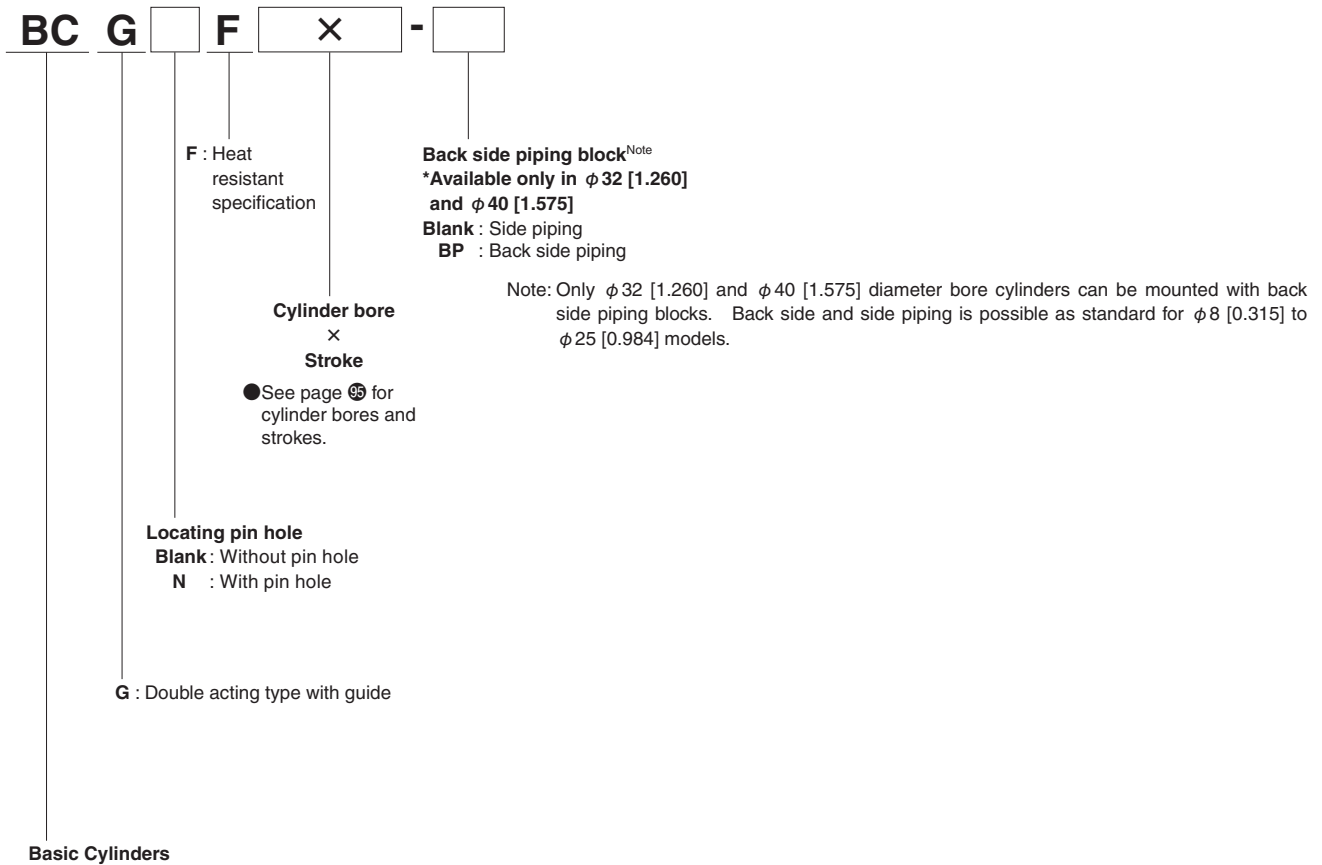

Mass

● Cylinder with guide

unit: g

Model	Stroke mm [in]											
	5 [0.197]	10 [0.394]	15 [0.591]	20 [0.787]	25 [0.984]	30 [1.181]	35 [1.378]	40 [1.575]	45 [1.772]	50 [1.969]	55 [2.165]	60 [2.362]
BCG□8	56	54	68	66	80	78	92	90	104	102	116	114
BCG□12	82	81	96	95	110	109	124	123	138	137	152	151
BCG□16	133	131	155	153	178	176	200	198	222	220	245	243
BCG□20	207 (209)	205 (207)	236 (238)	234 (236)	265 (267)	263 (265)	294 (296)	292 (294)	323 (325)	321 (323)	352 (354)	350 (352)
BCG□25	321 (330)	317 (326)	366 (375)	362 (371)	411 (420)	407 (416)	456 (465)	452 (461)	501 (510)	497 (506)	546 (555)	542 (551)
BCG□32	—	597 (627)	675 (705)	669 (699)	746 (776)	740 (770)	818 (848)	812 (842)	889 (919)	883 (913)	961 (991)	955 (985)
BCG□40	—	1031 (1075)	1025 (1069)	1019 (1063)	1122 (1166)	1116 (1160)	1219 (1263)	1213 (1257)	1316 (1360)	1310 (1354)	1413 (1457)	1407 (1451)

Values in parentheses are mass of heat resistant specification.

In the case of back side piping specifications, mass is 76 g for a $\phi 32$ cylinder bore and 108 g for a $\phi 40$ cylinder bore.

unit: oz

Model	Stroke mm [in]											
	5 [0.197]	10 [0.394]	15 [0.591]	20 [0.787]	25 [0.984]	30 [1.181]	35 [1.378]	40 [1.575]	45 [1.772]	50 [1.969]	55 [2.165]	60 [2.362]
BCG□8	1.975	1.905	2.399	2.328	2.822	2.751	3.245	3.175	3.7	3.6	4.1	4.0
BCG□12	2.892	2.857	3.386	3.351	3.9	3.8	4.4	4.3	4.9	4.8	5.4	5.3
BCG□16	4.7	4.6	5.5	5.4	6.3	6.2	7.1	7.0	7.8	7.8	8.6	8.6
BCG□20	7.3 (7.4)	7.2 (7.3)	8.3 (8.4)	8.3 (8.3)	9.3 (9.4)	9.3 (9.3)	10.4 (10.4)	10.3 (10.4)	11.4 (11.5)	11.3 (11.4)	12.4 (12.5)	12.3 (12.4)
BCG□25	11.3 (11.6)	11.2 (11.5)	12.9 (13.2)	12.8 (13.1)	14.5 (14.8)	14.4 (14.7)	16.1 (16.4)	15.9 (16.3)	17.7 (18.0)	17.5 (17.8)	19.3 (19.6)	19.1 (19.4)
BCG□32	—	21.1 (22.1)	23.8 (24.9)	23.6 (24.7)	26.3 (27.4)	26.1 (27.2)	28.9 (29.9)	28.6 (29.7)	31.4 (32.4)	31.1 (32.2)	33.9 (35.0)	33.7 (34.7)
BCG□40	—	36 (38)	36 (38)	36 (37)	40 (41)	39 (41)	43 (45)	43 (44)	46 (48)	46 (48)	50 (51)	50 (51)

Values in parentheses are mass of heat resistant specification.

In the case of back side piping specifications, mass is 2.681 oz for a $\phi 1.260$ cylinder bore and 3.8 oz for a $\phi 1.575$ cylinder bore.

● Additional mass of sensor switches

ZE□□□A, ZE□□□G: 15 g [0.529 oz] ZE□□□B: 35 g [1.235 oz]

Inner construction

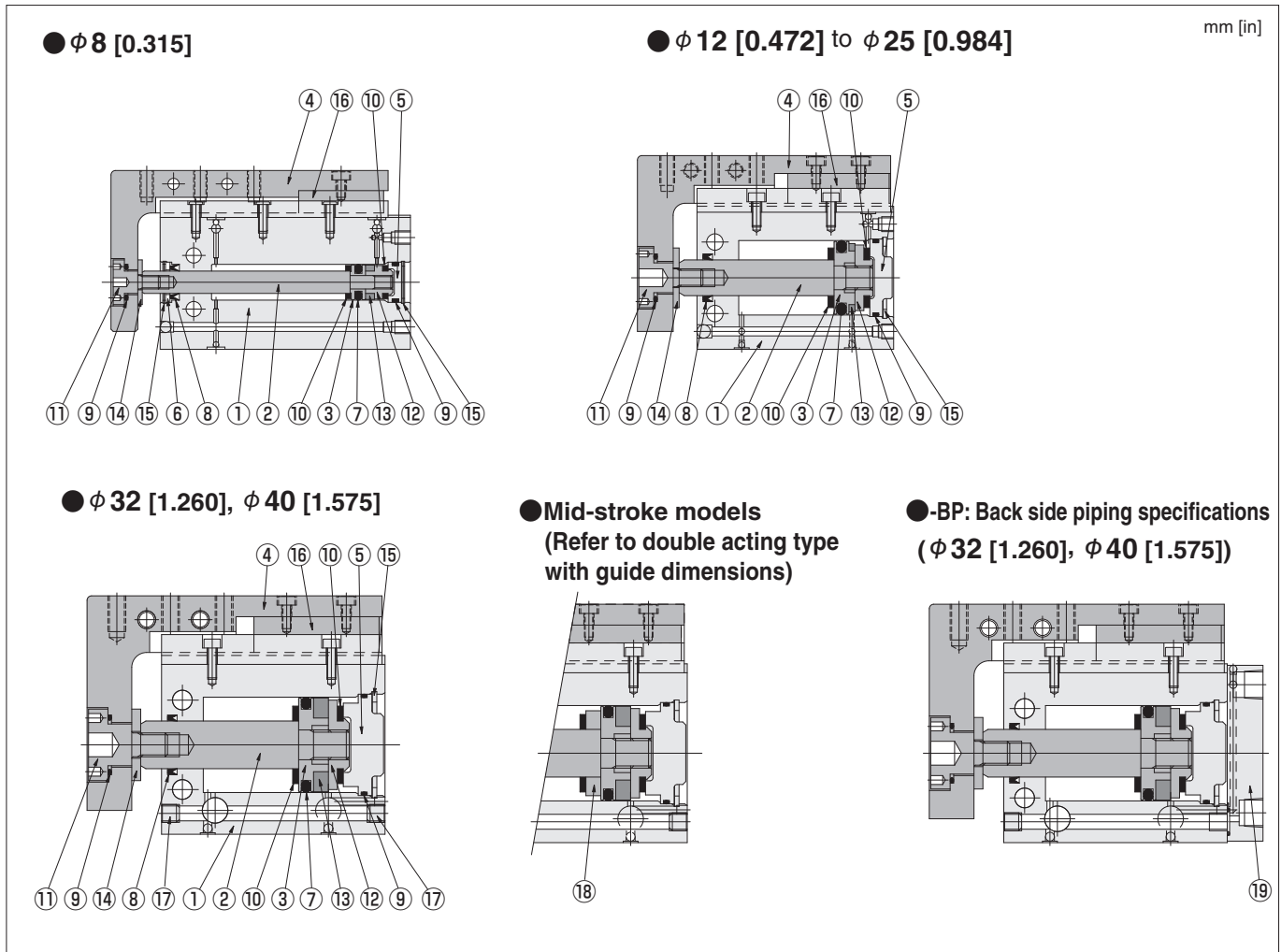

Major parts and materials (standard, corrosion resistant, heat resistant specifications)

No.	Name	φ 8 [0.315]	φ 12 [0.472]	φ 16 [0.630]	φ 20 [0.787]	φ 25 [0.984]	φ 32 [1.260]	φ 40 [1.575]
①	Cylinder body	Aluminum alloy (special anti-abrasion treated)						
②	Piston rod	Stainless steel						Carbon steel (Corrosion and heat resistant specifications are stainless steel.)
③	Piston	Stainless steel	Aluminum alloy (anodized)					
④	Table	Aluminum alloy (anodized)						
⑤	Head cover	Aluminum alloy (anodized)						
⑥	Seal holder	Aluminum alloy (Anodized)	—	—	—	—	—	—
⑦	★ Piston seal	Synthetic rubber (NBR) (heat resistant specification: FKM)						
⑧	★ Rod seal	Synthetic rubber (NBR) (heat resistant specification: FKM)						
⑨	★ O-ring	Synthetic rubber (NBR) (heat resistant specification: FKM)						
⑩	Bumper	Synthetic rubber (NBR) (heat resistant specification: FKM)						
⑪	End bolt	Stainless steel						
⑫	Support	Aluminum alloy (anodized)						
⑬	Magnet	Neodymium magnet (no heat resistant specification)						Plastic magnet (no heat resistant specification)
⑭	Bolt retainer	Stainless steel						
⑮	★ Retaining ring	Stainless steel	Steel (Corrosion and heat resistant specifications are electroless nickel plated.)					
⑯	Linear guide	Stainless steel						
⑰	Plug	—	—	—	—	—	Stainless steel	Stainless steel
⑱	Stopper	Aluminum alloy (anodized)						
⑲	★ Back side piping block	—	—	—	—	—	Aluminum alloy (Anodized)	Aluminum alloy (Anodized)

Items indicated by a ★ are available as additional parts or in packing sets. For order codes, see page 92 and 93.

Double acting type with guide dimensions

unit: mm

- BCG□8
- BCG□R8 (corrosion resistant specification)
- BCG□F8 (heat resistant specification)

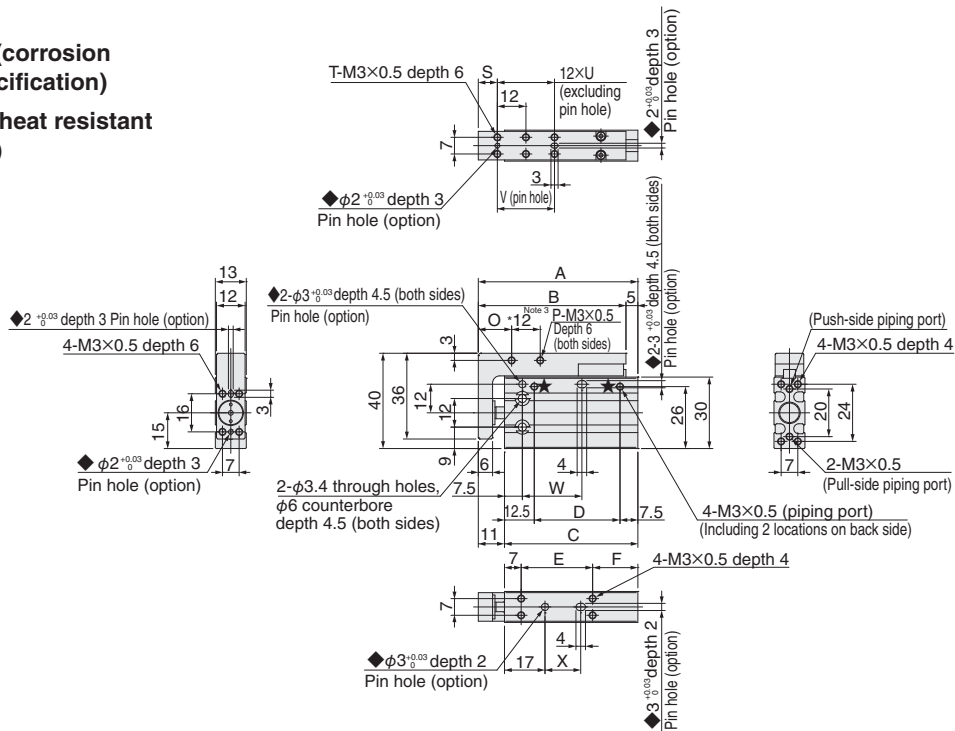

Stroke	A	B	C	D	E	F	O	P	S	T	U	V	W	X
5, 10	47	42	36	16	15	14	10	2	5	4	-	12	15	10
15, 20	57	52	46	26	20	19	14	4	8	4	-	12	15	15
25, 30	67	62	56	36	30	19	14	4	8	6	2	24	25	15
35, 40	77	72	66	46	40	19	14	4	8	8	3	24	25	25
45, 50	87	82	76	56	50	19	14	4	8	10	4	36	35	35
55, 60	97	92	86	66	60	19	14	4	8	12	5	36	35	45

Note 1: This product cannot use reed switch type sensor switches.
 Note 2: 5, 15, 25, 35, 45, and 55 stroke has a collar stopper.
 Note 3: Dimensions indicated by * are for strokes longer than 15.
 Note 4: All piping ports are assembled with plugs, except those indicated by ★.
 Note 5: Apply grease to o-rings when changing plug assemblies.
 Note 6: Pin holes indicated by ◆ are provided only when selected as an option (N).

- BCG□12
- BCG□R12 (corrosion resistant specification)
- BCG□F12 (heat resistant specification)

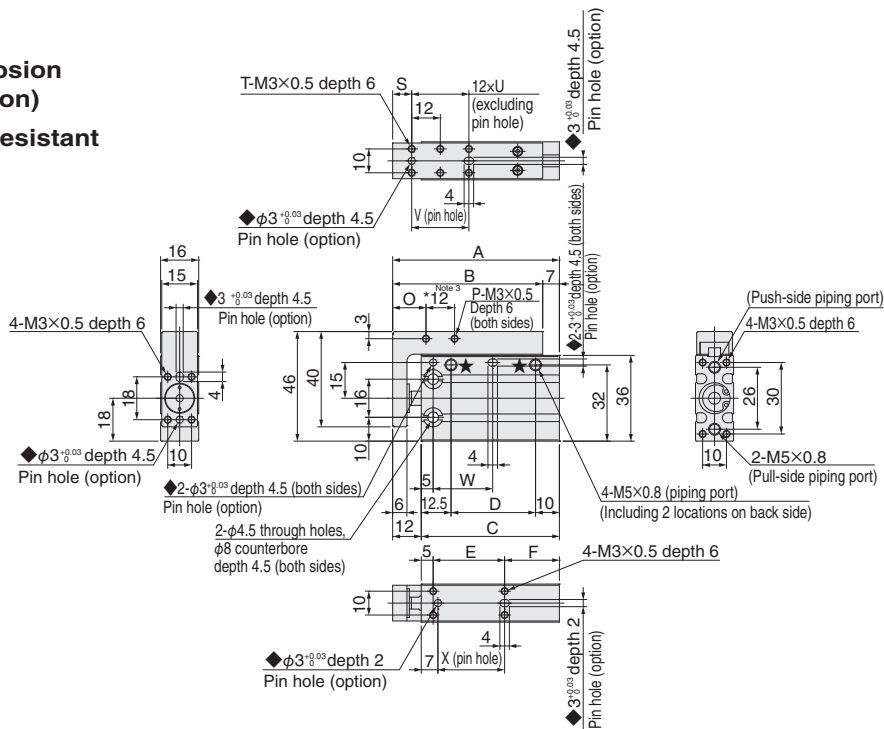

Stroke	A	B	C	D	E	F	O	P	S	T	U	V	W	X
5, 10	50	43	38	15.5	15	18	10	2	5	4	-	12	15	13
15, 20	60	53	48	25.5	20	23	14	4	8	4	-	12	15	18
25, 30	70	63	58	35.5	30	23	14	4	8	6	2	24	25	28
35, 40	80	73	68	45.5	40	23	14	4	8	8	3	24	25	38
45, 50	90	83	78	55.5	50	23	14	4	8	10	4	36	35	48
55, 60	100	93	88	65.5	60	23	14	4	8	12	5	36	35	58

Note 1: This product cannot use reed switch type sensor switches.
 Note 2: 5, 15, 25, 35, 45, and 55 stroke has a collar stopper.
 Note 3: Dimensions indicated by * are for strokes longer than 15.
 Note 4: All piping ports are assembled with plugs, except those indicated by ★.
 Note 5: Apply grease to o-rings when changing plug assemblies.
 Note 6: Pin holes indicated by ◆ are provided only when selected as an option (N).

Double acting type with guide dimensions

unit: in

- BCG 8
- BCG R8 (corrosion resistant specification)
- BCG F8 (heat resistant specification)

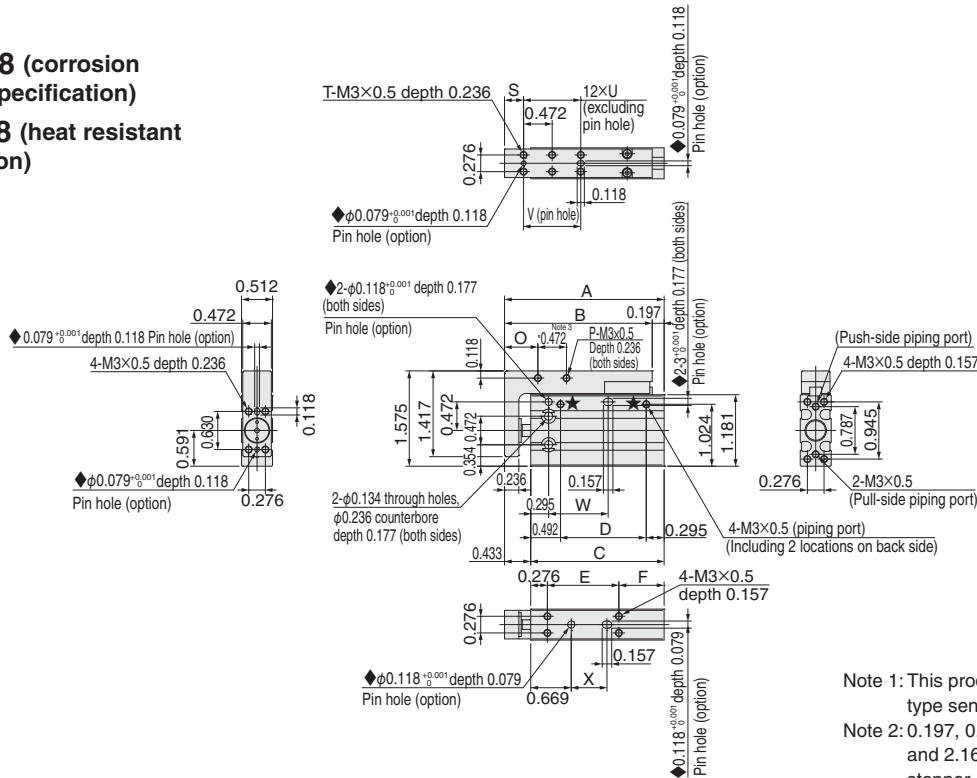

Stroke	A	B	C	D	E	F	O	P	S	T	U	V	W	X
5 mm, 10 mm [0.197, 0.394]	1.850	1.654	1.417	0.630	0.591	0.551	0.394	0.079	0.197	0.157	-	0.472	0.591	0.394
15 mm, 20 mm [0.591, 0.787]	2.244	2.047	1.811	1.024	0.787	0.748	0.551	0.157	0.315	0.157	-	0.472	0.591	0.591
25 mm, 30 mm [0.984, 1.181]	2.638	2.441	2.205	1.417	1.181	0.748	0.551	0.157	0.315	0.236	0.079	0.945	0.984	0.591
35 mm, 40 mm [1.378, 1.575]	3.031	2.835	2.598	1.811	1.575	0.748	0.551	0.157	0.315	0.315	0.118	0.945	0.984	0.984
45 mm, 50 mm [1.772, 1.969]	3.425	3.228	2.992	2.205	1.969	0.748	0.551	0.157	0.315	0.394	0.157	1.417	1.378	1.378
55 mm, 60 mm [2.165, 2.362]	3.819	3.622	3.386	2.598	2.362	0.748	0.551	0.157	0.315	0.472	0.197	1.417	1.378	1.772

- Note 1: This product cannot use reed switch type sensor switches.
- Note 2: 0.197, 0.591, 0.984, 1.378, 1.772, and 2.165 stroke has a collar stopper.
- Note 3: Dimensions indicated by * are for strokes longer than 0.591.
- Note 4: All piping ports are assembled with plugs, except those indicated by ★.
- Note 5: Apply grease to o-rings when changing plug assemblies.
- Note 6: Pin holes indicated by ◆ are provided only when selected as an option (N).

- BCG 12
- BCG R12 (corrosion resistant specification)
- BCG F12 (heat resistant specification)

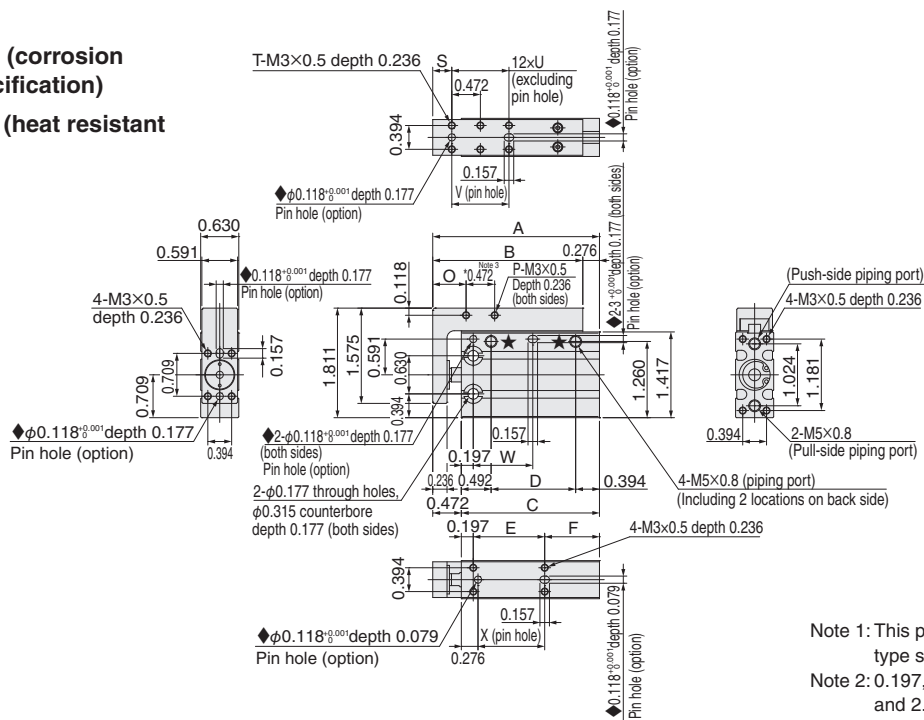

Stroke	A	B	C	D	E	F	O	P	S	T	U	V	W	X
5 mm, 10 mm [0.197, 0.394]	1.969	1.693	1.496	0.610	0.591	0.709	0.394	0.079	0.197	0.157	-	0.472	0.591	0.512
15 mm, 20 mm [0.591, 0.787]	2.362	2.087	1.890	1.004	0.787	0.906	0.551	0.157	0.315	0.157	-	0.472	0.591	0.709
25 mm, 30 mm [0.984, 1.181]	2.756	2.480	2.283	1.398	1.181	0.906	0.551	0.157	0.315	0.236	0.079	0.945	0.984	1.102
35 mm, 40 mm [1.378, 1.575]	3.150	2.874	2.677	1.791	1.575	0.906	0.551	0.157	0.315	0.315	0.118	0.945	0.984	1.496
45 mm, 50 mm [1.772, 1.969]	3.543	3.268	3.071	2.185	1.969	0.906	0.551	0.157	0.315	0.394	0.157	1.417	1.378	1.890
55 mm, 60 mm [2.165, 2.362]	3.937	3.661	3.465	2.579	2.362	0.906	0.551	0.157	0.315	0.472	0.197	1.417	1.378	2.283

- Note 1: This product cannot use reed switch type sensor switches.
- Note 2: 0.197, 0.591, 0.984, 1.378, 1.772, and 2.165 stroke has a collar stopper.
- Note 3: Dimensions indicated by * are for strokes longer than 0.591.
- Note 4: All piping ports are assembled with plugs, except those indicated by ★.
- Note 5: Apply grease to o-rings when changing plug assemblies.
- Note 6: Pin holes indicated by ◆ are provided only when selected as an option (N).

Double acting type with guide dimensions

unit: mm

- BCG□16
- BCG□R16 (corrosion resistant specification)
- BCG□F16 (heat resistant specification)

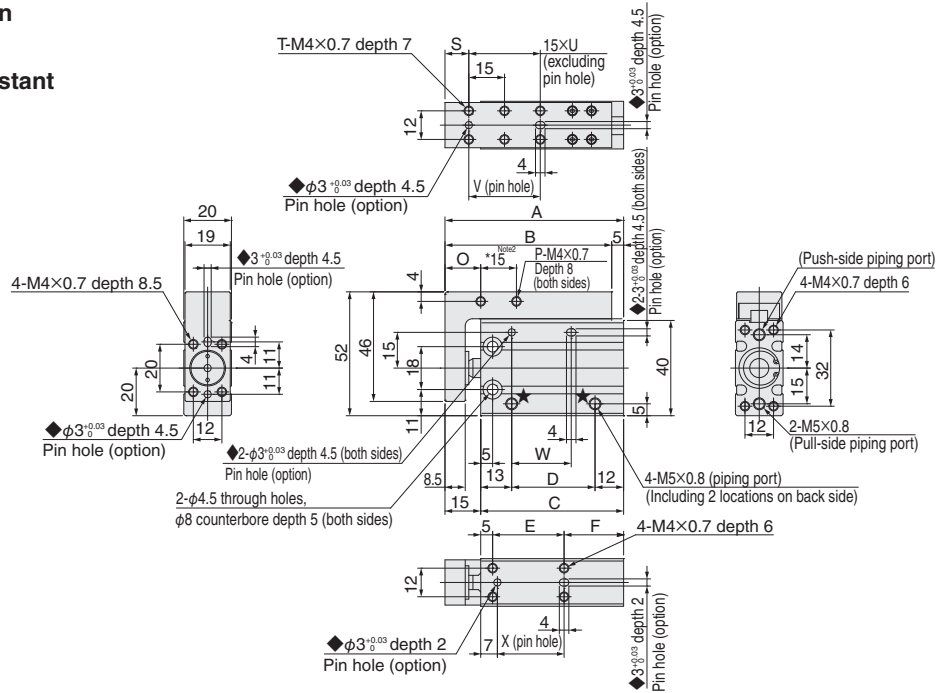

Stroke	A	B	C	D	E	F	O	P	S	T	U	V	W	X
5, 10	55	50	40	15	15	20	12	2	5	4	-	15	15	13
15, 20	65	60	50	25	20	25	15	4	10	4	-	15	15	18
25, 30	75	70	60	35	30	25	15	4	10	6	2	30	25	28
35, 40	85	80	70	45	40	25	15	4	10	6	2	30	25	38
45, 50	95	90	80	55	50	25	15	4	10	8	3	45	35	48
55, 60	105	100	90	65	60	25	15	4	10	10	4	45	35	58

Note 1: 5, 15, 25, 35, 45, and 55 stroke support collar stopper.
 Note 2: Dimensions indicated by * are for strokes longer than 15.
 Note 3: All piping ports are assembled with plugs, except those indicated by ★.
 Note 4: Apply grease to o-rings when changing plug assemblies.
 Note 5: Pin holes indicated by ◆ are provided only when selected as an option (N).

- BCG□20
- BCG□R20 (corrosion resistant specification)
- BCG□F20 (heat resistant specification)

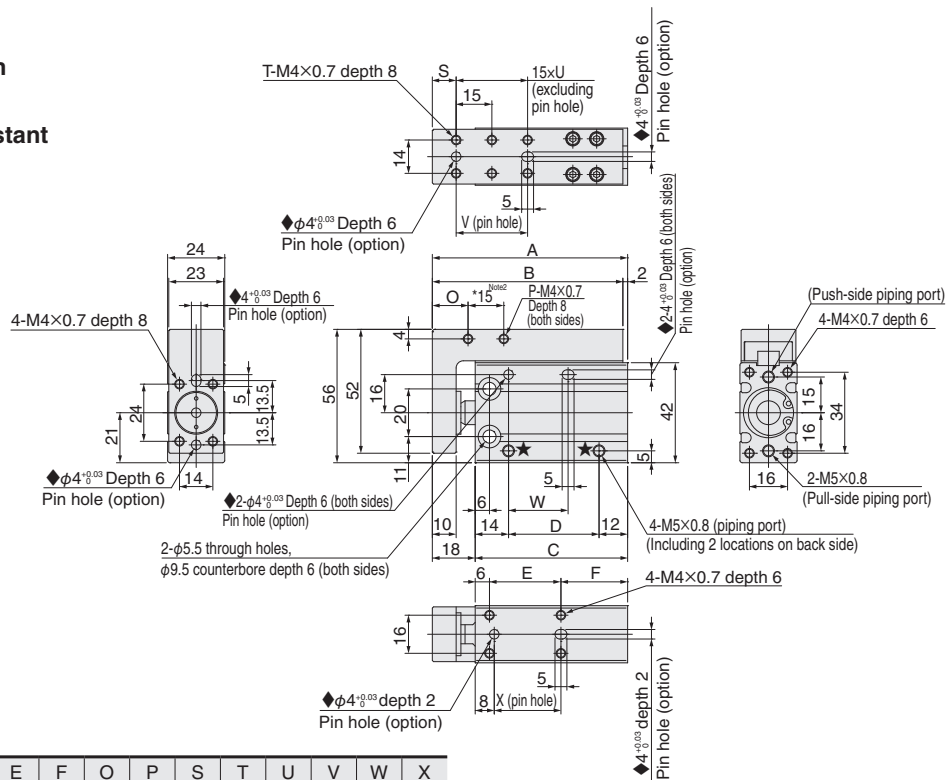

Stroke	A	B	C	D	E	F	O	P	S	T	U	V	W	X
5, 10	62	60	44	18	15	23	12	2	5	4	-	15	15	13
15, 20	72	70	54	28	20	28	15	4	10	4	-	15	15	18
25, 30	82	80	64	38	30	28	15	4	10	6	2	30	25	28
35, 40	92	90	74	48	40	28	15	4	10	6	2	30	25	38
45, 50	102	100	84	58	50	28	15	4	10	8	3	45	35	48
55, 60	112	110	94	68	60	28	15	4	10	10	4	45	35	58

Note 1: 5, 15, 25, 35, 45, and 55 stroke support collar stopper.
 Note 2: Dimensions indicated by * are for strokes longer than 15.
 Note 3: All piping ports are assembled with plugs, except those indicated by ★.
 Note 4: Apply grease to o-rings when changing plug assemblies.
 Note 5: Pin holes indicated by ◆ are provided only when selected as an option (N).

- BCG□16
- BCG□R16 (corrosion resistant specification)
- BCG□F16 (heat resistant specification)

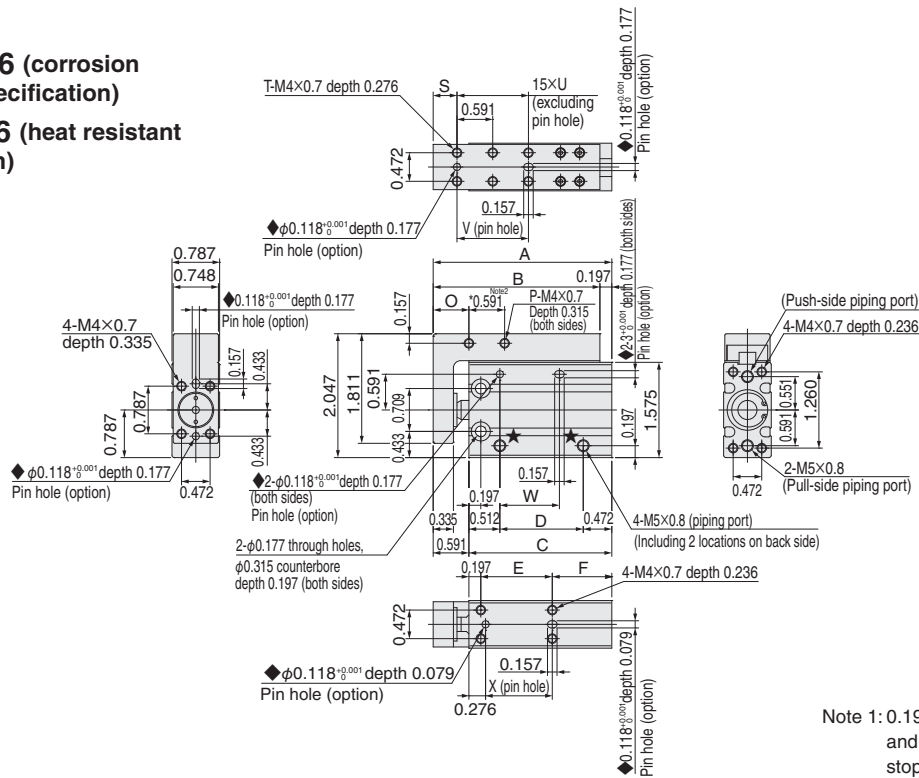

Stroke	A	B	C	D	E	F	O	P	S	T	U	V	W	X
5 mm, 10 mm [0.197, 0.394]	2.165	1.969	1.575	0.591	0.591	0.787	0.472	0.079	0.197	0.157	-	0.591	0.591	0.512
15 mm, 20 mm [0.591, 0.787]	2.559	2.362	1.969	0.984	0.787	0.984	0.591	0.157	0.394	0.157	-	0.591	0.591	0.709
25 mm, 30 mm [0.984, 1.181]	2.953	2.756	2.362	1.378	1.181	0.984	0.591	0.157	0.394	0.236	0.079	1.181	0.984	1.102
35 mm, 40 mm [1.378, 1.575]	3.346	3.150	2.756	1.772	1.575	0.984	0.591	0.157	0.394	0.236	0.079	1.181	0.984	1.496
45 mm, 50 mm [1.772, 1.969]	3.740	3.543	3.150	2.165	1.969	0.984	0.591	0.157	0.394	0.315	0.118	1.772	1.378	1.890
55 mm, 60 mm [2.165, 2.362]	4.134	3.937	3.543	2.559	2.362	0.984	0.591	0.157	0.394	0.394	0.157	1.772	1.378	2.283

- Note 1: 0.197, 0.591, 0.984, 1.378, 1.772, and 2.165 stroke support collar stopper.
- Note 2: Dimensions indicated by * are for strokes longer than 0.591.
- Note 3: All piping ports are assembled with plugs, except those indicated by ★.
- Note 4: Apply grease to o-rings when changing plug assemblies.
- Note 5: Pin holes indicated by ◆ are provided only when selected as an option (N).

- BCG□20
- BCG□R20 (corrosion resistant specification)
- BCG□F20 (heat resistant specification)

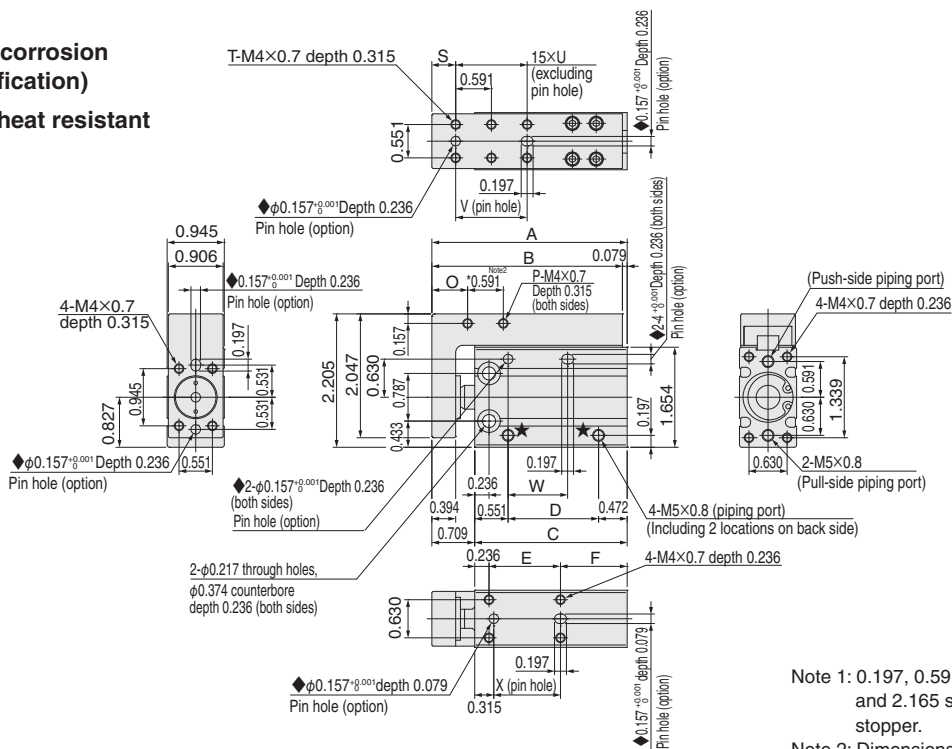

Stroke	A	B	C	D	E	F	O	P	S	T	U	V	W	X
5 mm, 10 mm [0.197, 0.394]	2.441	2.362	1.732	0.709	0.591	0.906	0.472	0.079	0.197	0.157	-	0.591	0.591	0.512
15 mm, 20 mm [0.591, 0.787]	2.835	2.756	2.126	1.102	0.787	1.102	0.591	0.157	0.394	0.157	-	0.591	0.591	0.709
25 mm, 30 mm [0.984, 1.181]	3.228	3.150	2.520	1.496	1.181	1.102	0.591	0.157	0.394	0.236	0.079	1.181	0.984	1.102
35 mm, 40 mm [1.378, 1.575]	3.622	3.543	2.913	1.890	1.575	1.102	0.591	0.157	0.394	0.236	0.079	1.181	0.984	1.496
45 mm, 50 mm [1.772, 1.969]	4.016	3.937	3.307	2.283	1.969	1.102	0.591	0.157	0.394	0.315	0.118	1.772	1.378	1.890
55 mm, 60 mm [2.165, 2.362]	4.409	4.331	3.701	2.677	2.362	1.102	0.591	0.157	0.394	0.394	0.157	1.772	1.378	2.283

- Note 1: 0.197, 0.591, 0.984, 1.378, 1.772, and 2.165 stroke support collar stopper.
- Note 2: Dimensions indicated by * are for strokes longer than 0.591.
- Note 3: All piping ports are assembled with plugs, except those indicated by ★.
- Note 4: Apply grease to o-rings when changing plug assemblies.
- Note 5: Pin holes indicated by ◆ are provided only when selected as an option (N).

Double acting type with guide dimensions

unit: mm

- BCG□25
- BCG□R25 (corrosion resistant specification)
- BCG□F25 (heat resistant specification)

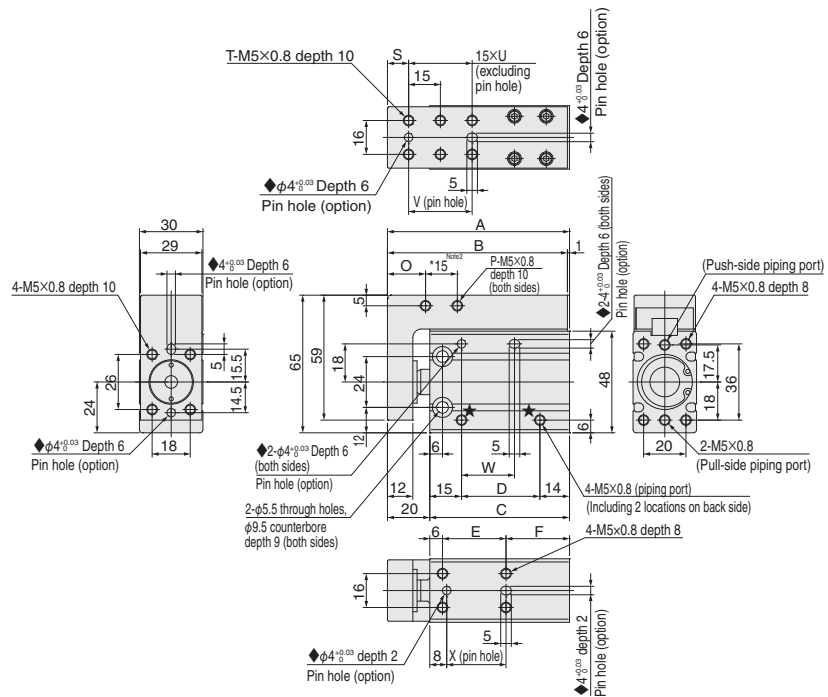

Stroke	A	B	C	D	E	F	O	P	S	T	U	V	W	X
5, 10	66	65	46	17	15	25	12	2	5	4	-	15	15	15
15, 20	76	75	56	27	20	30	18	4	10	4	-	15	15	18
25, 30	86	85	66	37	30	30	18	4	10	6	2	30	25	28
35, 40	96	95	76	47	40	30	18	4	10	6	2	30	25	38
45, 50	106	105	86	57	50	30	18	4	10	8	3	45	35	48
55, 60	116	115	96	67	60	30	18	4	10	10	4	45	35	58

Note 1: 5, 15, 25, 35, 45, and 55 stroke support collar stopper.
 Note 2: Dimensions indicated by * are for strokes longer than 15.
 Note 3: All piping ports are assembled with plugs, except those indicated by ★.
 Note 4: Apply grease to o-rings when changing plug assemblies.
 Note 5: Pin holes indicated by ◆ are provided only when selected as an option (N).

- BCG□32
- BCG□R32 (corrosion resistant specification)
- BCG□F32 (heat resistant specification)

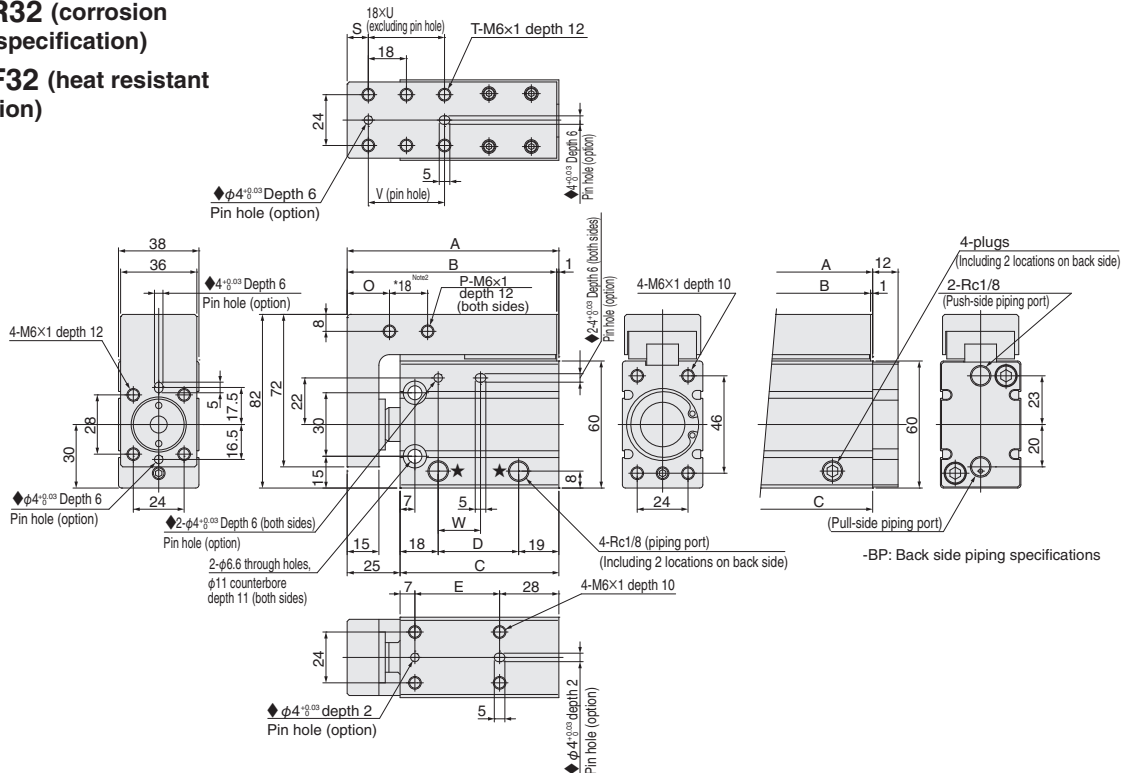

Note 1: 15, 25, 35, 45, and 55 stroke support collar stopper.
 Note 2: Dimensions indicated by * are for strokes longer than 25.
 Note 3: All piping ports are assembled with plugs, except those indicated by ★. However, in the case of the corrosion resistant specification, plugs are included for specifications other than back side piping specifications. Assemble using sealant, etc.
 Note 4: Pin holes indicated by ◆ are provided only when selected as an option (N).

Stroke	A	B	C	D	E	O	P	S	T	U	V	W
10	80	79	55	18	20	16	2	6	4	-	18	20
15, 20	90	89	65	28	30	20	2	10	4	-	18	20
25, 30	100	99	75	38	40	20	4	10	6	2	36	30
35, 40	110	109	85	48	50	20	4	10	6	2	36	30
45, 50	120	119	95	58	60	20	4	10	8	3	54	40
55, 60	130	129	105	68	70	20	4	10	8	3	54	40

Double acting type with guide dimensions

unit: in

- BCG □ 25
- BCG □ R25 (corrosion resistant specification)
- BCG □ F25 (heat resistant specification)

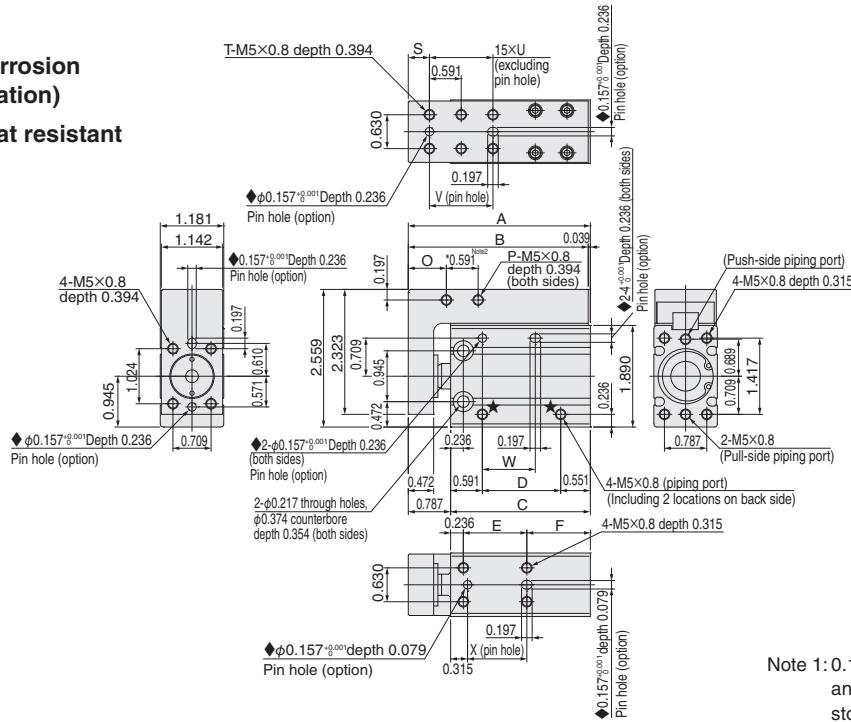

Stroke	A	B	C	D	E	F	O	P	S	T	U	V	W	X
5 mm, 10 mm [0.197, 0.394]	2.598	2.559	1.811	0.669	0.591	0.984	0.472	0.079	0.197	0.157	-	0.591	0.591	0.591
15 mm, 20 mm [0.591, 0.787]	2.992	2.953	2.205	1.063	0.787	1.181	0.709	0.157	0.394	0.157	-	0.591	0.591	0.709
25 mm, 30 mm [0.984, 1.181]	3.386	3.346	2.598	1.457	1.181	1.181	0.709	0.157	0.394	0.236	0.079	1.181	0.984	1.102
35 mm, 40 mm [1.378, 1.575]	3.780	3.740	2.992	1.850	1.575	1.181	0.709	0.157	0.394	0.236	0.079	1.181	0.984	1.496
45 mm, 50 mm [1.772, 1.969]	4.173	4.134	3.386	2.244	1.969	1.181	0.709	0.157	0.394	0.315	0.118	1.772	1.378	1.890
55 mm, 60 mm [2.165, 2.362]	4.567	4.528	3.780	2.638	2.362	1.181	0.709	0.157	0.394	0.394	0.157	1.772	1.378	2.283

Note 1: 0.197, 0.591, 0.984, 1.378, 1.772, and 2.165 stroke support collar stopper.

Note 2: Dimensions indicated by * are for strokes longer than 0.591.

Note 3: All piping ports are assembled with plugs, except those indicated by ★.

Note 4: Apply grease to o-rings when changing plug assemblies.

Note 5: Pin holes indicated by ◆ are provided only when selected as an option (N).

- BCG □ 32
- BCG □ R32 (corrosion resistant specification)
- BCG □ F32 (heat resistant specification)

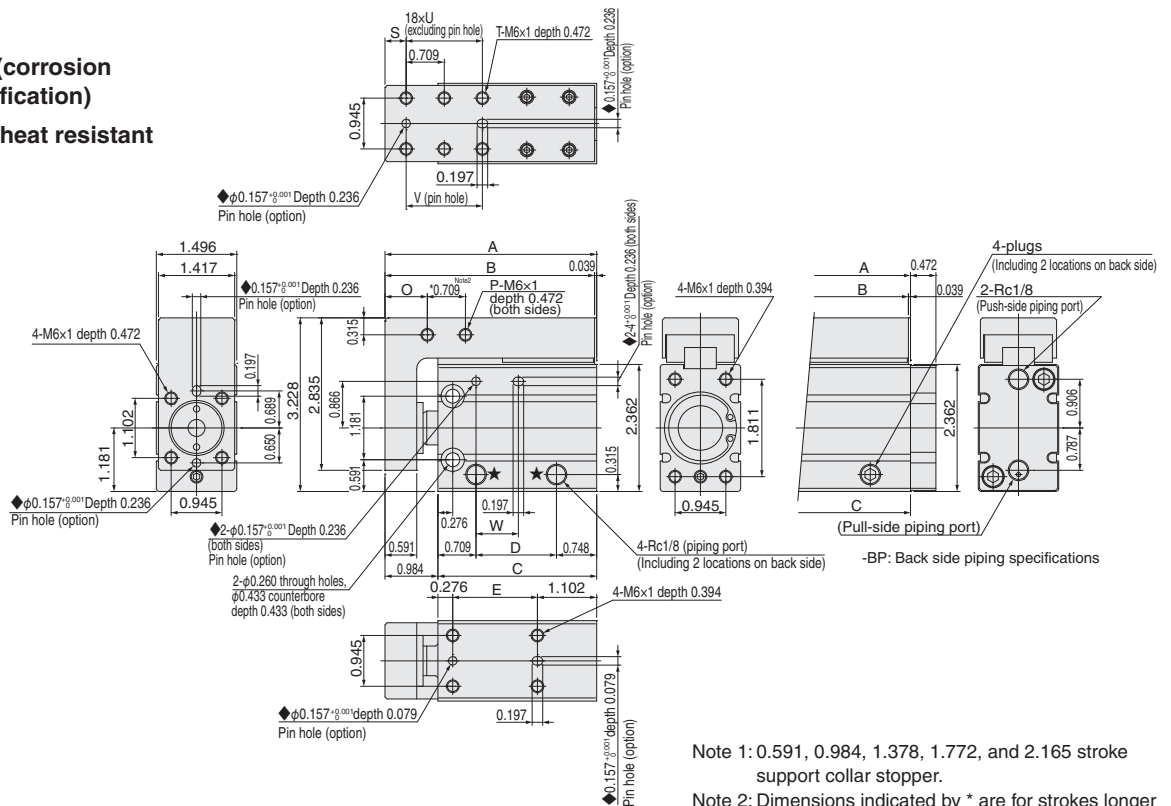

Stroke	A	B	C	D	E	O	P	S	T	U	V	W
10 mm [0.394]	3.150	3.110	2.165	0.709	0.787	0.630	0.079	0.236	0.157	-	0.709	0.787
15 mm, 20 mm [0.591, 0.787]	3.543	3.504	2.559	1.102	1.181	0.787	0.079	0.394	0.157	-	0.709	0.787
25 mm, 30 mm [0.984, 1.181]	3.937	3.898	2.953	1.496	1.575	0.787	0.157	0.394	0.236	0.079	1.417	1.181
35 mm, 40 mm [1.378, 1.575]	4.331	4.291	3.346	1.890	1.969	0.787	0.157	0.394	0.236	0.079	1.417	1.181
45 mm, 50 mm [1.772, 1.969]	4.724	4.685	3.740	2.283	2.362	0.787	0.157	0.394	0.315	0.118	2.126	1.575
55 mm, 60 mm [2.165, 2.362]	5.118	5.079	4.134	2.677	2.756	0.787	0.157	0.394	0.315	0.118	2.126	1.575

Note 1: 0.591, 0.984, 1.378, 1.772, and 2.165 stroke support collar stopper.

Note 2: Dimensions indicated by * are for strokes longer than 0.984.

Note 3: All piping ports are assembled with plugs, except those indicated by ★. However, in the case of the corrosion resistant specification, plugs are included for specifications other than back side piping specifications. Assemble using sealant, etc.

Note 4: Pin holes indicated by ◆ are provided only when selected as an option (N).

Double acting type with guide dimensions

unit: mm

- BCG□40
- BCG□R40 (corrosion resistant specification)
- BCG□F40 (heat resistant specification)

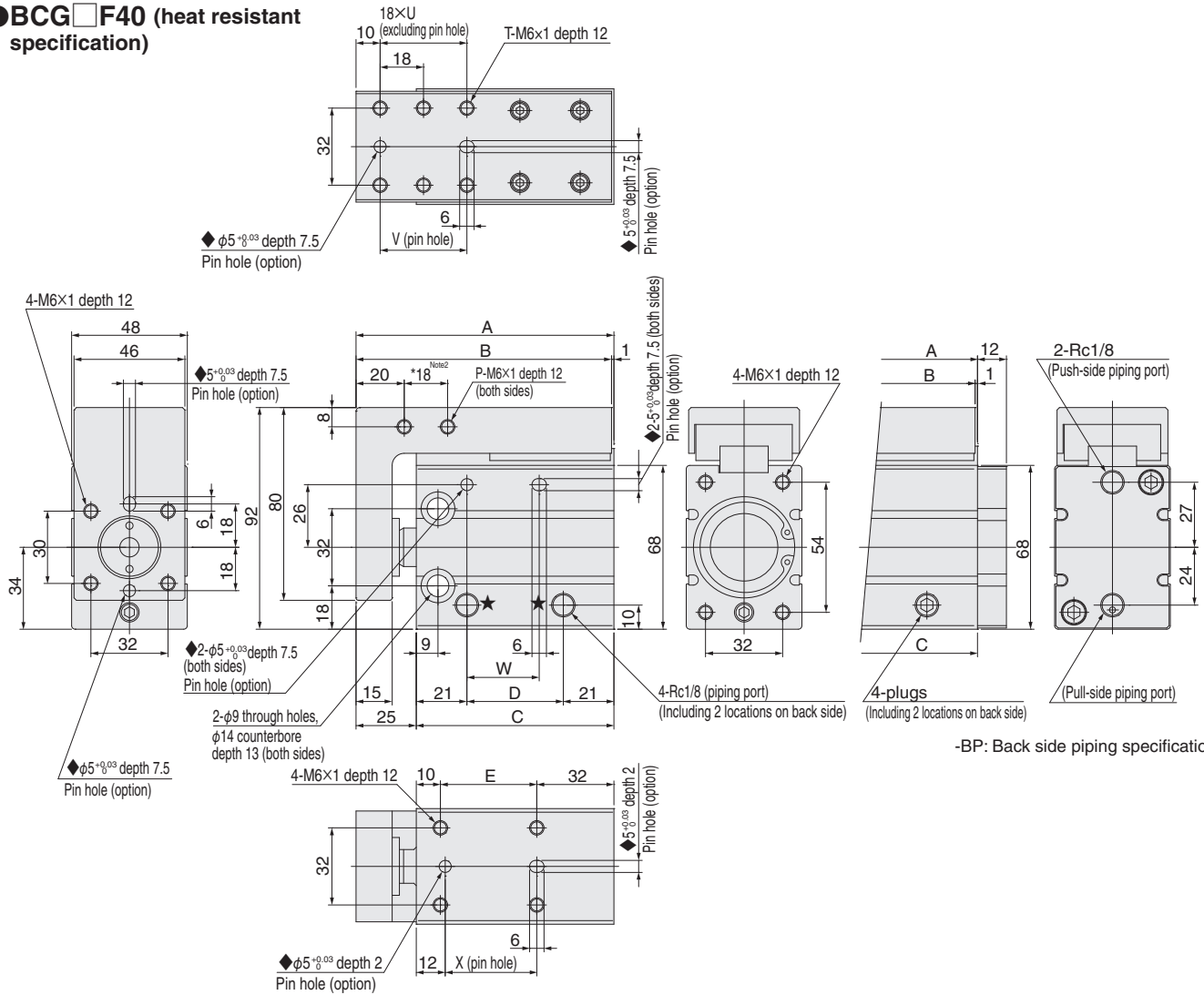

-BP: Back side piping specifications

Stroke	A	B	C	D	E	P	T	U	V	W	X
10, 15, 20	97	96	72	30	30	2	4	-	18	25	28
25, 30	107	106	82	40	40	4	6	2	36	30	38
35, 40	117	116	92	50	50	4	6	2	36	30	48
45, 50	127	126	102	60	60	4	8	3	54	40	58
55, 60	137	136	112	70	70	4	8	3	54	40	68

Note 1: 10, 15, 25, 35, 45, and 55 stroke support collar stopper.

Note 2: Dimensions indicated by * are for strokes longer than 25.

Note 3: All piping ports are assembled with plugs, except those indicated by ★.

However, in the case of the corrosion resistant specification, plugs are included for specifications other than back side piping specifications.

Assemble using sealant, etc.

Note 4: Pin holes indicated by ◆ are provided only when selected as an option (N).

Double acting type with guide dimensions

unit: in

- BCG □ 40
- BCG □ R40 (corrosion resistant specification)
- BCG □ F40 (heat resistant specification)

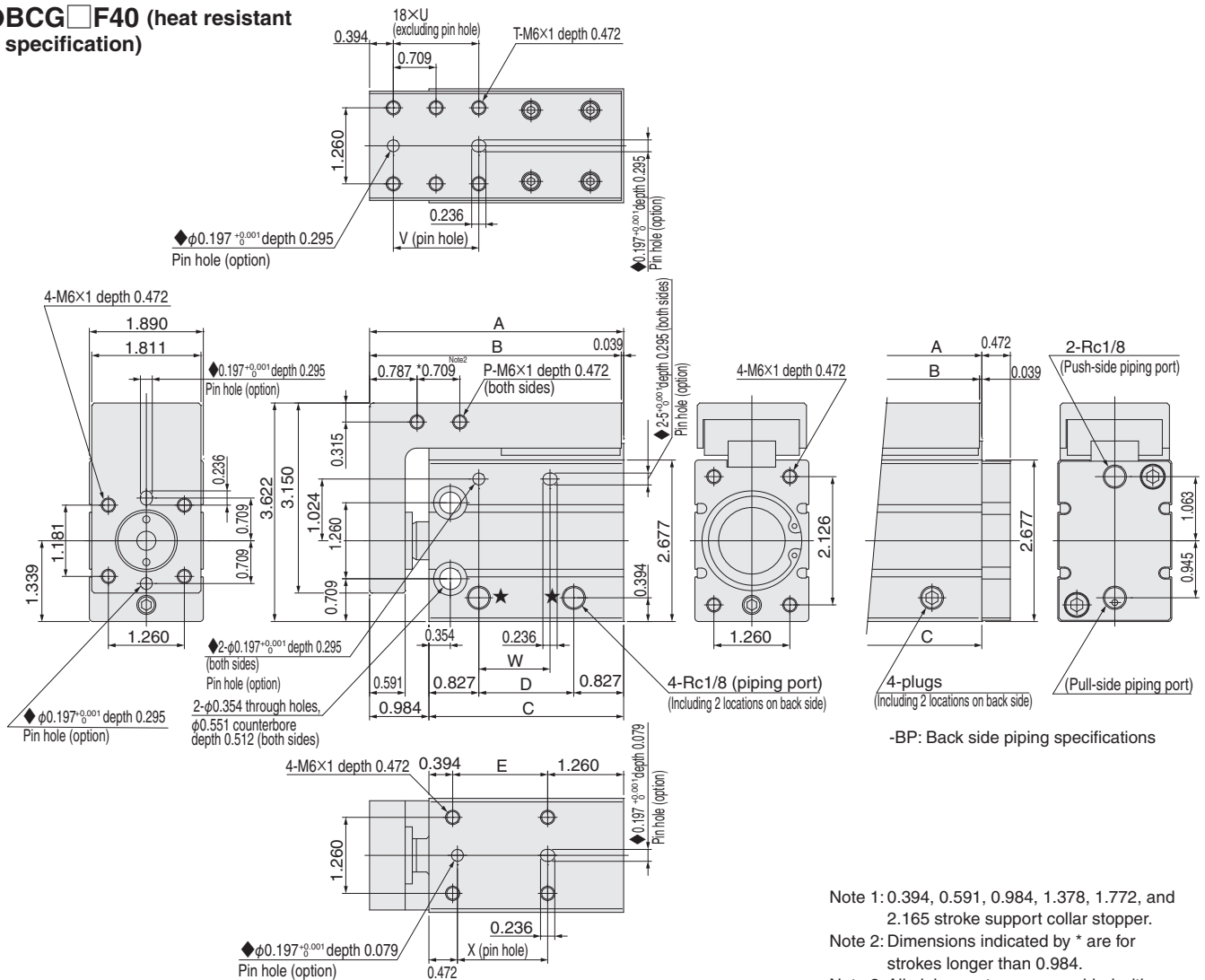

-BP: Back side piping specifications

- Note 1: 0.394, 0.591, 0.984, 1.378, 1.772, and 2.165 stroke support collar stopper.
- Note 2: Dimensions indicated by * are for strokes longer than 0.984.
- Note 3: All piping ports are assembled with plugs, except those indicated by ★. However, in the case of the corrosion resistant specification, plugs are included for specifications other than back side piping specifications. Assemble using sealant, etc.
- Note 4: Pin holes indicated by ◆ are provided only when selected as an option (N).

Stroke	A	B	C	D	E	P	T	U	V	W	X
10 mm, 15 mm, 20 mm [0.394, 0.591, 0.787]	3.819	3.780	2.835	1.181	1.181	0.079	0.157	-	0.709	0.984	1.102
25 mm, 30 mm [0.984, 1.181]	4.213	4.173	3.228	1.575	1.575	0.157	0.236	0.079	1.417	1.181	1.496
35 mm, 40 mm [1.378, 1.575]	4.606	4.567	3.622	1.969	1.969	0.157	0.236	0.079	1.417	1.181	1.890
45 mm, 50 mm [1.772, 1.969]	5.000	4.961	4.016	2.362	2.362	0.157	0.315	0.118	2.126	1.575	2.283
55 mm, 60 mm [2.165, 2.362]	5.394	5.354	4.409	2.756	2.756	0.157	0.315	0.118	2.126	1.575	2.677

Basic Cylinders

Clean system compatible cylinders
Double acting type (single rod)



Symbol

● Double acting type

Without dust collection port

With dust collection port

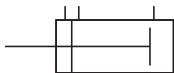
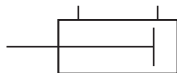

Specifications

● Double acting type (clean room specification)

Item	Cylinder bore	6 ^{Note1}	8 ^{Note1}	10 [0.394]	12 [0.472]	16 [0.630]	20 [0.787]	25 [0.984]	32 [1.260]	40 [1.575]	50 [1.969]	63 [2.480]
		[0.236]	[0.315]									
Operating type		Double acting type										
Medium		Air										
Operating pressure range	MPa [psi]	0.12 to 0.7 [17 to 102]			0.06 to 0.7 [9 to 102]			0.05 to 0.7 [7 to 102]				
Proof pressure	MPa [psi]	1.05 [152]										
Operating temperature range	°C [°F]	0 to 60 [32 to 140]										
Operating speed range	mm/s [in/sec]	10 to 300 [0.394 to 11.8]										
Cushion		Rubber bumper										
Lubrication		No										
Port size		M3×0.5			M5×0.8				Rc1/8		Rc1/4	
Clean room rating ^{Note2}	With dust collection port	—			Class 5 equivalent (FED-STD Class 100 equivalent) ^{Note3}							
	Without dust collection port	Class 6 equivalent (FED-STD Class 1000 equivalent) ^{Note3}										

Note 1: Dust collection port not available for cylinder bores ϕ 6 [0.236] and ϕ 8 [0.315].

Note 2: Koganei standard. For "with cylinder port," in the case of vacuum suction from cylinder port.

Note 3: FED-STD was abolished as of November 2001, and it is designed here for reference purposed.

Cylinder bore and stroke

● Double acting type

Cylinder bore	Standard stroke	Maximum available stroke
6 [0.236] ^{Note1} , 8 [0.315] ^{Note1} , 10 [0.394]	5, 10, 15, 20, 25, 30	50 [1.969]
12, 16 [0.472, 0.630]	5, 10, 15, 20, 25, 30, 35, 40, 45, 50	100 [3.937]
20, 25 [0.787, 0.984]	5 ^{Note2} , 10, 15, 20, 25, 30, 35, 40, 45, 50, 55, 60, 70, 75, 80, 90, 100	125 [4.921]
32, 40 [1.260, 1.575]	10, 15, 20, 25, 30, 35, 40, 45, 50, 55, 60, 70, 75, 80, 90, 100	200 [7.874]
50 [1.969], 63 [2.480]	10, 15, 20, 25, 30, 35, 40, 45, 50, 55, 60, 70, 75, 80, 90, 100	200 [7.874]

Note 1: Dust collection port not available for cylinder bores ϕ 6 [0.236] and ϕ 8 [0.315].

Note 2: Collar stopper is used in this stroke.

■ Double acting type (single rod)

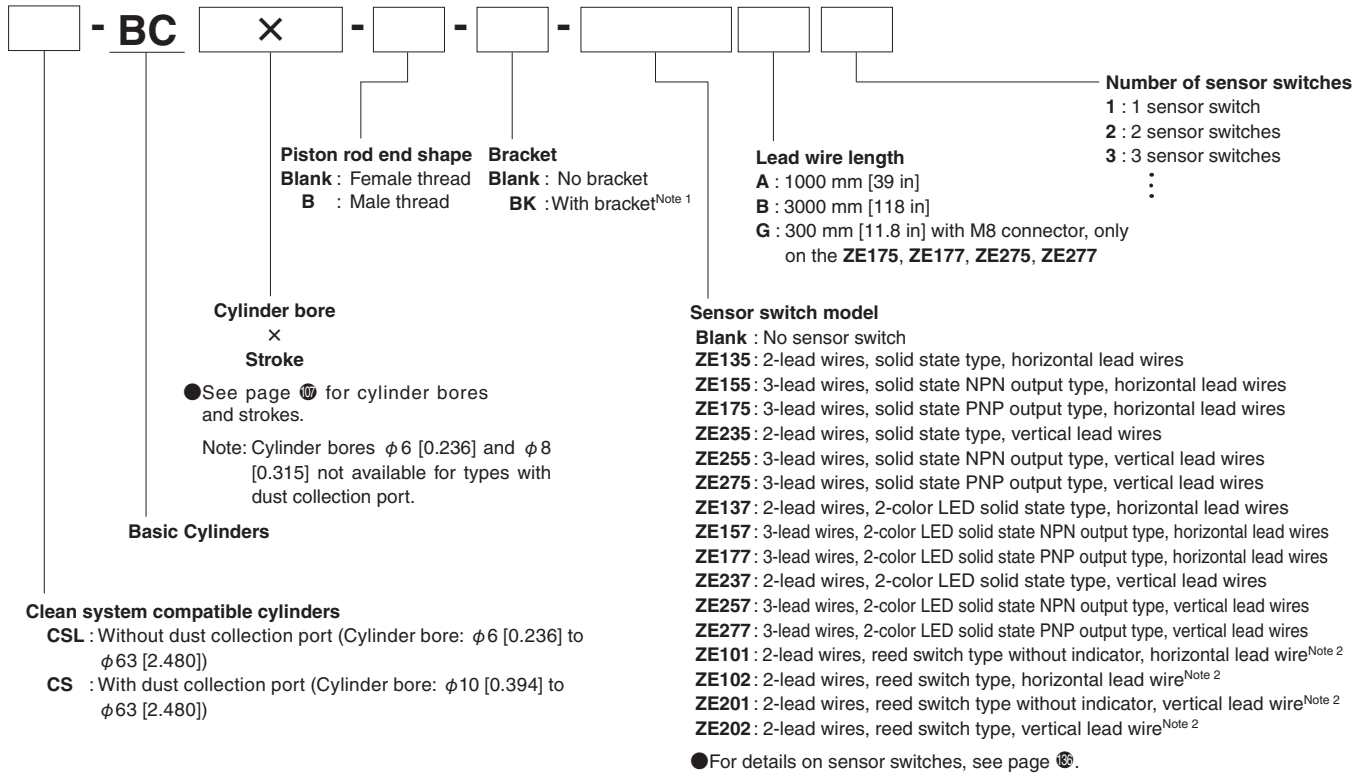

Note 1: Brackets cannot be attached to cylinders that have $\phi 6$ [0.236] and $\phi 8$ [0.315] cylinder bores.
2: Reed type sensor switches cannot be attached to cylinders that have $\phi 6$ [0.236], $\phi 8$ [0.315], $\phi 10$ [0.394], or $\phi 12$ [0.472] cylinder bores.
3: When using reed switch type sensor switches, operates at cylinder speed of 30 mm/s [1.181 in/sec] or higher.

Mass

● **Double acting type (clean room specification, without dust collection port)**

unit: g

Model	Stroke mm [in]																
	5 [0.197]	10 [0.394]	15 [0.591]	20 [0.787]	25 [0.984]	30 [1.181]	35 [1.378]	40 [1.575]	45 [1.772]	50 [1.969]	55 [2.165]	60 [2.362]	70 [2.756]	75 [2.953]	80 [3.150]	90 [3.543]	100 [3.9]
CSL-BC6	13 (15)	16 (18)	20 (22)	23 (25)	27 (29)	30 (32)	-	-	-	-	-	-	-	-	-	-	-
CSL-BC8	19 (21)	21 (23)	24 (26)	27 (29)	31 (32)	32 (34)	-	-	-	-	-	-	-	-	-	-	-
CSL-BC10	21 (23)	23 (25)	26 (28)	29 (31)	32 (34)	34 (36)	-	-	-	-	-	-	-	-	-	-	-
CSL-BC12	29 (32)	33 (36)	38 (41)	42 (45)	46 (49)	50 (53)	55 (58)	59 (62)	63 (66)	67 (70)	-	-	-	-	-	-	-
CSL-BC16	44 (49)	49 (54)	55 (60)	61 (66)	67 (72)	72 (77)	78 (83)	84 (89)	90 (95)	95 (100)	-	-	-	-	-	-	-
CSL-BC20	86 (96)	84 (94)	93 (103)	102 (112)	111 (121)	120 (130)	129 (139)	137 (147)	146 (156)	155 (165)	164 (174)	173 (183)	190 (200)	199 (209)	208 (218)	226 (236)	243 (253)
CSL-BC25	126 (142)	122 (138)	134 (150)	146 (162)	159 (175)	171 (187)	183 (199)	195 (211)	207 (223)	219 (235)	231 (247)	243 (259)	267 (283)	280 (296)	292 (308)	316 (332)	340 (356)
CSL-BC32	-	222 (262)	242 (282)	262 (302)	283 (323)	303 (343)	323 (363)	343 (383)	363 (403)	383 (423)	403 (443)	423 (463)	464 (504)	484 (524)	504 (544)	544 (584)	584 (624)
CSL-BC40	-	316 (356)	339 (379)	362 (402)	386 (426)	409 (449)	433 (473)	456 (496)	479 (519)	502 (542)	526 (566)	549 (589)	596 (636)	619 (659)	642 (682)	689 (729)	735 (775)
CSL-BC50	-	545 (640)	580 (675)	614 (709)	649 (744)	683 (778)	718 (813)	752 (847)	786 (881)	820 (915)	855 (950)	889 (984)	958 (1053)	993 (1088)	1027 (1122)	1096 (1191)	1164 (1259)
CSL-BC63	-	832 (927)	872 (967)	912 (1007)	952 (1047)	991 (1086)	1031 (1126)	1071 (1166)	1111 (1206)	1150 (1245)	1190 (1285)	1230 (1325)	1310 (1405)	1350 (1445)	1389 (1484)	1469 (1564)	1548 (1643)

Values in () parentheses are masses for male thread specifications

unit: oz

Model	Stroke mm [in]																
	5 [0.197]	10 [0.394]	15 [0.591]	20 [0.787]	25 [0.984]	30 [1.181]	35 [1.378]	40 [1.575]	45 [1.772]	50 [1.969]	55 [2.165]	60 [2.362]	70 [2.756]	75 [2.953]	80 [3.150]	90 [3.543]	100 [3.9]
CSL-BC6	0.459 (0.529)	0.564 (0.635)	0.705 (0.776)	0.811 (0.882)	0.952 (1.023)	1.058 (1.129)	-	-	-	-	-	-	-	-	-	-	-
CSL-BC8	0.670 (0.741)	0.741 (0.811)	0.847 (0.917)	0.952 (1.023)	1.093 (1.129)	1.129 (1.199)	-	-	-	-	-	-	-	-	-	-	-
CSL-BC10	0.741 (0.811)	0.811 (0.882)	0.917 (0.988)	1.023 (1.093)	1.129 (1.199)	1.199 (1.270)	-	-	-	-	-	-	-	-	-	-	-
CSL-BC12	1.023 (1.129)	1.164 (1.270)	1.340 (1.446)	1.482 (1.587)	1.623 (1.728)	1.764 (1.870)	1.940 (2.046)	2.081 (2.187)	2.222 (2.328)	2.363 (2.469)	-	-	-	-	-	-	-
CSL-BC16	1.552 (1.728)	1.728 (1.905)	1.940 (2.116)	2.152 (2.328)	2.363 (2.540)	2.540 (2.716)	2.751 (2.928)	2.963 (3.139)	3.175 (3.351)	3.351 (3.5)	-	-	-	-	-	-	-
CSL-BC20	3.034 (3.386)	2.963 (3.316)	3.280 (3.6)	3.6 (4.0)	3.9 (4.3)	4.2 (4.6)	4.6 (4.9)	4.8 (5.2)	5.1 (5.5)	5.5 (5.8)	5.8 (6.1)	6.1 (6.5)	6.7 (7.1)	7.0 (7.4)	7.3 (7.7)	8.0 (8.3)	8.6 (8.9)
CSL-BC25	4.4 (5.0)	4.3 (4.9)	4.7 (5.3)	5.1 (5.7)	5.6 (6.2)	6.0 (6.6)	6.5 (7.0)	6.9 (7.4)	7.3 (7.9)	7.7 (8.3)	8.1 (8.7)	8.6 (9.1)	9.4 (10.0)	9.9 (10.4)	10.3 (10.9)	11.1 (11.7)	12.0 (12.6)
CSL-BC32	-	7.8 (9.2)	8.5 (9.9)	9.2 (10.7)	10.0 (11.4)	10.7 (12.1)	11.4 (12.8)	12.1 (13.5)	12.8 (14.2)	13.5 (14.9)	14.2 (15.6)	14.9 (16.3)	16.4 (17.8)	17.1 (18.5)	17.8 (19.2)	19.2 (20.6)	20.6 (22.0)
CSL-BC40	-	11.1 (12.6)	12.0 (13.4)	12.8 (14.2)	13.6 (15.0)	14.4 (15.8)	15.3 (16.7)	16.1 (17.5)	16.9 (18.3)	17.7 (19.1)	18.6 (20.0)	19.4 (20.8)	21.0 (22.4)	21.8 (23.2)	22.6 (24.1)	24.3 (25.7)	25.9 (27.3)
CSL-BC50	-	19.2 (22.6)	20.5 (23.8)	21.7 (25.0)	22.9 (26.2)	24.1 (27.4)	25.3 (28.7)	26.5 (29.9)	27.7 (31.1)	28.9 (32.3)	30.2 (33.5)	31.4 (34.7)	33.8 (37)	35.0 (38)	36 (40)	39 (42)	41 (44)
CSL-BC63	-	29.3 (32.7)	30.8 (34.1)	32.2 (36)	33.6 (37)	35.0 (38)	36 (40)	38 (41)	39 (43)	41 (44)	42 (45)	43 (47)	46 (50)	48 (51)	49 (52)	52 (55)	55 (58)

Values in () parentheses are masses for male thread specifications

● **Double acting type (clean room specification, with dust collection port)**

unit: g

Model	Stroke mm [in]																
	5 [0.197]	10 [0.394]	15 [0.591]	20 [0.787]	25 [0.984]	30 [1.181]	35 [1.378]	40 [1.575]	45 [1.772]	50 [1.969]	55 [2.165]	60 [2.362]	70 [2.756]	75 [2.953]	80 [3.150]	90 [3.543]	100 [3.9]
CS-BC10	29 (31)	31 (33)	34 (36)	37 (39)	40 (42)	42 (44)	-	-	-	-	-	-	-	-	-	-	-
CS-BC12	43 (46)	47 (50)	52 (55)	56 (59)	60 (63)	64 (67)	69 (72)	73 (76)	77 (80)	81 (84)	-	-	-	-	-	-	-
CS-BC16	61 (66)	66 (71)	72 (77)	78 (83)	84 (89)	89 (94)	95 (100)	101 (106)	107 (112)	112 (117)	-	-	-	-	-	-	-
CS-BC20	111 (121)	109 (119)	118 (128)	127 (137)	136 (146)	145 (155)	154 (164)	162 (172)	171 (181)	180 (190)	189 (199)	198 (208)	215 (225)	224 (234)	233 (243)	251 (261)	268 (278)
CS-BC25	162 (178)	158 (174)	170 (186)	182 (198)	195 (211)	207 (223)	219 (235)	231 (247)	243 (259)	255 (271)	267 (283)	279 (295)	303 (319)	316 (332)	328 (344)	352 (368)	376 (392)
CS-BC32	-	306 (346)	326 (366)	346 (386)	367 (407)	387 (427)	407 (447)	427 (467)	447 (487)	467 (507)	487 (527)	507 (547)	548 (588)	568 (608)	588 (628)	628 (668)	668 (708)
CS-BC40	-	437 (477)	460 (500)	483 (523)	507 (547)	530 (570)	554 (594)	577 (617)	600 (640)	623 (663)	647 (687)	670 (710)	717 (757)	740 (780)	763 (803)	810 (850)	856 (896)
CS-BC50	-	740 (835)	775 (870)	809 (904)	844 (939)	878 (973)	913 (1008)	947 (1042)	981 (1076)	1015 (1110)	1050 (1145)	1084 (1179)	1153 (1248)	1188 (1283)	1222 (1317)	1291 (1386)	1359 (1454)
CS-BC63	-	1174 (1269)	1214 (1309)	1254 (1349)	1294 (1389)	1333 (1428)	1373 (1468)	1413 (1508)	1453 (1548)	1492 (1587)	1532 (1627)	1572 (1667)	1652 (1747)	1692 (1787)	1731 (1826)	1811 (1906)	1890 (1985)

Values in () parentheses are masses for male thread specifications

unit: oz

Model	Stroke mm [in]																
	5 [0.197]	10 [0.394]	15 [0.591]	20 [0.787]	25 [0.984]	30 [1.181]	35 [1.378]	40 [1.575]	45 [1.772]	50 [1.969]	55 [2.165]	60 [2.362]	70 [2.756]	75 [2.953]	80 [3.150]	90 [3.543]	100 [3.9]
CS-BC10	1.023 (1.093)	1.093 (1.164)	1.199 (1.270)	1.305 (1.376)	1.411 (1.482)	1.482 (1.552)	-	-	-	-	-	-	-	-	-	-	-
CS-BC12	1.517 (1.623)	1.658 (1.764)	1.834 (1.940)	1.975 (2.081)	2.116 (2.222)	2.258 (2.363)	2.434 (2.540)	2.575 (2.681)	2.716 (2.822)	2.857 (2.963)	-	-	-	-	-	-	-
CS-BC16	2.152 (2.328)	2.328 (2.504)	2.540 (2.716)	2.751 (2.928)	2.963 (3.139)	3.139 (3.316)	3.351 (3.5)	3.6 (3.7)	3.8 (4.0)	4.0 (4.1)	-	-	-	-	-	-	-
CS-BC20	3.9 (4.3)	3.8 (4.2)	4.2 (4.5)	4.5 (4.8)	4.8 (5.1)	5.1 (5.5)	5.4 (5.8)	5.7 (6.1)	6.0 (6.4)	6.3 (6.7)	6.7 (7.0)	7.0 (7.3)	7.6 (7.9)	7.9 (8.3)	8.2 (8.6)	8.9 (9.2)	9.5 (9.8)
CS-BC25	5.7 (6.3)	5.6 (6.1)	6.0 (6.6)	6.4 (7.0)	6.9 (7.4)	7.3 (7.9)	7.7 (8.3)	8.1 (8.7)	8.6 (9.1)	9.0 (9.6)	9.4 (10.0)	9.8 (10.4)	10.7 (11.3)	11.1 (11.7)	11.6 (12.1)	12.4 (13.0)	13.3 (13.8)
CS-BC32	-	10.8 (12.2)	11.5 (12.9)	12.2 (13.6)	12.9 (14.4)	13.7 (15.1)	14.4 (15.8)	15.1 (16.5)	15.8 (17.2)	16.5 (17.9)	17.2 (18.6)	17.9 (19.3)	19.3 (20.7)	20.0 (21.4)	20.7 (22.2)	22.2 (23.6)	23.6 (25.0)
CS-BC40	-	15.4 (16.8)	16.2 (17.6)	17.0 (18.4)	17.9 (19.3)	18.7 (20.1)	19.5 (21.0)	20.4 (21.8)	21.2 (22.6)	22.0 (23.4)	22.8 (24.2)	23.6 (25.0)	25.3 (26.7)	26.1 (27.5)	26.9 (28.3)	28.6 (30.0)	30.2 (31.6)
CS-BC50	-	26.1 (29.5)	27.3 (30.7)	28.5 (31.9)	29.8 (33.1)	31.0 (34.3)	32.2 (36)	33.4 (37)	34.6 (38)	36 (39)	37 (40)	38 (42)	41 (44)	42 (45)	43 (46)	46 (49)	48 (51)
CS-BC63	-	41 (45)	43 (46)	44 (48)	46 (49)	47 (50)	48 (52)	50 (53)	51 (55)	53 (56)	54 (57)	55 (59)	58 (62)	60 (63)	61 (64)	64 (67)	67 (70)

Values in () parentheses are masses for male thread specifications

● **Additional mass of sensor switches**

ZE□□□A, ZE□□□G: 15 g [0.529 oz] ZE□□□B: 35 g [1.235 oz]

Inner construction

Double acting type (clean room specification)

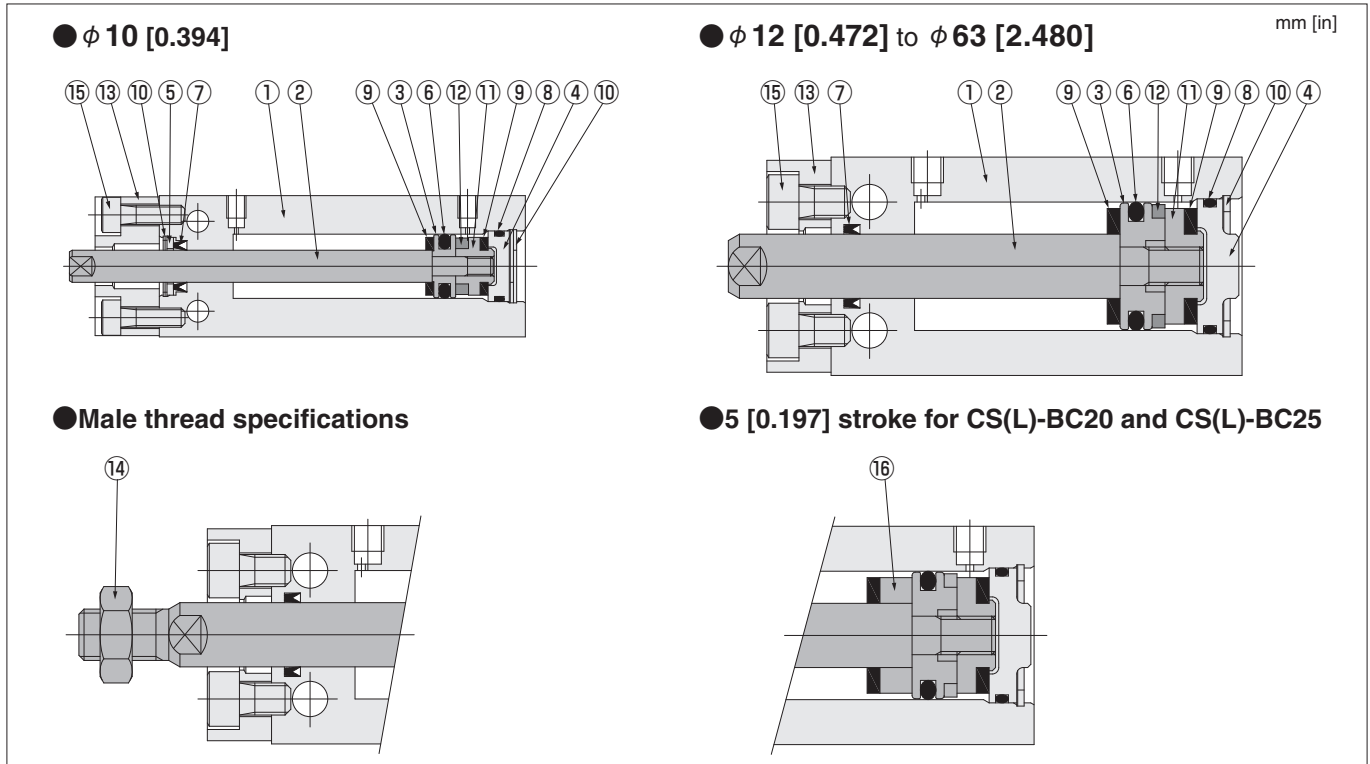

Major parts and materials (clean room specification)

No.	Name	φ 6 ^{Note 1} [0.236]	φ 8 ^{Note 1} [0.315]	φ 10 [0.394]	φ 12 [0.472]	φ 16 [0.630]	φ 20 [0.787]	φ 25 [0.984]	φ 32 [1.260]	φ 40 [1.575]	φ 50 [1.969]	φ 63 [2.480]
①	Cylinder body	Aluminum alloy (special anti-abrasion treated)										
②	Piston rod	Stainless steel										
③	Piston	Stainless steel					Aluminum alloy (anodized)					
④	Head cover	Aluminum alloy (anodized)										
⑤	Seal holder	Aluminum alloy (anodized)	—	—	—	—	—	—	—	—	—	—
⑥	★Piston seal	Synthetic rubber (NBR)										
⑦	★Rod seal	Synthetic rubber (NBR)										
⑧	★O-ring	Synthetic rubber (NBR)										
⑨	Bumper	Synthetic rubber (NBR)										
⑩	★Retaining ring	Stainless steel ^{Note 2}			Steel (electroless nickel plated)							
⑪	Support	Stainless steel	Aluminum alloy (anodized)									
⑫	Magnet	Neodymium magnet							Plastic magnet			
⑬	Rod cover (with dust collection port) ^{Note 4}	—	—	Aluminum alloy (anodized)								
⑭	Rod end nut	Stainless steel										
⑮	Bolt	Stainless steel										
⑯	Stopper ^{Note 3}	—	—	—	—	—	Aluminum alloy (anodized)	—	—	—	—	

Items indicated by a ★ are available as additional parts or in packing sets. For order codes, see page 103.

Note 1: With dust collection port not available for cylinder bores φ 6 [0.236] and φ 8 [0.315].

2: φ 6 [0.236] head cover side is steel (electroless nickel plated).

3: Only stroke 5 [0.197] has a collar stopper.

4: Without dust collection port and with dust collection port are available for φ 10 [0.394] to φ 63 [2.480]. For information about the internal structure (shape) of without dust collection port types, see the double acting type diagrams on page 103.

Dimensions of without dust collection port types are the same as those for the standard specification. Refer to page 33.

● CS-BC10 (clean room specification, with dust collection port)

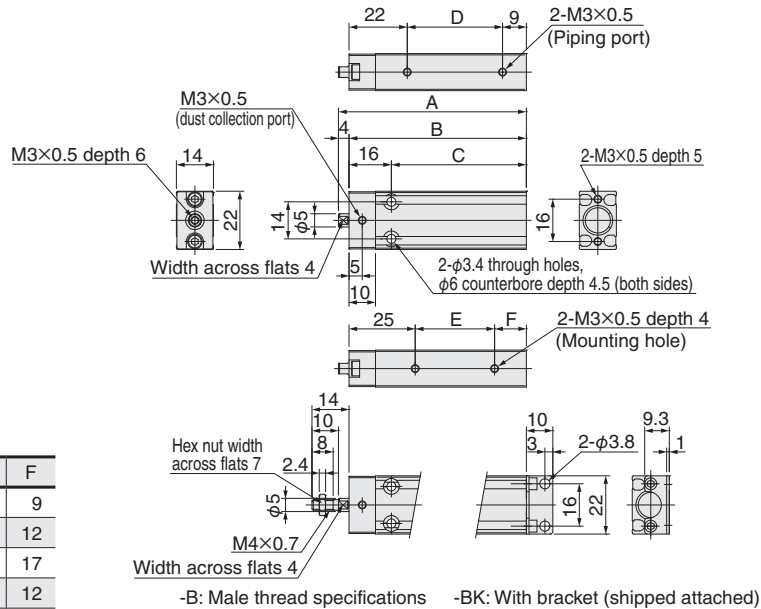

Stroke	A	B	C	D	E	F
5	46	42	26	11	8	9
10	51	47	31	16	10	12
15	56	52	36	21	10	17
20	61	57	41	26	20	12
25	66	62	46	31	20	17
30	71	67	51	36	30	12

Note: This product cannot use reed switch type sensor switches.

● CS-BC12 (clean room specification, with dust collection port)

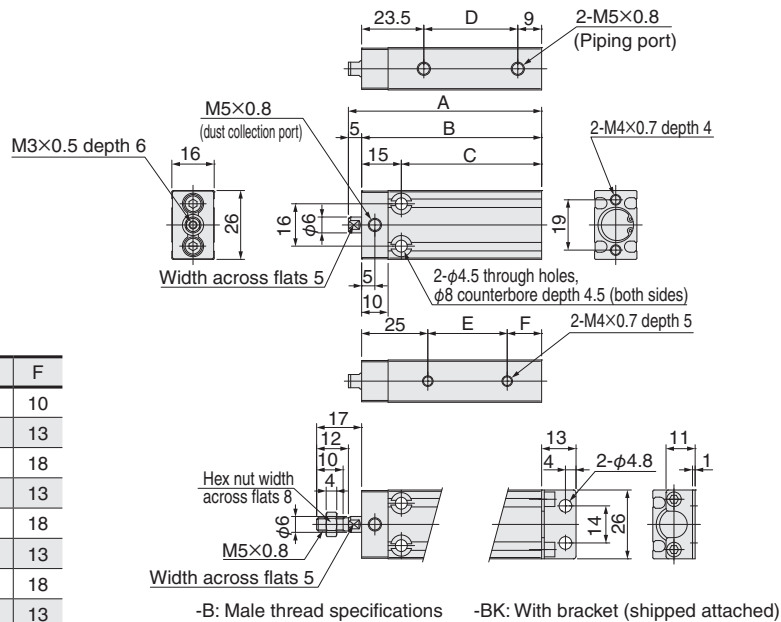

Stroke	A	B	C	D	E	F
5	48	43	28	10.5	8	10
10	53	48	33	15.5	10	13
15	58	53	38	20.5	10	18
20	63	58	43	25.5	20	13
25	68	63	48	30.5	20	18
30	73	68	53	35.5	30	13
35	78	73	58	40.5	30	18
40	83	78	63	45.5	40	13
45	88	83	68	50.5	40	18
50	93	88	73	55.5	50	13

Note: This product cannot use reed switch type sensor switches.

Dimensions of without dust collection port types are the same as those for the standard specification. Refer to page 34.

● CS-BC10 (clean room specification, with dust collection port)

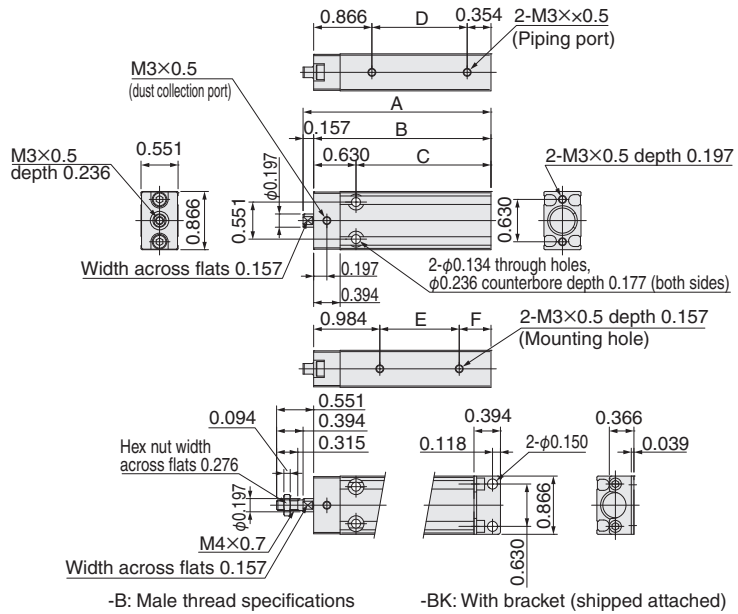

Stroke	A	B	C	D	E	F
5 mm [0.197]	1.811	1.654	1.024	0.433	0.315	0.354
10 mm [0.394]	2.008	1.850	1.220	0.630	0.394	0.472
15 mm [0.591]	2.205	2.047	1.417	0.827	0.394	0.669
20 mm [0.787]	2.402	2.244	1.614	1.024	0.787	0.472
25 mm [0.984]	2.598	2.441	1.811	1.220	0.787	0.669
30 mm [1.181]	2.795	2.638	2.008	1.417	1.181	0.472

Note: This product cannot use reed switch type sensor switches.

● CS-BC12 (clean room specification, with dust collection port)

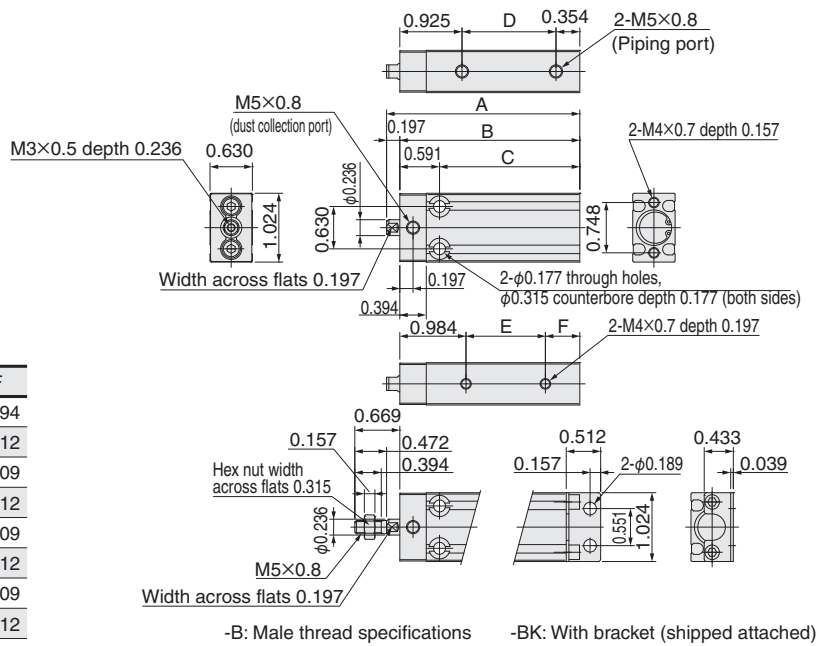

Stroke	A	B	C	D	E	F
5 mm [0.197]	1.890	1.693	1.102	0.413	0.315	0.394
10 mm [0.394]	2.087	1.890	1.299	0.610	0.394	0.512
15 mm [0.591]	2.283	2.087	1.496	0.807	0.394	0.709
20 mm [0.787]	2.480	2.283	1.693	1.004	0.787	0.512
25 mm [0.984]	2.677	2.480	1.890	1.201	0.787	0.709
30 mm [1.181]	2.874	2.677	2.087	1.398	1.181	0.512
35 mm [1.378]	3.071	2.874	2.283	1.594	1.181	0.709
40 mm [1.575]	3.268	3.071	2.480	1.791	1.575	0.512
45 mm [1.772]	3.465	3.268	2.677	1.988	1.575	0.709
50 mm [1.969]	3.661	3.465	2.874	2.185	1.969	0.512

Note: This product cannot use reed switch type sensor switches.

Dimensions of without dust collection port types are the same as those for the standard specification. Refer to page 35.

● CS-BC16 (clean room specification, with dust collection port)

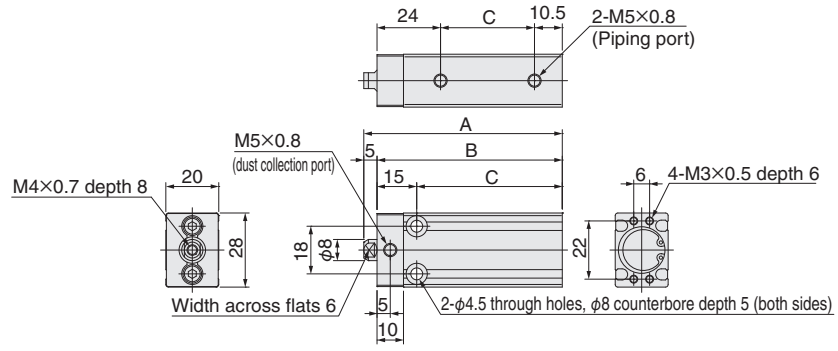

Stroke	A	B	C	D	E	F
5	50	45	30	10.5	10	10
10	55	50	35	15.5	10	15
15	60	55	40	20.5	10	20
20	65	60	45	25.5	20	15
25	70	65	50	30.5	20	20
30	75	70	55	35.5	30	15
35	80	75	60	40.5	30	20
40	85	80	65	45.5	40	15
45	90	85	70	50.5	40	20
50	95	90	75	55.5	50	15

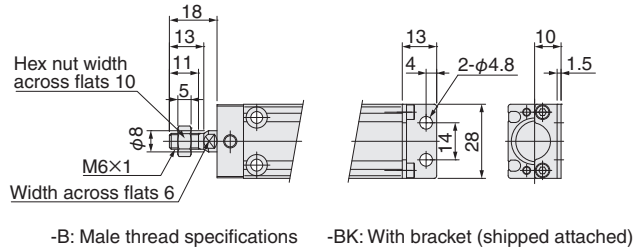

-B: Male thread specifications -BK: With bracket (shipped attached)

● CS-BC20 (clean room specification, with dust collection port)

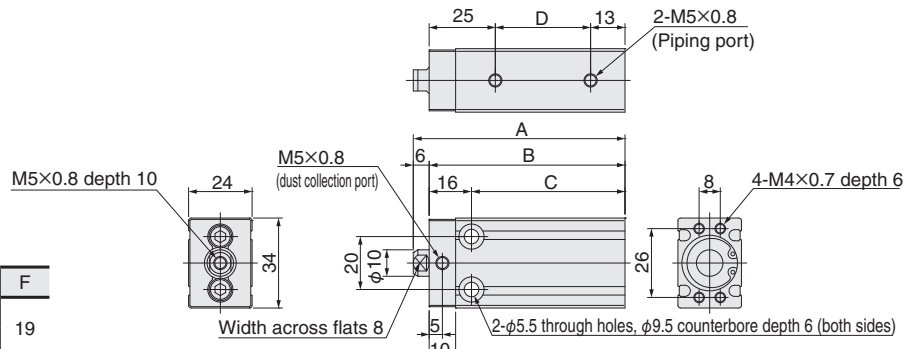

Stroke	A	B	C	D	E	F
5						
10	60	54	38	16	10	19
15	65	59	43	21	10	24
20	70	64	48	26	20	19
25	75	69	53	31	20	24
30	80	74	58	36	30	19
35	85	79	63	41	30	24
40	90	84	68	46	40	19
45	95	89	73	51	40	24
50	100	94	78	56	50	19
55	105	99	83	61	50	24
60	110	104	88	66	50	29
70	120	114	98	76	70	19
75	125	119	103	81	70	24
80	130	124	108	86	70	29
90	140	134	118	96	90	19
100	150	144	128	106	90	29

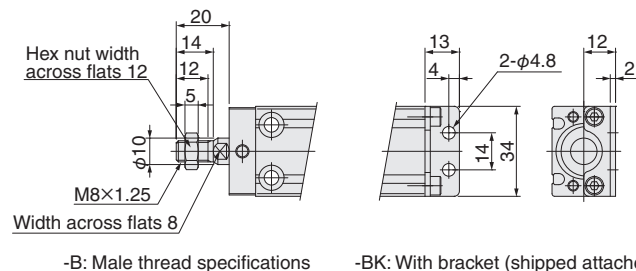

-B: Male thread specifications -BK: With bracket (shipped attached)

Note: 5 stroke supports collar stopper.

Dimensions of without dust collection port types are the same as those for the standard specification. Refer to page 36 .

● CS-BC16 (clean room specification, with dust collection port)

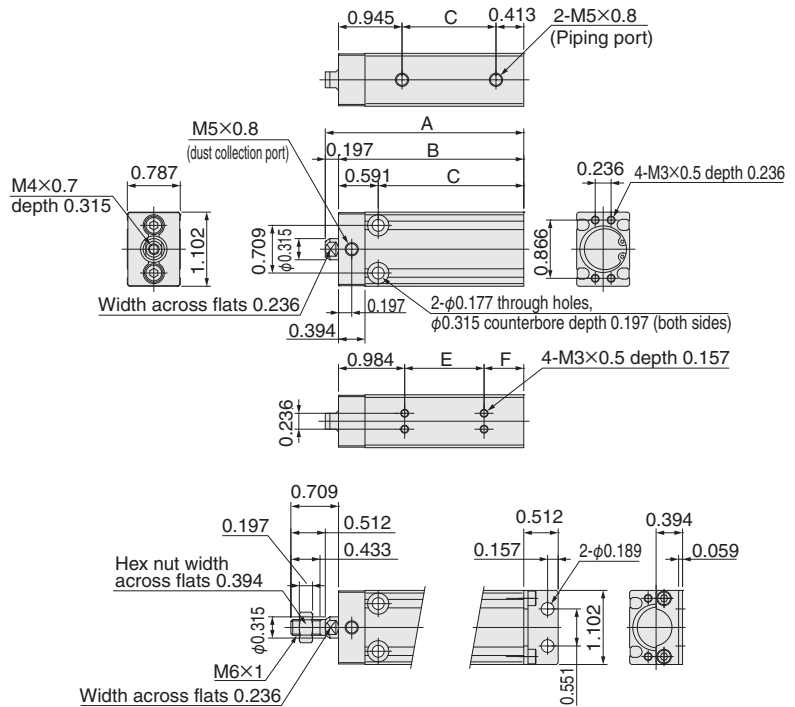

Stroke	A	B	C	D	E	F
5 mm [0.197]	1.969	1.772	1.181	0.413	0.394	0.394
10 mm [0.394]	2.165	1.969	1.378	0.610	0.394	0.591
15 mm [0.591]	2.362	2.165	1.575	0.807	0.394	0.787
20 mm [0.787]	2.559	2.362	1.772	1.004	0.787	0.591
25 mm [0.984]	2.756	2.559	1.969	1.201	0.787	0.787
30 mm [1.181]	2.953	2.756	2.165	1.398	1.181	0.591
35 mm [1.378]	3.150	2.953	2.362	1.594	1.181	0.787
40 mm [1.575]	3.346	3.150	2.559	1.791	1.575	0.591
45 mm [1.772]	3.543	3.346	2.756	1.988	1.575	0.787
50 mm [1.969]	3.740	3.543	2.953	2.185	1.969	0.591

-B: Male thread specifications -BK: With bracket (shipped attached)

● CS-BC20 (clean room specification, with dust collection port)

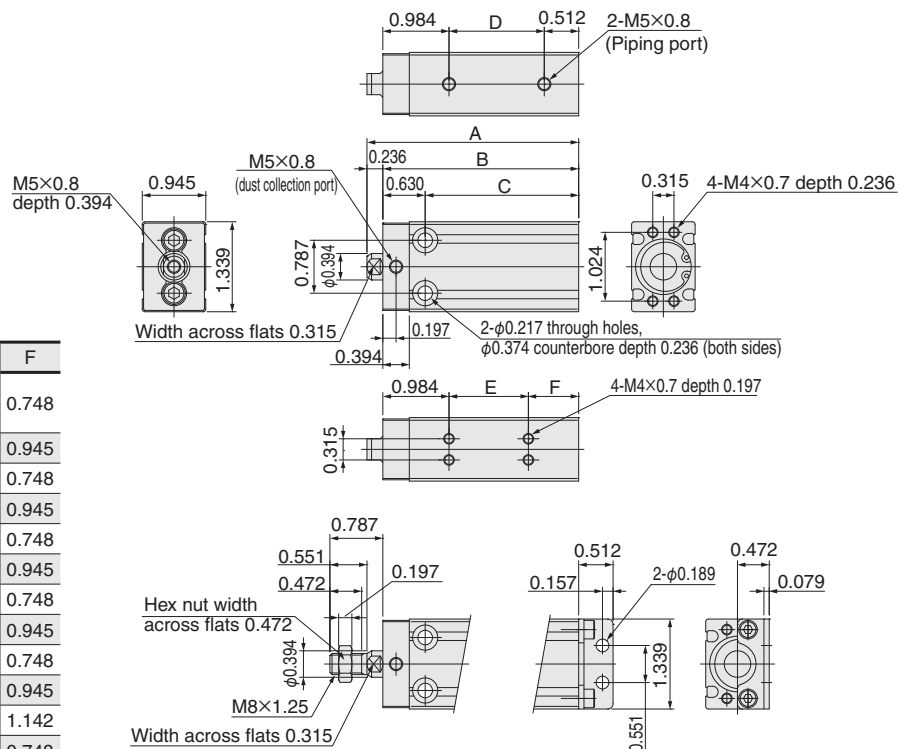

Stroke	A	B	C	D	E	F
5 mm [0.197]	2.362	2.126	1.496	0.630	0.394	0.748
10 mm [0.394]	2.559	2.323	1.693	0.827	0.394	0.945
15 mm [0.591]	2.756	2.520	1.890	1.024	0.787	0.748
20 mm [0.787]	2.953	2.717	2.087	1.220	0.787	0.945
30 mm [1.181]	3.150	2.913	2.283	1.417	1.181	0.748
35 mm [1.378]	3.346	3.110	2.480	1.614	1.181	0.945
40 mm [1.575]	3.543	3.307	2.677	1.811	1.575	0.748
45 mm [1.772]	3.740	3.504	2.874	2.008	1.575	0.945
50 mm [1.969]	3.937	3.701	3.071	2.205	1.969	0.748
55 mm [2.165]	4.134	3.898	3.268	2.402	1.969	0.945
60 mm [2.362]	4.331	4.094	3.465	2.598	1.969	1.142
70 mm [2.756]	4.724	4.488	3.858	2.992	2.756	0.748
75 mm [2.953]	4.921	4.685	4.055	3.189	2.756	0.945
80 mm [3.150]	5.118	4.882	4.252	3.386	2.756	1.142
90 mm [3.543]	5.512	5.276	4.646	3.780	3.543	0.748
100 mm [3.937]	5.906	5.669	5.039	4.173	3.543	1.142

-B: Male thread specifications -BK: With bracket (shipped attached)

Note: 0.197 stroke supports collar stopper.

Dimensions of without dust collection port types are the same as those for the standard specification. Refer to page 37.

● CS-BC25 (clean room specification, with dust collection port)

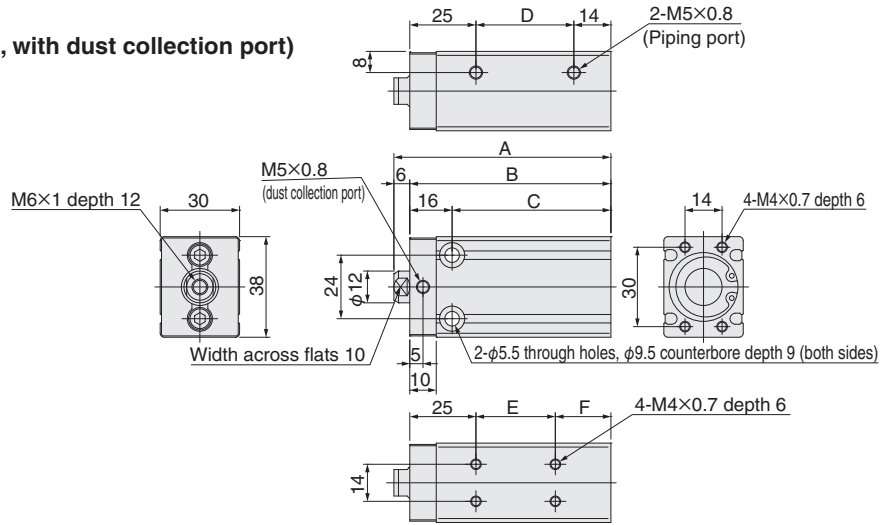

Stroke	A	B	C	D	E	F
5	62	56	40	17	10	21
10	67	61	45	22	10	26
15	72	66	50	27	20	21
20	77	71	55	32	20	26
25	82	76	60	37	30	21
30	87	81	65	42	30	26
35	92	86	70	47	40	21
40	97	91	75	52	40	26
45	102	96	80	57	50	21
50	107	101	85	62	50	26
55	112	106	90	67	50	31
60	117	111	95	72	60	21
65	122	116	100	77	70	21
70	127	121	105	82	70	26
75	132	126	110	87	70	31
80	137	131	115	92	80	21
85	142	136	120	97	90	21
90	147	141	125	102	100	26
95	152	146	130	107	110	21
100	157	151	135	112	120	26

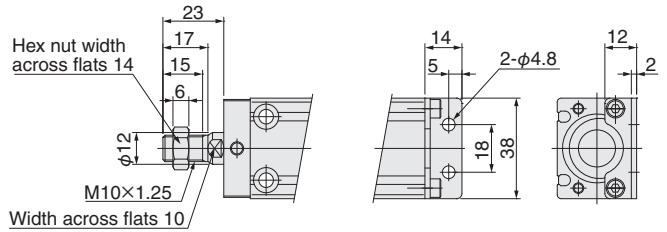

-B: Male thread specifications -BK: With bracket (shipped attached)

Note: 5 stroke supports collar stopper.

● CS-BC32 (clean room specification, with dust collection port)

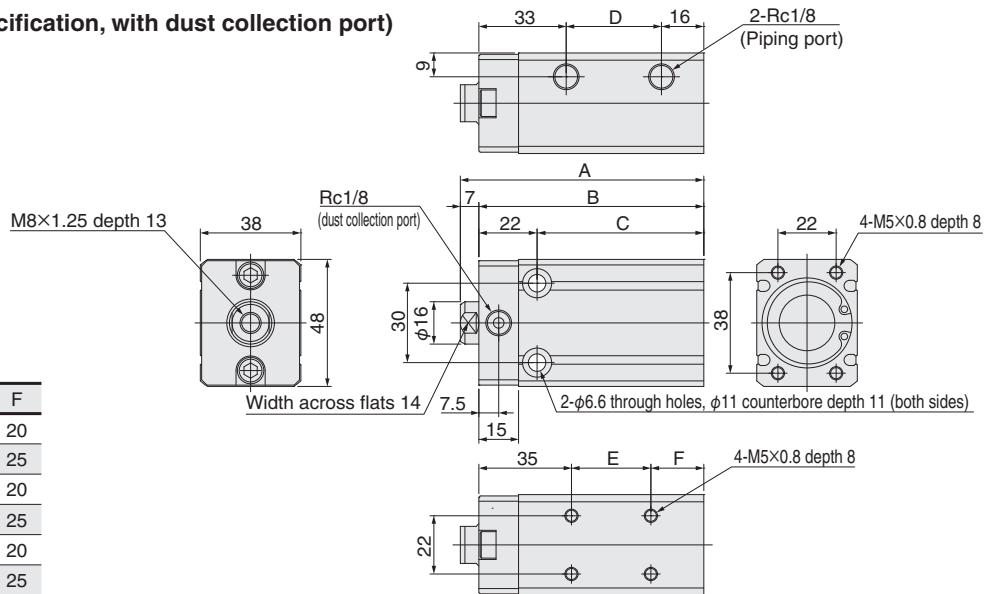

Stroke	A	B	C	D	E	F
10	72	65	43	16	10	20
15	77	70	48	21	10	25
20	82	75	53	26	20	20
25	87	80	58	31	20	25
30	92	85	63	36	30	20
35	97	90	68	41	30	25
40	102	95	73	46	40	20
45	107	100	78	51	40	25
50	112	105	83	56	50	20
55	117	110	88	61	50	25
60	122	115	93	66	50	30
65	127	120	98	71	60	20
70	132	125	103	76	70	20
75	137	130	108	81	70	25
80	142	135	113	86	80	20
85	147	140	118	91	90	20
90	152	145	123	96	100	20
95	157	150	128	101	110	20
100	162	155	133	106	120	20

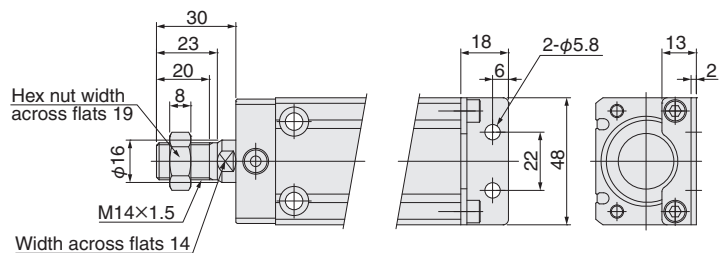

-B: Male thread specifications -BK: With bracket (shipped attached)

Dimensions of without dust collection port types are the same as those for the standard specification. Refer to page 38.

● CS-BC25 (clean room specification, with dust collection port)

Stroke	A	B	C	D	E	F
5 mm [0.197]	2.441	2.205	1.575	0.669	0.394	0.827
10 mm [0.394]	2.441	2.205	1.575	0.669	0.394	0.827
15 mm [0.591]	2.638	2.402	1.772	0.866	0.394	1.024
20 mm [0.787]	2.835	2.598	1.969	1.063	0.787	0.827
25 mm [0.984]	3.031	2.795	2.165	1.260	0.787	1.024
30 mm [1.181]	3.228	2.992	2.362	1.457	1.181	0.827
35 mm [1.378]	3.425	3.189	2.559	1.654	1.181	1.024
40 mm [1.575]	3.622	3.386	2.756	1.850	1.575	0.827
45 mm [1.772]	3.819	3.583	2.953	2.047	1.575	1.024
50 mm [1.969]	4.016	3.780	3.150	2.244	1.969	0.827
55 mm [2.165]	4.213	3.976	3.346	2.441	1.969	1.024
60 mm [2.362]	4.409	4.173	3.543	2.638	1.969	1.220
70 mm [2.756]	4.803	4.567	3.937	3.031	2.756	0.827
75 mm [2.953]	5.000	4.764	4.134	3.228	2.756	1.024
80 mm [3.150]	5.197	4.961	4.331	3.425	2.756	1.220
90 mm [3.543]	5.591	5.354	4.724	3.819	3.543	0.827
100 mm [3.937]	5.984	5.748	5.118	4.213	3.543	1.220

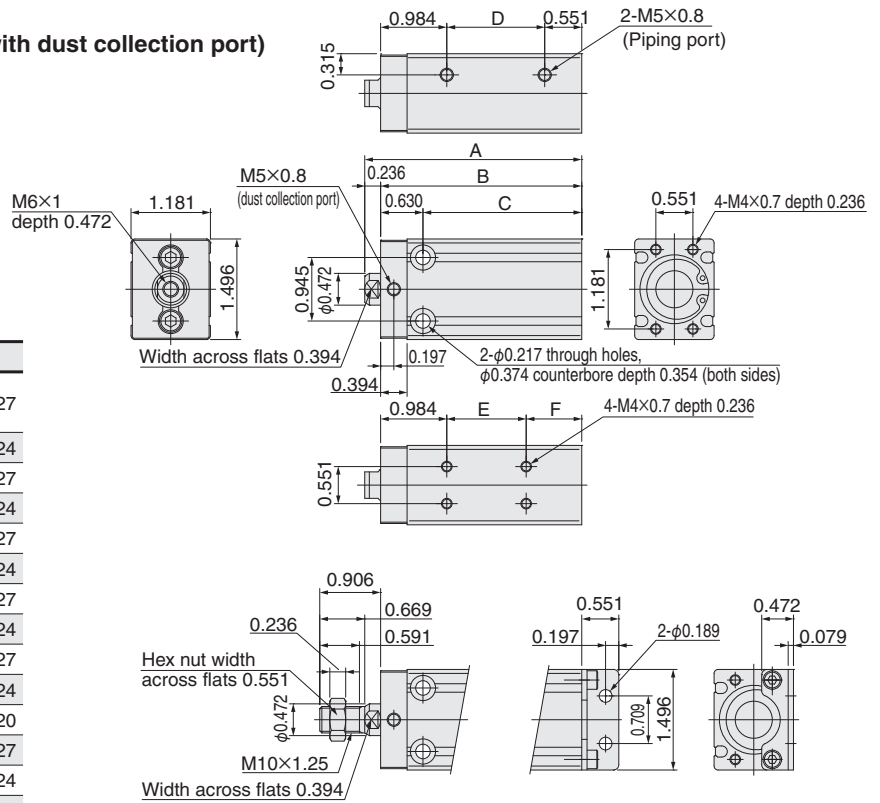

-B: Male thread specifications -BK: With bracket (shipped attached)

Note: 0.197 stroke supports collar stopper.

● CS-BC32 (clean room specification, with dust collection port)

Stroke	A	B	C	D	E	F
10 mm [0.394]	2.835	2.559	1.693	0.630	0.394	0.787
15 mm [0.591]	3.031	2.756	1.890	0.827	0.394	0.984
20 mm [0.787]	3.228	2.953	2.087	1.024	0.787	0.787
25 mm [0.984]	3.425	3.150	2.283	1.220	0.787	0.984
30 mm [1.181]	3.622	3.346	2.480	1.417	1.181	0.787
35 mm [1.378]	3.819	3.543	2.677	1.614	1.181	0.984
40 mm [1.575]	4.016	3.740	2.874	1.811	1.575	0.787
45 mm [1.772]	4.213	3.937	3.071	2.008	1.575	0.984
50 mm [1.969]	4.409	4.134	3.268	2.205	1.969	0.787
55 mm [2.165]	4.606	4.331	3.465	2.402	1.969	0.984
60 mm [2.362]	4.803	4.528	3.661	2.598	1.969	1.181
70 mm [2.756]	5.197	4.921	4.055	2.992	2.756	0.787
75 mm [2.953]	5.394	5.118	4.252	3.189	2.756	0.984
80 mm [3.150]	5.591	5.315	4.449	3.386	3.150	0.787
90 mm [3.543]	5.984	5.709	4.843	3.780	3.150	1.181
100 mm [3.937]	6.378	6.102	5.236	4.173	3.937	0.787

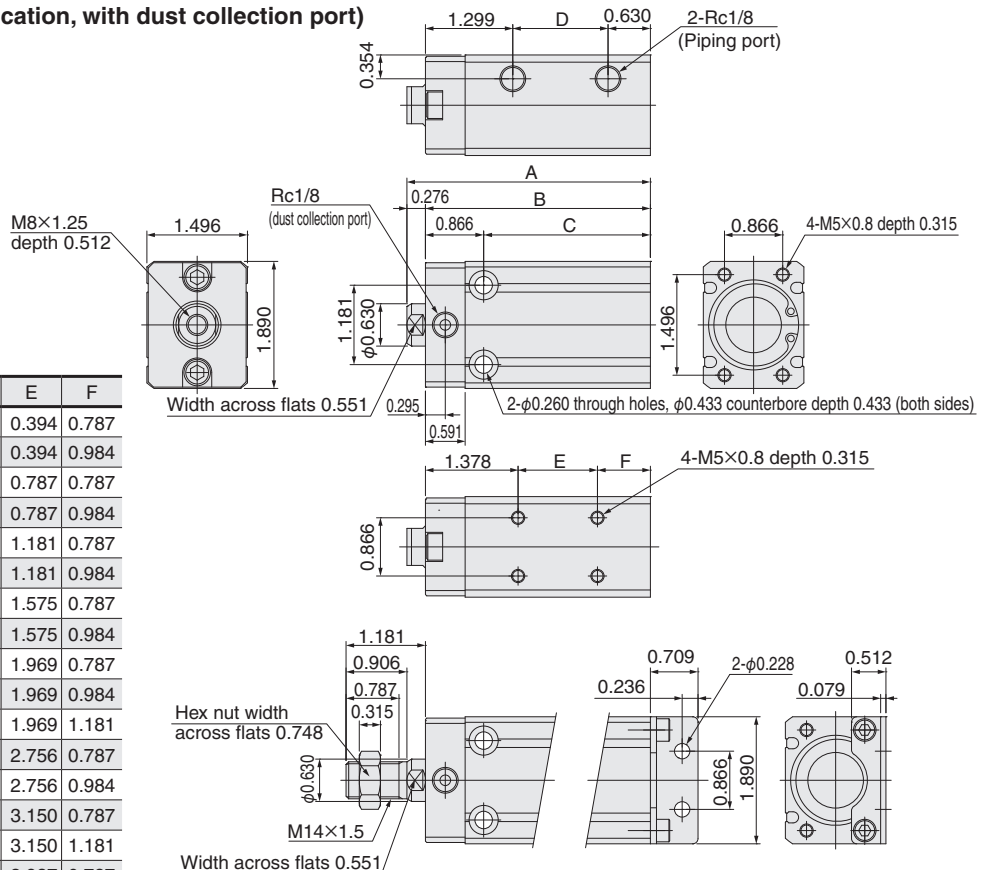

-B: Male thread specifications -BK: With bracket (shipped attached)

Dimensions of without dust collection port types are the same as those for the standard specification. Refer to page 39 .

● CS-BC40 (clean room specification, with dust collection port)

Stroke	A	B	C	D	E	F
10	79	72	48	17	15	27
15	84	77	53	22	15	32
20	89	82	58	27	20	27
25	94	87	63	32	20	32
30	99	92	68	37	30	27
35	104	97	73	42	30	32
40	109	102	78	47	40	27
45	114	107	83	52	40	32
50	119	112	88	57	50	27
55	124	117	93	62	50	32
60	129	122	98	67	60	27
70	139	132	108	77	70	27
75	144	137	113	82	70	32
80	149	142	118	87	80	27
90	159	152	128	97	80	37
100	169	162	138	107	100	27

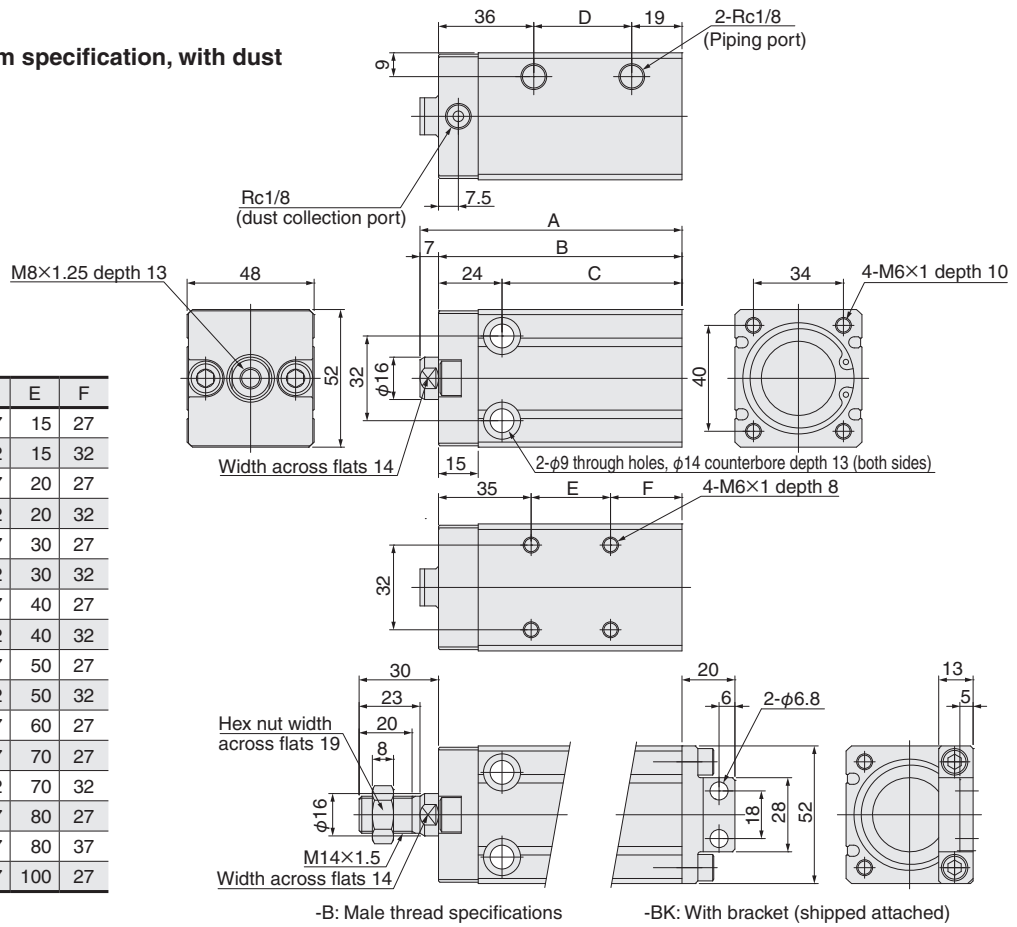

● CS-BC50 (clean room specification, with dust collection port)

Stroke	A	B	C	D
10	86	78	52	18
15	91	83	57	23
20	96	88	62	28
25	101	93	67	33
30	106	98	72	38
35	111	103	77	43
40	116	108	82	48
45	121	113	87	53
50	126	118	92	58
55	131	123	97	63
60	136	128	102	68
70	146	138	112	78
75	151	143	117	83
80	156	148	122	88
90	166	158	132	98
100	176	168	142	108

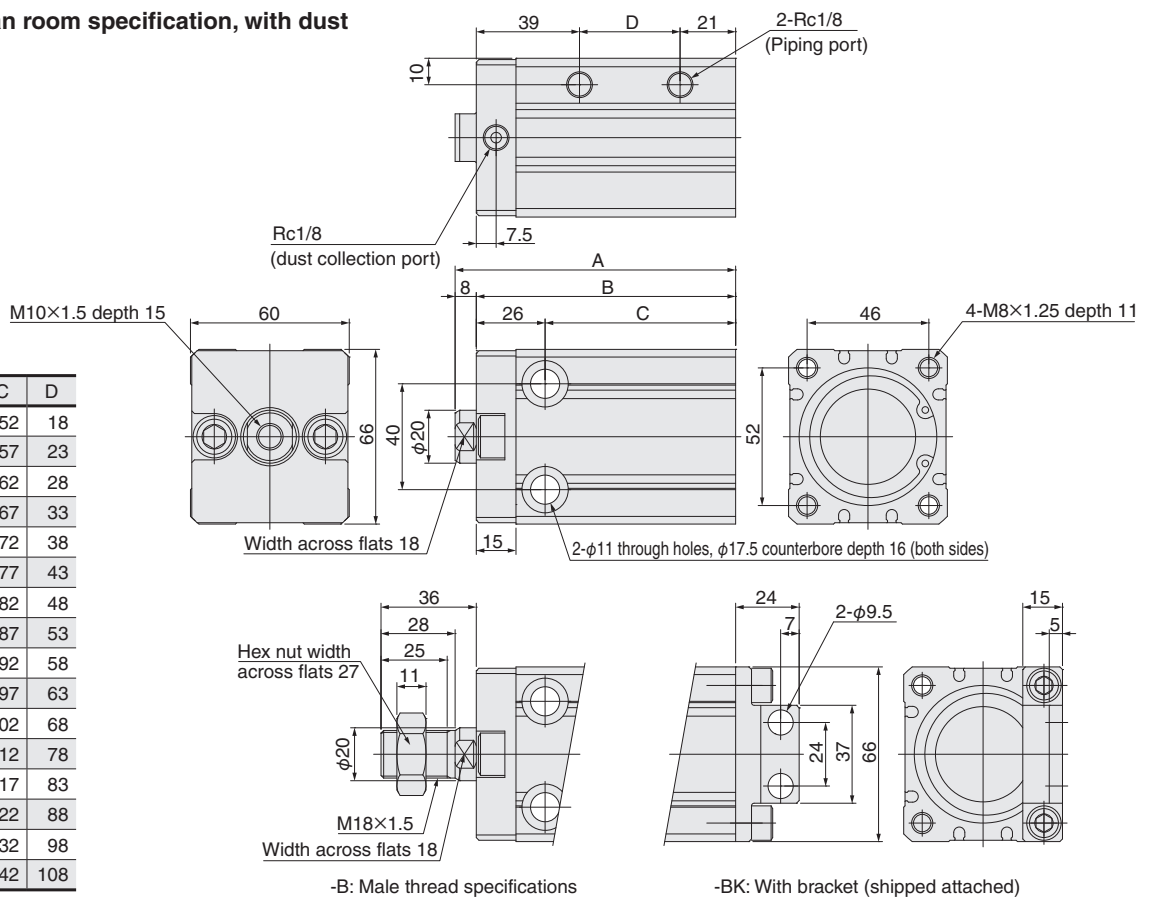

Dimensions of without dust collection port types are the same as those for the standard specification. Refer to page 40.

● CS-BC40 (clean room specification, with dust collection port)

Stroke	A	B	C	D	E	F
10 mm [0.394]	3.110	2.835	1.890	0.669	0.591	1.063
15 mm [0.591]	3.307	3.031	2.087	0.866	0.591	1.260
20 mm [0.787]	3.504	3.228	2.283	1.063	0.787	1.063
25 mm [0.984]	3.701	3.425	2.480	1.260	0.787	1.260
30 mm [1.181]	3.898	3.622	2.677	1.457	1.181	1.063
35 mm [1.378]	4.094	3.819	2.874	1.654	1.181	1.260
40 mm [1.575]	4.291	4.016	3.071	1.850	1.575	1.063
45 mm [1.772]	4.488	4.213	3.268	2.047	1.575	1.260
50 mm [1.969]	4.685	4.409	3.465	2.244	1.969	1.063
55 mm [2.165]	4.882	4.606	3.661	2.441	1.969	1.260
60 mm [2.362]	5.079	4.803	3.858	2.638	2.362	1.063
70 mm [2.756]	5.472	5.197	4.252	3.031	2.756	1.063
75 mm [2.953]	5.669	5.394	4.449	3.228	2.756	1.260
80 mm [3.150]	5.866	5.591	4.646	3.425	3.150	1.063
90 mm [3.543]	6.260	5.984	5.039	3.819	3.150	1.457
100 mm [3.937]	6.654	6.378	5.433	4.213	3.937	1.063

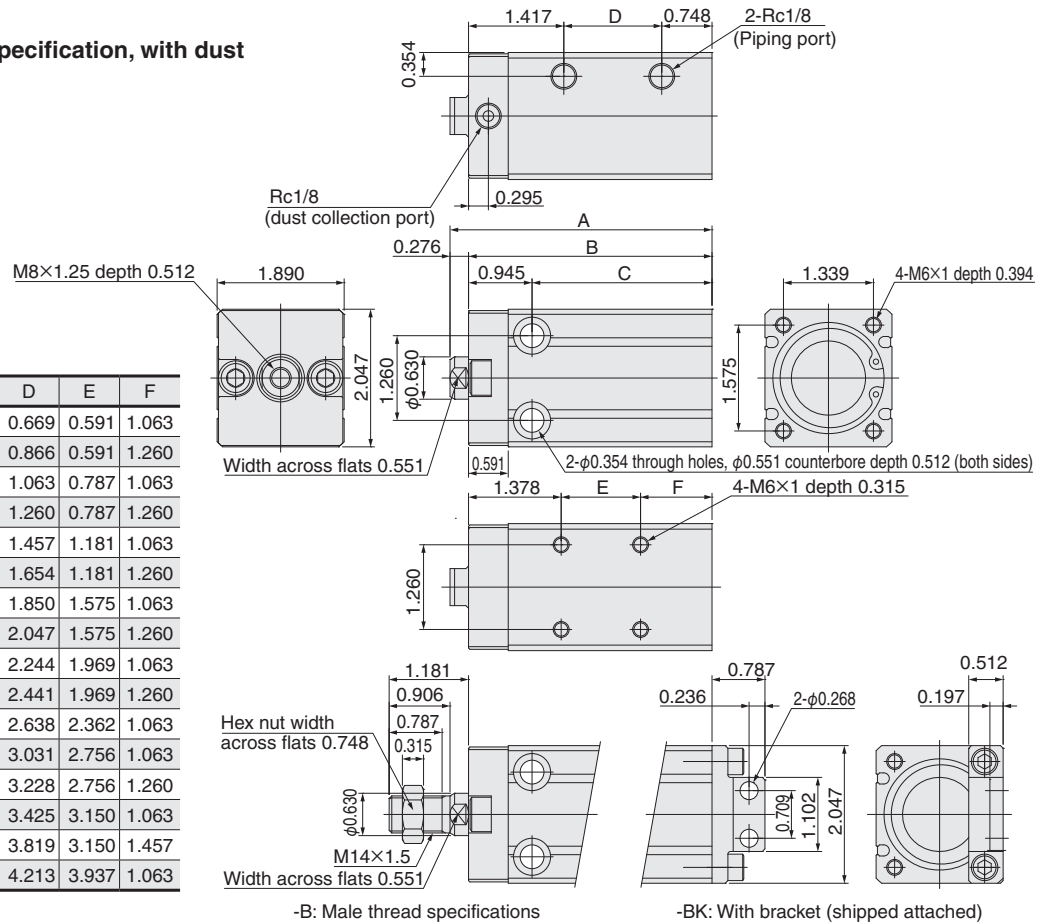

● CS-BC50 (clean room specification, with dust collection port)

Stroke	A	B	C	D
10 mm [0.394]	3.386	3.071	2.047	0.709
15 mm [0.591]	3.583	3.268	2.244	0.906
20 mm [0.787]	3.780	3.465	2.441	1.102
25 mm [0.984]	3.976	3.661	2.638	1.299
30 mm [1.181]	4.173	3.858	2.835	1.496
35 mm [1.378]	4.370	4.055	3.031	1.693
40 mm [1.575]	4.567	4.252	3.228	1.890
45 mm [1.772]	4.764	4.449	3.425	2.087
50 mm [1.969]	4.961	4.646	3.622	2.283
55 mm [2.165]	5.157	4.843	3.819	2.480
60 mm [2.362]	5.354	5.039	4.016	2.677
70 mm [2.756]	5.748	5.433	4.409	3.071
75 mm [2.953]	5.945	5.630	4.606	3.268
80 mm [3.150]	6.142	5.827	4.803	3.465
90 mm [3.543]	6.535	6.220	5.197	3.858
100 mm [3.937]	6.929	6.614	5.591	4.252

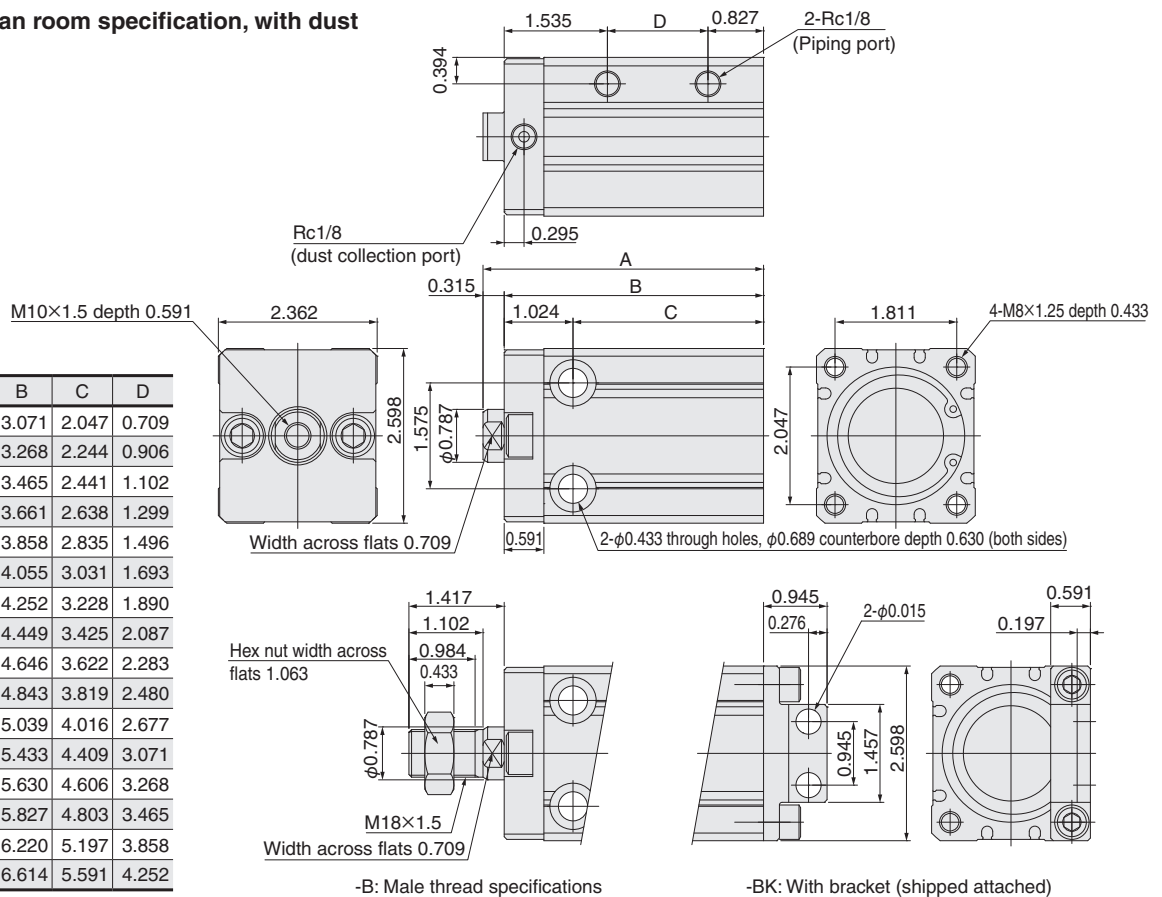

Dimensions of without dust collection port types are the same as those for the standard specification. Refer to page ④ .

● CS-BC63 (clean room specification, with dust collection port)

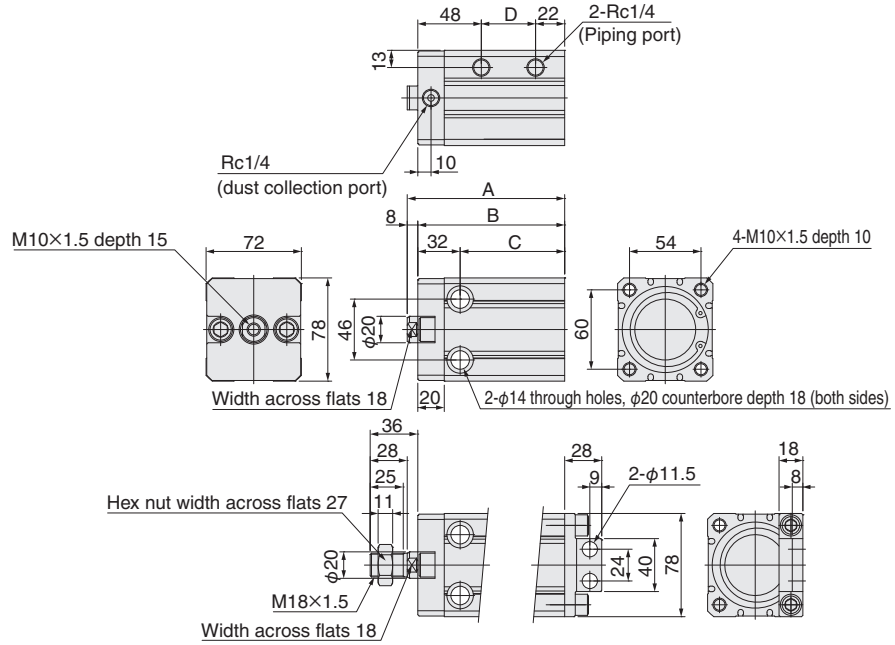

-B: Male thread specifications -BK: With bracket (shipped attached)

Stroke	A	B	C	D
10	99	91	59	21
15	104	96	64	26
20	109	101	69	31
25	114	106	74	36
30	119	111	79	41
35	124	116	84	46
40	129	121	89	51
45	134	126	94	56
50	139	131	99	61
55	144	136	104	66
60	149	141	109	71
70	159	151	119	81
75	164	156	124	86
80	169	161	129	91
90	179	171	139	101
100	189	181	149	111

Dimensions of without dust collection port types are the same as those for the standard specification. Refer to page 42 .

● CS-BC63 (clean room specification, with dust collection port)

Stroke	A	B	C	D
10 mm [0.394]	3.898	3.583	2.323	0.827
15 mm [0.591]	4.094	3.780	2.520	1.024
20 mm [0.787]	4.291	3.976	2.717	1.220
25 mm [0.984]	4.488	4.173	2.913	1.417
30 mm [1.181]	4.685	4.370	3.110	1.614
35 mm [1.378]	4.882	4.567	3.307	1.811
40 mm [1.575]	5.079	4.764	3.504	2.008
45 mm [1.772]	5.276	4.961	3.701	2.205
50 mm [1.969]	5.472	5.157	3.898	2.402
55 mm [2.165]	5.669	5.354	4.094	2.598
60 mm [2.362]	5.866	5.551	4.291	2.795
70 mm [2.756]	6.260	5.945	4.685	3.189
75 mm [2.953]	6.457	6.142	4.882	3.386
80 mm [3.150]	6.654	6.339	5.079	3.583
90 mm [3.543]	7.047	6.732	5.472	3.976
100 mm [3.937]	7.441	7.126	5.866	4.370

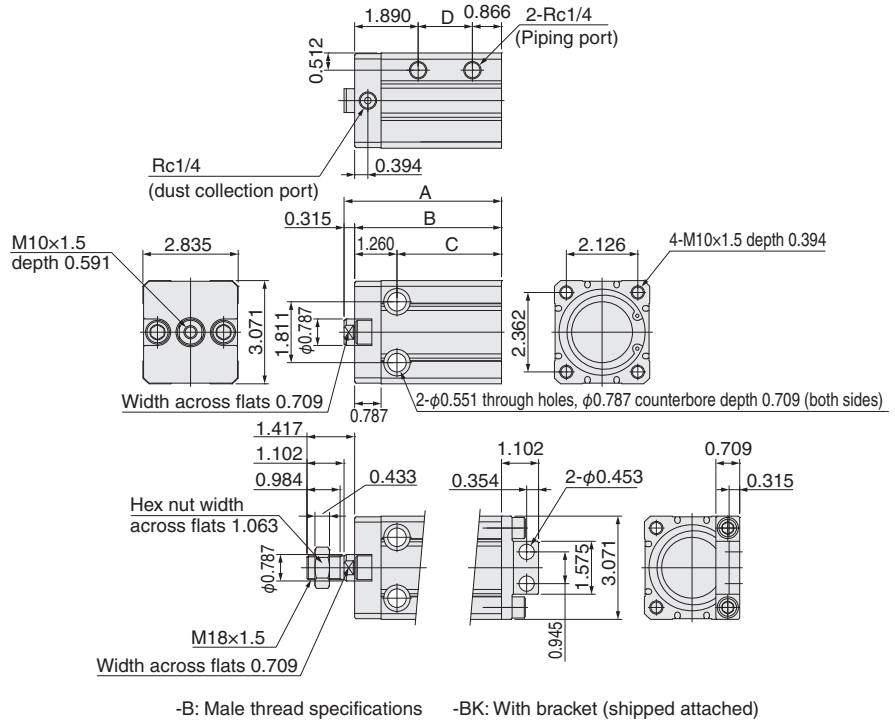

Basic Cylinders

Clean system compatible cylinders
Cylinder with guide

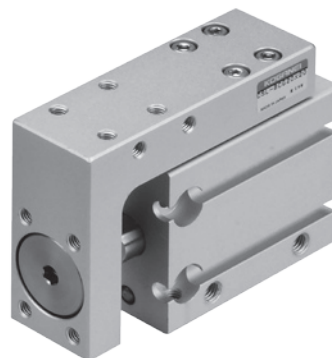

Symbol

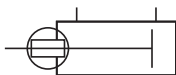

Specifications (clean room specification)

Item	Cylinder bore	8 [0.315]	12 [0.472]	16 [0.630]	20 [0.787]	25 [0.984]	32 [1.260]	40 [1.575]
Operating type		Double acting type						
Medium		Air						
Operating pressure range	MPa [psi]	0.2 to 0.7 [29 to 102]	0.1 to 0.7 [15 to 102]		0.08 to 0.7 [12 to 102]			
Proof pressure	MPa [psi]	1.05 [152]						
Operating temperature range	°C [°F]	0 to 60 [32 to 140]						
Operating speed range	mm/s [in/sec]	50 to 300 [1.969 to 11.8]						
Cushion		Rubber bumper						
Lubrication		No						
Port size		M3×0.5	M5×0.8				Rc1/8	
Running parallelism	mm [in]	0.1 [0.004] or less						
Allowable moment N·m [in·lbf]	Pitching	0.12 [1.062]	0.40 [3.540]	1.50 [13.277]	2.18 [19.295]	4.46 [39.475]	6.70 [59.302]	
	Rolling	0.12 [1.062]	0.40 [3.540]	1.80 [15.932]	2.18 [19.295]	4.46 [39.475]	8.00 [70.808]	
	Yawing	0.21 [1.859]	0.68 [6.019]	2.20 [19.472]	4.18 [36.997]	7.31 [64.701]	13.70 [121.259]	
Clean room rating ^{Note 1}		Class 6 equivalent (FED-STD Class 1000 equivalent) ^{Note 2}						

Note 1: Koganei standard. Dust collection port not available.

2: FED-STD was abolished as of November 2001, and it is designed here for reference purposed.

Linear guide being used

Cylinder bore	Rail width	Manufacturer
φ 8 [0.315], φ 12 [0.472]	5 [0.197]	THK
φ 16 [0.630]	7 [0.276]	
φ 20 [0.787]	9 [0.354]	
φ 25 [0.984]	12 [0.472]	
φ 32 [1.260]	15 [0.591]	
φ 40 [1.575]	20 [0.787]	

Cylinder bore and stroke

Cylinder bore	Standard stroke
8, 12, 16, 20, 25 [0.315, 0.472, 0.630, 0.787, 0.984]	5 ^{Note} , 10, 15 ^{Note} , 20, 25 ^{Note} , 30, 35 ^{Note} , 40, 45 ^{Note} , 50, 55 ^{Note} , 60
32 [1.260]	10, 15 ^{Note} , 20, 25 ^{Note} , 30, 35 ^{Note} , 40, 45 ^{Note} , 50, 55 ^{Note} , 60
40 [1.575]	10 ^{Note} , 15 ^{Note} , 20, 25 ^{Note} , 30, 35 ^{Note} , 40, 45 ^{Note} , 50, 55 ^{Note} , 60

Note: Collar stopper is used in this stroke.

Order Codes (Clean system compatible cylinders)

■ Cylinder with guide

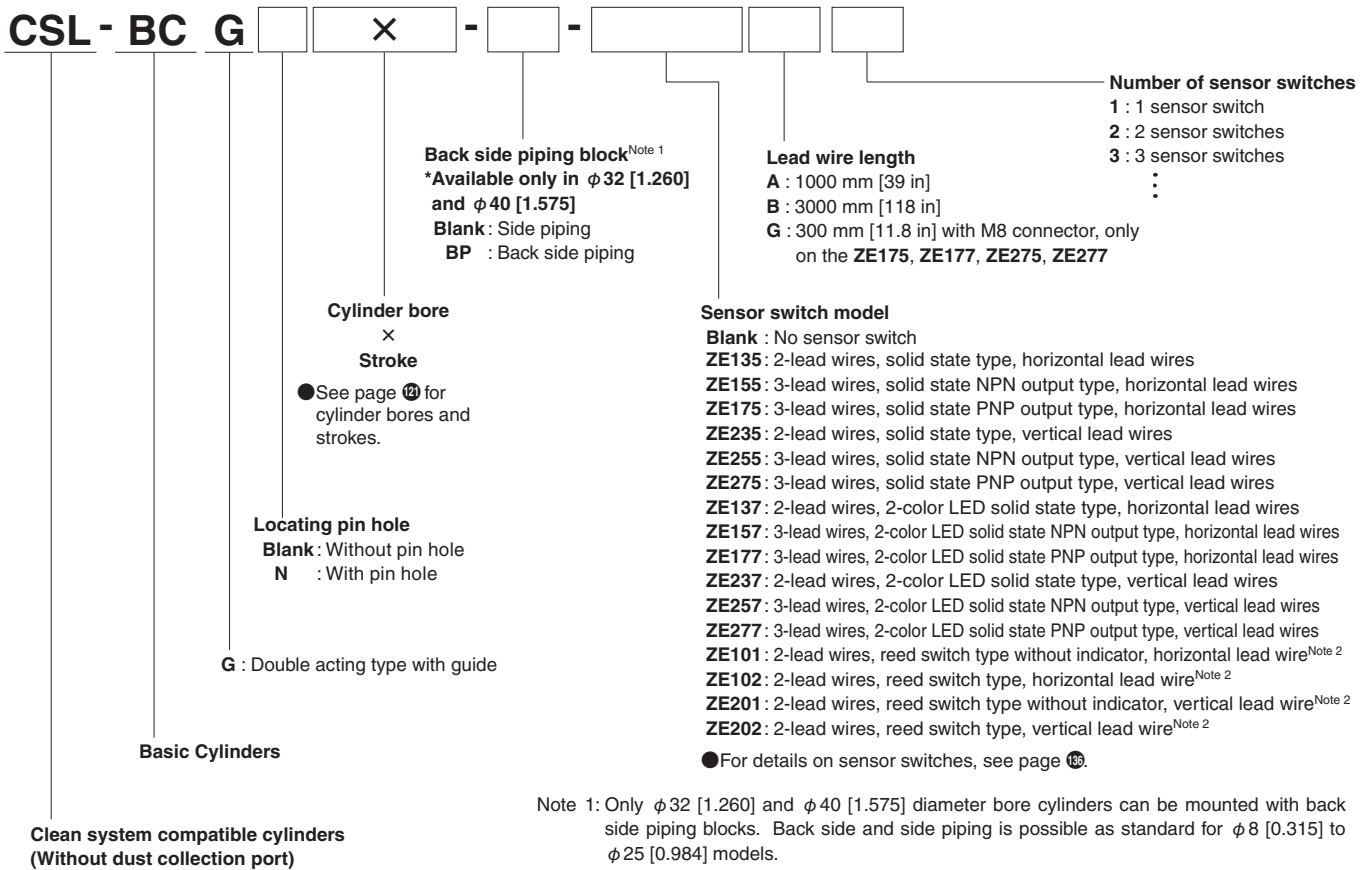

Mass

● Cylinder with guide

g [oz]

Model	Stroke mm [in]											
	5 [0.197]	10 [0.394]	15 [0.591]	20 [0.787]	25 [0.984]	30 [1.181]	35 [1.378]	40 [1.575]	45 [1.772]	50 [1.969]	55 [2.165]	60 [2.362]
CSL-BCG8	56 [1.975]	54 [1.905]	68 [2.399]	66 [2.328]	80 [2.822]	78 [2.751]	92 [3.245]	90 [3.175]	104 [3.7]	102 [3.6]	116 [4.1]	114 [4.0]
CSL-BCG12	82 [2.892]	81 [2.857]	96 [3.386]	95 [3.351]	110 [3.9]	109 [3.8]	124 [4.4]	123 [4.3]	138 [4.9]	137 [4.8]	152 [5.4]	151 [5.3]
CSL-BCG16	133 [4.7]	131 [4.6]	155 [5.5]	153 [5.4]	178 [6.3]	176 [6.2]	200 [7.1]	198 [7.0]	222 [7.8]	220 [7.8]	245 [8.6]	243 [8.6]
CSL-BCG20	207 [7.3]	205 [7.2]	236 [8.3]	234 [8.3]	265 [9.3]	263 [9.3]	294 [10.4]	292 [10.3]	323 [11.4]	321 [11.3]	352 [12.4]	350 [12.3]
CSL-BCG25	321 [11.3]	317 [11.2]	366 [12.9]	362 [12.8]	411 [14.5]	407 [14.4]	456 [16.1]	452 [15.9]	501 [17.7]	497 [17.5]	546 [19.3]	542 [19.1]
CSL-BCG32	—	597 [21.1]	675 [23.8]	669 [23.6]	746 [26.3]	740 [26.1]	818 [28.9]	812 [28.6]	889 [31.4]	883 [31.1]	961 [33.9]	955 [33.7]
CSL-BCG40	—	1031 [36]	1025 [36]	1019 [36]	1122 [40]	1116 [39]	1219 [43]	1213 [43]	1316 [46]	1310 [46]	1413 [50]	1407 [50]

In the case of back side piping specifications, mass is 76 g [2.68 oz] for a $\phi 32$ [1.260] cylinder bore and 108 g [3.8 oz] for a $\phi 40$ [1.575] cylinder bore.

● Additional mass of sensor switches

ZE□□□A, ZE□□□G: 15 g [0.53 oz] ZE□□□B: 35 g [1.23 oz]

Inner construction

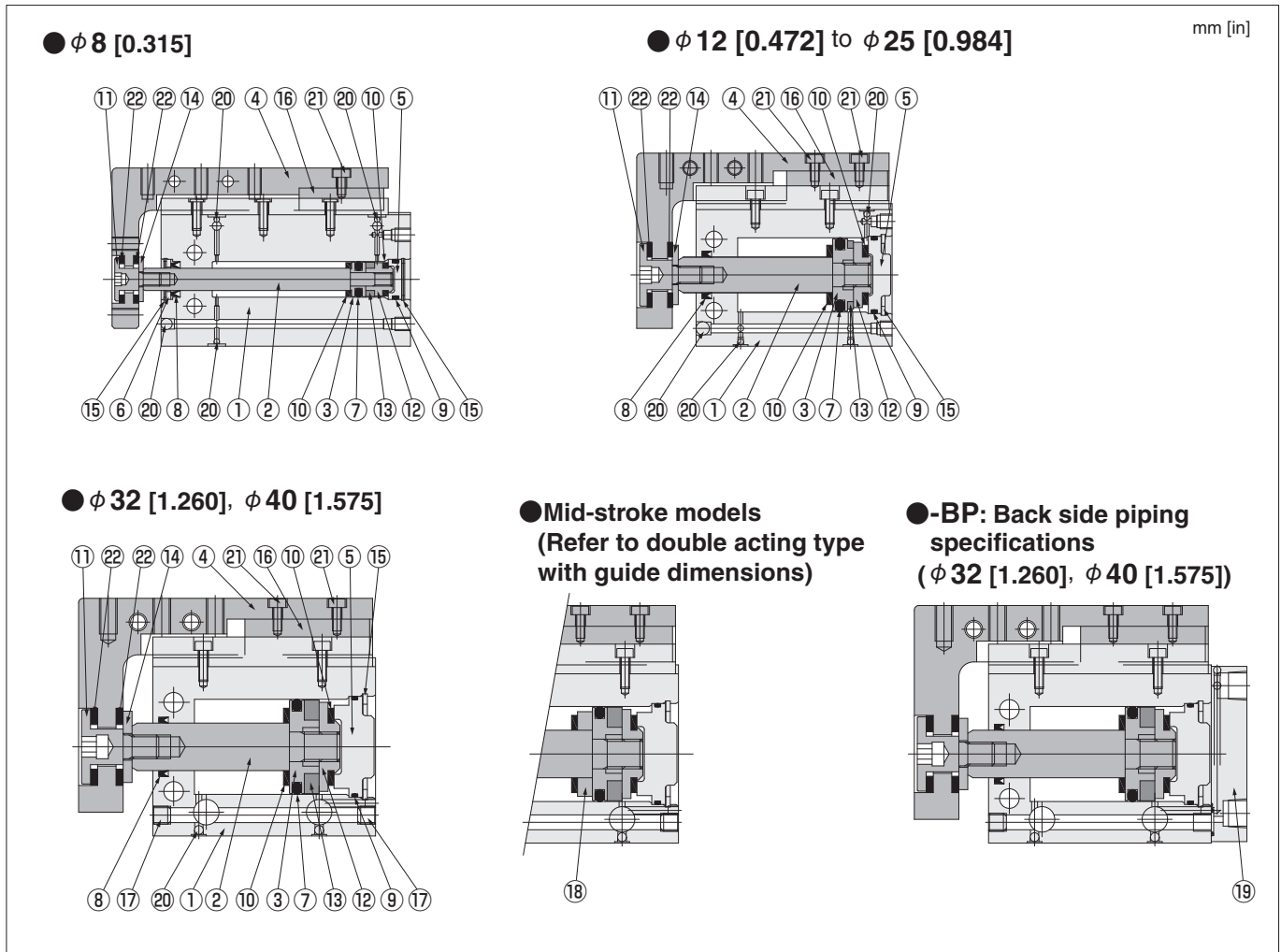

Major parts and materials (clean room specification)

No.	Name	$\phi 8$ [0.315]	$\phi 12$ [0.472]	$\phi 16$ [0.630]	$\phi 20$ [0.787]	$\phi 25$ [0.984]	$\phi 32$ [1.260]	$\phi 40$ [1.575]
①	Cylinder body	Aluminum alloy (special anti-abrasion treated)						
②	Piston rod	Stainless steel						
③	Piston	Stainless steel	Aluminum alloy (anodized)					
④	Table	Aluminum alloy (anodized)						
⑤	Head cover	Aluminum alloy (anodized)						
⑥	Seal holder	Aluminum alloy (Anodized)	—	—	—	—	—	—
⑦	★ Piston seal	Synthetic rubber (NBR)						
⑧	★ Rod seal	Synthetic rubber (NBR)						
⑨	★ O-ring	Synthetic rubber (NBR)						
⑩	Bumper	Synthetic rubber (NBR)						
⑪	End bolt	Stainless steel						
⑫	Support	Aluminum alloy (anodized)						
⑬	Magnet	Neodymium magnet					Plastic magnet	
⑭	Bolt retainer	Stainless steel						
⑮	★ Retaining ring	Stainless steel	Steel (electroless nickel plated)					
⑯	Linear guide	Stainless steel						
⑰	Plug	—	—	—	—	—	Stainless steel	
⑱	Collar	Aluminum alloy (anodized)						
⑲	★ Back side piping block	—	—	—	—	—	Aluminum alloy (anodized)	
⑳	Steel ball	Stainless steel						
㉑	Bolt	Stainless steel						
㉒	Bumper	Urethane rubber						

Items indicated by a ★ are available as additional parts or in packing sets. For order codes, see page 123 and 125.

Double acting clean system compatible cylinder with guide dimensions

unit: mm

● CSL-BCG□8 (clean room specification)

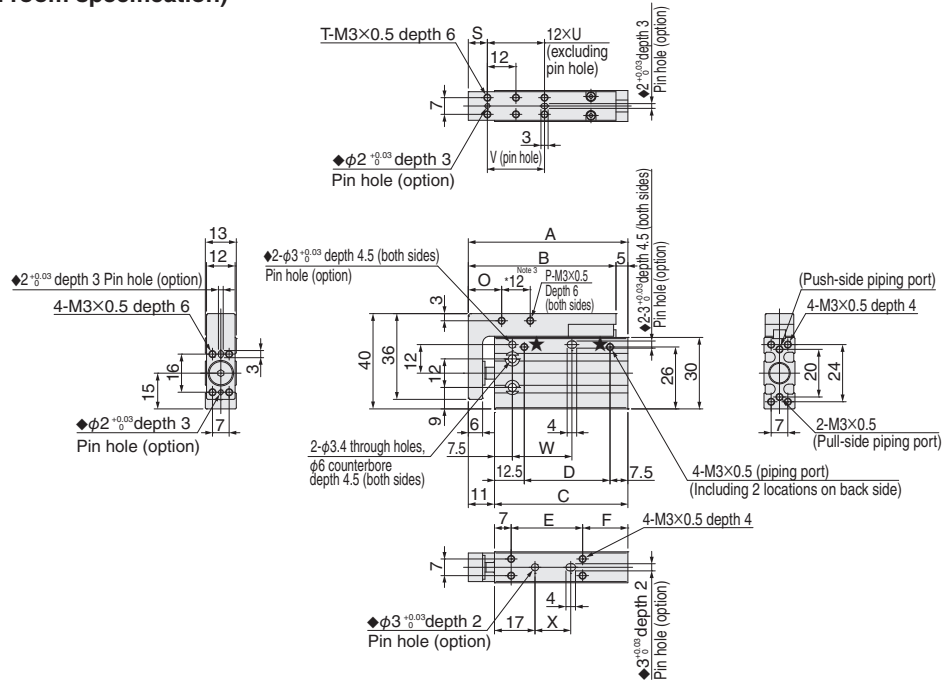

Stroke	A	B	C	D	E	F	O	P	S	T	U	V	W	X
5, 10	47	42	36	16	15	14	10	2	5	4	-	12	15	10
15, 20	57	52	46	26	20	19	14	4	8	4	-	12	15	15
25, 30	67	62	56	36	30	19	14	4	8	6	2	24	25	15
35, 40	77	72	66	46	40	19	14	4	8	8	3	24	25	25
45, 50	87	82	76	56	50	19	14	4	8	10	4	36	35	35
55, 60	97	92	86	66	60	19	14	4	8	12	5	36	35	45

- Note 1: This product cannot use reed switch type sensor switches.
 Note 2: 5, 15, 25, 35, 45, and 55 stroke has a collar stopper.
 Note 3: Dimensions indicated by * are for strokes longer than 15.
 Note 4: All piping ports are assembled with plugs, except those indicated by ★.
 Note 5: Apply grease to o-rings when changing plug assemblies.
 Note 6: Pin holes indicated by ◆ are provided only when selected as an option (N).

● CSL-BCG□12 (clean room specification)

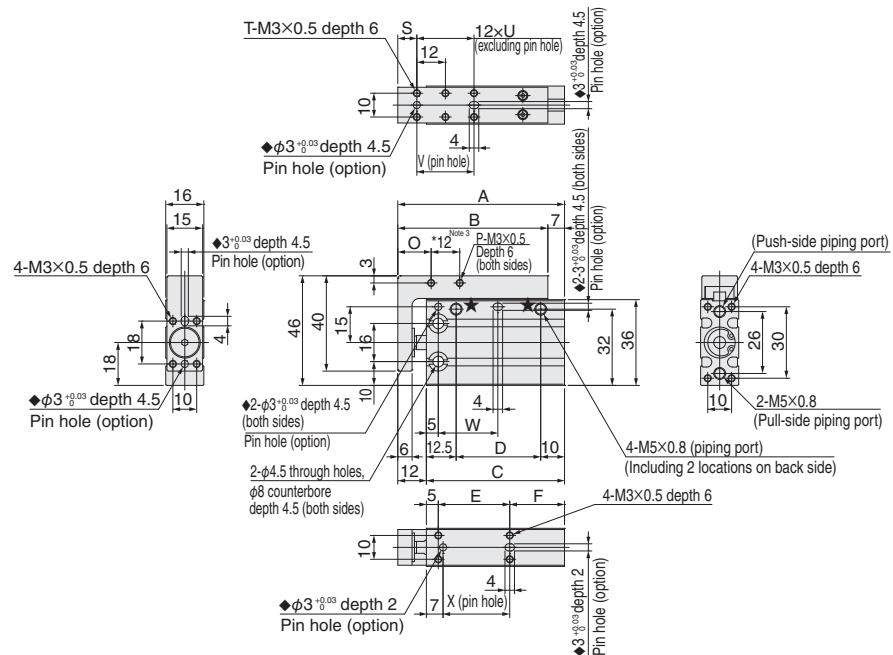

Stroke	A	B	C	D	E	F	O	P	S	T	U	V	W	X
5, 10	50	43	38	15.5	15	18	10	2	5	4	-	12	15	13
15, 20	60	53	48	25.5	20	23	14	4	8	4	-	12	15	18
25, 30	70	63	58	35.5	30	23	14	4	8	6	2	24	25	28
35, 40	80	73	68	45.5	40	23	14	4	8	8	3	24	25	38
45, 50	90	83	78	55.5	50	23	14	4	8	10	4	36	35	48
55, 60	100	93	88	65.5	60	23	14	4	8	12	5	36	35	58

- Note 1: This product cannot use reed switch type sensor switches.
 Note 2: 5, 15, 25, 35, 45, and 55 stroke has a collar stopper.
 Note 3: Dimensions indicated by * are for strokes longer than 15.
 Note 4: All piping ports are assembled with plugs, except those indicated by ★.
 Note 5: Apply grease to o-rings when changing plug assemblies.
 Note 6: Pin holes indicated by ◆ are provided only when selected as an option (N).

● CSL-BCG □8 (clean room specification)

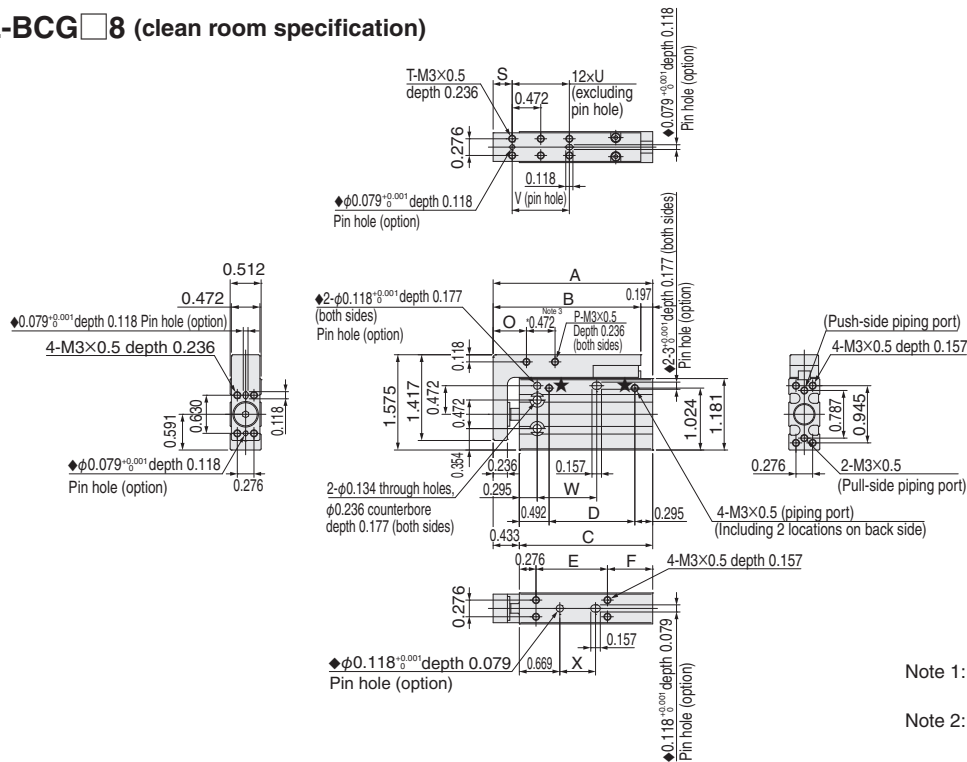

Stroke	A	B	C	D	E	F	O	P	S	T	U	V	W	X
5 mm, 10 mm [0.197, 0.394]	1.850	1.654	1.417	0.630	0.591	0.551	0.394	0.079	0.197	0.157	-	0.472	0.591	0.394
15 mm, 20 mm [0.591, 0.787]	2.244	2.047	1.811	1.024	0.787	0.748	0.551	0.157	0.315	0.157	-	0.472	0.591	0.591
25 mm, 30 mm [0.984, 1.181]	2.638	2.441	2.205	1.417	1.181	0.748	0.551	0.157	0.315	0.236	0.079	0.945	0.984	0.591
35 mm, 40 mm [1.378, 1.575]	3.031	2.835	2.598	1.811	1.575	0.748	0.551	0.157	0.315	0.315	0.118	0.945	0.984	0.984
45 mm, 50 mm [1.772, 1.969]	3.425	3.228	2.992	2.205	1.969	0.748	0.551	0.157	0.315	0.394	0.157	1.417	1.378	1.378
55 mm, 60 mm [2.165, 2.362]	3.819	3.622	3.386	2.598	2.362	0.748	0.551	0.157	0.315	0.472	0.197	1.417	1.378	1.772

- Note 1: This product cannot use reed switch type sensor switches.
- Note 2: 0.197, 0.591, 0.984, 1.378, 1.772, and 2.165 stroke has a collar stopper.
- Note 3: Dimensions indicated by * are for strokes longer than 0.591.
- Note 4: All piping ports are assembled with plugs, except those indicated by ★.
- Note 5: Apply grease to o-rings when changing plug assemblies.
- Note 6: Pin holes indicated by ◆ are provided only when selected as an option (N).

● CSL-BCG □12 (clean room specification)

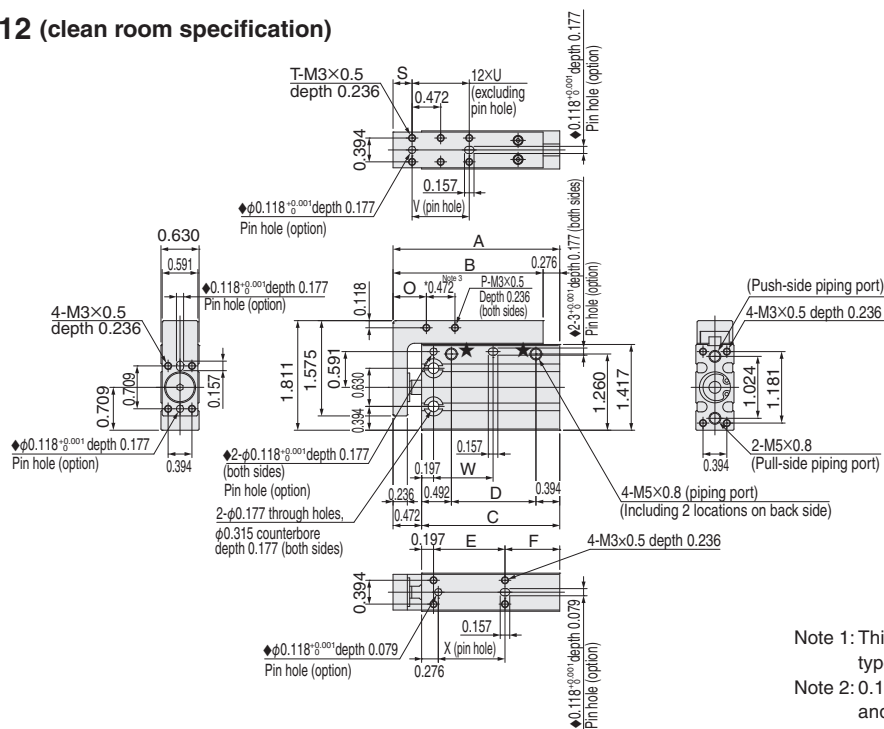

Stroke	A	B	C	D	E	F	O	P	S	T	U	V	W	X
5 mm, 10 mm [0.197, 0.394]	1.969	1.693	1.496	0.610	0.591	0.709	0.394	0.079	0.197	0.157	-	0.472	0.591	0.512
15 mm, 20 mm [0.591, 0.787]	2.362	2.087	1.890	1.004	0.787	0.906	0.551	0.157	0.315	0.157	-	0.472	0.591	0.709
25 mm, 30 mm [0.984, 1.181]	2.756	2.480	2.283	1.398	1.181	0.906	0.551	0.157	0.315	0.236	0.079	0.945	0.984	1.102
35 mm, 40 mm [1.378, 1.575]	3.150	2.874	2.677	1.791	1.575	0.906	0.551	0.157	0.315	0.315	0.118	0.945	0.984	1.496
45 mm, 50 mm [1.772, 1.969]	3.543	3.268	3.071	2.185	1.969	0.906	0.551	0.157	0.315	0.394	0.157	1.417	1.378	1.890
55 mm, 60 mm [2.165, 2.362]	3.937	3.661	3.465	2.579	2.362	0.906	0.551	0.157	0.315	0.472	0.197	1.417	1.378	2.283

- Note 1: This product cannot use reed switch type sensor switches.
- Note 2: 0.197, 0.591, 0.984, 1.378, 1.772, and 2.165 stroke has a collar stopper.
- Note 3: Dimensions indicated by * are for strokes longer than 0.591.
- Note 4: All piping ports are assembled with plugs, except those indicated by ★.
- Note 5: Apply grease to o-rings when changing plug assemblies.
- Note 6: Pin holes indicated by ◆ are provided only when selected as an option (N).

● CSL-BCG $\square 16$ (clean room specification)

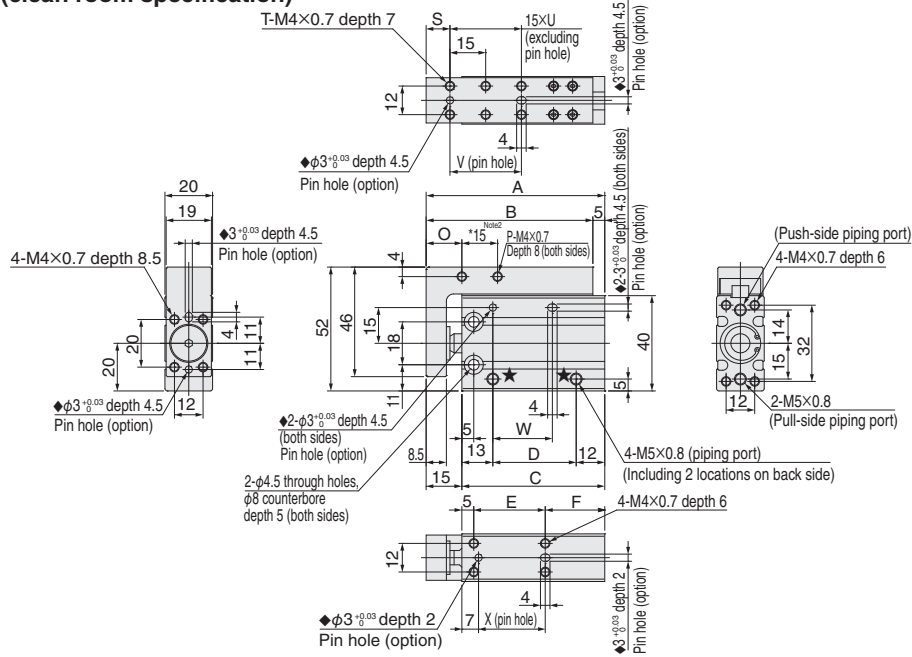

Stroke	A	B	C	D	E	F	O	P	S	T	U	V	W	X
5, 10	55	50	40	15	15	20	12	2	5	4	-	15	15	13
15, 20	65	60	50	25	20	25	15	4	10	4	-	15	15	18
25, 30	75	70	60	35	30	25	15	4	10	6	2	30	25	28
35, 40	85	80	70	45	40	25	15	4	10	6	2	30	25	38
45, 50	95	90	80	55	50	25	15	4	10	8	3	45	35	48
55, 60	105	100	90	65	60	25	15	4	10	10	4	45	35	58

Note 1: 5, 15, 25, 35, 45, and 55 stroke support collar stopper.
 Note 2: Dimensions indicated by * are for strokes longer than 15.
 Note 3: All piping ports are assembled with plugs, except those indicated by ★.
 Note 4: Apply grease to o-rings when changing plug assemblies.
 Note 5: Pin holes indicated by ◆ are provided only when selected as an option (N).

● CSL-BCG $\square 20$ (clean room specification)

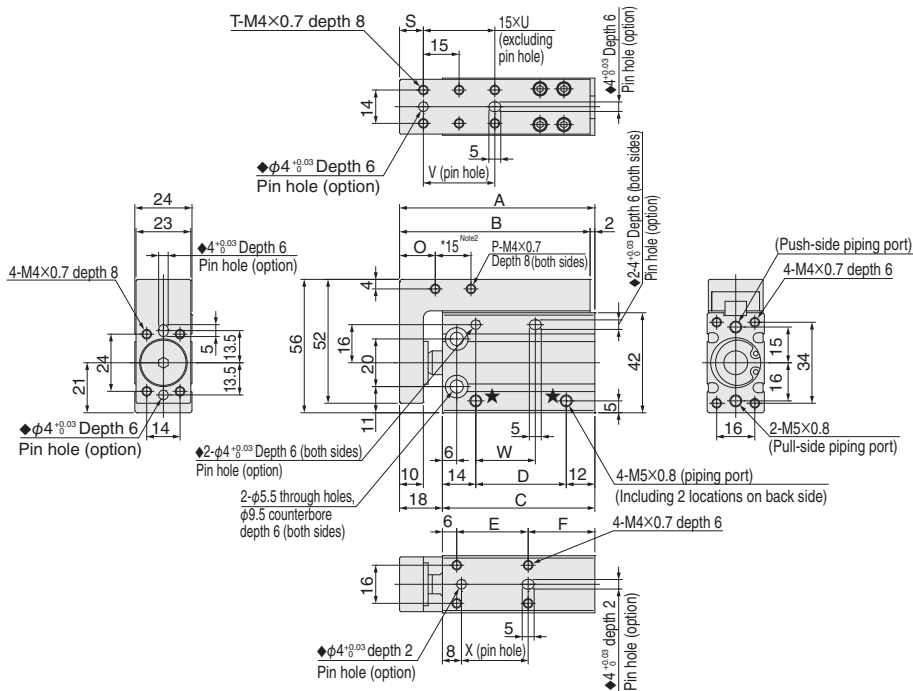

Stroke	A	B	C	D	E	F	O	P	S	T	U	V	W	X
5, 10	62	60	44	18	15	23	12	2	5	4	-	15	15	13
15, 20	72	70	54	28	20	28	15	4	10	4	-	15	15	18
25, 30	82	80	64	38	30	28	15	4	10	6	2	30	25	28
35, 40	92	90	74	48	40	28	15	4	10	6	2	30	25	38
45, 50	102	100	84	58	50	28	15	4	10	8	3	45	35	48
55, 60	112	110	94	68	60	28	15	4	10	10	4	45	35	58

Note 1: 5, 15, 25, 35, 45, and 55 stroke support collar stopper.
 Note 2: Dimensions indicated by * are for strokes longer than 15.
 Note 3: All piping ports are assembled with plugs, except those indicated by ★.
 Note 4: Apply grease to o-rings when changing plug assemblies.
 Note 5: Pin holes indicated by ◆ are provided only when selected as an option (N).

● CSL-BCG □ 16 (clean room specification)

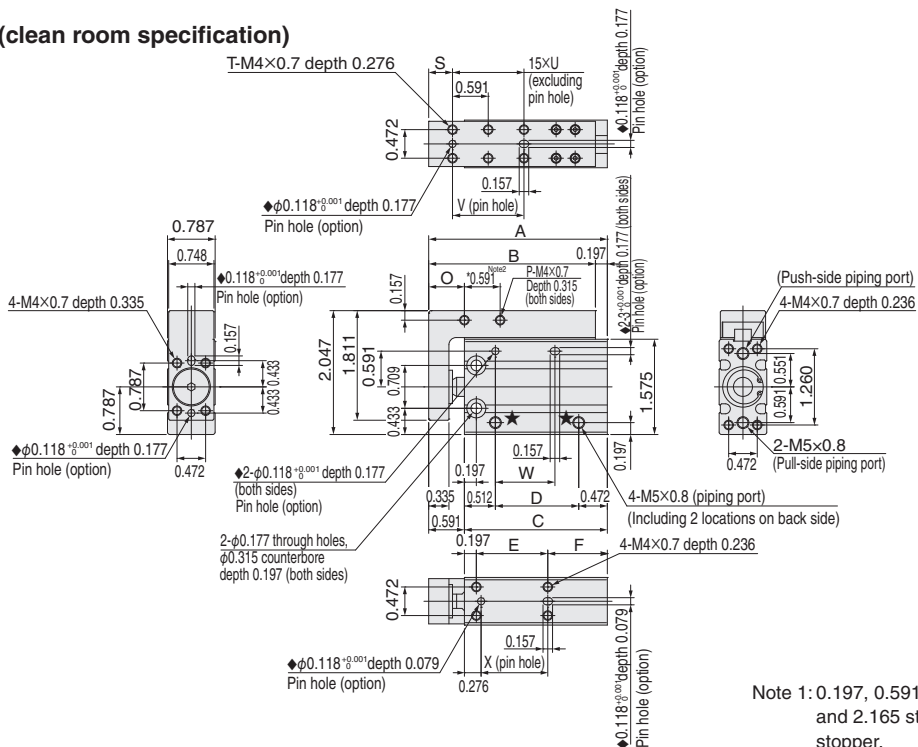

- Note 1: 0.197, 0.591, 0.984, 1.378, 1.772, and 2.165 stroke support collar stopper.
- Note 2: Dimensions indicated by * are for strokes longer than 0.591.
- Note 3: All piping ports are assembled with plugs, except those indicated by ★.
- Note 4: Apply grease to o-rings when changing plug assemblies.
- Note 5: Pin holes indicated by ◆ are provided only when selected as an option (N).

Stroke	A	B	C	D	E	F	O	P	S	T	U	V	W	X
5 mm, 10 mm [0.197, 0.394]	2.165	1.969	1.575	0.591	0.591	0.787	0.472	0.079	0.197	0.157	-	0.591	0.591	0.512
15 mm, 20 mm [0.591, 0.787]	2.559	2.362	1.969	0.984	0.787	0.984	0.591	0.157	0.394	0.157	-	0.591	0.591	0.709
25 mm, 30 mm [0.984, 1.181]	2.953	2.756	2.362	1.378	1.181	0.984	0.591	0.157	0.394	0.236	0.079	1.181	0.984	1.102
35 mm, 40 mm [1.378, 1.575]	3.346	3.150	2.756	1.772	1.575	0.984	0.591	0.157	0.394	0.236	0.079	1.181	0.984	1.496
45 mm, 50 mm [1.772, 1.969]	3.740	3.543	3.150	2.165	1.969	0.984	0.591	0.157	0.394	0.315	0.118	1.772	1.378	1.890
55 mm, 60 mm [2.165, 2.362]	4.134	3.937	3.543	2.559	2.362	0.984	0.591	0.157	0.394	0.394	0.157	1.772	1.378	2.283

● CSL-BCG □ 20 (clean room specification)

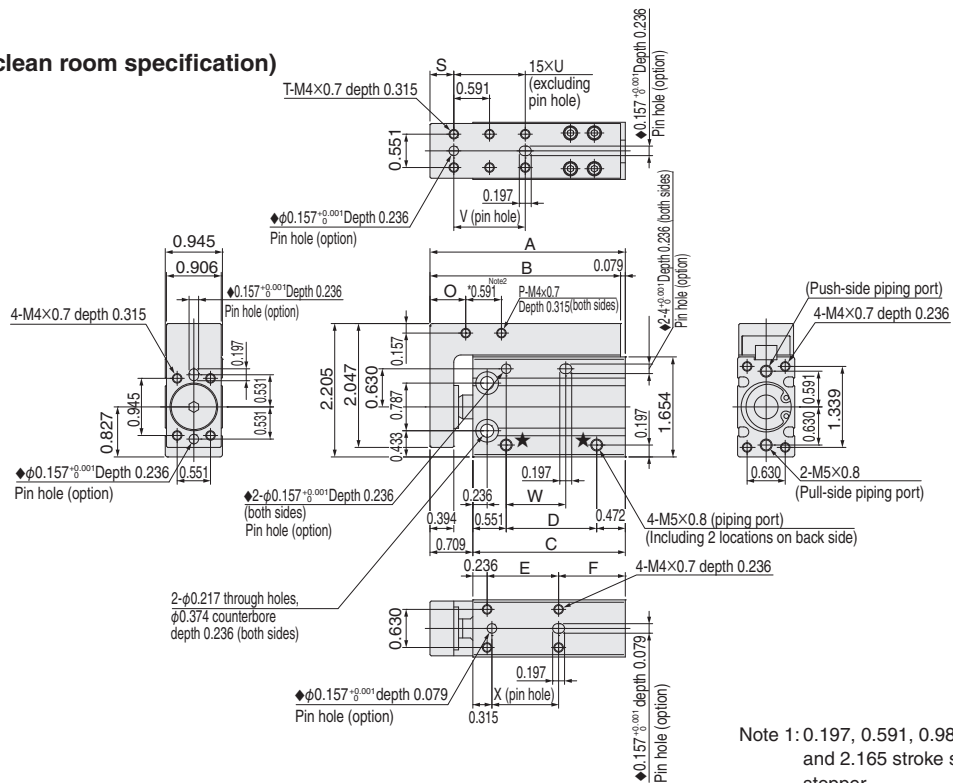

- Note 1: 0.197, 0.591, 0.984, 1.378, 1.772, and 2.165 stroke support collar stopper.
- Note 2: Dimensions indicated by * are for strokes longer than 0.591.
- Note 3: All piping ports are assembled with plugs, except those indicated by ★.
- Note 4: Apply grease to o-rings when changing plug assemblies.
- Note 5: Pin holes indicated by ◆ are provided only when selected as an option (N).

Stroke	A	B	C	D	E	F	O	P	S	T	U	V	W	X
5 mm, 10 mm [0.197, 0.394]	2.441	2.362	1.732	0.709	0.591	0.906	0.472	0.079	0.197	0.157	-	0.591	0.591	0.512
15 mm, 20 mm [0.591, 0.787]	2.835	2.756	2.126	1.102	0.787	1.102	0.591	0.157	0.394	0.157	-	0.591	0.591	0.709
25 mm, 30 mm [0.984, 1.181]	3.228	3.150	2.520	1.496	1.181	1.102	0.591	0.157	0.394	0.236	0.079	1.181	0.984	1.102
35 mm, 40 mm [1.378, 1.575]	3.622	3.543	2.913	1.890	1.575	1.102	0.591	0.157	0.394	0.236	0.079	1.181	0.984	1.496
45 mm, 50 mm [1.772, 1.969]	4.016	3.937	3.307	2.283	1.969	1.102	0.591	0.157	0.394	0.315	0.118	1.772	1.378	1.890
55 mm, 60 mm [2.165, 2.362]	4.409	4.331	3.701	2.677	2.362	1.102	0.591	0.157	0.394	0.394	0.157	1.772	1.378	2.283

● CSL-BCG □25 (clean room specification)

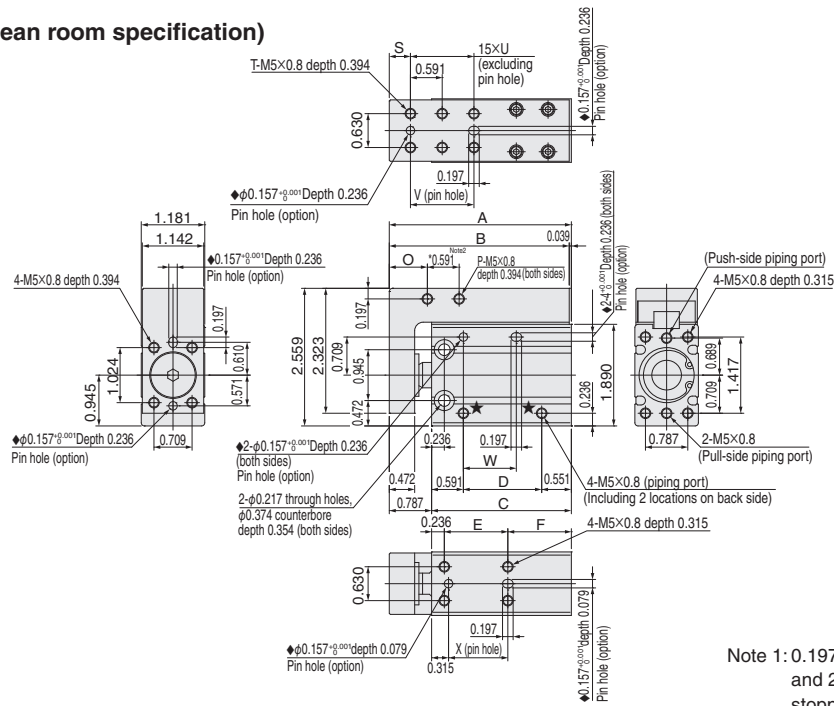

Note 1: 0.197, 0.591, 0.984, 1.378, 1.772, and 2.165 stroke support collar stopper.

Note 2: Dimensions indicated by * are for strokes longer than 0.591.

Note 3: All piping ports are assembled with plugs, except those indicated by ★.

Note 4: Apply grease to o-rings when changing plug assemblies.

Note 5: Pin holes indicated by ◆ are provided only when selected as an option (N).

Stroke	A	B	C	D	E	F	O	P	S	T	U	V	W	X
5 mm, 10 mm [0.197, 0.394]	2.598	2.559	1.811	0.669	0.591	0.984	0.472	0.079	0.197	0.157	-	0.591	0.591	0.591
15 mm, 20 mm [0.591, 0.787]	2.992	2.953	2.205	1.063	0.787	1.181	0.709	0.157	0.394	0.157	-	0.591	0.591	0.709
25 mm, 30 mm [0.984, 1.181]	3.386	3.346	2.598	1.457	1.181	1.181	0.709	0.157	0.394	0.236	0.079	1.181	0.984	1.102
35 mm, 40 mm [1.378, 1.575]	3.780	3.740	2.992	1.850	1.575	1.181	0.709	0.157	0.394	0.236	0.079	1.181	0.984	1.496
45 mm, 50 mm [1.772, 1.969]	4.173	4.134	3.386	2.244	1.969	1.181	0.709	0.157	0.394	0.315	0.118	1.772	1.378	1.890
55 mm, 60 mm [2.165, 2.362]	4.567	4.528	3.780	2.638	2.362	1.181	0.709	0.157	0.394	0.394	0.157	1.772	1.378	2.283

● CSL-BCG □32 (clean room specification)

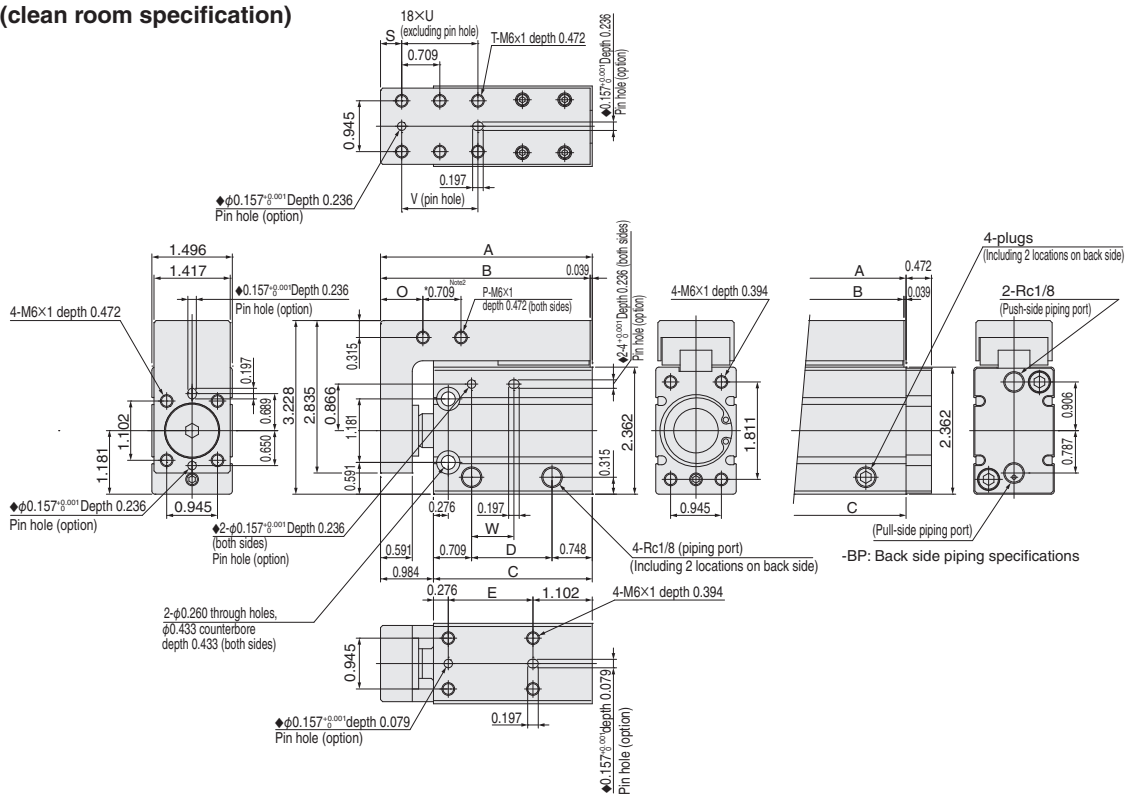

Note 1: 0.591, 0.984, 1.378, 1.772, and 2.165 stroke support collar stopper.

Note 2: Dimensions indicated by * are for strokes longer than 0.984.

Note 3: Plugs are included for specifications other than back side piping specifications. Assemble using sealant, etc.

Note 4: Pin holes indicated by ◆ are provided only when selected as an option (N).

Stroke	A	B	C	D	E	O	P	S	T	U	V	W
10 mm [0.394]	3.150	3.110	2.165	0.709	0.787	0.630	0.079	0.236	0.157	-	0.709	0.787
15 mm, 20 mm [0.591, 0.787]	3.543	3.504	2.559	1.102	1.181	0.787	0.079	0.394	0.157	-	0.709	0.787
25 mm, 30 mm [0.984, 1.181]	3.937	3.898	2.953	1.496	1.575	0.787	0.157	0.394	0.236	0.079	1.417	1.181
35 mm, 40 mm [1.378, 1.575]	4.331	4.291	3.346	1.890	1.969	0.787	0.157	0.394	0.236	0.079	1.417	1.181
45 mm, 50 mm [1.772, 1.969]	4.724	4.685	3.740	2.283	2.362	0.787	0.157	0.394	0.315	0.118	2.126	1.575
55 mm, 60 mm [2.165, 2.362]	5.118	5.079	4.134	2.677	2.756	0.787	0.157	0.394	0.315	0.118	2.126	1.575

●CSL-BCG□40 (clean room specification)

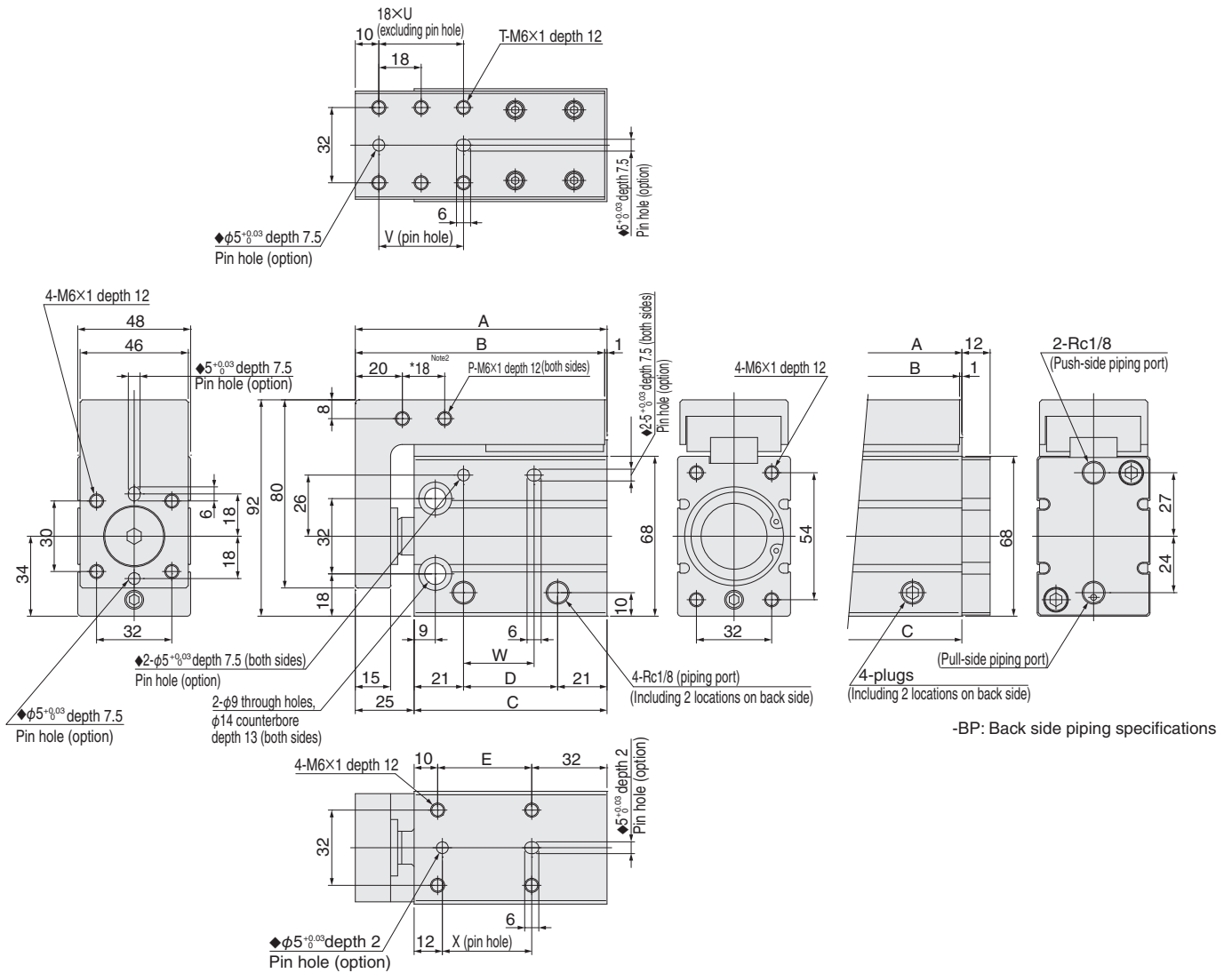

-BP: Back side piping specifications

Stroke	A	B	C	D	E	P	T	U	V	W	X
10, 15, 20	97	96	72	30	30	2	4	-	18	25	28
25, 30	107	106	82	40	40	4	6	2	36	30	38
35, 40	117	116	92	50	50	4	6	2	36	30	48
45, 50	127	126	102	60	60	4	8	3	54	40	58
55, 60	137	136	112	70	70	4	8	3	54	40	68

- Note 1: 10, 15, 25, 35, 45, and 55 stroke support collar stopper.
- Note 2: Dimensions indicated by * are for strokes longer than 25.
- Note 3: Plugs are included for specifications other than back side piping specifications. Assemble using sealant, etc.
- Note 4: Pin holes indicated by ◆ are provided only when selected as an option (N).

● CSL-BCG □ 40 (clean room specification)

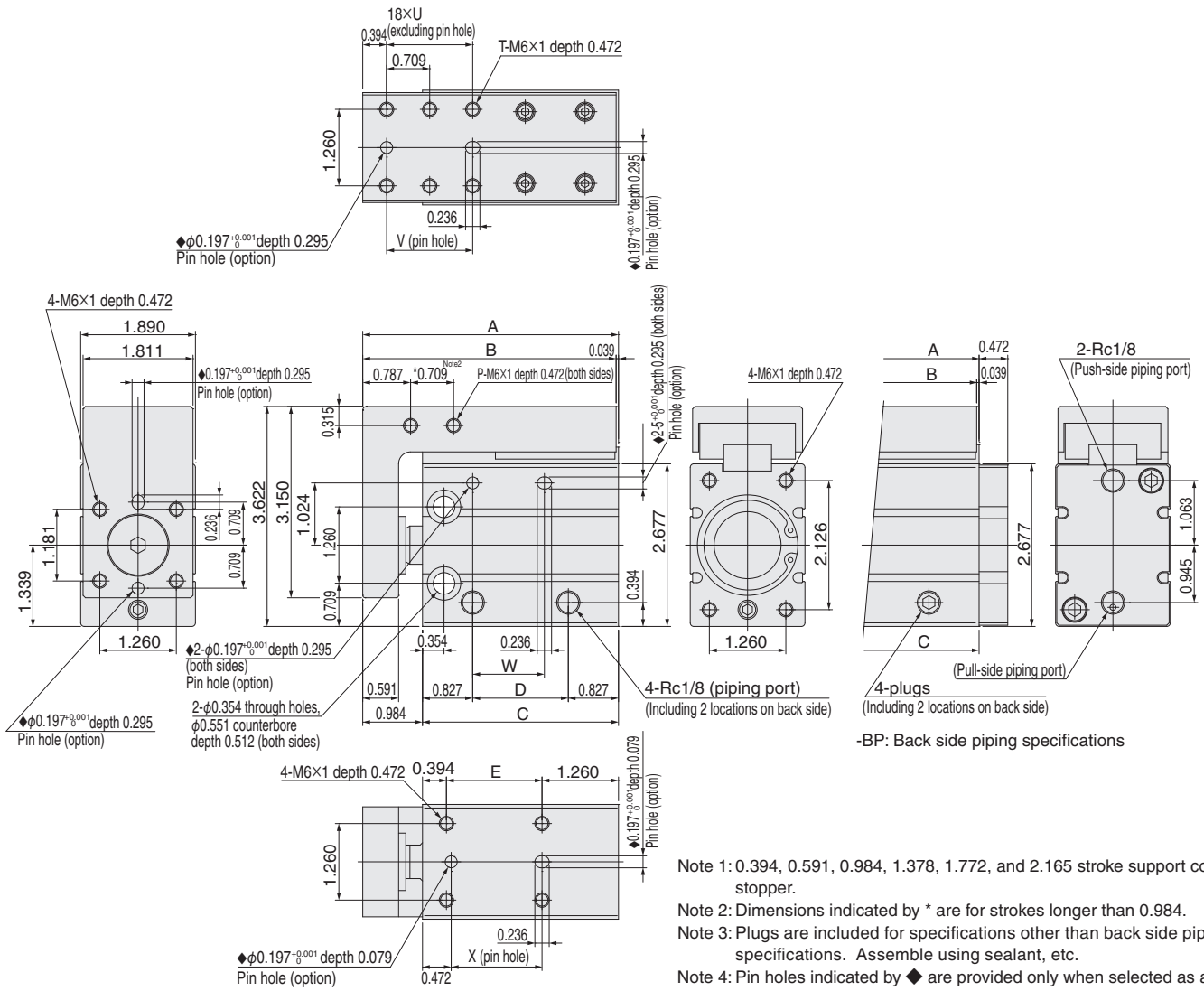

Stroke	A	B	C	D	E	P	T	U	V	W	X
10 mm, 15 mm, 20 mm [0.394, 0.591, 0.787]	3.819	3.780	2.835	1.181	1.181	0.079	0.157	-	0.709	0.984	1.102
25 mm, 30 mm [0.984, 1.181]	4.213	4.173	3.228	1.575	1.575	0.157	0.236	0.079	1.417	1.181	1.496
35 mm, 40 mm [1.378, 1.575]	4.606	4.567	3.622	1.969	1.969	0.157	0.236	0.079	1.417	1.181	1.890
45 mm, 50 mm [1.772, 1.969]	5.000	4.961	4.016	2.362	2.362	0.157	0.315	0.118	2.126	1.575	2.283
55 mm, 60 mm [2.165, 2.362]	5.394	5.354	4.409	2.756	2.756	0.157	0.315	0.118	2.126	1.575	2.677

Bracket

Order codes for brackets only mm [in]

BCZ-BK

Cylinder bore

10:For ϕ 10 [0.394]	40:For ϕ 40 [1.575]
12:For ϕ 12 [0.472]	50:For ϕ 50 [1.969]
16:For ϕ 16 [0.630]	63:For ϕ 63 [2.480]
20:For ϕ 20 [0.787]	80:For ϕ 80 [3.150]
25:For ϕ 25 [0.984]	100:For ϕ 100 [3.9]
32:For ϕ 32 [1.260]	125:For ϕ 125 [4.9]

Note: Cannot be mounted on cylinders with guides (BCG).

Bracket dimensions mm [in]

● ϕ 10 [0.394] to ϕ 32 [1.260]

● ϕ 40 [1.575] to ϕ 80 [3.150]

● ϕ 100 [3.9] to ϕ 125 [4.9]

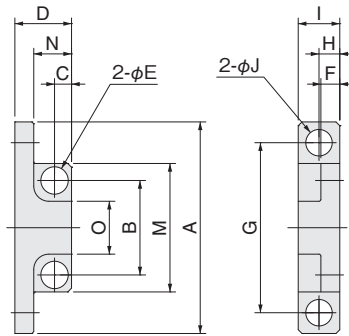
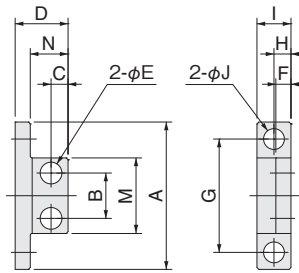
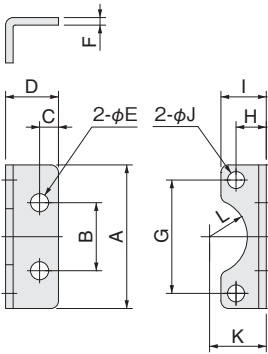

● Mounting bolt (2 pieces)

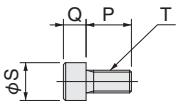

Material: Stainless steel (only M16 is steel)

Bore	Symbol	A	B	C	D	E	F	G	H	I	J	K	L	M	N	O	P	Q	S	T	Materials	Mass [g/oz]
10 [0.394]		22 [0.866]	16 [0.630]	3 [0.118]	10 [0.394]	3.8 [0.150]	1 [0.039]	16 [0.630]	7 [0.276]	9.3 [0.366]	3.4 [0.134]	8 [0.315]	R5 [0.197]	-	-	-	5 [0.197]	3 [0.118]	4.5 [0.177]	M3 × 0.5	Stainless steel	4 [0.141]
12 [0.472]		26 [1.024]	14 [0.551]	4 [0.157]	13 [0.512]	4.8 [0.189]	1 [0.039]	19 [0.748]	8 [0.315]	11 [0.433]	4.5 [0.177]	8 [0.315]	R5 [0.197]	-	-	-	4 [0.157]	4 [0.157]	5.5 [0.217]	M4 × 0.7	Stainless steel	6 [0.212]
16 [0.630]		28 [1.102]	14 [0.551]	4 [0.157]	13 [0.512]	4.8 [0.189]	1.5 [0.059]	22 [0.866]	7 [0.276]	10 [0.394]	3.5 [0.138]	11 [0.433]	R7 [0.276]	-	-	-	5 [0.197]	3 [0.118]	5.5 [0.217]	M3 × 0.5	Stainless steel	7 [0.247]
20 [0.787]		34 [1.339]	14 [0.551]	4 [0.157]	13 [0.512]	4.8 [0.189]	2 [0.079]	26 [1.024]	8 [0.315]	12 [0.472]	4.5 [0.177]	13 [0.512]	R8 [0.315]	-	-	-	8 [0.315]	4 [0.157]	7 [0.276]	M4 × 0.7	Stainless steel	12 [0.423]
25 [0.984]		38 [1.496]	18 [0.709]	5 [0.197]	14 [0.551]	4.8 [0.189]	2 [0.079]	30 [1.181]	8 [0.315]	12 [0.472]	4.5 [0.177]	15 [0.591]	R10 [0.394]	-	-	-	8 [0.315]	4 [0.157]	7 [0.276]	M4 × 0.7	Stainless steel	14 [0.494]
32 [1.260]		48 [1.890]	22 [0.866]	6 [0.236]	18 [0.709]	5.8 [0.228]	2 [0.079]	38 [1.496]	8 [0.315]	13 [0.512]	5.5 [0.217]	19 [0.748]	R12 [0.472]	-	-	-	8 [0.315]	5 [0.197]	8.5 [0.335]	M5 × 0.8	Stainless steel	24 [0.847]
40 [1.575]		52 [2.047]	18 [0.709]	6 [0.236]	20 [0.787]	6.8 [0.268]	5 [0.197]	40 [1.575]	7 [0.276]	13 [0.512]	6.5 [0.256]	-	-	28 [1.102]	14 [0.551]	-	12 [0.472]	6 [0.236]	10 [0.394]	M6 × 1	Aluminum alloy	25 [0.882]
50 [1.969]		66 [2.598]	24 [0.945]	7 [0.276]	24 [0.945]	9.5 [0.374]	5 [0.197]	52 [2.047]	8 [0.276]	15 [0.591]	9 [0.354]	-	-	37 [1.457]	18 [0.709]	-	12 [0.472]	8 [0.315]	13 [0.512]	M8 × 1.25	Aluminum alloy	45 [1.587]
63 [2.480]		78 [3.071]	24 [0.945]	9 [0.354]	28 [1.102]	11.5 [0.453]	8 [0.315]	60 [2.362]	9 [0.354]	18 [0.709]	11 [0.433]	-	-	40 [1.575]	20 [0.787]	-	16 [0.630]	10 [0.394]	16 [0.630]	M10 × 1.5	Aluminum alloy	80 [2.822]
80 [3.150]		90 [3.543]	30 [1.181]	10 [0.394]	36 [1.417]	14.5 [0.571]	8 [0.315]	70 [2.756]	10 [0.394]	20 [0.787]	14 [0.551]	-	-	48 [1.890]	28 [1.102]	-	20 [0.787]	12 [0.472]	18 [0.709]	M12 × 1.75	Aluminum alloy	128 [4.5]
100 [3.9]		112 [4.4]	50 [1.969]	9 [0.354]	30 [1.181]	14.5 [0.571]	10 [0.394]	90 [3.543]	11 [0.433]	22 [0.866]	14 [0.551]	-	-	68 [2.677]	20 [0.787]	28 [1.102]	20 [0.787]	12 [0.472]	18 [0.709]	M12 × 1.75	Aluminum alloy	167 [5.9]
125 [4.9]		140 [5.5]	58 [2.283]	14 [0.551]	42 [1.654]	18.5 [0.728]	14 [0.551]	110 [4.331]	15 [0.591]	30 [1.181]	18 [0.709]	-	-	82 [3.228]	30 [1.181]	30 [1.181]	35 [1.378]	16 [0.630]	24 [0.945]	M16 × 2	Aluminum alloy	410 [14.5]

Note: Mass includes mass of 2 supplied bolts

Piston rod end shape pattern diagrams

There are seven patternized piston rod end shapes. A non-standard end shaped cylinder can be order made by simply filling in the items on the order that has the required shape drawn on it. This applies to all types of basic cylinders. Contact Koganei for order forms with pattern shaped drawn on them.

Order code example

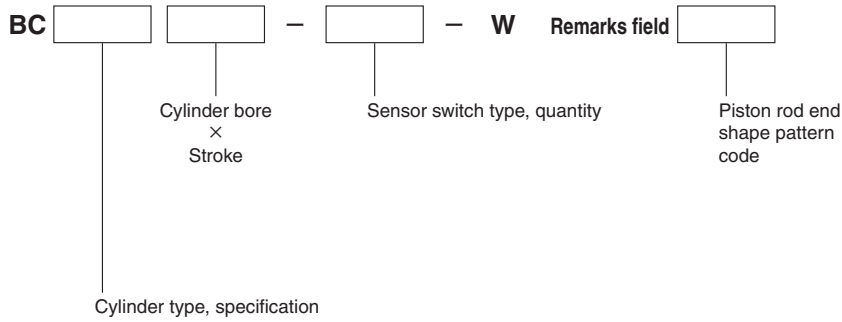

Note: For clean room specifications, CS- or CSL- is appended before BC. For details, see the pages for the corresponding order codes.

Piston rod end shape pattern diagrams (7 types)

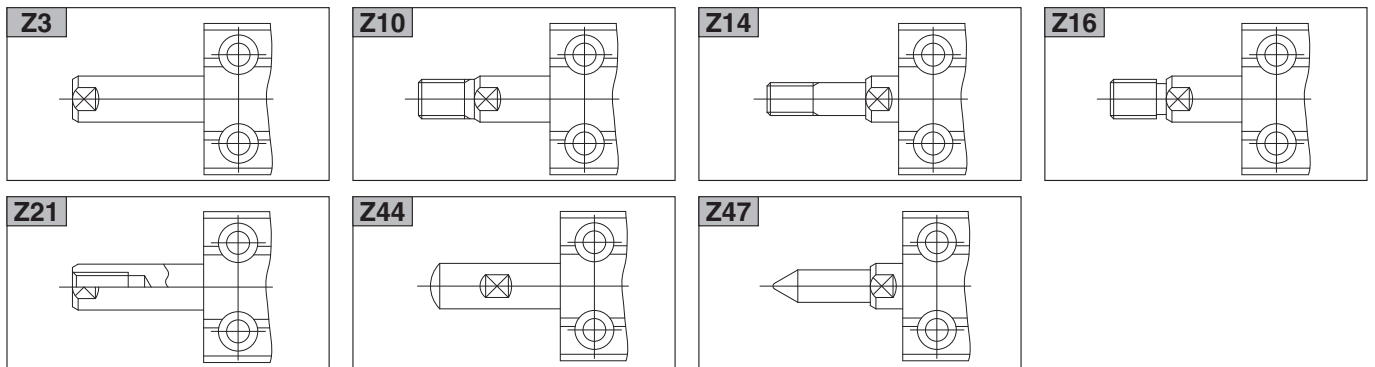

Additional Parts

Note 1: $\phi 6$ [0.236], $\phi 8$ [0.315] and $\phi 10$ [0.394] cannot be disassembled.

2: Be careful that the steel balls do not fall out from the linear guide when doing maintenance on cylinders with guides.

●Packing set for double acting type (including models with guides)

BCZ-PK- (For standard specification)

Cylinder bore

12: For BC12, BCG(N)12
16: For BC16, BCG(N)16
20: For BC20, BCG(N)20
25: For BC25, BCG(N)25
32: For BC32, BCG(N)32
40: For BC40, BCG(N)40
50: For BC50
63: For BC63
80: For BC80
100: For BC100
125: For BC125

* 1 rod seal, 1 piston seal, 1 o-ring and retaining ring

BCZ-PK-R- (For corrosion resistant, clean room specifications)

Cylinder bore

12: For BCR12, CS(L)-BC12, BCG(N)R12, CSL-BCG(N)12
16: For BCR16, CS(L)-BC16, BCG(N)R16, CSL-BCG(N)16
20: For BCR20, CS(L)-BC20, BCG(N)R20, CSL-BCG(N)20
25: For BCR25, CS(L)-BC25, BCG(N)R25, CSL-BCG(N)25
32: For BCR32, CS(L)-BC32, BCG(N)R32, CSL-BCG(N)32
40: For BCR40, CS(L)-BC40, BCG(N)R40, CSL-BCG(N)40
50: For BCR50, CS(L)-BC50
63: For BCR63, CS(L)-BC63
80: For BCR80
100: For BCR100
125: For BCR125

* 1 rod seal, 1 piston seal, 1 o-ring and retaining ring

BCZ-PK-F- (For heat resistant specification)

Cylinder bore

12: For BCF12, BCG(N)F12
16: For BCF16, BCG(N)F16
20: For BCF20, BCG(N)F20
25: For BCF25, BCG(N)F25
32: For BCF32, BCG(N)F32
40: For BCF40, BCG(N)F40
50: For BCF50
63: For BCF63
80: For BCF80
100: For BCF100
125: For BCF125

* 1 rod seal, 1 piston seal, 1 o-ring and retaining ring

BCZ-PK-Y- (For scraper specification)

Cylinder bore

12: For BCY12
16: For BCY16
20: For BCY20
25: For BCY25
32: For BCY32
40: For BCY40
50: For BCY50
63: For BCY63
80: For BCY80
100: For BCY100
125: For BCY125

* 1 rod seal, 1 piston seal, 1 o-ring, 1 scraper, 1 retaining ring



The grease used when you purchase a packing set for disassembly and re-assembly depends on the specification. Contact Koganei for details.



Products that have been disassembled and reassembled are not covered by the warranty.

Additional Parts

Note: $\phi 6$ [0.236], $\phi 8$ [0.315] and $\phi 10$ [0.394] cannot be disassembled.

●Packing set for double acting double rod end type

BCZ-PK-D (For standard specification) **BCZ-PK-R-D** (For corrosion resistant specification)

Cylinder bore
12: For BCD12
16: For BCD16
20: For BCD20
25: For BCD25
32: For BCD32
40: For BCD40
50: For BCD50
63: For BCD63
80: For BCD80
100: For BCD100
125: For BCD125

Cylinder bore
12: For BCDR12
16: For BCDR16
20: For BCDR20
25: For BCDR25
32: For BCDR32
40: For BCDR40
50: For BCDR50
63: For BCDR63
80: For BCDR80
100: For BCDR100
125: For BCDR125

* 2 rod seals, 1 piston seal, 1 o-ring and retaining ring

●Packing set for single acting push and pull type

BCZ-PK-S (For standard specification) **BCZ-PK-R-S** (For corrosion resistant specification)

Cylinder bore
12: For BCSA12, BCTA12
16: For BCSA16, BCTA16
20: For BCSA20, BCTA20
25: For BCSA25, BCTA25
32: For BCSA32, BCTA32
40: For BCSA40, BCTA40
50: For BCSA50, BCTA50

Cylinder bore
12: For BCSAR12, BCTAR12
16: For BCSAR16, BCTAR16
20: For BCSAR20, BCTAR20
25: For BCSAR25, BCTAR25
32: For BCSAR32, BCTAR32
40: For BCSAR40, BCTAR40
50: For BCSAR50, BCTAR50

* 1 rod seal, 1 piston seal, 1 o-ring, retaining ring and 1 spring

●Piping port plugs for cylinders with guides

BCZ-PM (For standard, corrosion resistant, clean room specifications)

Thread size
3: For M3(For BCG(N)8, BCG(N)R8, CSL-BCG(N)8)
5: For M5(For BCG(N)12, BCG(N)R12, CSL-BCG(N)12, BCG(N)16, BCG(N)R16, CSL-BCG(N)16, BCG(N)20, BCG(N)R20, CSL-BCG(N)20, BCG(N)25, BCG(N)R25, CSL-BCG(N)25)



*4 plugs assembled with o-rings in each bag

BCZ-F-PM (For heat resistant specification)

Thread size
3: For M3(For BCG(N)F8)
5: For M5(For BCG(N)F12, BCG(N)F16, BCG(N)F20, BCG(N)F25)

●Back side piping block for cylinders with guides

BCZ-BP (For standard specification) **BCZ-R-BP** (For corrosion resistant, clean room specifications)

Cylinder bore
32: For BCG(N)32
40: For BCG(N)40

Cylinder bore
32: For BCG(N)R32, CSL-BCG(N)32
40: For BCG(N)R40, CSL-BCG(N)40

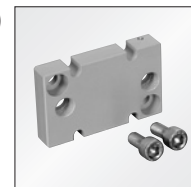

* 1 back side piping block with press fitted steel balls
 1 each of two types of o-rings, 2 mounting bolts

 The grease used when you purchase a packing set for disassembly and re-assembly depends on the specification. Contact Koganei for details.

 Products that have been disassembled and reassembled are not covered by the warranty.

Sensor switches

Solid state type, reed switch type

● Robot cable is standard equipment

Lead wire flexibility is excellent because the conductor used is the same as for robot cables.

Specifications

● Solid State Type

Item \ Model	ZE135□	ZE155□	ZE175□	ZE235□	ZE255□	ZE275□
Wiring method	2-lead wire	3-lead wire with NPN output	3-lead wire with PNP output	2-lead wire	3-lead wire with NPN output	3-lead wire with PNP output
Lead wire direction	Horizontal			Vertical		
Power supply voltage	—	4.5 to 28 VDC		—	4.5 to 28 VDC	
Load voltage	10 to 28 VDC		4.5 to 28 VDC		4.5 to 28 VDC	
Load current	2.5 to 20 mA (at 25°C [77°F], and 10 mA at 60°C [140°F])		40 mA max.		2.5 to 20 mA (at 25°C [77°F], and 10 mA at 60°C [140°F])	
Consumption current	—	8 mA max. (24 VDC)	10 mA max. (24 VDC)	—	8 mA max. (24 VDC)	10 mA max. (24 VDC)
Internal voltage drop ^{Note 1}	4 V max.		2 V max. (0.8 V max if load is less than 10 mA)		4 V max.	
Leakage current	0.7 mA max. (24 VDC, 25°C [77 °F])		50 μA max. (24 VDC)		0.7 mA max. (24 VDC, 25°C [77 °F])	
Response time	1 ms max.					
Insulation resistance	100 M Ω min. (at 500 VDC megger, between case and lead wire terminal)					
Dielectric strength	500 VAC (50/60 Hz) 1 minute (between case and lead wire terminal)					
Shock resistance ^{Note 2}	294.2 m/s ² [30 G] (non-repeated)					
Vibration resistance ^{Note 2}	88.3 m/s ² [9 G] (total amplitude of 1.5 mm [0.059 in], 10 to 55 Hz)					
Protection from environment	IP67 (IEC standard), JIS C0920 (watertight type)					
Operation indicators	Red LED indicator lit when on					
Lead wires	PCCV0.2SQ x 2-lead (brown and blue) x ℓ ^{Note 3}	PCCV0.15SQ x 3-lead (brown, blue, and black) x ℓ ^{Note 3}		PCCV0.2SQ x 2-lead (brown and blue) x ℓ ^{Note 3}	PCCV0.15SQ x 3-lead (brown, blue, and black) x ℓ ^{Note 3}	
Ambient temperature	0 to 60°C [32 to 140°F]					
Storage temperature range	-10 to 70°C [14 to 158°F]					
Mass	15 g [0.53 oz] (for lead wire length A: 1000 mm [39 in]), 35 g [1.23 oz] (for lead wire length B: 3000 mm [118 in]), 15 g [0.53 oz] (for lead wire length 300 mm [11.8 in] with M8 connector)					

Note 1: Internal voltage drop changes with the load current.

2: According to Koganei test standards.

3: Lead wire length ℓ : A; 1000 mm [39 in], B; 3000 mm [118 in], G; 300 mm [11.8 in] with M8 connector only on the ZE175□ and ZE275□

● Reed Switch Type

Item \ Model	ZE101□		ZE102□		ZE201□		ZE202□	
Wiring method	2-lead wire							
Lead wire direction	Horizontal				Vertical			
Load voltage	5 to 28 VDC	85 to 115 VAC (rms)	10 to 28 VDC	85 to 115 VAC (rms)	5 to 28 VDC	85 to 115 VAC (rms)	10 to 28 VDC	85 to 115 VAC (rms)
Load current	40 mA max.	20 mA max.	5 to 40 mA	5 to 20 mA	40 mA max.	20 mA max.	5 to 40 mA	5 to 20 mA
Internal voltage drop ^{Note 1}	0.1 V max. (for load current of 40 mA DC)		3.0 V max.		0.1 V max. (for load current of 40 mA DC)		3.0 V max.	
Leakage current	0mA							
Response time	1 ms max.							
Insulation resistance	100 M Ω min. (at 500 VDC megger, between case and lead wire terminal)							
Dielectric strength	1500 VAC (50/60 Hz) 1 minute (between case and lead wire terminal)							
Shock resistance ^{Note 2}	294.2 m/s ² [30 G] (non-repeated)							
Vibration resistance ^{Note 2}	88.3 m/s ² [9 G] (total amplitude of 1.5 mm [0.059 in], 10 to 55 Hz), resonance frequency 2570 ±250 Hz							
Protection from environment	IP67 (IEC standard), JIS C0920 (watertight type)							
Operation indicators	None		Red LED indicator lit when on		None		Red LED indicator lit when on	
Lead wires	PCCV0.2SQ x 2-lead (brown and blue) x ℓ ^{Note 3}							
Ambient temperature	0 to 60°C [32 to 140°F]							
Storage temperature range	-10 to 70°C [14 to 158°F]							
Contact protection measure	Required (see page 136 under contact protection.)							
Mass	15 g [0.53 oz] (for lead wire length A: 1000 mm [39 in]), 35 g [1.23 oz] (for lead wire length B: 3000 mm [118 in])							

Note 1: Internal voltage drop changes with the load current.

2: According to Koganei test standards.

3: Lead wire length ℓ : A; 1000 mm [39 in], B; 3000mm [118 in]

Sensor switches

Two-color LED solid state type

● Robot cable is standard equipment

Lead wire flexibility is excellent because the conductor used is the same as for robot cables.

Specifications

● Two-color LED solid state type

Item	Model	ZE137□	ZE157□	ZE177□	ZE237□	ZE257□	ZE277□
Wiring method		2-lead wire	3-lead wire with NPN output	3-lead wire with PNP output	2-lead wire	3-lead wire with NPN output	3-lead wire with PNP output
Lead wire direction		Horizontal			Vertical		
Power supply voltage		—	4.5 to 28 VDC		—	4.5 to 28 VDC	
Load voltage		10 to 28 VDC	4.5 to 28 VDC		10 to 28 VDC	4.5 to 28 VDC	
Load current		2.5 to 20 mA (at 25°C [77°F], and 10 mA at 60°C [140°F])	40 mA max.		2.5 to 20 mA (at 25°C [77°F], and 10 mA at 60°C [140°F])	40 mA max.	
Consumption current		—	8 mA max. (24 VDC)	10 mA max. (24 VDC)	—	8 mA max. (24 VDC)	10 mA max. (24 VDC)
Internal voltage drop ^{Note 1}		4 V max.	2 V max. (0.8 V max if load is less than 10 mA)		4 V max.	2 V max. (0.8 V max if load is less than 10 mA)	
Leakage current		0.7 mA max. (24 VDC, 25°C [77 °F])	50 μA max. (24 VDC)		0.7 mA max. (24 VDC, 25°C [77 °F])	50 μA max. (24 VDC)	
Response time		1 ms max.					
Insulation resistance		100 M Ω min. (at 500 VDC megger, between case and lead wire terminal)					
Dielectric strength		500 VAC (50/60 Hz) 1 minute (between case and lead wire terminal)					
Shock resistance ^{Note 2}		294.2 m/s ² [30 G] (non-repeated)					
Vibration resistance ^{Note 2}		88.3 m/s ² [9 G] (total amplitude of 1.5 mm [0.059 in], 10 to 55 Hz)					
Protection from environment		IP67 (IEC standard), JIS C0920 (water-proof type)					
Operation indicators		Appropriate operation range: Green LED indicator lit when on, operation range: Red LED indicator lit when on					
Lead wires		PCCV0.2SQ x 2-lead (brown and blue) x ℓ ^{Note 3}	PCCV0.15SQ x 3-lead (brown, blue, and black) x ℓ ^{Note 3}	PCCV0.2SQ x 2-lead (brown and blue) x ℓ ^{Note 3}	PCCV0.15SQ x 3-lead (brown, blue, and black) x ℓ ^{Note 3}		
Ambient temperature		0 to 60°C [32 to 140°F]					
Storage temperature range		-10 to 70°C [14 to 158°F]					
Mass		15 g [0.53 oz] (for lead wire length A: 1000 mm [39 in]), 35 g [1.23 oz] (for lead wire length B: 3000 mm [118 in]), 15 g [0.53 oz] (for lead wire length 300 mm [11.8 in] with M8 connector)					

Note 1: Internal voltage drop changes with the load current.

2: According to Koganei test standards.

3: Lead wire length ℓ : A; 1000 mm [39 in], B; 3000 mm [118 in], G; 300 mm [11.8 in] with M8 connector only on the ZE177□ and ZE277□

Operation

● Explanation of operation of two-color LED solid state type

ZE137□, ZE157□, ZE177□, ZE237□, ZE257□, ZE277□

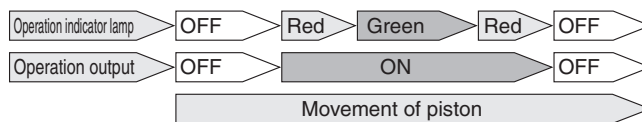

Note: The operating output may become unstable, due to the effects of the operating and installation environments, even if the appropriate operating range (green LED indicator lit) is fixed.

Diagram of inner circuits

● Solid State Type

● ZE135□, ZE235□

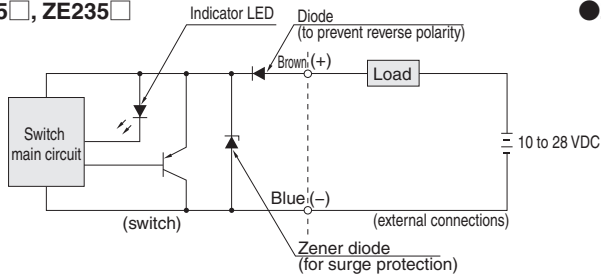

● ZE155□, ZE255□

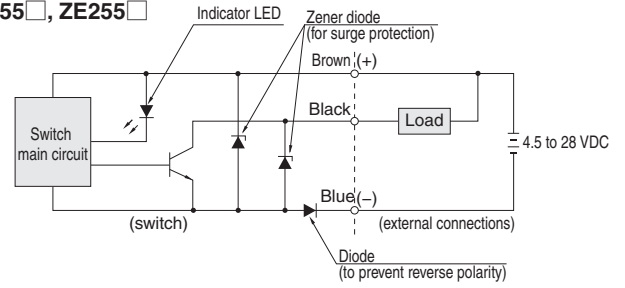

● ZE175□, ZE275□

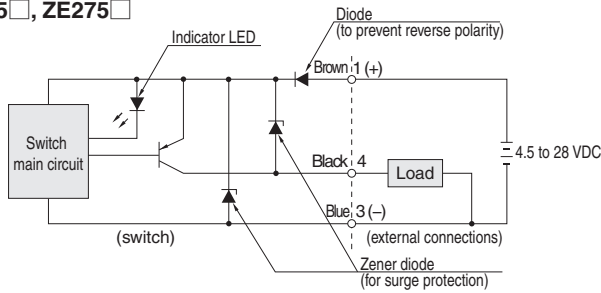

● Two-color LED solid state type

● ZE137□, ZE237□

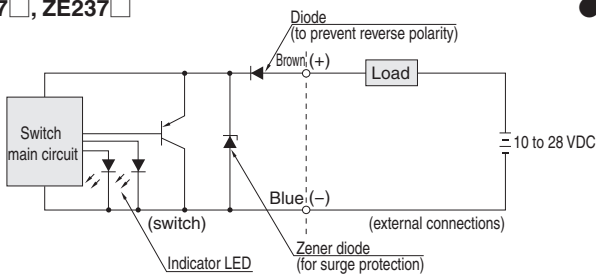

● ZE157□, ZE257□

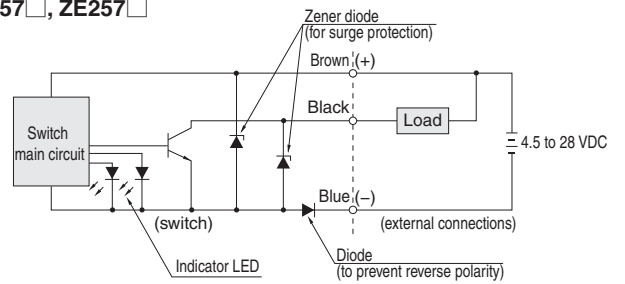

● ZE177□, ZE277□

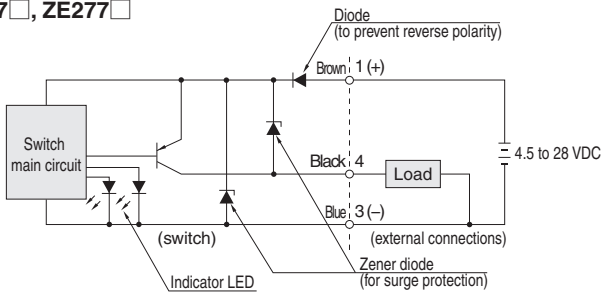

● Reed Switch Type

● ZE101□, ZE201□

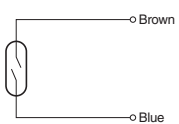

● ZE102□, ZE202□

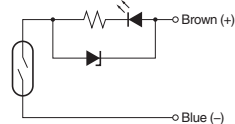

● Horizontal lead wire

● Solid state (ZE135□, ZE155□, ZE175□, ZE137□, ZE157□, ZE177□)

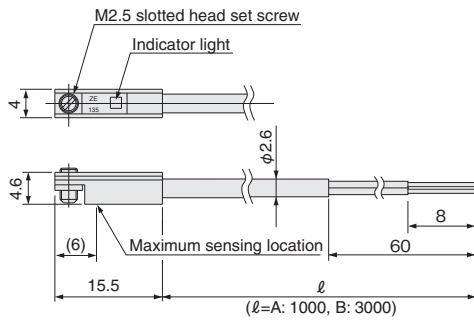

● Reed switch (ZE101□, ZE102□)

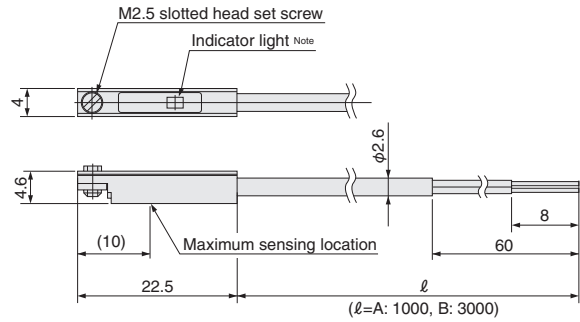

● Solid state (ZE175G, ZE177G)

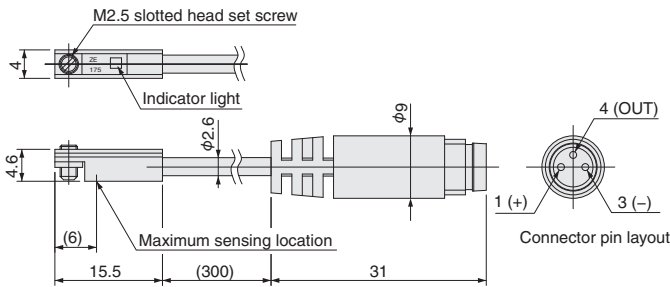

Note: Not available with the ZE101□.

● Vertical lead wire

● Solid state (ZE235□, ZE255□, ZE275□, ZE237□, ZE257□, ZE277□)

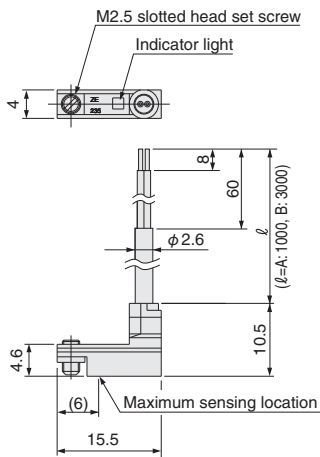

● Reed switch (ZE201□, ZE202□)

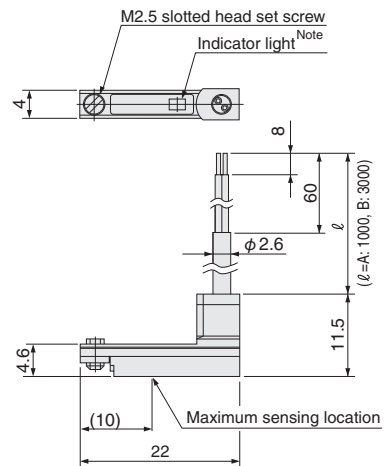

● Solid state (ZE275G, ZE277G)

Note: Not available with the ZE201□.

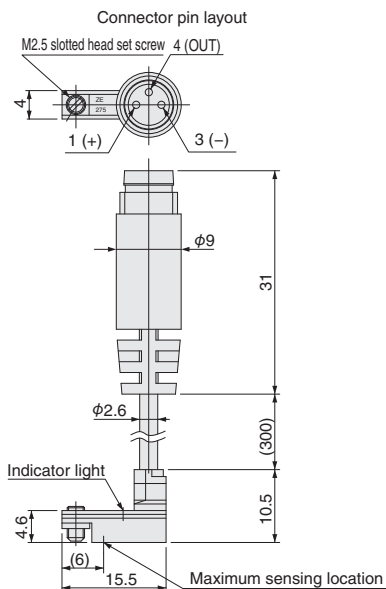

● Horizontal lead wire

● Solid state (ZE135□, ZE155□, ZE175□, ZE137□, ZE157□, ZE177□)

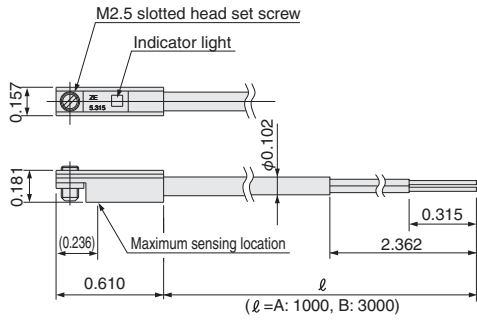

● Reed switch (ZE101□, ZE102□)

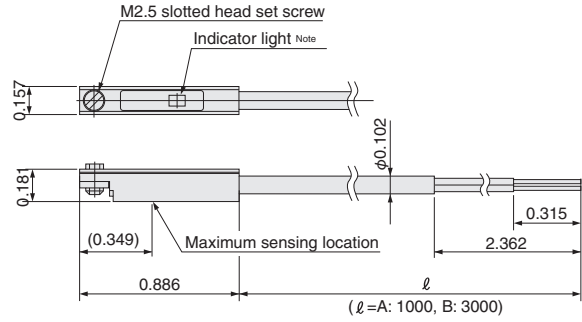

● Solid state (ZE175G, ZE177G)

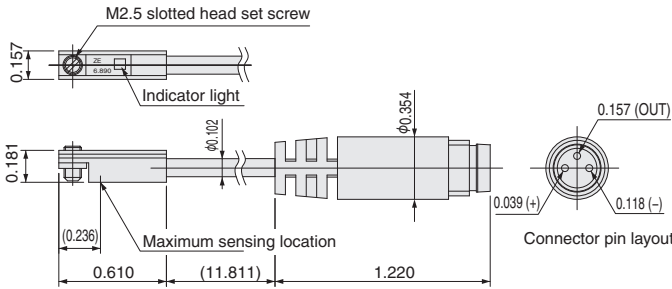

Note: Not available with the ZE101□.

● Vertical lead wire

● Solid state (ZE235□, ZE255□, ZE275□, ZE237□, ZE257□, ZE277□)

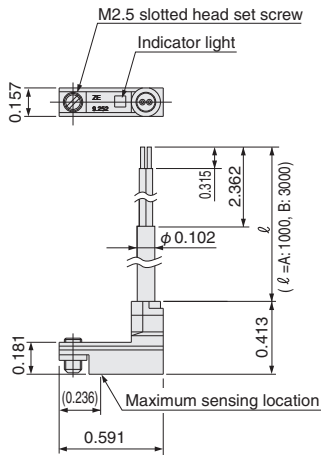

● Reed switch (ZE201□, ZE202□)

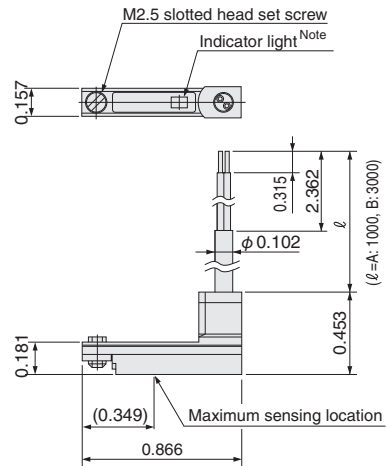

● Solid state (ZE275G, ZE277G)

Note: Not available with the ZE201□.

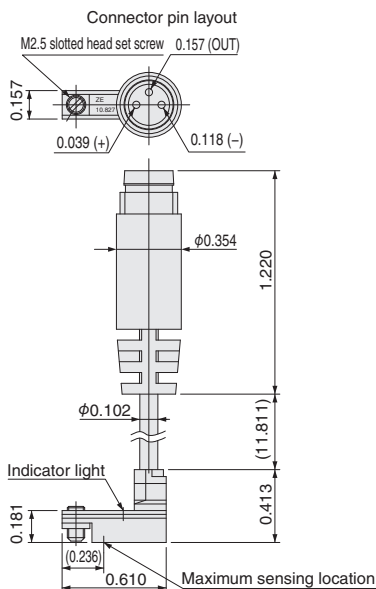

Contact Protection for Reed Switch Type Sensor Switch

In order to use the reed switch type sensor switch safely, take the contact protection measures listed below.

● For connecting an inductive load (electromagnetic relay)

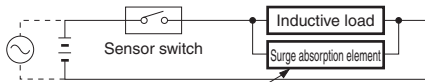

For DC: Diode or CR, etc.

For AC: CR etc.

Diode: Forward current should be more than the circuit current, and for reverse direction, dielectric strength should be 10 times greater or more than the circuit voltage.

C: 0.01 to 0.1 μ F
R: 1 to 4k Ω

● For capacitive surges

(When the lead wire length exceeds 10 m [32.808 ft])

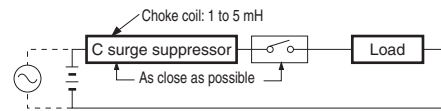

Wiring instructions for the solid state sensor switches

● 2-lead wire

● Basic connection

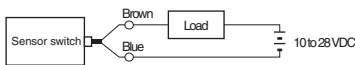

● Connection to relays

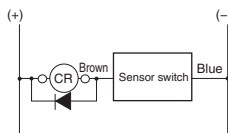

AND (series) connection and OR (parallel) connection

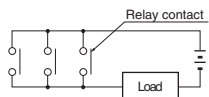
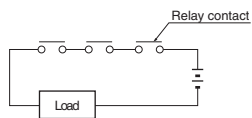
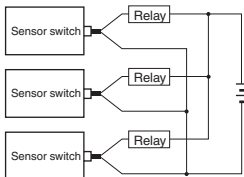

● Connection to solenoid valve

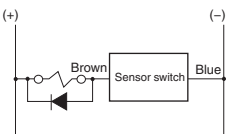

● Connection to programmable controller

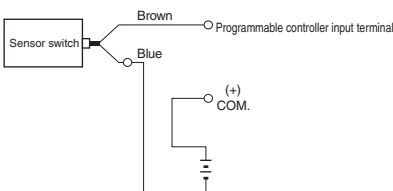

● 3-lead wire with NPN output type

● Basic connection

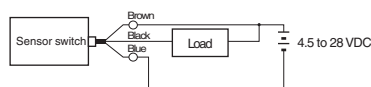

● Connection to relays

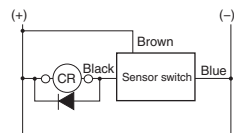

AND (series) connection and OR (parallel) connection

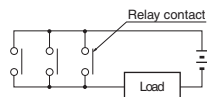
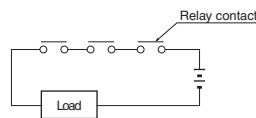
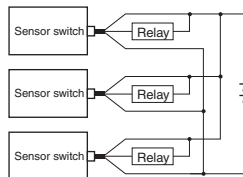

● Connection to solenoid valve

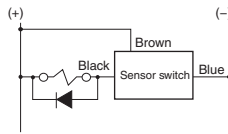

● Connection to programmable controller

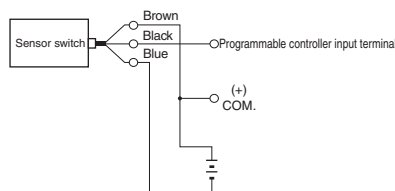

● 3-lead wire with PNP output type

● Basic connection

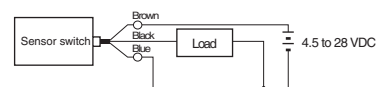

● Connection to relays

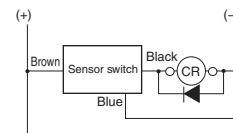

AND (series) connection and OR (parallel) connection

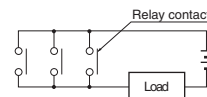
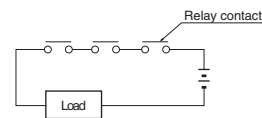
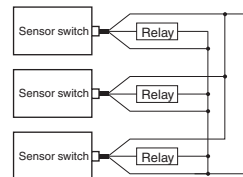

● Connection to solenoid valve

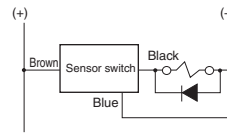

● Connection to programmable controller

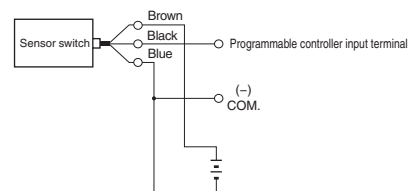

- NOTE**
1. Connect the lead wires according to their color. Incorrect wiring will cause damage to the sensor switch.
 2. The use of a surge protection diode is recommended with the inductive load such as an electromagnetic relay.
 3. Avoid the use of AND (series) connections because the circuit voltage will drop in proportion to the number of sensor switches.
 4. When using an OR (parallel) connection, it is possible to connect sensor switch outputs directly (ex: using corresponding black lead wires). Be aware of load return errors since current leakage increases with the number of switches.

5. Because the sensor switches are magnetically sensitive, avoid using them in locations subject to strong external magnetic fields or bringing them in close proximity to power lines and areas where large electric currents are present. Also avoid using magnetic material for any parts used for mounting. It could result in erratic operation.
6. Do not excessively pull on or bend the lead wires.
7. Avoid using the switches in environments where chemicals or gas are present.
8. Consult the nearest Koganei sales office for use in environments subject to water or oil.

Moving Sensor Switch

- Loosening the screw allows the sensor switch to be moved along the switch mounting groove of the cylinder tube.
- The tightening torque for the screws is 0.1 to 0.2 N·m [0.86 to 1.77 in·lbf].

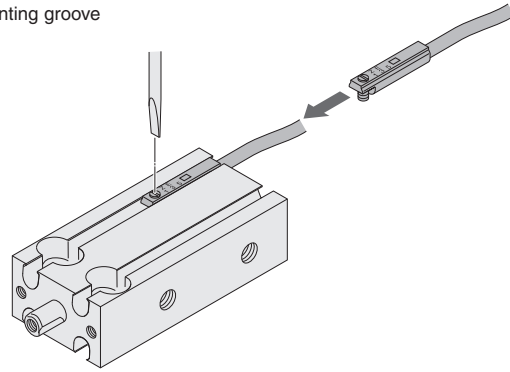

Sensor Switch Operating Range, Response Differential, and Maximum Sensing Location

● Operating range: ℓ

The range from where the piston turns the switch on and the point where the switch is turned off as the piston travels in the same direction.

● Response differential: C

The distance between the point where the piston turns the switch on and the point where the switch is turned off as the piston travels in the opposite direction.

● Solid State Type

unit: mm

Item \ Diameter	6	8	10	12	16	20	25	32	40	50	63	80	100	125
Operating range: ℓ	1.5 to 5		2 to 5			2 to 6			3 to 7				3 to 11	
Response differential: C	0.3 or less													
Maximum sensing location ^{*)}	6													

Note: The values in the table above are reference values. Note: The value from the opposite end of the lead wire. (shown by arrow)

unit: in

Item \ Diameter	0.236	0.315	0.394	0.472	0.630	0.787	0.984	1.260	1.575	1.969	2.480	3.150	3.9	4.9
Operating range: ℓ	0.059 to 0.197		0.079 to 0.197			0.079 to 0.236			0.118 to 0.276				0.118 to 0.433	
Response differential: C	0.012 or less													
Maximum sensing location ^{*)}	0.236													

Note: The values in the table above are reference values. Note: The value from the opposite end of the lead wire. (shown by arrow)

● Reed Switch Type

unit: mm

Item \ Diameter	16	20	25	32	40	50	63	80	100	125	
Operating range: ℓ	3 to 9		4 to 12			6 to 14			7 to 18	8 to 19	8 to 24
Response differential: C	0.3 or less										
Maximum sensing location ^{*)}	10										

Note: The values in the table above are reference values. Note: The value from the opposite end of the lead wire. (shown by arrow)

unit: in

Item \ Diameter	0.630	0.787	0.984	1.260	1.575	1.969	2.480	3.150	3.9	4.9	
Operating range: ℓ	0.118 to 0.354		0.157 to 0.472			0.236 to 0.551			0.276 to 0.709	0.315 to 0.748	0.315 to 0.945
Response differential: C	0.012 or less										
Maximum sensing location ^{*)}	0.394										

Note: The values in the table above are reference values. Note: The value from the opposite end of the lead wire. (shown by arrow)

● Two-color LED solid state type

unit: mm

Item \ Diameter	6	8	10	12	16	20	25	32	40	50	63	80	100	125
Operating range: ℓ	1.5 to 5		2 to 6			3 to 8			4 to 12				5 to 12	
Response differential: C	0.5 or less													
Maximum sensing location ^{*)}	6													

Note: The values in the table above are reference values. Note: The value from the opposite end of the lead wire. (shown by arrow)

unit: in

Item \ Diameter	0.236	0.315	0.394	0.472	0.630	0.787	0.984	1.260	1.575	1.969	2.480	3.150	3.9	4.9
Operating range: ℓ	0.059 to 0.197		0.079 to 0.236			0.118 to 0.315			0.157 to 0.472				0.197 to 0.472	
Response differential: C	0.020 or less													
Maximum sensing location ^{*)}	0.236													

Note: The values in the table above are reference values. Note: The value from the opposite end of the lead wire. (shown by arrow)

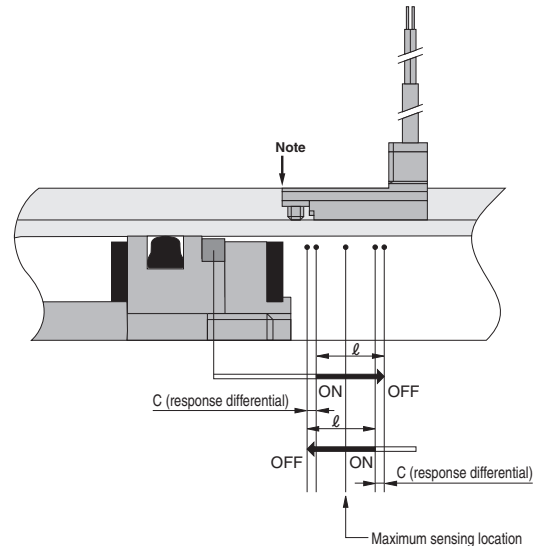

When Mounting the Cylinders with Sensor Switches in Close Proximity

When using it connected to a cylinder, use under conditions using values greater than those shown in the table below.

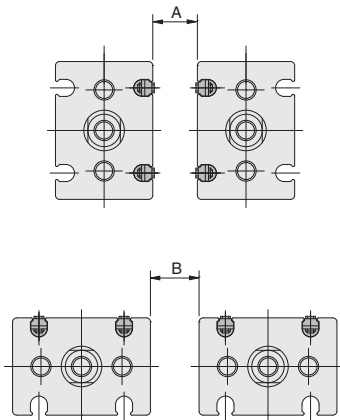

● Reed Switch Type

Cylinder bore	unit: mm	
	A	B
16	12	0
20		
25		
32		
40		
50		
63		
80		
100		
125		

● Solid State Type

Cylinder bore	unit: mm	
	A	B
6	14	0
8		
10		
12		
16		
20		
25		
32		
40		
50		
63		
80		
100		
125		

● Two-color LED Solid State Type

Cylinder bore	unit: mm	
	A	B
6	23	0
8		
10		
12		
16		
20		
25		
32		
40		
50		
63		
80		
100		
125		

Note: Install a shield plate (at least 1 mm [0.039 in] thick magnetic material) between two cylinders to use them in close proximity. However, magnetic materials cannot be used in magnetized environments.

Cylinder bore	unit: in	
	A	B
0.630	0.472	0
0.787		
0.984		
1.260		
1.575		
1.969		
2.480		
3.150		
3.9		
4.9		

Cylinder bore	unit: in	
	A	B
0.236	0.551	0
0.315		
0.394		
0.472		
0.630		
0.787		
0.984		
1.260		
1.575		
1.969		
2.480		
3.150		
3.9		
4.9		

Cylinder bore	unit: in	
	A	B
0.236	0.906	0
0.315		
0.394		
0.472		
0.630		
0.787		
0.984		
1.260		
1.575		
1.969		
2.480		
3.150		
3.9		
4.9		

● For cylinder with guide

● Reed Switch Type

Cylinder bore	unit: mm	
	A	B
16	11	0
20		
25		
32		
40		

● Solid State Type

Cylinder bore	unit: mm	
	A	B
8	23	0
12		
16		
20		
25		
32		
40		

● Two-color LED Solid State Type

Cylinder bore	unit: mm	
	A	B
8	15	0
12		
16		
20		
25		
32		
40		

Cylinder bore	unit: in	
	A	B
0.630	0.433	0
0.787		
0.984		
1.260		
1.575		

Cylinder bore	unit: in	
	A	B
0.315	0.906	0
0.472		
0.630		
0.787		
0.984		
1.260		
1.575		

Cylinder bore	unit: in	
	A	B
0.315	0.591	0
0.472		
0.630		
0.787		
0.984		
1.260		
1.575		

Mounting Position of the End of Stroke Detection Sensor Switch

Mounting the sensor switch in the locations shown (reference values in diagram), the sensor magnet comes to the maximum sensing location of the sensor switch at the end of the stroke.

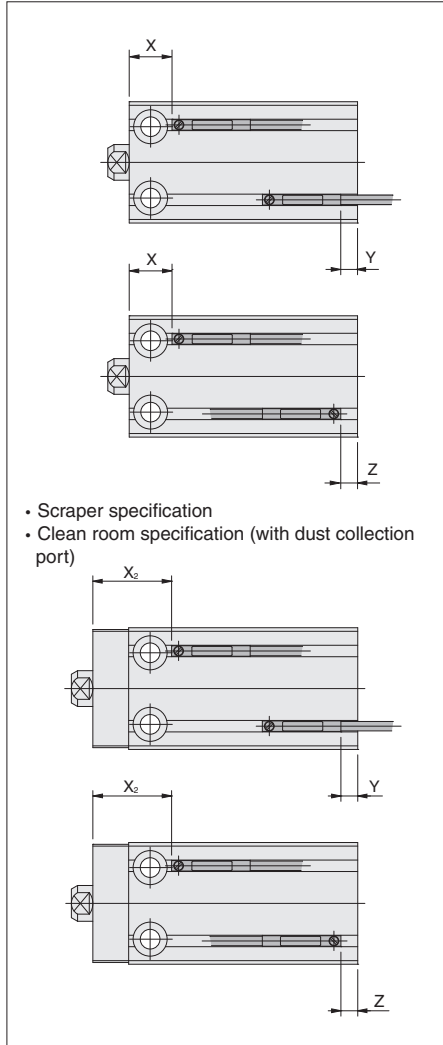

* When the Y dimension is negative, the sensor switch protrudes from the cylinder body.

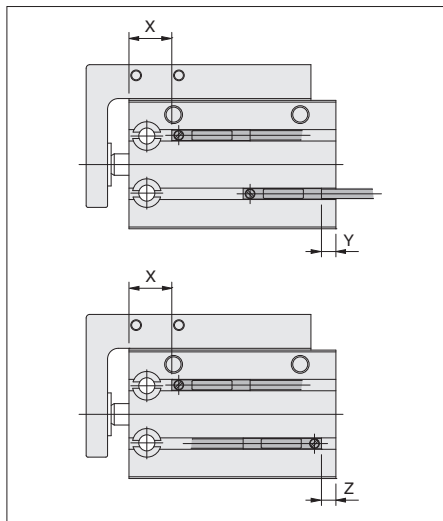

* When the Y dimension is negative, the sensor switch protrudes from the cylinder body.

● Double acting type ● Single acting push type ● Single acting pull type

Solid state type (2-color LED included) unit: mm

Item \ Bore	6	8	10	12	16	20	25	32	40	50	63	80	100	125	
Double acting type	X	10.5	11	11	11	12	15 (20)	16 (21)	17.5	22.5	27.5	33.5	34.5	46.5	53
	X ₂	—	—	21	21	22	25 (30)	26 (31)	32.5	37.5	42.5	53.5	*54.5	*66.5	*73
	Y	0	-0.5	0.5	1.5	2.5	3.5	4.5	7	9	10	12	14	18	19.5
	Z	3.5	3	4	5	6	7	8	10.5	12.5	13.5	15.5	17.5	21.5	23
Push Single acting type	X	25.5	26	26	26	27	30	31	32.5	37.5	47.5	—	—	—	—
	Y	0	-0.5	0.5	1.5	2.5	3.5	4.5	7	9	10	—	—	—	—
	Z	3.5	3	4	5	6	7	8	10.5	12.5	13.5	—	—	—	—
Pull Single acting type	X	25.5	26	26	26	27	30	31	32.5	37.5	47.5	—	—	—	—
	Y	0	-0.5	0.5	1.5	2.5	3.5	4.5	7	9	10	—	—	—	—
	Z	3.5	3	4	5	6	7	8	10.5	12.5	13.5	—	—	—	—

Note: Dimensions in () parentheses are for 5 mm dimensions for scrapper specification only.

Reed Switch Type unit: mm

Item \ Bore	6	8	10	12	16	20	25	32	40	50	63	80	100	125	
Double acting type	X	—	—	—	—	8	11 (16)	12 (17)	13.5	18.5	23.5	29.5	30.5	42.5	49
	X ₂	—	—	—	—	18	21 (26)	22 (27)	28.5	33.5	38.5	49.5	*50.5	*62.5	*69
	Y	—	—	—	—	-0.5	0.5	1.5	4	6	7	9	11	15	16.5
	Z	—	—	—	—	2	3	4	6.5	8.5	9.5	11.5	13.5	17.5	19
Push Single acting type	X	—	—	—	—	23	26	27	28.5	33.5	43.5	—	—	—	—
	Y	—	—	—	—	-0.5	0.5	1.5	4	6	7	—	—	—	—
	Z	—	—	—	—	2	3	4	6.5	8.5	9.5	—	—	—	—
Pull Single acting type	X	—	—	—	—	8	11	12	13.5	18.5	23.5	—	—	—	—
	Y	—	—	—	—	14.5	10.5	11.5	14	16	27	—	—	—	—
	Z	—	—	—	—	17	13	14	16.5	18.5	29.5	—	—	—	—

Note: Dimensions in () parentheses are for 5 mm stroke models. * * Indicates dimensions for scrapper specification only.

● Double acting double rod end type

Solid state type (2-color LED included) unit: mm

Item \ Bore	6	8	10	12	16	20	25	32	40	50	63	80	100	125	
Double acting type	X	10.5	11	11	11	12	15	16	17.5	22.5	27.5	33.5	34.5	46.5	53
	Y	4	4.5	5.5	6.5	7.5	8.5	9.5	12	14	20	22	24	18	19.5
	Z	7.5	8	9	10	11	12	13	15.5	17.5	23.5	25.5	27.5	21.5	23

Reed Switch Type unit: mm

Item \ Bore	6	8	10	12	16	20	25	32	40	50	63	80	100	125	
Double acting type	X	—	—	—	—	8	11	12	13.5	18.5	23.5	29.5	30.5	42.5	49
	Y	—	—	—	—	4.5	5.5	6.5	9	11	17	19	21	15	16.5
	Z	—	—	—	—	7	8	9	11.5	13.5	19.5	21.5	23.5	17.5	19

● Double acting type with guide

Solid State Type unit: mm

Item \ Bore	8	12	16	20	25	32	40	
Double acting type	X	11 (16)	11 (16)	12 (17)	15 (20)	16 (21)	17.5 (22.5)	22.5 (27.5) (32.5 for stroke 10 only)
	Y	-0.5	1.5	2.5	3.5	4.5	12	14
	Z	3	5	6	7	8	15.5	17.5

Note: Dimensions in () parentheses are for mid-stroke models (stroke 5, 15, 25, 35, 45, and 55).

Reed Switch Type unit: mm

Item \ Bore	8	12	16	20	25	32	40	
Double acting type	X	—	—	8 (13)	11 (16)	12 (17)	13.5 (18.5)	18.5 (23.5) (28.5 for stroke 10 only)
	Y	—	—	-0.5	0.5	1.5	9	11
	Z	—	—	2	3	4	11.5	13.5

Note: Dimensions in () parentheses are for mid-stroke models (stroke 5, 15, 25, 35, 45, and 55).

Mounting Position of the End of Stroke Detection Sensor Switch

Mounting the sensor switch in the locations shown (reference values in diagram), the sensor magnet comes to the maximum sensing location of the sensor switch at the end of the stroke.

● Double acting type ● Single acting push type ● Single acting pull type

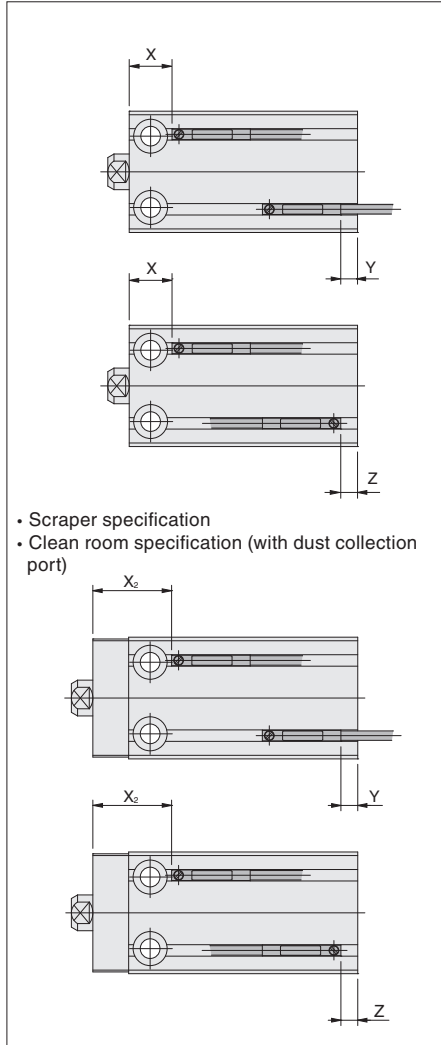

* When the Y dimension is negative, the sensor switch protrudes from the cylinder body.

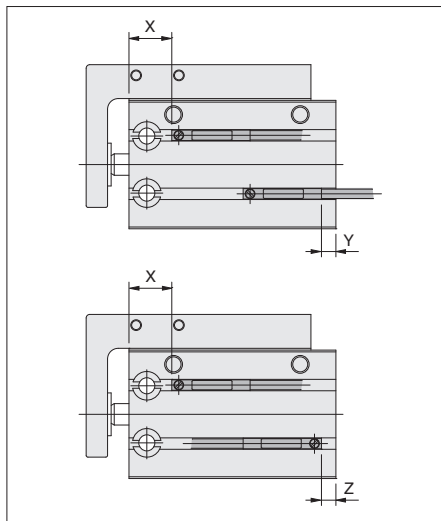

* When the Y dimension is negative, the sensor switch protrudes from the cylinder body.

Solid state type (2-color LED included)

unit: in

Item	Bore	0.236	0.315	0.394	0.472	0.630	0.787	0.984	1.260	1.575	1.969	2.480	3.150	3.9	4.9
Double acting type	X	0.413	0.433	0.433	0.433	0.472	0.591 (0.787)	0.630 (0.827)	0.689	0.886	1.083	1.319	1.358	1.831	2.087
	X ₂	—	—	0.827	0.827	0.866	0.984 (1.181)	1.024 (1.220)	1.280	1.476	1.673	2.106	*2.146	*2.618	*2.874
	Y	0	-0.020	0.020	0.059	0.098	0.138	0.177	0.276	0.354	0.394	0.472	0.551	0.709	0.768
	Z	0.138	0.118	0.157	0.197	0.236	0.276	0.315	0.413	0.492	0.531	0.610	0.689	0.846	0.906
Push Single acting type	X	1.004	1.024	1.024	1.024	1.063	1.181	1.220	1.280	1.476	1.870	—	—	—	—
	Y	0	-0.020	0.020	0.059	0.098	0.138	0.177	0.276	0.354	0.394	—	—	—	—
	Z	0.138	0.118	0.157	0.197	0.236	0.276	0.315	0.413	0.492	0.531	—	—	—	—
Pull Single acting type	X	1.004	1.024	1.024	1.024	1.063	1.181	1.220	1.280	1.476	1.870	—	—	—	—
	Y	0	-0.020	0.020	0.059	0.098	0.138	0.177	0.276	0.354	0.394	—	—	—	—
	Z	0.138	0.118	0.157	0.197	0.236	0.276	0.315	0.413	0.492	0.531	—	—	—	—

Note: Dimensions in () parentheses are for 0.197 in stroke models. * * Indicates dimensions for scraper specification only.

Reed Switch Type

unit: in

Item	Bore	0.236	0.315	0.394	0.472	0.630	0.787	0.984	1.260	1.575	1.969	2.480	3.150	3.9	4.9
Double acting type	X	—	—	—	—	0.315	0.433 (0.630)	0.472 (0.669)	0.531	0.728	0.925	1.161	1.201	1.673	1.929
	X ₂	—	—	—	—	0.709	0.827 (1.024)	0.866 (1.063)	1.122	1.319	1.516	1.949	*1.988	*2.461	*2.717
	Y	—	—	—	—	-0.020	0.020	0.059	0.157	0.236	0.276	0.354	0.433	0.591	0.650
	Z	—	—	—	—	0.079	0.118	0.157	0.256	0.335	0.374	0.453	0.531	0.689	0.748
Push Single acting type	X	—	—	—	—	0.906	1.024	1.063	1.122	1.319	1.713	—	—	—	—
	Y	—	—	—	—	-0.020	0.020	0.059	0.157	0.236	0.276	—	—	—	—
	Z	—	—	—	—	0.079	0.118	0.157	0.256	0.335	0.374	—	—	—	—
Pull Single acting type	X	—	—	—	—	0.315	0.433	0.472	0.531	0.728	0.925	—	—	—	—
	Y	—	—	—	—	0.571	0.413	0.453	0.551	0.630	1.063	—	—	—	—
	Z	—	—	—	—	0.669	0.512	0.551	0.650	0.728	1.161	—	—	—	—

Note: Dimensions in () parentheses are for 0.197 in stroke models. * * Indicates dimensions for scraper specification only.

● Double acting double rod end type

Solid state type (2-color LED included)

unit: in

Item	Bore	0.236	0.315	0.394	0.472	0.630	0.787	0.984	1.260	1.575	1.969	2.480	3.150	3.9	4.9
Double acting type	X	0.413	0.433	0.433	0.433	0.472	0.591	0.630	0.689	0.886	1.083	1.319	1.358	1.831	2.087
	Y	0.157	0.177	0.217	0.256	0.295	0.335	0.374	0.472	0.551	0.787	0.866	0.945	0.709	0.768
	Z	0.295	0.315	0.354	0.394	0.433	0.472	0.512	0.610	0.689	0.925	1.004	1.083	0.846	0.906

Reed Switch Type

unit: in

Item	Bore	0.236	0.315	0.394	0.472	0.630	0.787	0.984	1.260	1.575	1.969	2.480	3.150	3.9	4.9
Double acting type	X	—	—	—	—	0.315	0.433	0.472	0.531	0.728	0.925	1.161	1.201	1.673	1.929
	Y	—	—	—	—	0.177	0.217	0.256	0.354	0.433	0.689	0.748	0.827	0.591	0.650
	Z	—	—	—	—	0.276	0.315	0.354	0.453	0.531	0.768	0.846	0.925	0.689	0.748

● Double acting type with guide

Solid State Type

unit: in

Item	Bore	0.315	0.472	0.630	0.787	0.984	1.260	1.575							
Double acting type	X	0.433 (0.630)	0.433 (0.630)	0.472 (0.669)	0.591 (0.787)	0.630 (0.827)	0.689 (0.886)	0.886(1.083) (1.280 for stroke 0.394 only)							
	Y	-0.020	0.059	0.098	0.138	0.177	0.472	0.551							
	Z	0.118	0.197	0.236	0.276	0.315	0.610	0.689							

Note: Dimensions in () parentheses are for mid-stroke models (stroke 0.197, 0.591, 0.984, 1.378, 1.772, and 2.165).

Reed Switch Type

unit: in

Item	Bore	0.315	0.472	0.630	0.787	0.984	1.260	1.575							
Double acting type	X	—	—	0.315 (0.512)	0.433 (0.630)	0.472 (0.669)	0.531 (0.728)	0.728(0.925) (1.122 for stroke 0.394 only)							
	Y	—	—	-0.020	0.020	0.059	0.354	0.433							
	Z	—	—	0.079	0.118	0.157	0.453	0.531							

Note: Dimensions in () parentheses are for mid-stroke models (stroke 0.197, 0.591, 0.984, 1.378, 1.772, and 2.165).

MEMO

A series of horizontal dashed lines for writing.

Limited Warranty

KOGANEI CORP. warrants its products to be free from defects in material and workmanship subject to the following provisions.

Warranty Period The warranty period is 180 days from the date of delivery.

Koganei Responsibility If a defect in material or workmanship is found during the warranty period, KOGANEI CORP. will replace any part proved defective under normal use free of charge and will provide the service necessary to replace such a part.

Limitations ● This warranty is in lieu of all other warranties, expressed or implied, and is limited to the original cost of the product and shall not include any transportation fee, the cost of installation or any liability for direct, indirect or consequential damage or delay resulting from the defects.

● KOGANEI CORP. shall in no way be liable or responsible for injuries or damage to persons or property arising out of the use or operation of the manufacturer's product.

● This warranty shall be void if the engineered safety devices are removed, made inoperative or not periodically checked for proper functioning.

● Any operation beyond the rated capacity, any improper use or application, or any improper installation of the product, or any substitution upon it with parts not furnished or approved by KOGANEI CORP., shall void this warranty.

● This warranty covers only such items supplied by KOGANEI CORP. The products of other manufacturers are covered only by such warranties made by those original manufacturers, even though such items may have been included as the components.

The specifications are subject to change without notice.

URL <http://www.koganei.co.jp>

E-mail: overseas@koganei.co.jp



KOGANEI CORPORATION

OVERSEAS DEPARTMENT

3-11-28, Midori-cho, Koganei City, Tokyo 184-8533, Japan
Tel: 81-42-383-7271 Fax: 81-42-383-7276

KOGANEI INTERNATIONAL AMERICA, INC.

39300 Civic Center Dr., Suite 280, Fremont, CA 94538, U.S.A.
Tel: 1-510-744-1626 Fax: 1-510-744-1676

SHANGHAI KOGANEI INTERNATIONAL TRADING CORPORATION

Room 2606-2607, Tongda Venture Building No.1, Lane 600, Tianshan Road,
Shanghai, 200051, China
Tel: 86-21-6145-7313 Fax: 86-21-6145-7323

TAIWAN KOGANEI TRADING CO., LTD.

Rm. 2, 13F., No88, Sec. 2, Zhongxiao E. Rd., Zhongzheng Dist., Taipei City 100,
Taiwan (ROC)
Tel: 886-2-2393-2717 Fax: 886-2-2393-2719

KOGANEI KOREA CO., LTD.

6F-601, Tower Bldg., 1005, Yeongdeu-dong, Giheung-gu, Yongin-si, Gyeonggi-do,
446-908, Korea
Tel: 82-31-246-0414 Fax: 82-31-246-0415

KOGANEI (THAILAND) CO., LTD.

3300/90, Tower B, Elephant Tower, 16th Fl., Phaholyothin Road, Chomphon,
Chatuchak, Bangkok 10900, Thailand
Tel: 66-2-937-4250 Fax: 66-2-937-4254

KOGANEI ASIA PTE. LTD.

69 Ubi Road 1, #05-18 Oxley Bizhub, Singapore 408731
Tel: 65-6293-4512 Fax: 65-6293-4513