



New-generation Filter Regulator FRZ Series

Down sizing!
Close side-by-side spacing

Regulator RZ30 Regulator RZ40 Regulator RZ50

Compared to existing model (R600)



Flexible installation orientation

Moisture removal function eliminated for more flexible installation orientation

Improved operability

Improved knob operability and simple bowl installation and removal



New-generation Filter Regulator

FRZ Series

Excellent for air lines with moisture and fluid already removed.

Specialized **30 series** for standalone application



35
[1.378]



Regulator
RZ30



Filter regulator
FRZ30

The **40 and 50 series** can be used in combinations



40
[1.575]



Regulator
RZ40



Filter regulator
FRZ40

50
[1.969]



Regulator
RZ50



Filter regulator
FRZ50

Down sizing

Improved flow rate characteristics allow a smaller configuration (close side-by-side spacing possible).

Flexible installation orientation

Moisture removal function is eliminated for more flexible installation orientation.

Improved operability and maintainability

Improved knob operability and simple bowl installation and removal.

Pressure gauge, pressure switch

Supports □30 [1.181 in] integrated pressure gauges, other pressure gauges, and pressure switches.

Supports a wide variety of environments

Ozone resistance specifications and NCU specifications (copper free)^{Note} are available as standard.

Note: Excluding pressure switch and pressure gauge options.



CAUTION

Read the safety precautions on page 4 before using this product.

Compact design

Improved flow rate characteristics enable a smaller configuration.

*Compared to R600 and RZ50 Koganei Regulator.

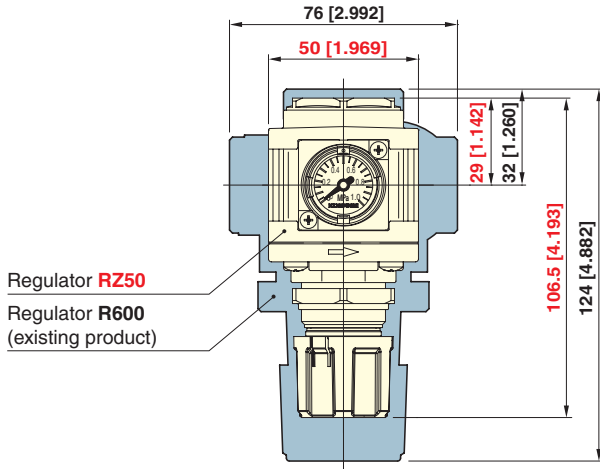

More flexible installation orientation

Moisture and impurities removal functions eliminated for more flexible installation orientation. Bowl can be mounted on the top or sides.

Filter bowl section



Filter regulator
FRZ40

Improved knob operability

- Knob is sized and shaped to turn smoothly with a light touch for easy operation. Also, the knob lock precision has been improved to reduce changes in pressure settings when the knob is locked.
- The status of the lock release can be checked with the caution ring (yellow).



30 [1.181 in] series integrated pressure gauge

- 30 [1.181 in] integrated pressure gauge is compact with almost nothing sticking out. Visibility is also improved with an easy to see 270° swing angle display.

270° swing angle

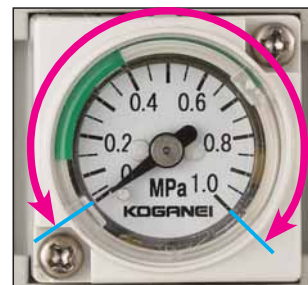

- Flexible change of the pressure setting range (green part) is possible. Freely changeable upper and lower setting limits eliminate the need to remove the front cover (transparent plastic part) and to use special tools.

Pressure setting range

Pressure setting range after change

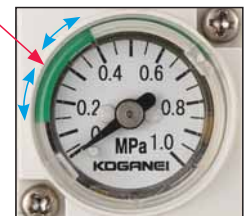
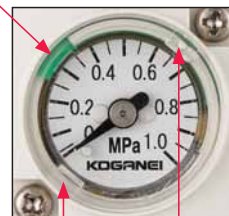

Protrusions (two locations)

The setting pressure range display can be changed as desired by rotating the protrusions (two locations) clockwise or counter clockwise.

*Other pressure gauges and pressure switches are available. See the next page for details.

Improved maintainability

- Bowl can be removed and attached in two easy steps. Filter element can be replaced easily even in small narrow spaces.
- The filter element is a non-woven-fabric. Improved porosity and enlarged circumference area extend its operating life.



Element

Bowl

Pressure gauge, pressure switch

Can select various types of pressure gauges and pressure switches other than the □30 [1.181 in] integrated pressure gauge.



φ 40 [1.575 in] pressure gauge
(1 MPa [145 psi] specification)



φ 40 [1.575 in] pressure gauge
(0.3 MPa [44 psi] specification)



φ 40 [1.575 in] stainless steel
Bourdon tube pressure gauge
(1 MPa [145 psi] specification)



φ 40 [1.575 in] stainless steel
Bourdon tube pressure gauge
(0.3 MPa [44 psi] specification)



Pressure gauge with
electronic switches
(1 MPa [145 psi] specification)



Pressure gauge with
built-in switches
(1 MPa [145 psi] specification)

Pressure switch module

The pressure in the air line is easy to detect with the connecting bracket and integrated compact pressure switch. The set pressure can be adjusted from the front.

Note: Cannot be installed with the 30 series body size.



Residual pressure exhaust valve

The pressure in the air line can be exhausted through a 3-port valve. Better safety through a lock mechanism (with lock hole) while exhausting residual pressure. Also, an easy to see red color is used for better visibility of the operating Knob.

Note: Cannot be installed with the 30 series body size.



Air being supplied



Air being exhausted



Lock hole

Module adapter

These devices are used to connect devices and branch piping and to change pipe sizes for the 40 series and 50 series body sizes.

Note: Cannot be installed with the 30 series body size.



F module
(for connections)



D module
(for connections, with bracket)



T module
(for branches)



DT module
(for branches, with bracket)



S adapter
(for changing pipe size)



DS adapter
(for changing pipe size, with bracket)



Module bracket
(for module adapters)



Coupling plate
(replacement parts)

Bracket

The brackets can be used with all size filter regulators and regulators.



Panel mounting

The diameter, φ 28.5 mm [1.122 in], of the panel mounting holes is the same for all size filter regulators and regulators.

Module adapter

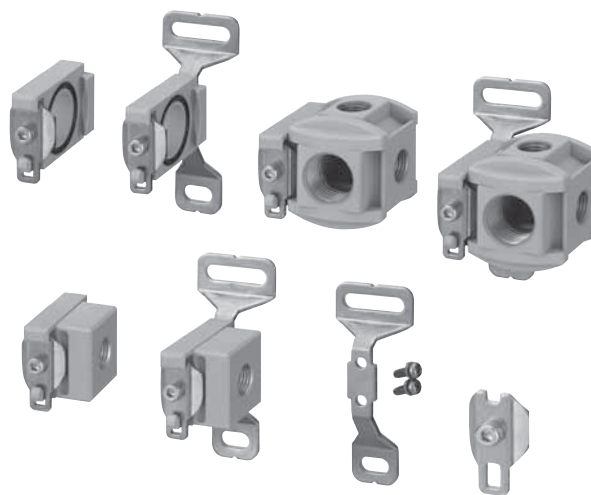

Order codes

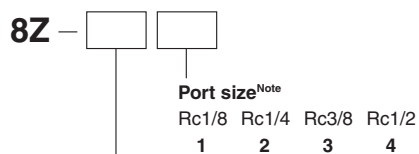

Module adapter

- F — F module (for connecting)^{Note}
- D — D module (for connecting, with bracket)^{Note}
- T — T module (for branching)
- DT — DT module (for branching, with bracket)
- S — S adapter (for changing pipe size)
- DS — DS adapter (for changing pipe size, with bracket)
- DP — Module bracket^{Note}
- FP — Coupling plate^{Note}

Note: The port size cannot be selected for the F module (F), D module (D), module bracket (DP), and coupling plate (FP).

Note: Modules and adapters cannot be assembled with the filter regulator FRZ3□ and the regulator RZ3□.

List of models

F module (for connecting)	D module (For connecting with bracket)	T module (For branching)	DT module (For branching, with bracket)
8Z-F	8Z-D	8Z-T □	8Z-DT □
<p>● Compatible models Filter regulators: FRZ40, FRZ41, FRZ50, FRZ51 Regulators: RZ40, RZ41, RZ50, RZ51 Residual pressure exhaust valve: 50VZ iB-Cyclone: IBC40, IBC50</p>			
S adapter (for changing pipe size)	DS adapter (for changing pipe size, with bracket)	Module bracket	Coupling plate
8Z-S □	8Z-DS □	8Z-DP	8Z-FP
<p>● Compatible models Filter regulators: FRZ40, FRZ41, FRZ50, FRZ51 Regulators: RZ40, RZ41, RZ50, RZ51 Residual pressure exhaust valve: 50VZ iB-Cyclone: IBC40, IBC50</p>			

[Materials of major parts] Connecting bracket, intermediate branch block, piping adapter: die cast aluminum alloy
 Module bracket, coupling plate: Steel plate (electroless nickel plated)

F module dimensions mm [in]

8Z-F

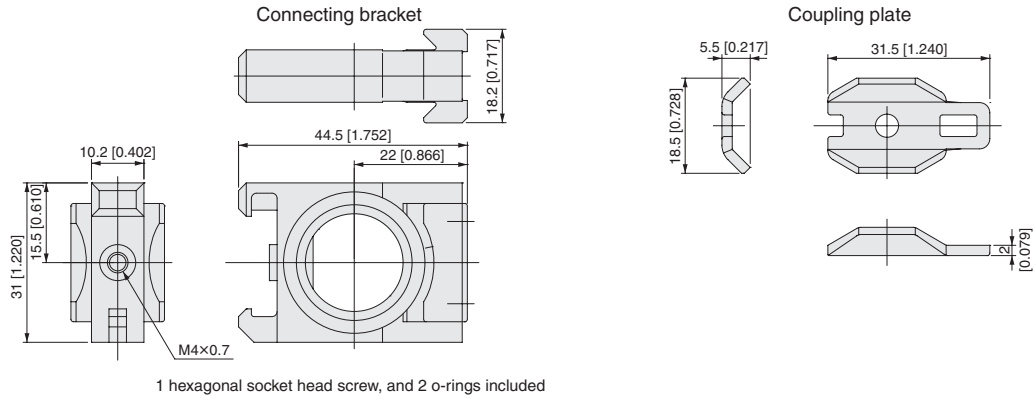

D module dimensions mm [in]

8Z-D

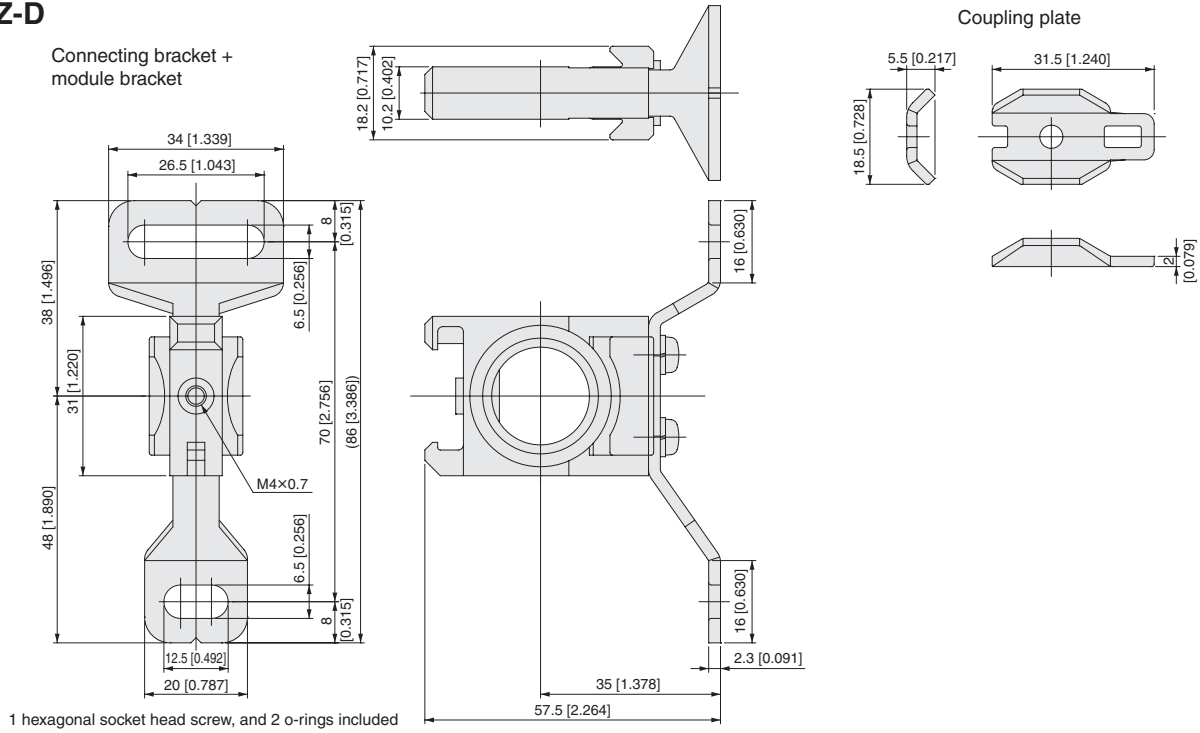

T module dimensions mm [in]

8Z-T

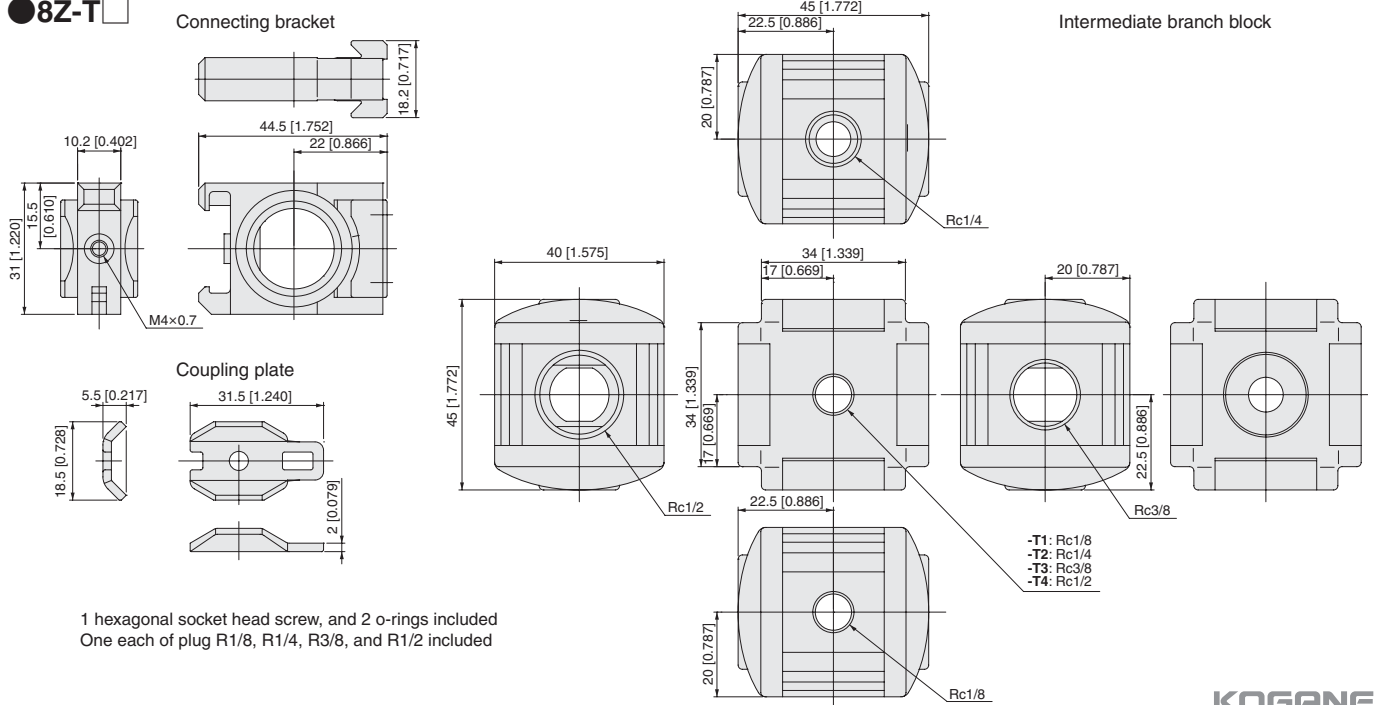

DT module dimensions mm [in]

8Z-DT

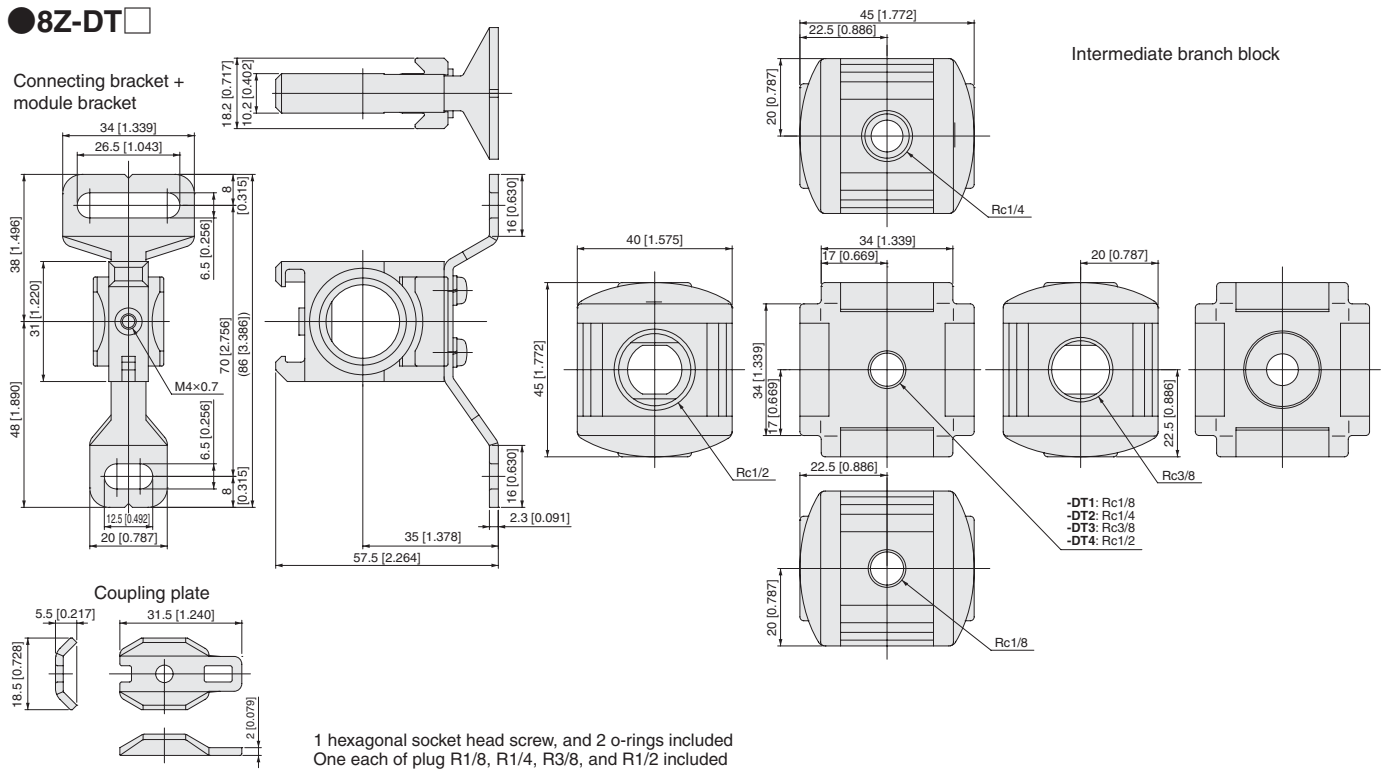

S adapter dimensions mm [in]

8Z-S

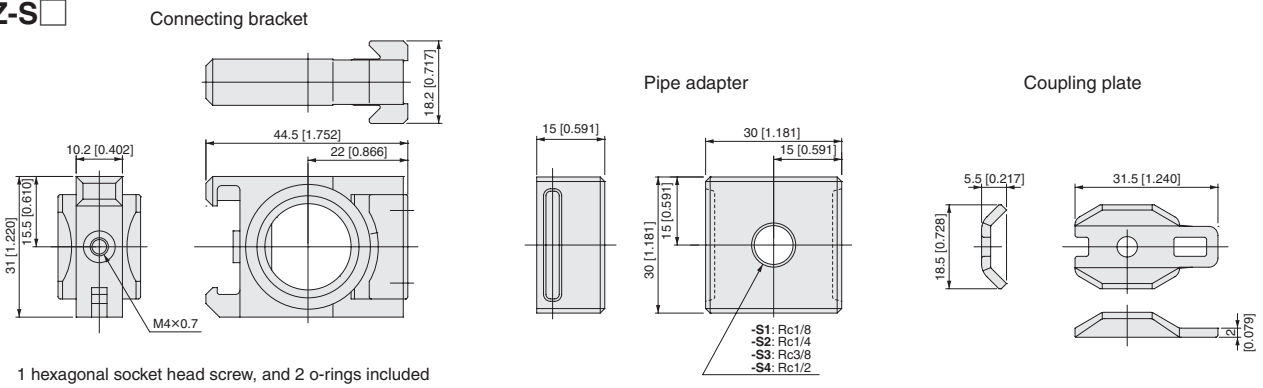

DS adapter dimensions mm [in]

8Z-DS

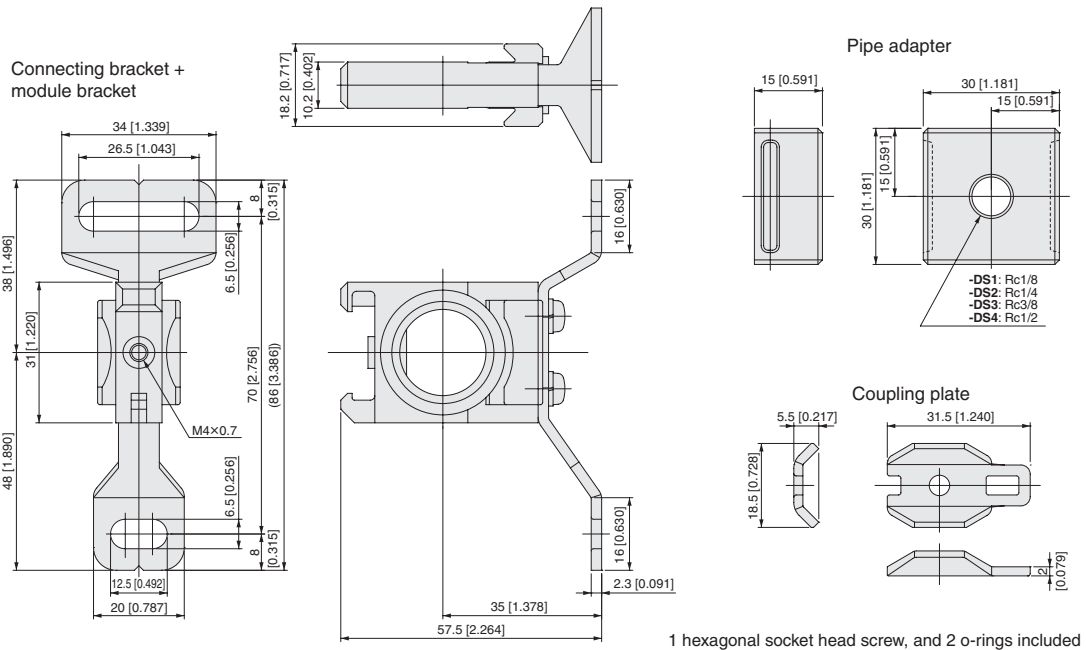

Module bracket dimensions mm [in]

● 8Z-DP

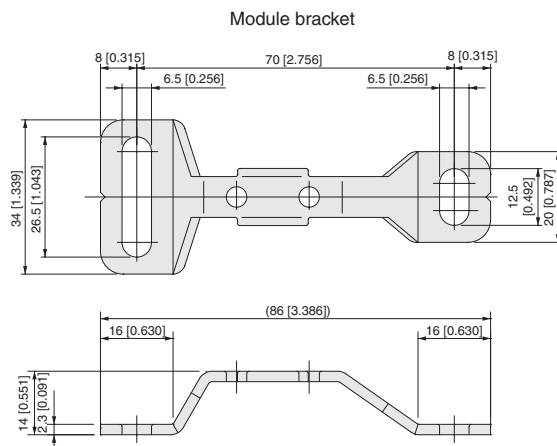

2 phillips head self-tapping screws
and 2 washers included

Coupling plate dimensions mm [in]

● 8Z-FP

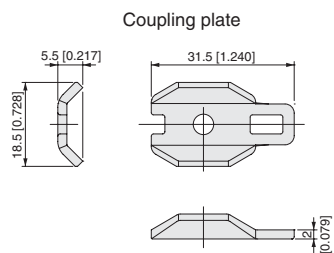

1 hexagonal socket screw included

Bracket

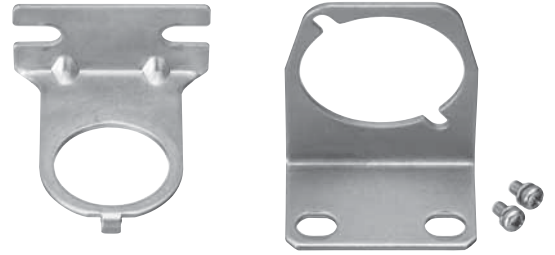

Bracket shape and applicable devices

Applicable model	Bracket model	Remarks	
Filter regulator	FRZ3□, FRZ4□, FRZ5□	8Z-BK	Option to support the product body.
Regulator	RZ3□, RZ4□, RZ5□	8Z-BK	Option to support the product body.
Residual pressure exhaust valve	50VZ	8Z-BV	Option to support the product body.

[Materials of major parts] Steel plate (electroless nickel plated)

Bracket dimensions mm [in]

■ For filter regulators and regulators

● 8Z-BK

Bracket

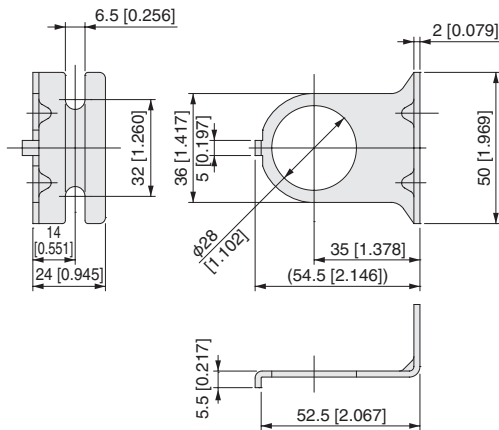

■ For residual pressure exhaust valve

● 8Z-BV



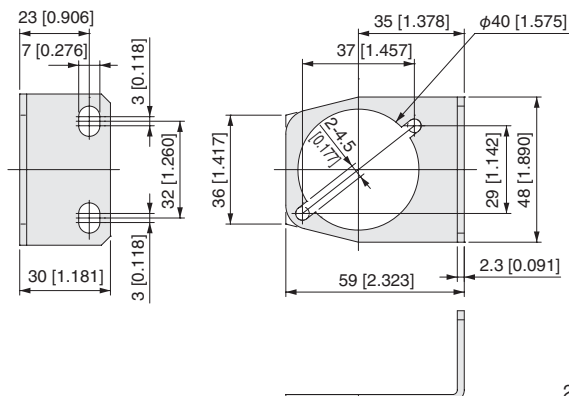

Bracket



2 cross-head pan screws included

Before selecting and using the products, please read all safety precautions carefully to ensure proper product use. The safety precautions described below are to help you use the product safely and correctly, and to prevent injury or damage to you, other people, and assets.
 Always adhere to the following safety regulations: ISO4414 (Pneumatic fluid power - General rules and safety requirements for systems and their components) and JIS B 8370 (General rules relating to pneumatic systems).

The directions are ranked according to degree of potential danger or damage: "DANGER", "WARNING", "CAUTION", and "ATTENTION".

 DANGER	Indicates situations that can be clearly predicted as dangerous. Failure to avoid the situation creates the risk of death or serious injury. It could also result in damage or destruction of assets.
 WARNING	Indicates situations that, while not immediately dangerous, could become dangerous. Failure to avoid the situation creates the risk of death or serious injury. It could also result in damage or destruction of assets.
 CAUTION	Indicates situations that, while not immediately dangerous, could become dangerous. Failure to avoid the situation creates the risk of minor or semi-serious injury. It could also result in damage or destruction of assets.
 ATTENTION	While there is little chance of injury, this content refers to points that should be observed for appropriate use of the product.

■ This product was designed and manufactured for use in general industrial machinery.

- When selecting and handling equipment, the system designer or another person with sufficient knowledge and experience should always read the safety precautions, catalog, instruction manual and other literature before commencing operation. Improper handling is dangerous.
- After reading the instruction manual, catalog, and other documentation, always store them in a location that allows easy availability for reference to users of this product.
- Whenever transferring or lending the product to another person, always attach the catalog, instruction manual, and other information to the product where they are easily visible in order to ensure that the new user can use the product safely and properly.
- The danger, warning and caution items listed under these safety precautions do not cover all possible contingencies. Read the catalog and instruction manual carefully, and always keep safety first.

 **DANGER**

- Do not use the product for the purposes listed below:
 1. Medical equipment related to maintenance or management of human lives or bodies.
 2. Machines or equipment designed for the purpose of moving or transporting people.
 3. Critical safety components in mechanical devices.
 This product has not been planned or designed for purposes that require high levels of safety. Using the product in any of the ways described above creates the risk of loss of human life.
- Do not use the product in locations with or near dangerous substances such as flammable or ignitable substances. This product is not explosion-proof. Doing so creates the risk of ignition and fire.
- When mounting the product and workpiece, always make sure they are firmly supported and secured in place. Falling, dropping, or abnormal operation of the product creates the risk of personal injury.
- People using a pacemaker or other similar medical devices should keep a distance of at least one meter [3.28 ft] away from the product. There is a strong magnet inside the product and the magnetic field of this magnet may cause a pacemaker to malfunction.
- Never attempt to modify the product. Doing so can cause malfunctions and create the risk of personal injury, electric shock, fire, etc.
- Never attempt inappropriate disassembly, assembly or repair of the product relating to basic construction, or to its performance or to functions. Doing so creates the risk of injury, electric shock, fire, etc.
- Do not splash water on the product. Spraying it with water, washing it, or using it under water could result in malfunction of the product leading to injury, electric shocks, fire, etc.
- While the product is in operation, avoid touching it with your hands or otherwise approaching too close. Also, do not attempt to make any adjustments to internal or attached mechanisms, or to perform any type of adjustment (disconnecting cable connectors, adjusting pressure switches, disconnecting tubes or sealed plugs, adjusting the product's mounting position, etc.) while the product is in operation. Falling, dropping, or abnormal operation of the product creates the risk of personal injury.

 **WARNING**

- Because Koganei products are designed for use under a wide variety of conditions, decisions concerning conformance with a particular system should be made upon the careful evaluation by the person in charge of system design.

- Assurances concerning expected system performance and safety are the responsibility of the designer who decides system conformity. Be sure to use the latest catalogs and technical materials to study and evaluate specification details, to consider the possibility of machine breakdown, and to configure a system that ensures fail-safe safety and reliability.
- Do not use the product in excess of its specification range. Doing so creates the risk of product breakdown, loss of function, or damage. It could also drastically reduce operating life.
 - Before supplying air or electricity to the device and before starting operation, always conduct a safety check of the area of machine operation. Unintentional supply of air or electricity creates the risk of injury due to contact with moving parts.
 - Do not touch terminals, switches, or other parts, while power is turned on. Doing so creates the risk of electric shock and malfunction.
 - Do not allow the product to be thrown into fire. Doing so creates the risk of explosion resulting in the release of toxic gases.
 - Do not sit on the product, place your foot on it, or place other objects on it. Doing so creates the risk of injury due to tripping or the product tipping over, resulting in product damage and abnormal, erratic, or runaway operation.
 - Before conducting maintenance, inspection, repair, replacement, or any other similar procedure, always completely cut off the air supply and confirm that residual pressure inside the product or in piping connected to the product is atmospheric pressure. In particular, be aware that residual air will still be in the compressor or storage tank. The actuator may move abruptly if residual air pressure remains inside the piping, causing injury.
 - Use safety circuits or design a system that prevents damage to machinery or injury to personnel when the machine is shut down due to an emergency stop or electrical power failure.
 - Before performing any kind of wiring work, be sure to turn off power. Failure to do so creates the risk of electric shock.
 - Do not allow lead wires and other cords to become damaged. Allowing a cord to become cut, bent excessively, pulled, rolled up, placed under heavy objects, or squeezed between two objects creates the risk of current leaks or defective continuity that can lead to fire, electric shock, or abnormal operation.
 - Do not connect or disconnect connectors while power is turned on. Also, never apply unnecessary force to connectors. Doing so creates the risk of personal injury, device damage, and electric shock due to abnormal machine operation.
 - Always check the catalog and other reference materials for correct product wiring and piping. Improper wiring and piping creates the risk of damage to and abnormal operation of the actuator, etc.
 - After completing wiring work, check to make sure that all connections are correct before turning on power.
 - After completing piping work, check to make sure that the circuit is correct before supplying air.

Safety precautions (FRZ series)

- Do not use any type of medium that is not specifically stipulated in the specifications. Using a non-specified medium could lead to loss of function in the short term, sudden degradation of performance, and a reduced operating life.
- In initial operations after the equipment has been idle for 48 hours or more, or has been in storage, there is a possibility that contacting parts may have become stuck, resulting in equipment operation delays or in sudden movements. Before these initial operations, always run a test to check that operating performance is normal.
- Do not use the product in locations that are subject to direct sunlight (ultraviolet rays); locations with high humidity and temperature, dust, salt, or iron powder. Do not use fluids in the product or use the product in an environment that includes corrosive fluids such as organic solvents, phosphate ester type hydraulic oil, sulfur dioxide, chlorine gas, flon gas, ozone, acids, alkaline, etc. It could lead to early shutdown of some functions, a sudden degradation of performance, and a reduced operating life. For information about materials, see Major Parts and Materials.
- When the device is not used for long periods (over 30 days), it is possible that the contacting parts may have become stuck leading to delayed operation or sudden movements, resulting in injury. Check for proper operation a minimum of once every 30 days.
- Do not place the wiring that controls the pressure switch near power lines running a large current, powerful magnetic fields, or where power surges occur. It could cause erratic operation.
- Do not use the product at the beach in direct sunlight, near mercury vapor lamps, or near equipment that generates ozone. Ozone causes rubber components to deteriorate resulting in reduced performance, or degradation or stop of functions.
- Do not use in locations where there is a heat source nearby or that are subject to radiated heat.

CAUTION

- When mounting the product, leave room for adequate working space around it. Failure to do so will make it more difficult to conduct daily inspections or maintenance, which could eventually lead to system shutdown or damage to the product.
- Whenever transporting or installing a heavy product, use a lift or supports to securely support it, and use several people to help lift it and take other precautions to ensure personal safety.
- Do not scratch, dent, or deform the product by climbing on it, using it as a scaffold, or placing objects on top of it. Doing so creates the risk of damage to or breakage of the product, resulting in operational shutdown or degraded performance.
- Always post an "operations in progress" sign for installations, adjustments, or other operations, to avoid unintentional supplying of air or electrical power, etc. Unintentional supplying of air or electricity can cause electric shock or sudden operation and may result in injury.
- Do not bring any magnetic media or memory within one meter [3.28 ft] of the product. There is a strong magnet inside the product and the magnetic field of this magnet may damage the data on the magnetic media.
- If an electric leakage occurs on the control circuit, it may cause the product to operate unexpectedly. Protect the control circuit from electricity leaks so that electricity leaks do not exceed the allowance in the product specifications.
- Use the specified lubricant to lubricate sliding parts. Not doing so leads to changes in the physical properties, deterioration of the materials used, or reduced functionality.
- Do not block the product's vent holes. The pressure will fluctuate if the air volume changes during operations. If the vents are blocked the pressure balance will be disrupted, operations will no longer be as expected resulting in injury or damage to equipment.
- Use in extremely dry air under temperatures lower than -20°C [-4°F] may affect the quality of the lubricating oil used. This creates the risk of degraded performance, loss of function, or other problems

ATTENTION

- When considering the possibility of using this product in situations or environments not specifically noted in the catalog or instruction manual, or in applications where safety is an

important requirement such as in aircraft equipment, combustion equipment, leisure equipment, safety equipment, and other places where human life or assets may be greatly affected, take adequate safety precautions such as allowing plenty of margin for ratings and performance, or fail-safe measures. Contact the sales department at Koganei regarding use in such applications.

- Use a protective cover and other means to ensure that the operating parts of mechanical devices are isolated and do not come into direct contact with human bodies.
- Do not configure control of the actuator in a way that could cause workpieces to fall due to power failure. Configure control of the system to prevent workpieces and other items from falling due to power failure or by emergency stops of mechanical devices.
- Attach a muffler to the exhaust port. It will reduce the noise during exhaust.
- Lock the pressure regulation knob after regulating the pressure.
- When handling the product, wear protective gloves, safety glasses, safety shoes, and other protective clothing.
- When the product can no longer be used or is no longer necessary, dispose of it appropriately as industrial waste.
- Pneumatic equipment can exhibit degraded performance and function over its operating life. Always conduct daily inspections of the pneumatic equipment, and confirm that all requisite system functions are satisfied, to prevent accidents from happening.
- For inquiries about the product, consult your nearest Koganei sales office or Koganei Overseas Department. The addresses and telephone numbers are shown on the back cover of this catalog.

Other precautions

- Always observe the following items.
 1. When using this product in pneumatic systems, always use genuine Koganei parts or compatible parts (recommended parts).
When conducting maintenance and repairs, always use genuine Koganei parts or equivalent parts (recommended parts).
Always observe the prescribed methods and procedures.
 2. Never attempt inappropriate disassembly or assembly of the product relating to basic configurations, or its performance or functions.

Koganei shall not be held responsible for any problems that occur as a result of these items not being properly observed.

Warranty and General Disclaimer

1. **Warranty Period**
Koganei warrants this product for a period of no more than 180 days from the date of delivery.
2. **Scope of Warranty and General Disclaimer**
 - (1) The Koganei product warranty covers individual products. When a product purchased from Koganei or from an authorized Koganei distributor malfunctions during the warranty period in a way that is attributable to Koganei responsibility, Koganei will repair or replace the product free of charge. Even if a product is still within the warranty period, its durability is determined by its operation cycles and other factors. Contact your nearest Koganei sales office or the Koganei overseas department for details.
 - (2) Koganei shall not be held responsible for any losses or for any damage to other machinery caused by breakdown, loss of function, or loss of performance of Koganei products.
 - (3) Koganei shall not be held responsible for any losses due to use or storage of the product in a way that is outside of the product specifications prescribed in Koganei catalogs and the instruction manual, and/or due to actions that violate the mounting, installation, adjustment, maintenance and other safety precautions.
 - (4) Koganei shall not be held responsible for any losses caused by breakdown of the product due to factors outside the responsibility of Koganei, including but not limited to fire, natural disaster, the actions of third parties, and intentional actions or errors by you.

Handling instructions and precautions

Precautions for the FRZ series

Design and selection

● Selection

Look at the "Handling Instructions and Precautions", "Specifications", "Various Characteristics", "Dimensions", and other technical materials for each product to make the correct decision.

Mounting (installation) and piping

● Mounting (installation) direction, support, and securing

1. The products cannot be mounted (installed) if a bending moment or twisting moment is applied to the product or piping.



Applying bending moment or twisting moment may damage the product.

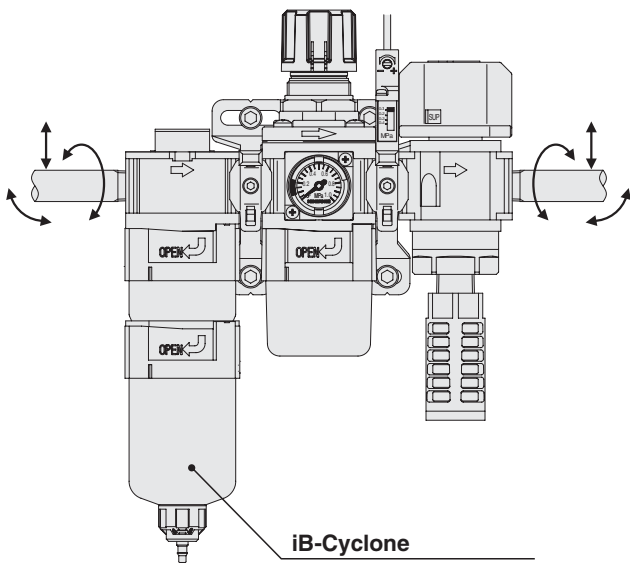

*See the back of the catalog.

2. Do not attach piping so that just one side is fixed as shown in the following diagram. Support external piping separately.



Operating the knob and the moment caused by the OUT (secondary) side pipes may damage the product's piping connections.

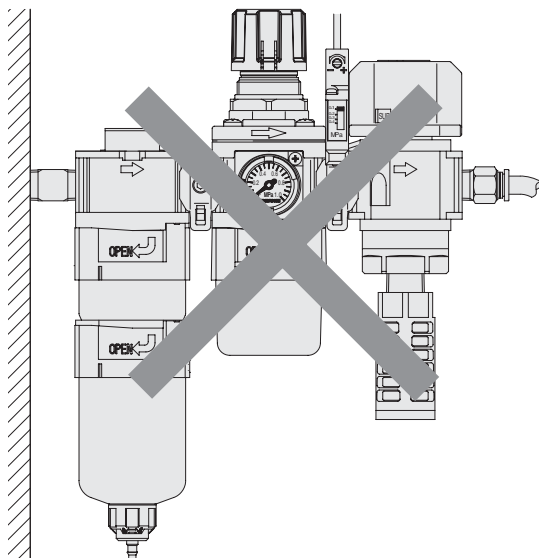

3. Use the D□ module or a bracket to install all the products.
4. The product can be mounted (installed) in any direction. It is also possible to install it with the bowl of the filter on top.



5. When mounting (installing) the product, always make sure it is secured and sufficiently supported.



If the product is not securely fixed in place, it may fall over, be dropped, or operate abnormally and may cause an injury.

● Maintenance space requirements

Assure there is sufficient space for maintenance inspections and maintenance work. See the dimension diagrams for each of the products regarding the maintenance space.



If there is not enough allowance for maintenance space, it will be impossible to remove the filter regulator bowl assembly and replace the filter.



If there is not enough allowance for maintenance space, it will be impossible to do maintenance inspections and maintenance work so the equipment may stop or the product may be damaged.

● Direction of flow

1. Connect the filter regulators and regulators so that the medium flows in the IN port (primary) side and out the OUT port (secondary) side.
2. Connect the residual pressure exhaust valves so that the medium flows from the 1 (P) port (primary) side to the 2 (A) port (secondary) side.
3. Use the flow marks on the products to identify the direction of flow of the medium in the filter regulators, regulators, and residual pressure exhaust valves. See the "Handling Instructions and Precautions" for each product regarding the relationship of the flow marks and direction of flow of the medium being used (filter regulators, regulators on page 8 and residual pressure exhaust valves on page 12).



Connecting the products so the medium flows in reverse will cause the product to stop functioning and damage it.

Handling instructions and precautions

Precautions for the FRZ series

●Attaching steel pipes and fittings

If steel pipes and fittings are attached to the threaded sections of the aluminum die-cast parts of the product, tighten them to the torque recommended in our standards.

NOTE Tightening with excessive torque may damage the product or injure workers or operators.

Recommended tightening torque

Connecting thread	M5	1/8	1/4	3/8	1/2
Torque	1 to 1.5 [0.74 to 1.11]	7 to 9 [5.2 to 6.6]	12 to 14 [8.9 to 10.3]	22 to 24 [16.2 to 17.7]	28 to 30 [20.7 to 22.1]

NOTE Use a tightening torque of 3.0 to 5.0 N·m [2.21 to 3.69 ft·lbf] if the various pressure gauges are mounted on the Rc1/4 pressure port plate.

NOTE If a muffler or something is attached to the 3 (R) port of the residual exhaust valve, tighten it to 1.8 to 2.2 N·m [1.33 to 1.63 ft·lbf].

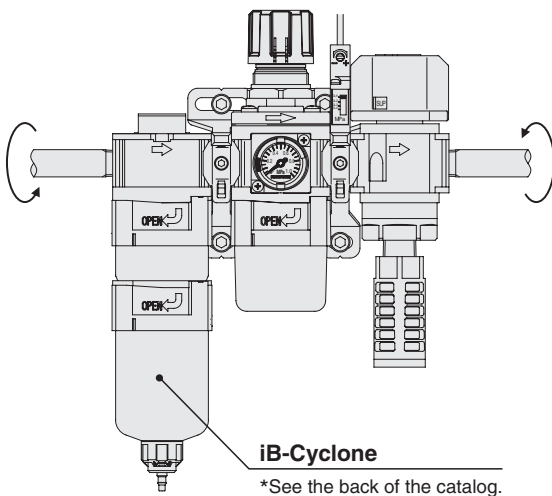

●Preventing contamination by foreign matter

1. Remove all foreign matter, such as metal chips, cutting oil, or dirt, from inside pipes with an air blower (flushing) and thorough washing before fitting the pipes.
2. Do not allow foreign matter, such as metal chips, or sealing tape from the piping threads, to get into the pipes when fitting the pipes.

NOTE Foreign matter entering the piping may damage the product or reduce its performance and service life.

3. Wrap the sealing tape in the direction as shown in the diagram below leaving 1.5 to 2 threads uncovered. When using liquid sealant, apply a suitable amount and leave 1.5 to 2.0 threads uncovered.

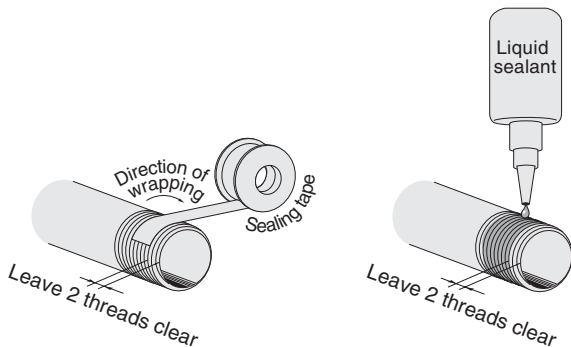

NOTE If the sealing tape or sealant gets on the lip of pipes and fittings, bits of it may get into the pipes and cause air leaks.

4. If you are using liquid sealant, do not get it on the polycarbonate parts (the bowl of the filter regulator and the front cover of the pressure gauge).

NOTE If liquid sealant gets on the polycarbonate parts, it may damage them.

Medium and operating environment

●Media

1. Use clean air (through 5 μm or smaller filter) for the supply medium. Contact the nearest Koganei sales office or overseas department if you are considering using something other than cleaned air.

2. Cannot use air that contains moisture and fluid.

NOTE Using air that contains moisture and fluids will cause the product's functions to stop after a short period and will reduce the product performance and service life.

3. If air that contains moisture and fluids is used, or if it is possible that they may be mixed in with the air being used, the moisture and fluids must be removed completely by installing a moisture and fluid removal device (such as the iB-Cyclone*) on the primary side. *See the back of the catalog.

4. Avoid using media that is prone to extreme pulsating or surging.

NOTE Medium prone to extreme pulsating or surges will cause the product's functions to stop after a short period and will reduce the product performance and service life.

●Operating environment

1. Do not use the product in locations that are subject to direct sunlight (ultraviolet rays); locations with high humidity and temperature, dust, salt, or iron powder.
2. Cover the unit when using it in locations where it might be subject to excessive dust, dripping water, dripping oil, etc.
3. Do not use the product in environments subject to external vibration or impact.

NOTE External vibrations or shocks may result in damage to component parts.

4. Avoid piping that is rigid, such as steel piping, if vibrations are transmitted. Use flexible tubes so that the product is not subject to the vibrations.

●Medium and operating environment

1. The temperature of the medium and the ambient environment must be within the range in the specifications.

NOTE Using the product in an environment that is outside the specified temperature or with media that is outside the specified temperature will cause the product's functions to stop after a short period and will reduce the product performance and service life.

2. Do not use media in the product or use the product in an environment that includes corrosive fluids such as organic solvents, phosphate ester type hydraulic oil, sulfur dioxide, chlorine gas, flon gas, ozone, acids, alkaline, etc.

NOTE Using the product in an environment or with media that is specified in the above item 2 will cause the product's functions to stop after a short period and will reduce the product performance and service life.

3. The bowl and the front cover of the pressure gauge of the filter regulator are polycarbonate. This product cannot be used in environments with the gases and fluids in item 2, nor thread-locking adhesive, leak detection fluid, hot water or where it may be exposed to them. This product also cannot be used in direct ultra-violet light. See page 16 for details.

Operation and maintenance inspections

●Method of use

Read the "Handling Instructions and Precautions" for each product for instructions on correct usage (Filter regulator and regulator page 8 to 12, residual pressure exhaust valve page 12 and page 13, module adapters page 14, pressure switch module page 14 and page 15, □30 [1.181 in] integrated pressure gauge page 15).

●Maintenance (maintenance inspection)

1. Performance and functions may decrease as the pneumatic equipment ages. Always conduct daily inspections of the pneumatic equipment, and confirm that all requisite system functions are satisfied, to prevent accidents from happening.
2. Read the "Handling Instructions and Precautions" for instructions on correctly doing maintenance and replacing maintenance parts (Filter regulator and regulators page 11 and page 12).
3. The product must be disassembled and reassembled to use the seal kit.

NOTE The product is no longer under warranty if it is disassembled or reassembled.



Filter regulator Regulator

Design and selection

●Pressure setting

1. A safety device must be installed for equipment/devices installed on the OUT port (secondary) side of the filter regulator or the regulator, because the equipment/device will be damaged or malfunction due to the pressure if the set pressure value is exceeded.
2. We recommend setting the pressure on the OUT port (secondary) side to less than 85% of the supply pressure setting on the IN port (primary) side.

NOTE If the pressure is set above 85%, the effect of the fluctuations in the IN port (primary) side pressure and flow rate are more prone to affect the OUT port (secondary) side pressure, and it becomes unstable.

3. It is not possible to install a valve on the IN port (primary) side of the internal pilot type filter regulator or regulator (such as models FRZ4□, FRZ5□, RZ4□, RZ5□) to repeatedly switch the pressure on the IN port (primary) side.

NOTE Changing the pressure of the IN port (primary) side may cause fluctuation in the OUT port (secondary) side set pressure.

4. The OUT port (secondary) side pressure may fluctuate if air is not consumed for a long time or if a sealed circuit or balance circuit is used. Contact your nearest Koganei sales office or overseas department.
5. Contact your nearest Koganei sales office or overseas department if you are using a circuit that needs highly precise pressure regulation.

●OUT Port (secondary) side pressure exhaust and vent hole

1. When the knob on the filter regulator or regulator is turned to reduce the OUT port (secondary) side pressure or when the OUT port (secondary) side pressure is higher than the set pressure and is exhausted, air is exhausted to the outside through the vent hole shown in the diagram.

NOTE There may be some vibration and noise caused by the exhaust.

2. Install a separate exhaust mechanism on the OUT port (secondary) side if an external force applied to an actuator or something on the OUT port (secondary) side of the filter regulator or regulator generates a sudden pressure increase.

NOTE The relief port is smaller than the diameter of the pipe and may not be able to adapt to the sudden rise in pressure of the OUT port (secondary) side.

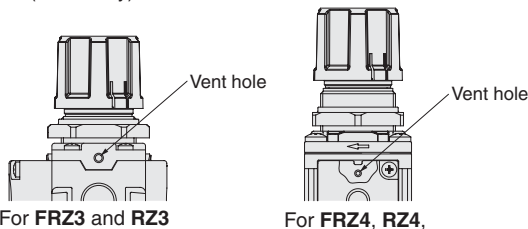

For FRZ3 and RZ3

For FRZ4, RZ4,
FRZ5, and RZ5

●Reverse flow from the OUT port (secondary) side to the IN port (primary) side (residual pressure exhaust)

1. Select the filter regulator or regulator (such as models FRZ32 and RZ32) with built in check mechanism specifications to release residual pressure on the IN port (primary) side to reduce pressure on the OUT port (secondary) side of the direct operation type filter regulator and regulator (such as models FRZ3□ and RZ3□).

NOTE Residual pressure processing on the OUT port (secondary) side with the standard specifications and low-pressure specifications may not be possible depending on the operating conditions.

2. The internal pilot type filter regulators and regulators (such as models FRZ4□, FRZ5□, RZ4□, RZ5□) use the relief port on the OUT port (secondary) side to reduce residual pressure when the IN port (primary) side pressure is released.

3. When using a built-in check mechanism specification filter regulator or regulator (such as models FRZ32 or RZ32) installed after the valve to adjust the thrust of the actuator, set the pressure on the OUT port (secondary) side of the built-in check mechanism specification filter regulator or regulator not to rise above the set pressure, which may be caused by the back pressure of the actuator (As a guideline, the difference in pressure for the push side and the pull side of the actuator should be 0.3 MPa [44 psi] or less.)

<Reference> Improving the system with a filter regulator or regulator with built-in check mechanism.

The filter regulator or regulator with built-in check mechanism releases pressure from the OUT port (secondary) side pressure to the IN port (primary) side as the main valve temporarily opens, because the pressure balance is disrupted when the built-in check valve is open as the IN port (primary) side pressure is lost. Due to easy change of the thrust of the pushing and pulling sides of the actuators, you can reduce air consumption by operating with low pressure on the side which does not need thrust.

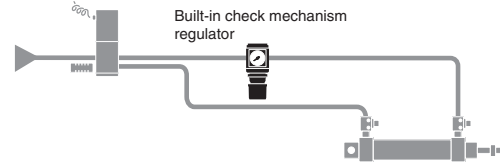

●Moisture and fluid removal

The filter regulator does not have a moisture and fluid removal function.

●Air consumption

1. The internal pilot type filter regulators and regulators (such as models FRZ4□, FRZ5□, RZ4□, RZ5□) consume air while regulating pressure on the OUT port (secondary) side.
2. Air consumption varies depending on the relationship of the IN port (primary) side pressure and the OUT port (secondary) side pressure.
3. The internal pilot type filter regulators and regulators (such as models FRZ4□, FRZ5□, RZ4□, RZ5□) reduce pressure by consuming air when the IN port (primary) side and OUT port (secondary) side are cut off and sealed.

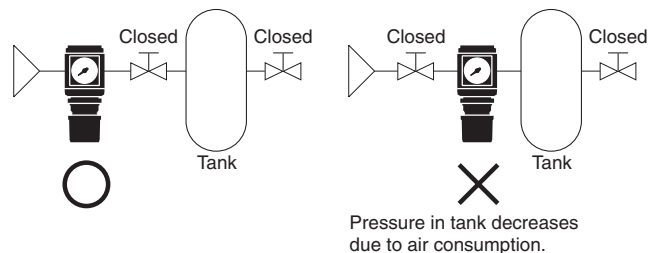

Pressure in tank decreases due to air consumption.

Mounting (installation) and piping

●Flow mark

The following diagram shows the relationship of the direction of flow of the media and the flow mark on the filter regulator or regulator.

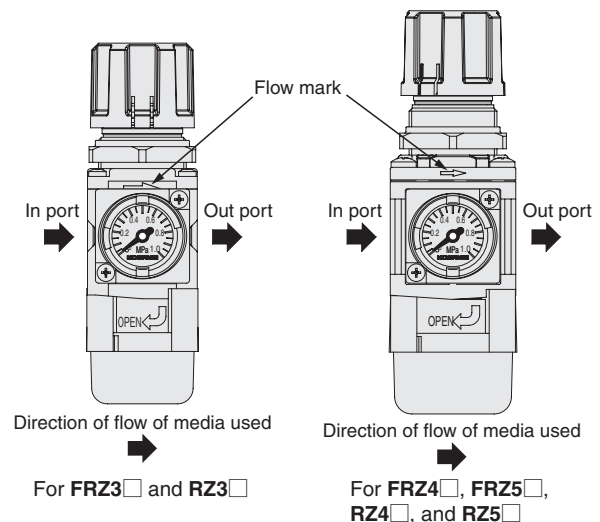

Direction of flow of media used

For FRZ3□ and RZ3□

Direction of flow of media used

For FRZ4□, FRZ5□,
RZ4□, and RZ5□

Handling instructions and precautions



Filter regulator Regulator

●Piping work

Connect pipes and fittings to the filter regulator and regulator IN ports and OUT ports so that the weight and torque of the pipes do not affect the product. When tightening the piping, grip the main unit and tighten it to the torque recommended on page 7.



Applying unnecessary force or impact to the knob, bowl assembly, or pressure gauge may damage component parts.

●Installing brackets

To install brackets, do it in the following order.

- ① Remove the knob.
(For how to remove the knob see "Removing the knob" on page 10.)
- ② Attach the bracket.
- ③ Screw on the mounting ring.



Tighten the mounting ring to less than 3.0 N·m [2.21 ft·lbf].

- ④ Attach the knob.
(For how to attach the knob see "Attaching the knob" on page 10.)

●Panel mount

1. All the mounting holes for the filter regulator and regulators for the panel mount installation are $\phi 28.5$ mm [1.122 in].
2. See the following table for the thickness of panels.

Model	FRZ3□	FRZ4□	FRZ5□
	RZ3□	RZ4□	RZ5□
Thickness	3 [0.118] or less	7 [0.276] or less	



Using a panel that is thicker than specified may make it impossible to secure the mounting ring or decrease the visibility of the yellow caution ring.

3. Use the following procedure to install with a panel mount.

- ① Remove the knob.
(For how to remove the knob see "Removing the knob" on page 10.)
- ② Attach the filter regulator or regulator to the panel.
- ③ Screw on the mounting ring.



Tighten the mounting ring to less than 3.0 N·m [2.21 ft·lbf].

- ④ Attach the knob.
(For how to attach the knob see "Attaching the knob" on page 10.)

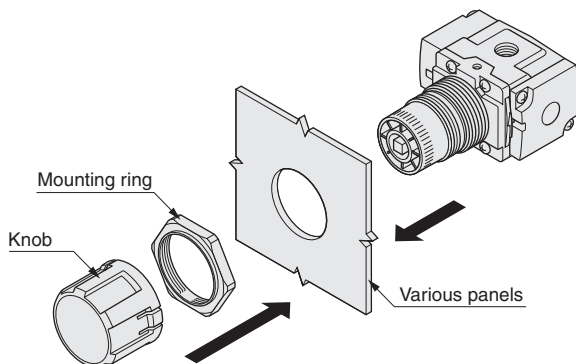

Operation and maintenance inspections

●Locking and releasing the knob

1. The Knobs on the filter regulators and regulators use a push lock mechanism.
Use the procedure shown below to lock and release the knob.

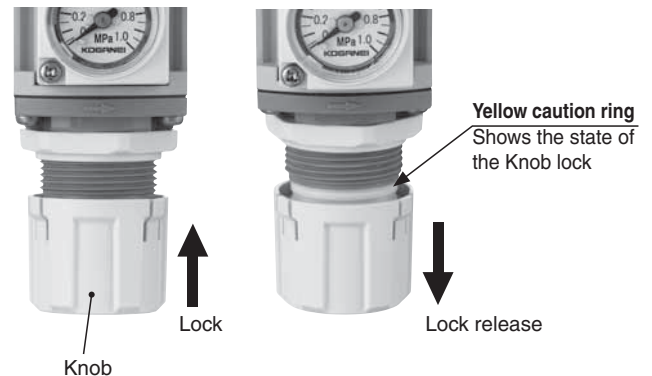

2. Always release the knob lock when regulating the pressure.



Turning the knob while it is locked may damage component parts.

3. Lock the knob after regulating the pressure.

●Pressure regulation

1. Pressure regulation is done as shown in the following diagram by turning the knob in the "+" direction to increase pressure and in the "-" direction, shown at the base of the knob, to reduce it.

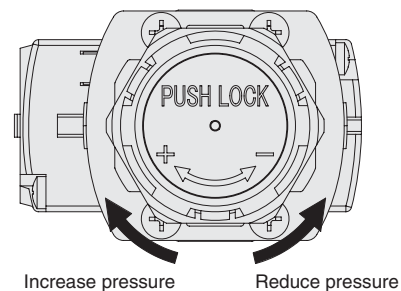

2. Start at a low pressure and match it to the desired set pressure when regulating the pressure. If you exceed the desired pressure, lower the pressure again and start from a low pressure again to set the pressure.



Starting from a high pressure to set the desired pressure causes unstable pressure on the OUT port (secondary) side.

3. Use a pressure gauge to check the pressure on the IN port (primary) side and OUT port (secondary) side while regulating the pressure.

4. It is possible to increase the set pressure to exceed the upper limit of the pressure setting range by turning the knob to the upper limit of the "+" side, but keep the regulated pressure within the pressure setting range.



Turning the knob farther than necessary may damage component parts.

●Removing the knob

Use the following procedure to remove the knob.

- ① Release the knob lock.
(For how to release the knob lock see "Locking and releasing the knob lock" on page 9.)
 - ② Turn the mounting ring counterclockwise (in the direction of the arrow in the diagram below).
- NOTE** Turn the mounting ring until it comes off the threads.
- ③ Pull the mounting ring over in the direction of the knob.
- NOTE** The release sleeve of the mounting ring must be pulled up until it spreads the hooks (3 places) on the knob.
- ④ Pull off the knob and the mounting ring together.

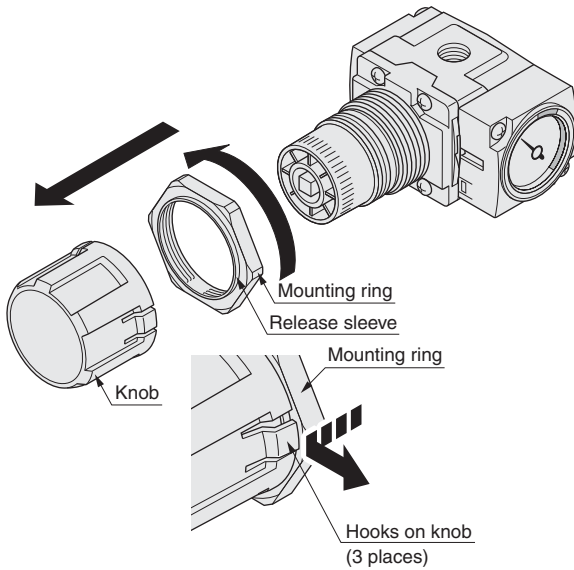

●Attaching the knob

1. Use the following procedure to attach the knob.

- ① Release the pressure of the IN port (primary) side to the atmosphere.
 - ② Screw on the mounting ring.
- NOTE** Installing the knob before screwing on the mounting ring makes it impossible to attach the mounting ring and makes the knob difficult to remove.
- ③ Press the knob in until the yellow caution ring is not visible.
- NOTE** Before pressing on the knob, align the square section of the adjusting assembly and the square indented portion of the base of the knob to make the knob easier to press on.

2. Attaching the knob while the filter regulator or regulator IN ports (primary) side pressure is being supplied, may cause a temporary rise in pressure on the OUT port (secondary) side pressure.

Before attaching the knob, always release pressure on the IN port (primary) side to the atmosphere, because a temporary increase in pressure on the OUT port (secondary) side may occur which may damage equipment or devices on the OUT port (secondary) side or cause a malfunction.

NOTE It may damage the equipment or devices or injure workers or operators.

3. If it is impossible to release the pressure on the IN port (primary) side to the atmosphere, the pressure on the OUT port (secondary) side will rise temporarily, check for any effect it may have had on equipment and devices that are installed after the filter regulator or regulators, and then attach the knob.

●Changing the □30 [1.181 in] integrated pressure gauge and pressure port plate

Use the following procedure to rotate the □30 [1.181 in] integrated pressure gauge 180°, and to change the □30 [1.181 in] integrated pressure gauge or pressure port plate.

- ① Remove the two small screws.
 - ② Remove any metal chips from the female thread hole with an air blower.
- NOTE** If there are any metal chips left, they may break the threads or get on the o-ring and cause an air leak.
- ③ Put the o-ring on the □30 [1.181 in] integrated pressure gauge or pressure port plate.
- NOTE** Not using an o-ring will result in air leaks.
- ④ Align the groove on the □30 [1.181 in] integrated pressure gauge or pressure port plate with the tongue on the main unit and attach it.
 - ⑤ Tighten the two mounting screws to 0.9 to 1.1 N·m [0.66 to 0.81 ft·lbf]

NOTE If torque exceeding the specifications is applied, the head of the screw or threads may be damaged and cause damage to component parts. Also, if torque below the specifications is used, the screw may come loose and cause an air leak.

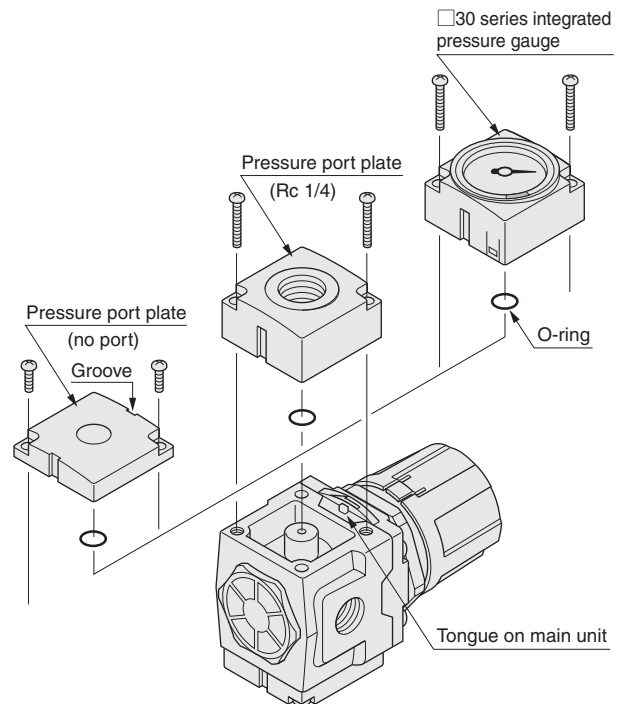

Handling instructions and precautions



Filter regulator Regulator

●Installing provided options

1. When installing the various types of pressure gauges, always apply the wrench on the square or hexagonal part of the piping connections.



Gripping the body of the various pressure gauges to tighten them may damage component parts.

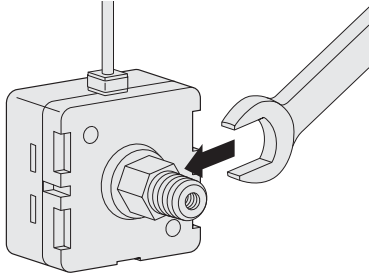

2. Use a tightening torque of 3.0 to 5.0 N·m [2.21 to 3.69 ft·lbf] if the various pressure gauges are mounted on the Rc1/4 port plate provided.



If torque exceeding the specifications is applied, it may damage component parts. Also, if torque below the specifications is used, the screw may come loose and cause an air leak.

3. There is a stopper on the Rc 1/4 female thread of the Rc1/4 pressure port plate.



Further tightening after the stopper has been reached may damage component parts.

●Replacing the pressure port plate, knob, and mounting ring

1. When replacing the pressure port plate, refer to "Replacing the □30 [1.181 in] integrated pressure gauge and pressure port plate" on page 10.
2. When replacing the knob and mounting ring, refer to "Removing the knob" and "Attaching the knob" on page 10.

●Replacing the seal kit, element, and bowl assembly

1. To replace the seal kit, element, and bowl assembly, remove the filter regulator or regulator and do the work on a work table.
2. The o-rings and other sealing materials (except for the diaphragm) of the filter regulator and regulator are coated with grease.
3. Contact your nearest Koganei sales office or overseas department if you are considering re-coating the o-rings and other parts.
Recommended grease: Lithium Soap based No. 2 or equivalent
4. Periodically replace the element in the filter regulator.



The service life of the element varies depending on the quality of air supplied to the IN port (primary) side. If there is a lot of foreign matter in the air supply to the IN port (primary) side, install a pre-filter on the IN port (primary) side or change the element more often. As a guideline, change the element after a year of use.

5. When replacing the seal kit, element, and bowl assembly, be careful not to lose component parts.
6. Refer to the diagram at right when replacing the seal kit, element, and bowl assembly.



Always assemble the component parts correctly.

Filter regulator bowl side

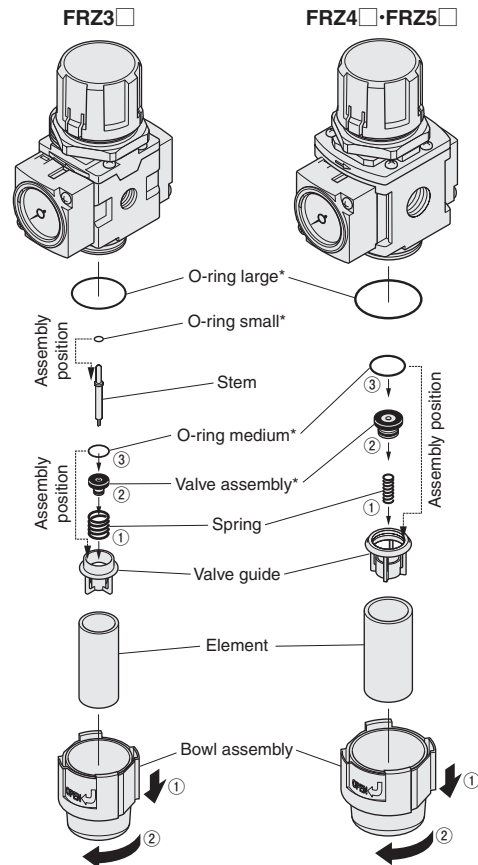

*Parts in seal kit.



The product is no longer under warranty if it is disassembled or reassembled.

Regulator and filter regulator knob side

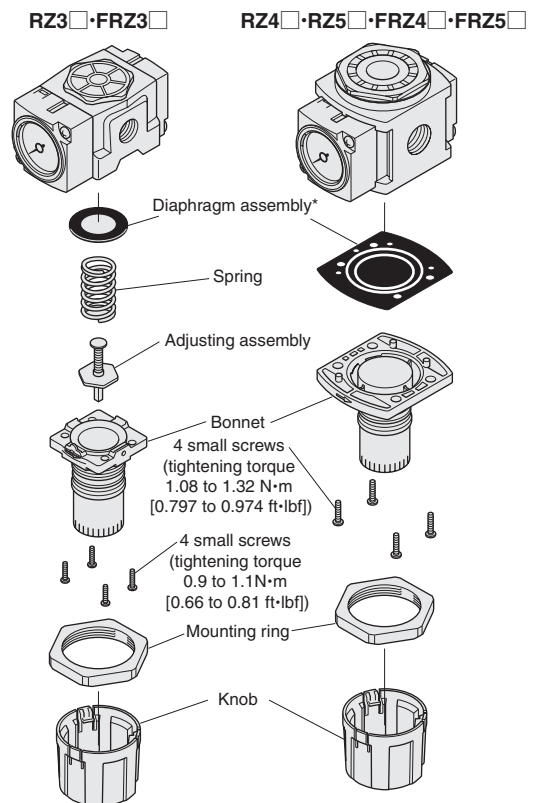

*Parts in seal kit.



The product is no longer under warranty if it is disassembled or reassembled.

Regulator plug side

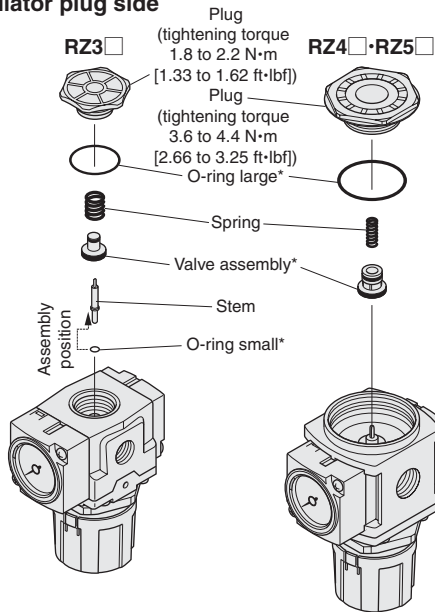

*Parts in seal kit.



The product is no longer under warranty if it is disassembled or reassembled.

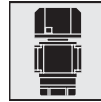

Residual pressure exhaust valve

Mounting (installation) and piping

●Flow mark

The following diagram shows the relationship of the direction of flow of the media and the flow mark on the residual pressure exhaust valve.

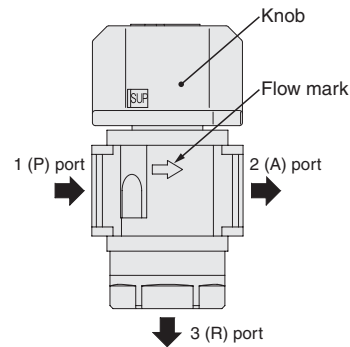

●Piping work

1. Connect pipes and fittings to the residual pressure exhaust valve 1 (P) port and 2 (A) port so that the weight and torque of the pipes do not affect the product. When tightening the piping, grip the main unit and tighten it to the torque recommended on page 7.



Applying unnecessary force or impact to the knob may damage component parts.

2. If a muffler or something is attached to the 3 (R) port of the residual exhaust valve, tighten it to 1.8 to 2.2 N·m [1.33 to 1.62 ft·lbf].



If torque exceeding the specifications is applied, it may damage component parts. Also, if torque below the specifications is used, the screw may come loose.

●Installing brackets

To install brackets, do it in the following order.

- ① Attach the bracket.
- ② Tighten the two mounting screws to 1.24 to 1.5 N·m [0.915 to 1.11 ft·lbf].



If torque exceeding the specifications is applied, the head of the screw or threads may be damaged and cause damage to component parts. Also, if torque below the specifications is used, the screw may come loose and cause an air leak.

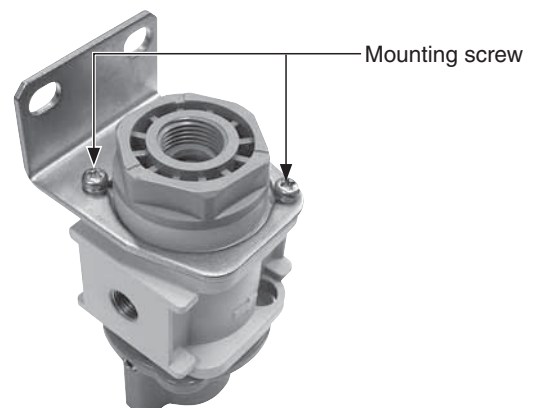

Mounting screw

Handling instructions and precautions

Operation and maintenance inspections

●State of air supply and exhaust

1. State of air supply is that air flows through from 1 (P) port (primary) side to 2 (A) port (secondary) side and is shut off at the 3 (R) port.
2. State of air exhaust is that air flows through from 2 (A) port (secondary) side to 3 (R) port and is shut off at 1 (P) port (primary) side.

●Switching the state of air supply and exhaust

1. To switch the air flow from supply to exhaust and vice versa, turn the knob 90° to "SUP", which is shown near the bottom of the knob, to supply air, or turn the knob 90° to "EXH" to exhaust air.

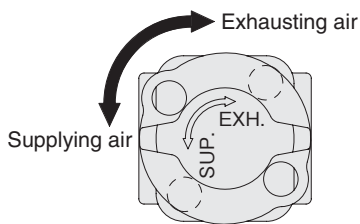

2. Check the window shown in the diagram below to see the state of the residual pressure exhaust valve. If "SUP" is showing, air is being supplied. If "EXH" is showing, air is being exhausted.

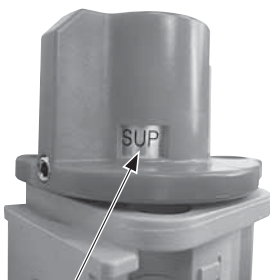

SUP : Supplying air



EXH : Exhausting air

3. Turn the knob slowly to gradually supply or exhaust air.



1(P) port (primary) side air cannot flow to 2 (A) port (secondary) side and 3 (R) port at the same time.

●Use as a 2-port valve

Plug the 3(R) port with an R3/8 plug to use the residual pressure exhaust valve as a 2-port valve

●Using the lock hole

1. The lock hole on the residual pressure exhaust valve is used to secure the air flow in a state of exhaust and to prevent changes to the state of the air supply.



Air cannot be supplied while the lock hole is used.

2. The diameter of the lock hole is ϕ 10 mm [0.394 in].
3. A lock must be supplied separately.



Lock (provided by the customer)

●Reducing exhaust noise

Attach a muffler to the 3 (R) port to reduce the exhaust noise.
Recommended muffler: Model KM-31



Module adapter

Mounting (installation) and piping

●Mounting (installation)

1. Use the various modules and adapters when combining the relevant FRZ series models and the relevant iB-Cyclone* models.
*See the back of the catalog.
2. Refer to "List of models" on page 39 regarding combinations of the relevant models, modules, and adapters.

NOTE The FRZ3□, RZ3□, and IBCY30 cannot be used together.

3. When assembling the products, check the flow marks on the products and assemble them so the media flows in the same direction. See the "Handling Instructions and Precautions" for each product regarding the relationship of the flow marks and direction of flow of the medium being used (filter regulators, regulators on page 8 and residual pressure exhaust valves on page 12).

4. Use the following procedure to assemble the products using the modules and adapters.

- ① Attach the o-rings to the connecting bracket (2 places)

NOTE Not using an o-ring will result in air leaks.

- ② Temporarily fix the products to the coupling plate.
- ③ Tighten a hexagon socket head screw to 0.9 to 1.1 N·m [0.66 to 0.81 ft·lbf].

NOTE If torque exceeding the specifications is applied, it may damage component parts. Also, if torque below the specifications is used, the screw may come loose.

<Example assembly>

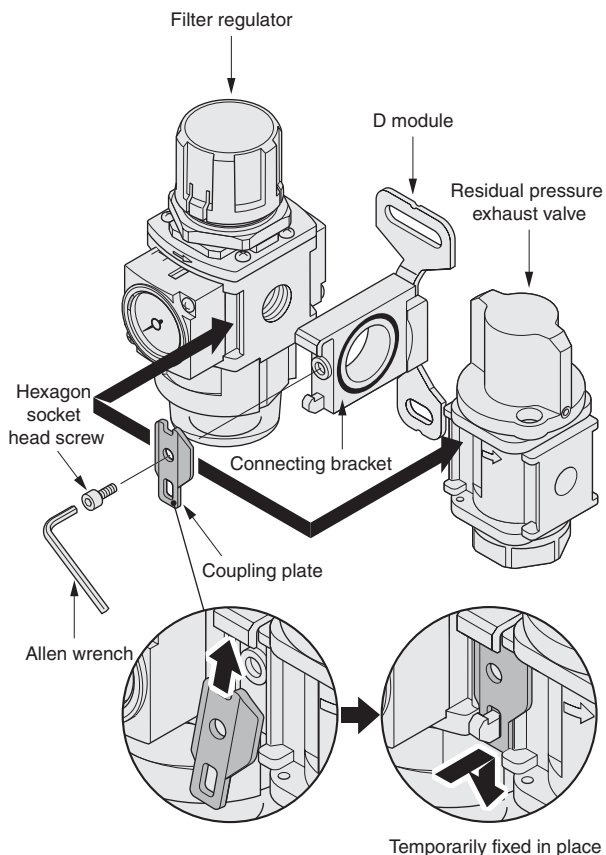

Pressure switch module

Mounting (installation) piping

●Mounting (installation)

1. The method to install the pressure switch modules is the same for the various modules and adapters. Refer to the "Handling Instructions and Precautions" for the modules and adapters.
2. Do not pull too hard on the wires or bend them too much. Also, when handling the products, carry them by the pressure switch side and do not apply too much force to the wires.
3. Be careful when handling the pressure switch modules, subjecting them to strong impact may cause damage or malfunction.

●Contact capacity

Use the specified load voltage and load current.

NOTE Using a load voltage or a load current that is outside the specifications may cause the contacts to fuse.

●Contact protection measure

The pressure switch module uses a reed sensor switch. Take the contact protection measures shown in the diagram below.

NOTE Contacts may fuse if measures to protect the contacts are not taken.

For connecting an inductive load (electromagnetic relay etc)

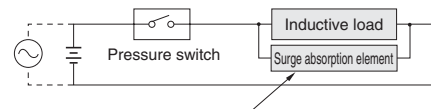

For DC ... Diode or CR, etc.

For AC ... CR etc.

Diode: Forward current should be more than the circuit current and the reverse current should be 10 times greater or more than the circuit voltage.

CR: C=0.01 to 0.1 μF

R=1 to 4 kΩ

If a capacitive surge occurs (if wire length is 10 m [32.8 ft])

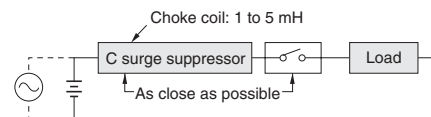

Medium and operating environment

●Operating environment

The pressure switch module uses a magnetically sensitive sensor switch.

Avoid large electric currents, such as locations where there is a strong magnetic field or near power lines.

NOTE Use in locations with strong external magnetic fields or near strong electric currents may cause the pressure switch module to malfunction.

Handling instructions and precautions

Operation and maintenance inspections

●Detection pressure scale

1. Use a detection pressure scale as a guideline.

NOTE Use a multi meter to confirm the output of the pressure switch module.

NOTE To accurately set the detected pressure, use a separate pressure gauge.

- Detection pressure scale is for the set value when the supplied pressure falls.
- Detection pressure scale is for the set value when the OFF signal is detected.

NOTE The ON signal is detected when the pressure exceeds the set pressure on the detection pressure scale by the response differential.

●Settings for the detection pressure

1. The detection pressure can be set to a value over the range of detection pressure, but always set it within the specified values.

NOTE Setting the pressure over the range of the detection pressure will damage component parts.

2. Use the following procedure to set the detection pressure.

- Turn the adjusting screw toward the "+" until the regulating indicator is aligned with the desired detection pressure on the scale.
- Supply pressure and use a multi meter to confirm that the signal indicates the desired pressure setting is detected.

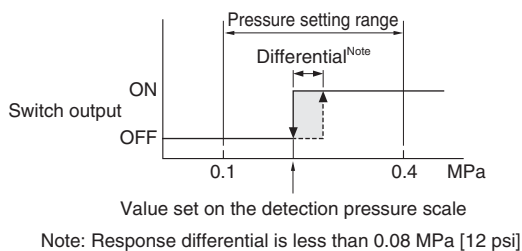
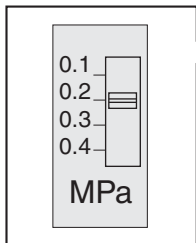
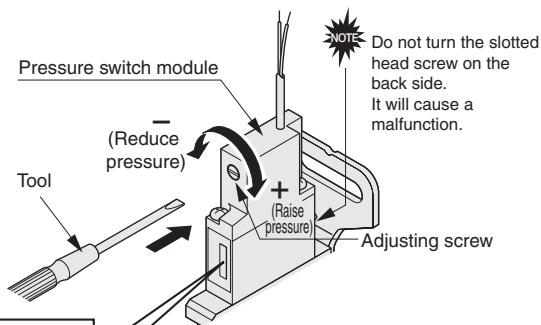

□30 series integrated pressure gauge

Mounting (installation) and piping

●Mounting (installation)

- Read the "Handling Instructions and Precautions" for the filter regulator and regulator when installing the □30 [1.181 in] integrated pressure gauge to the filter regulator or the regulator.
- Install the □30 [1.181 in] integrated pressure gauge to the filter regulator or regulator in the orientation shown in the diagram below.

NOTE It is possible to change the □30 [1.181 in] integrated pressure gauge installation to a 180° orientation, but it is not possible to change it to a 90° orientation.

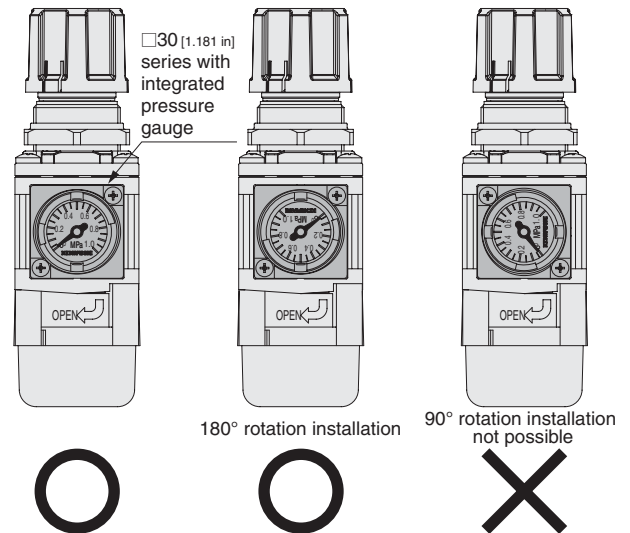

Medium and operating environment

●Surging, vibration, and shock

The □30 [1.181 in] integrated pressure gauge is a precision device. It cannot be used if the medium surges, or external vibration or shock is applied.

NOTE Surges in the media, external vibrations or shocks may result in damage to component parts.

Operation and maintenance inspections

●Adjusting the range of the set pressure

- Use the procedure below to adjust the range of the set pressure (the green portion).
 - Adjust the lower limit of the range of the set pressure by rotating the protrusions (2 places) clockwise with your hand.
 - Adjust the upper limit of the range of the set pressure by rotating the protrusions (2 places) clockwise with your hand.

NOTE Adjusting the range of the set pressure with a tool may damage component parts.

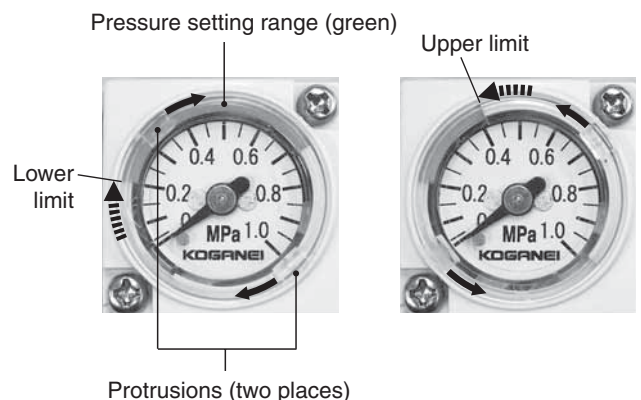

Reference material

● About the chemical resistance of polycarbonate

The chemicals in the following table degrade polycarbonate. Because of this, they may damage the bowl of the filter regulator or the front cover of the pressure gauge and cause an accident. The products cannot be used in locations where the chemicals in the following table are present in the compressed air, ambient air, or on surfaces. This does not mean that polycarbonate is chemically resistant to all chemicals not listed below.

Type	Classification	Chemical name	Application example
Inorganic compound	Acid	Chlorine, sulfuric acid, nitric acid, fluorine, phosphoric acid, chromic acid	Acid cleaning for metals, acid degreasing, and coating processing
	Alkali	Caustic soda, caustic potash, hydrated lime, ammonia water, sodium carbonate	Alkaline degreasing of metals
	Inorganic salt	Sodium sulfide, potassium nitrate, potassium dichromate, sodium nitrate	Dyes, rust inhibitor
Organic compounds	Aromatic hydrocarbons	Benzene, toluene, xylene, ethyl benzene, styrene	Paint thinner (Benzene, toluene, xylene)
	Chlorinated aliphatic hydrocarbons	Methyl chloride, ethylene chloride, methylene chloride, acetylene dichloride, chloroform, trichlene, tetrachloroethylene, carbon tetrachloride	Organic solvents for metal cleaning (trichlene, tetrachloroethylene, carbon tetrachloride)
	Chlorinated aromatic hydrocarbons	Chlorobenzene, dichlorobenzene, benzene hexachloride (BHC)	Agricultural chemicals
	Petroleum components	Solvent, naphtha, gasoline	Fuel
	Alcohol	Methyl alcohol, ethyl alcohol, cyclohexanol, benzyl alcohol	Anti-freezing agents
	Phenol	Carbolic acid, cresol, naphthol	Antiseptic solutions
	Ether	Methyl ether, methyl ethyl ether, ethyl ether	Brake fluid additive, detergent
	Ketones	Acetone, methyl ethyl ketone, cyclohexane, acetophenone	Cleaning solutions
	Carboxylic acid	Formic acid, acetic acid, butyl acid, acrylic acid, oxalic acid, phthalic acid	Dyes, aluminum processing solution (oxalic acid), paint medium (phthalic acid)
	Phthalic acid ester	Dimethyl phthalate (DMP), diethyl phthalate (DEP), dibutyl phthalate (DBP), dioctyl phthalate (DOP)	Lubricants, synthetic hydraulic fluids, corrosion resistant additives, synthetic resin plasticizer
	Oxyacid	Glycolic acid, lactic acid, malic acid, citric acid, tartaric acid	Food preservatives, acidulant
	Nitro compounds	Nitromethane, nitroethane, nitroethylene, nitrobenzene	Paint solvent, explosives
	Aminos	Methylamine, dioctylamine, ethylamine, aniline, acetanilide	Brake fluid additive
	Nitrile	Acetonitrile, acrylonitrile, benzonitrile	Nitrile rubber materials

Limited Warranty

KOGANEI CORP. warrants its products to be free from defects in material and workmanship subject to the following provisions.

Warranty Period The warranty period is 180 days from the date of delivery.

Koganei Responsibility If a defect in material or workmanship is found during the warranty period, KOGANEI CORP. will replace any part proved defective under normal use free of charge and will provide the service necessary to replace such a part.

Limitations

- This warranty is in lieu of all other warranties, expressed or implied, and is limited to the original cost of the product and shall not include any transportation fee, the cost of installation or any liability for direct, indirect or consequential damage or delay resulting from the defects.

- KOGANEI CORP. shall in no way be liable or responsible for injuries or damage to persons or property arising out of the use or operation of the manufacturer's product.

- This warranty shall be void if the engineered safety devices are removed, made inoperative or not periodically checked for proper functioning.

- Any operation beyond the rated capacity, any improper use or application, or any improper installation of the product, or any substitution upon it with parts not furnished or approved by KOGANEI CORP., shall void this warranty.

- This warranty covers only such items supplied by KOGANEI CORP. The products of other manufacturers are covered only by such warranties made by those original manufacturers, even though such items may have been included as the components.

The specifications are subject to change without notice.

Related catalogs



Introducing the iB-Cyclone, a high-speed cyclone type moisture separator that incorporates the best of centrifugal separation know-how.

iB-Cyclone
Catalog No. BK-E0005

URL <http://www.koganei.co.jp>

E-mail: overseas@koganei.co.jp



KOGANEI CORPORATION

OVERSEAS DEPARTMENT

3-11-28, Midori-cho, Koganei City, Tokyo 184-8533, Japan
Tel: 81-42-383-7271 Fax: 81-42-383-7276

KOGANEI INTERNATIONAL AMERICA, INC.

39300 Civic Center Dr., Suite 280, Fremont, CA 94538, U.S.A.
Tel: 1-510-744-1626 Fax: 1-510-744-1676

SHANGHAI KOGANEI INTERNATIONAL TRADING CORPORATION

Room 2606-2607, Tongda Venture Building No.1, Lane 600, Tianshan Road,
Shanghai, 200051, China
Tel: 86-21-6145-7313 Fax: 86-21-6145-7323

KOGANEI KOREA CO., LTD.

KT&G Cosmo Bldg., 3F, 40-13, Maesanno 2-ga, Paldal-gu, Suwon-si, Gyeonggi-do,
442-847, Korea
Tel: 82-31-246-0414 Fax: 82-31-246-0415

KOGANEI-PORNCHAI CO., LTD.

89/174 Moo 3, Vibhavadee Rangsit Road, Talad Bangkhen, Laksi, Bangkok,
10210, Thailand
Tel: 66-2551-4025 Fax: 66-2551-4015

KOGANEI ASIA PTE. LTD.

12 Arumugam road #03-12, Lion Building B, 409958, Singapore
Tel: 65-6293-4512 Fax: 65-6293-4513



FRZ Series and iB-Cyclone can be used in combination. (Except for FRZ3□, and RZ3□) Contact the sales department at Koganei sales office or Koganei overseas department for more information.