

SPEED CONTROLLERS TSC SERIES

M5×0.8, With Clamp Fitting

- Compact and lightweight, optimum for Pen Cylinders and Jig Cylinders.
- Wide variation of products allows mounting in any direction.
- Straight type and L type offer a choice of piping directions.

Symbol

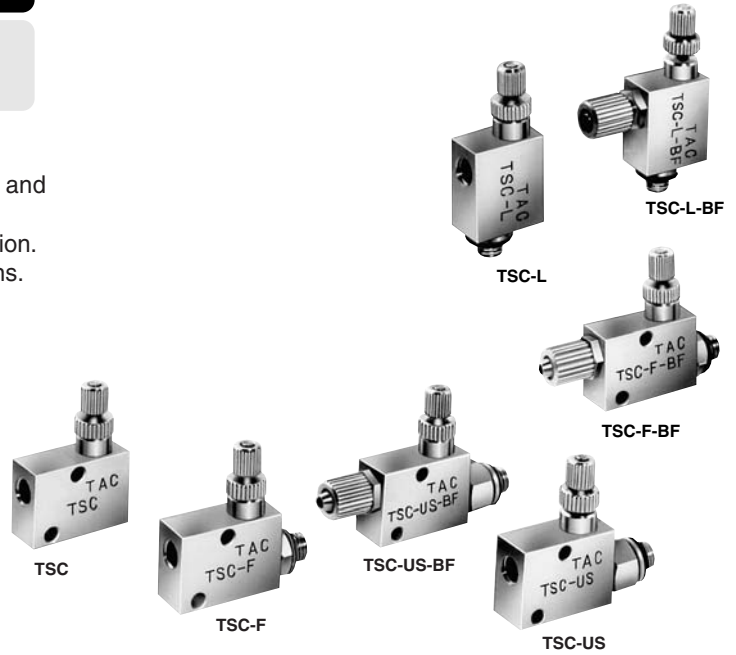
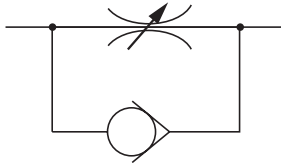

Specifications

Item	Model	TSC	TSC-F	TSC-F-BF	TSC-US	TSC-US-BF	TSC-L	TSC-L-BF
Piping type and port size	Controlled flow P	Female thread M5×0.8	Male thread M5×0.8		Union male thread M5×0.8		Male thread M5×0.8	
	Controlled flow A	Female thread M5×0.8		For urethane tube φ 4×2.5 Clamp fitting	Female thread M5×0.8	For urethane tube φ 4×2.5 Clamp fitting	Female thread M5×0.8	For urethane tube φ 4×2.5 Clamp fitting
Media		Air						
Operating pressure range	MPa [psi.]	0~0.9 [0~131]						
Proof pressure	MPa [psi.]	1.32 [191]						
Cracking pressure	MPa [psi.]	0.05 [7.3]						
Operating temperature range	°C [°F]	5~60 [41~140]						
Mass	g [oz.]	16 [0.56]	18 [0.63]	20.5 [0.72]	19 [0.67]	21.5 [0.76]	15 [0.53]	17 [0.60]

Order Codes

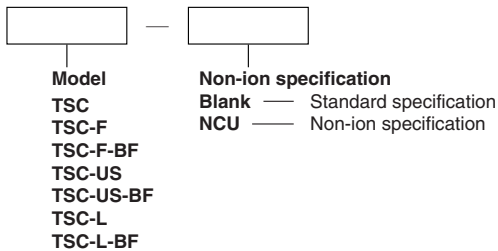

Inner Construction and Major Parts

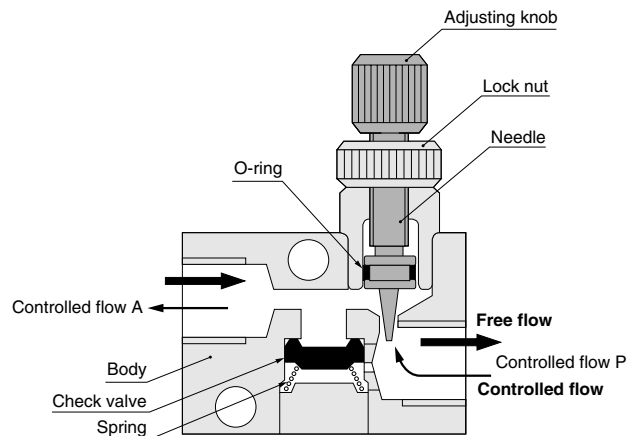

Major Parts and Materials

Parts	Materials
Body	Brass (nickel plated)
Needle	Stainless steel
Lock nut	Brass (nickel plated)
Check valve	Synthetic rubber (NBR)
O-ring	
Adjusting knob	Brass (nickel plated)

Dimensions (mm)



● Straight type ● TSC

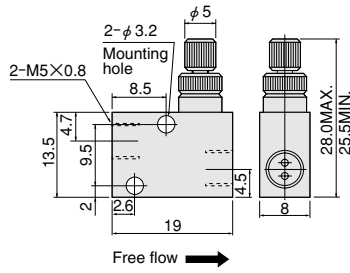

● TSC-F

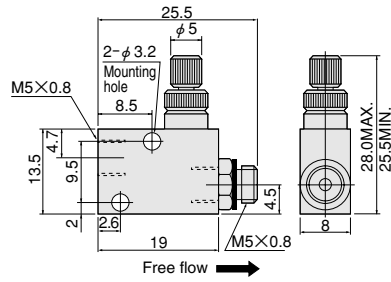

● TSC-F-BF

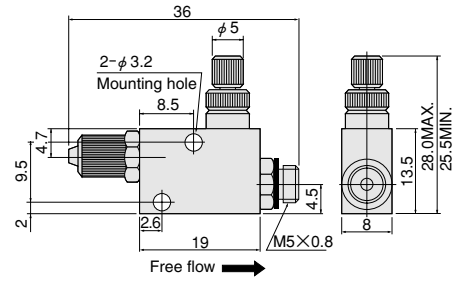

● TSC-US

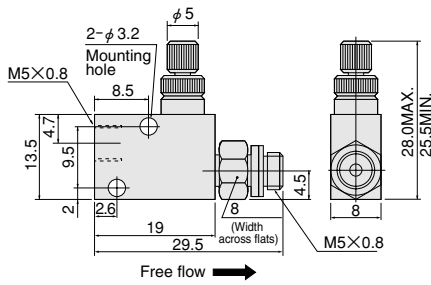

● TSC-US-BF

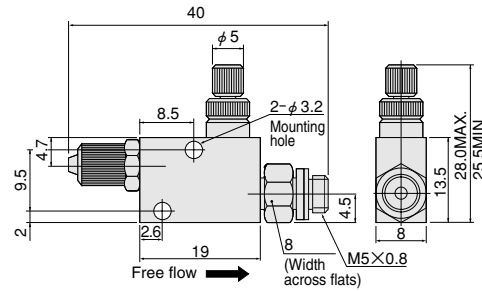

● L type ● TSC-L

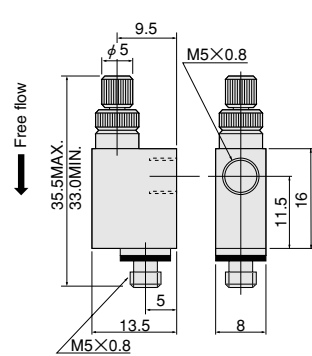

● TSC-L-BF

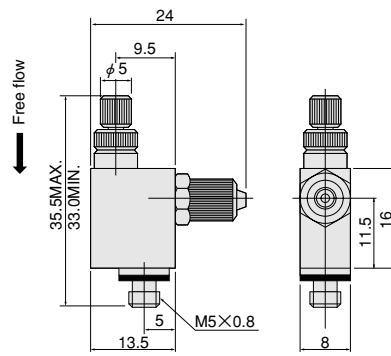

Flow Rate Characteristics

● Controlled flow

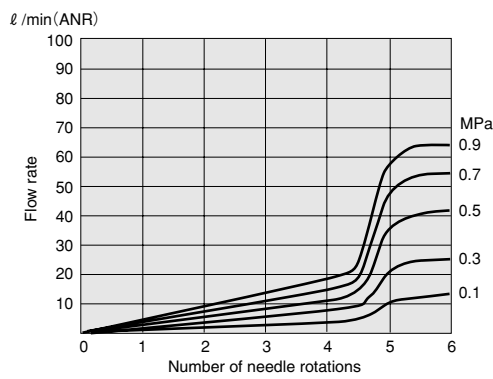

1MPa = 145psi. 1 l/min = 0.0353ft³/min.

● Free flow

