

AIR BLEEDERS

- Remove air bubbles accumulating inside the piping of a low pressure hydraulic circuit, to enable stable speed control.
- The transparent body allows quick visual confirmation of air bubble occurrence.
- Push-type air bleeder button supports simple handling.
- The bleed port is equipped with a fitting, to avoid contamination of surrounding areas.

Symbol

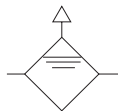

Specifications

| Item | Model | AHB150-□-□ |
|-----------------------------|-------------|----------------------|
| Maximum operating pressure | MPa [psi.] | 0.9 [131] |
| Proof pressure | MPa [psi.] | 1.3 [189] |
| Operating temperature range | °C [°F] | 5~60 [41~140] |
| Mass | g [oz.] | 160 [5.64] |
| Materials | Body | Polycarbonate |
| | Piping part | Aluminum die-casting |

Order Codes

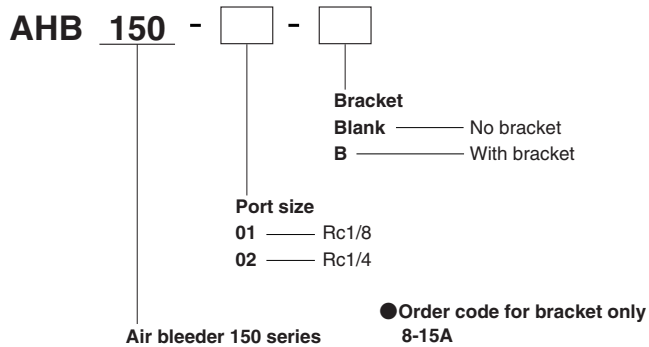

Inner Construction and Major Parts

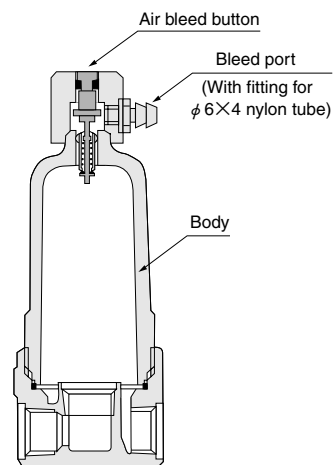

Dimensions (mm)

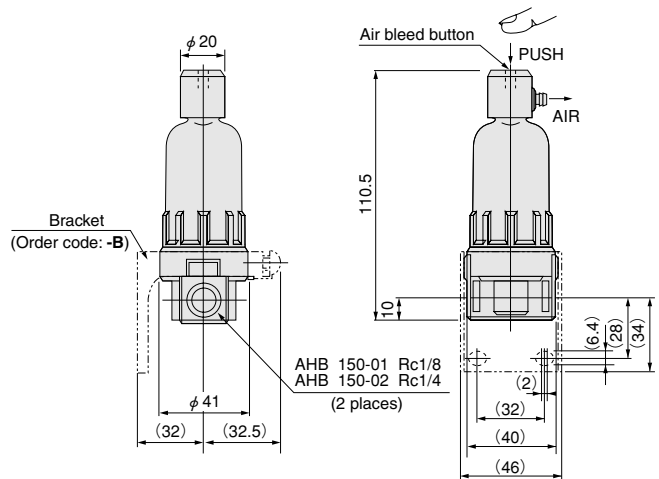

Handling Instructions and Precautions

● Mounting

- Mount the air bleeder in a vertical position.
- For the most efficient air bleed operation, mount the unit either directly onto the cylinder, or at the highest position in the piping system.
- If the piping system has an area where air bubbles tend to accumulate, mount the unit at that location.

● Bleeding the air

- Whenever air pressure is applied to the converter, press the air bleed button to bleed out the air.

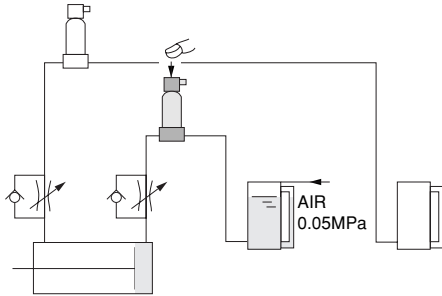

- For the oil supplied to the converter, always use the recommended hydraulic oil. For recommended hydraulic oil, see p.554.
- The air bleeder body is made of polycarbonate. Avoid use in locations where the ambient atmosphere contains organic solvents, etc.