

Vacuum Valve Units

- **MV180 Series:** Large flow rate type with effective area of 4 mm² [Cv = 0.22]
MV030, MV090 Series: Compact type with effective area of 0.55 mm² [Cv = 0.0306] and 2 mm² [Cv = 0.11]
- Lineup of a wide range of applications enables selection suited to the transfer workpiece on the production line in factory.

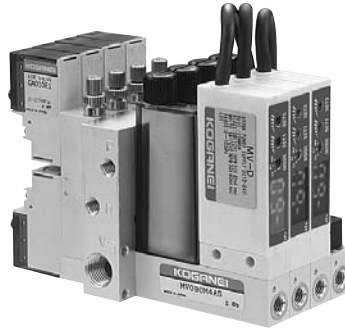

A type manifold, two to eight units
Without filter and vacuum switch



AS type manifold, two to eight units
With filter and vacuum switch

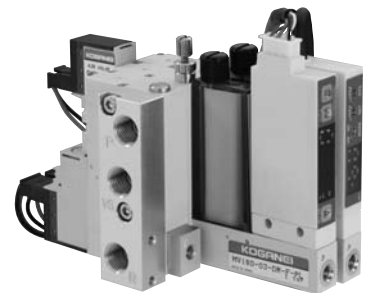

A type manifold, two to eight units
Some units with filter and vacuum switch and some without (only for MV180 series)



Single Unit
With filter and vacuum switch



Single Unit
Without filter and vacuum switch

- Electronic vacuum switch equipped with LED display for easy operations check



The Koganei Vacuum Valve Unit Is...

A solenoid vacuum valve with additional functions (vacuum break, hold detection, etc.) required for vacuum pad using transfer system control. (As there is no vacuum generation function, be sure to also connect a vacuum pump, etc.)

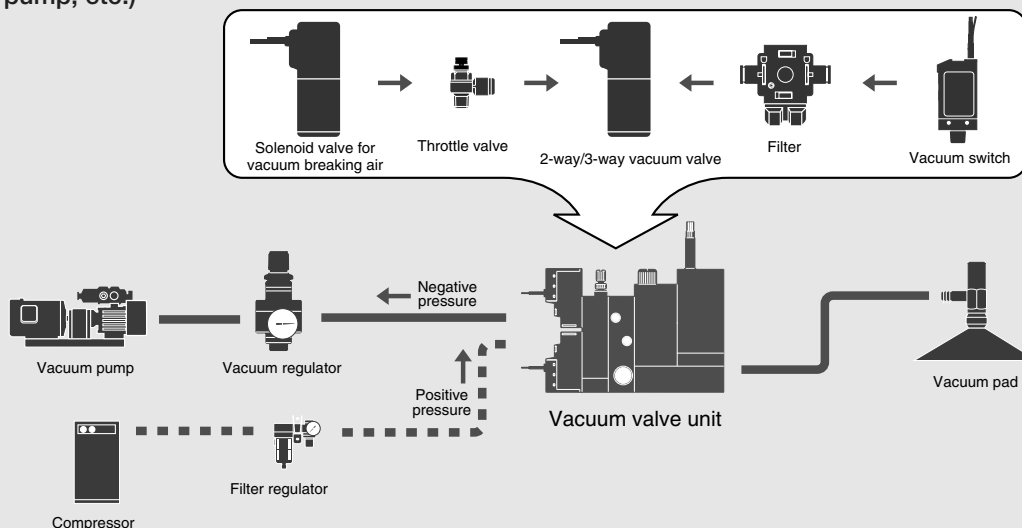

● High space efficiency

The manifold is a fully equipped (with filter and electronic vacuum switch) thin-type design in 12.5 mm [0.492 in.] (MV180 series) and 10.2 mm [0.402 in.] (MV030, 090 series) sizes.

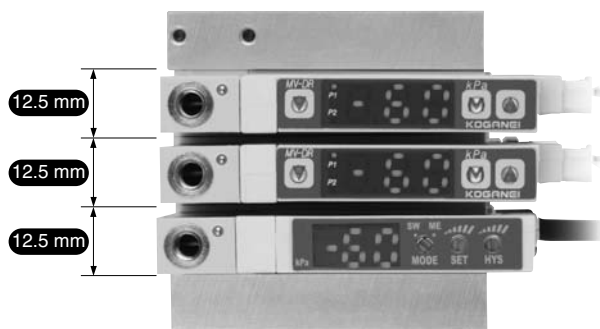

MV180 series



MV030, 090 series

NEW

Option

Pressure sensor (-EA, -ER)

Use in combination with the multi-channel pressure sensor controller to perform checks and adjustments from a remote location.

Multi-channel pressure sensor controller

PSU-□



For details of the multi-channel pressure sensor controller, see p.780.

Vacuum breaking air separate port type (MV180-0□B)^{Note}

-01B, -02B, -03B, -04B types

In addition to the V (vacuum) port, the -0※B type is also equipped with a D (vacuum break) port.

For example, configuration of an air pressure circuit as shown below can obtain vacuum breaking air that is clean. (F1: Recommended filter PLF050)

Note: Option for MV180 series only.

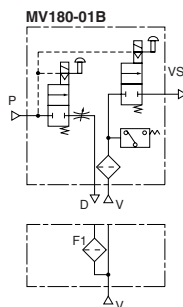

For details, see p.628.

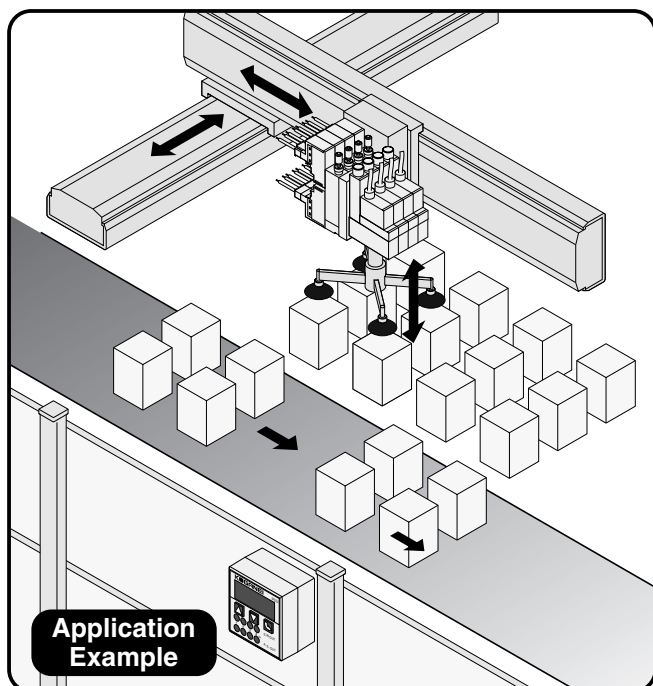

Application Example

Safety Precautions (Vacuum Valve Units)

The following is safety precautions to Vacuum Valve Units. For other safety precautions, be sure to read the precautions on p.49.

Caution

- Oil from compressors (with the exception of oil-free compressors) severely affects products performance, and can even cause shutdown of products performance. When in operation, always install a mist filter to eliminate the oil on the upstream side of pneumatic equipment.

Attention

- The valve is not capable of zero air leaks. For applications where pressure (including vacuum) in the pressure vessel must be maintained, always consider the required volume and holding time when designing systems.

Handling Instructions and Precautions



General precautions

Mounting

1. While any mounting direction is acceptable, avoid directly subjecting the body to strong shocks or vibrations.
2. Avoid use of the Vacuum Valve Unit in the following types of locations and environments, because of the possibility of an equipment breakdown. If you must use it in such locations, always use a cover or take other protective measures.
 - Locations where the Vacuum Valve Unit is directly subject to dripping water or dripping oil, etc.
 - Environments where the vacuum valve unit is subjected to condensation.
 - Locations where the vacuum valve unit is directly subjected to chips or dust.
3. Always thoroughly blow off (use compressed air) or air blowing the tubing before piping to vacuum valve unit. Entering chips, sealing tape, rust, etc., generated during plumbing could result in air leaks or other defective operation.
4. If mounting the vacuum valve unit inside a control panel or in other locations where longer energizing period is required, provide adequate ventilation etc. for radiating heat.
5. Use one vacuum pad for each Vacuum Valve Unit (or each station in the manifold). Use of two or more pads could result in picking errors, and longer time required to reach the set vacuum.
6. For Vacuum Valve Units with filters, replace the filters at periodic intervals (order code: MV-F).
7. Do not apply pressure to the vacuum switch in excess of its maximum pressure range.
8. Use a mounting base (MV-21) when mounting the vacuum valve unit.
9. In the -05 and -06 types, intrusion of outside air through the R port can result in vacuum break, and cause the picked items to fall under their own weight. Always install a filter or muffler to the R port.
10. In the -01 and -02 vacuum hold types, when the vacuum break flow rate is very large and the orifice on the vacuum port side is small, the gasket is designed to pop off, to prevent damage to the filter cover. If the gasket has popped off, throttle down the vacuum break flow rate, restore the gasket to its correct position, and reset.

Media

1. Use air for the media. For the use of any other media, consult us.
2. Use clean air that does not contain deteriorated compressor oil or other contaminants. Install an air filter (with filtration of a minimum $40 \mu\text{m}$) close to the vacuum valve unit to eliminate any airline condensation or dust. Moreover, clean the air filter at regular intervals.

Atmosphere

The product cannot be used when the media or the ambient atmosphere contains any of the substances listed below. Organic solvents, phosphate ester type hydraulic oil, sulphur dioxide, chlorine gas, or acids, etc.

Wiring

After completion of wiring operations, check that no miswiring has been made.

Handling Instructions and Precautions

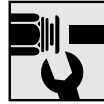

Piping

1. Connect air supply to the supply port (P), the vacuum source to the vacuum supply port (VS), and the vacuum pad, etc., to the vacuum port (V).
2. Use a fitting that does not reduce its inside diameter of air piping. A small inner diameter restricts flow rate and reduces the vacuum level, resulting in reduced pick up performance by the vacuum pad.
3. Avoid using coil tubes and other spiraled piping. Also avoid the use of elbows, etc., between the vacuum valve unit and the vacuum pad, and try to make the piping as straight as possible.
4. When a large number of vacuum valve units are simultaneously operating on the same manifold, or when the vacuum valve unit operates at a high frequency, connect vacuum sources to VS ports at both sides.
5. Calculate the maximum intake flow rate for the vacuum pump, and select it with a flow rate that leaves plenty of margin.

Filter element

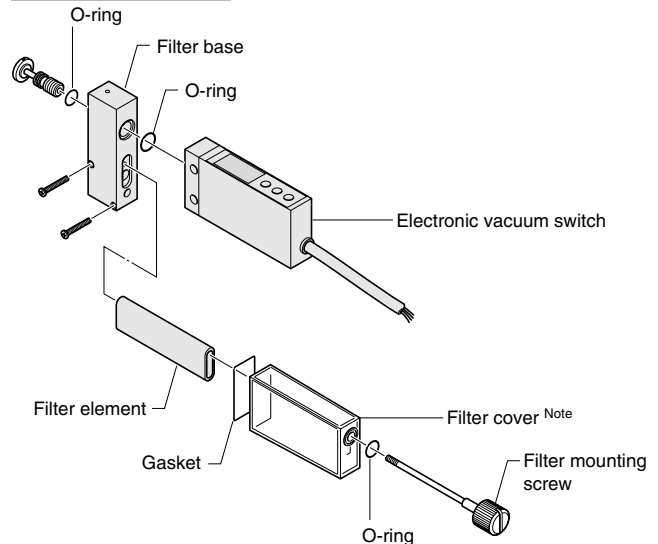

Note : The filter cover is made of polycarbonate.

Also, do not use it in atmospheres subject to organic solvents, etc.

1. To replace the filter, loosen the filter mounting screw, remove the filter cover, and pull out the filter element. If the filter mounting screw is difficult to turn because of its location on a manifold, use a flat blade screwdriver to loosen it.
2. After the filter element has been replaced, check to see whether the gasket is in a correct position, and then assemble the unit using the filter mounting screw. If the filter mounting screw is difficult to turn because of its location on a manifold, use a flat blade screwdriver to tighten it. The tightening torque should be $0.196 \text{ N}\cdot\text{m}$ [$1.73 \text{ in}\cdot\text{lbf}$].

Mounting base

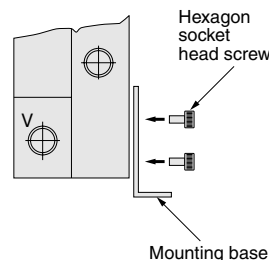

Use the hexagon socket head screw provided to mount the mounting base into the vacuum valve unit's mounting thread. The tightening torque for the M2.6 screw should be $0.32 \text{ N}\cdot\text{m}$ [$2.83 \text{ in}\cdot\text{lbf}$], and for the M3 screw, $0.589 \text{ N}\cdot\text{m}$ [$5.21 \text{ in}\cdot\text{lbf}$].



Solenoid

Internal circuit

●GA010E1(DC12V, DC24V) Solenoid with LED indicator (surge suppression)

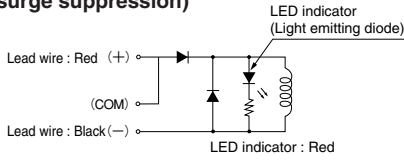

●GAV010HE1(DC12V, DC24V) ●GA010LE1-2W(DC24V) Solenoid with LED indicator (surge suppression)

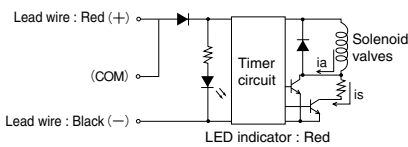

ia : Starting current, is : Steady current

Operation principles of GAV010HE1 and GA010LE1-2W

The GAV010HE1 and GA010LE1-2W uses a timer circuit, as shown above, that achieves power savings by switching to holding operations mode after a certain period of time to operate at about 1/3 of the starting power consumption.

●Power waveform GAV010HE1

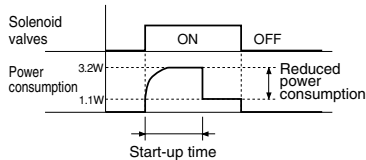

	Start-up time (standard time)
DC12V	48 ms
DC24V	27 ms

GA010LE1-2W

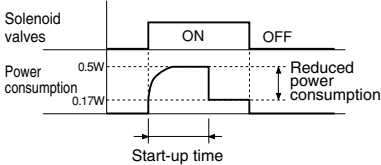

	Start-up time (standard time)
DC24V	48 ms

- Cautions:**
- Do not apply megger between the lead wires.
 - While there is no danger with a DC solenoid of a short circuit by the wrong polarity, the valve will not operate.
 - Leakage current inside the circuit could result in failure of the solenoid valve not to return or in other erratic operation.
Always use within the range of the allowable leakage current. If circuit conditions, etc., cause the current leakage to exceed the maximum allowable leakage current, consult us.
 - The GAV010HE1 and GA010LE1-2W will not operate if the power supply voltage is increased slowly. Always apply the appropriate voltage.



Manual override

Locking type

To lock the manual override, use a small screwdriver to push down on the manual override all the way and turn it clockwise. When locked, turning the manual override in the counterclockwise direction releases a spring on the manual override, returns it to the original position, and releases the lock. When the manual override is not turned, this type acts just like the non-lock type. The valve will enter into the energized position as long as the manual override is pushed down, and it returns to the rest position upon release.

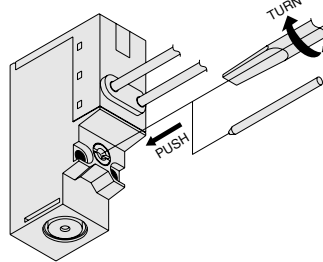

- Cautions:**
- Always release the lock of the locking type before commencing normal operation.
 - Do not attempt to operate the manual override with a pin or other object having an extremely fine tip. It could damage the manual override button.

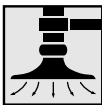

Vacuum break

Adjustment of vacuum breaking flow rate

Rotate the adjusting needle for vacuum breaking flow (not available in -05 and -06) in the clockwise direction to reduce the breaking flow rate, and in the counterclockwise direction to increase the breaking flow rate. The tightening torque for the lock nut should not exceed 0.196 N·cm [1.73 in·lbf].

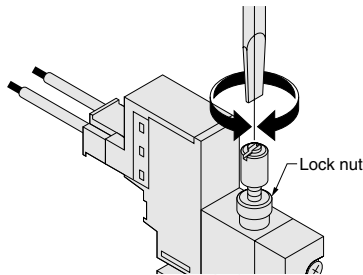

Precautions for using the manifold

In the manifold mounting -03 and -04 type valves, simultaneous use of multiple large-volume vacuum breaking air can lead to the possibility of positive pressure flows out from the V ports on the closed stations of the vacuum breaking valve and vacuum supply valve. There is no such effect on stations in the picking up operation, nor is there any effect on manifold mounting the -01 and -02 type valves. The -03 and -04 types have constructions that improve the vacuum breaking tact time in processes for the picking and transferring of small hard to lift items where high-pressure, high-volume vacuum breaking air cannot be used. For this reason, the -01 and -02 types are recommended for use with high-pressure, high-volume vacuum break operations.



Plug connector

Attaching and removing plug connector

Use fingers to insert the connector into the pin, push it in until the lever claw latches onto the protruded section of the connector housing, and complete the connection. To remove the connector, squeeze the lever along with the connector, lift the lever claw up from the protruded section of the connector housing, and pull it out.

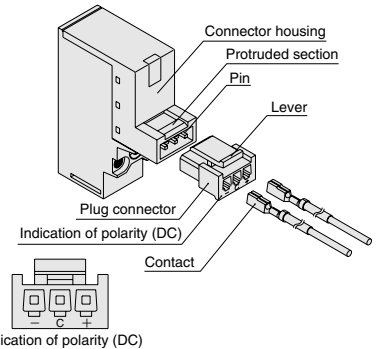

Crimping of connecting lead wire and contact

To crimp lead wires into contacts, strip off 4 mm [0.16 in.] of the insulation from the end of the lead wire, insert it into the contact, and crimp it. Be sure to avoid catching the insulation on the exposed wire crimping section.

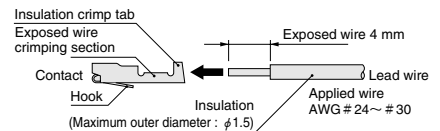

Attaching and removing contact and connector

Insert the contact with lead wire into a plug connector hole until the contact hook latches on the connector and is secured to the plug connector. Confirm that the lead wire cannot be easily pulled out. To remove it, insert a tool with a fine tip (such as a small screwdriver) into the rectangular hole on the side of the plug connector to push up the hook, and then pull out the lead wire.

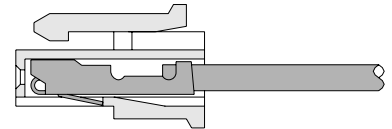

- Cautions:**
- Do not pull hard on the lead wire. It could result in defective contacts, breaking of wire, etc.
 - If the pin is bent, use a small screwdriver, etc., to gently straighten out the pin, and then complete the connection to the plug connector.
 - For crimping of connecting lead wire and contact, always use a dedicated crimping tool.
Contact: Model 706312-2MK
Manufactured by Sumiko Tech, Inc.
Crimping tool: Model F1 (for 706312-2MK)
Manufactured by Sumiko Tech, Inc.

Handling Instructions and Precautions



Electronic Vacuum Switch

Setting

●-D (MV-D) (Not available for MV180) Switch 2-output (fixed hysteresis) type

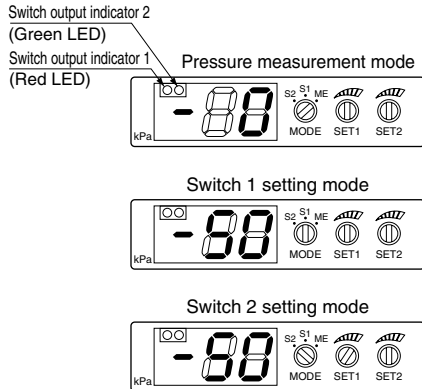

- 1) Set the display mode switch (MODE) to S1.
- 2) Rotate the pressure setting trimmer 1 (SET1) and set switch 1's operating pressure.
- 3) Set the display mode switch (MODE) to S2.
- 4) Rotate the pressure setting trimmer 2 (SET2) and set switch 2's operating pressure.
- 5) Return the display mode switch (MODE) to ME.

●-DA (MV-DA) Switch 1-output (variable hysteresis) + analog output type

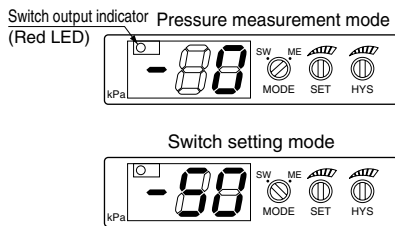

- 1) Set the display mode switch (MODE) to SW.
- 2) Rotate the pressure setting trimmer 1 (SET) and set the switch's operating pressure.
- 3) Rotate the hysteresis setting trimmer (HYS) and set the hysteresis.
- 4) Return the display mode switch (MODE) to ME.

- Cautions:**
1. For high-precision settings, repeatedly apply variable pressure on the unit to check switching operation at the desired pressure.
 2. The switch setting range (variable range of the setting trimmer) is not aligned with the pressure display range. While the display range is 0-99, there can be an FS setting of several percent over the range, and the actual figure is below 0 or above 99 in the case.
 3. Avoid excessive force when handling the display switch and trimmer for setting pressure. Their rotation torque should not exceed 0.025 N·m [0.221 in·lbf].

●-DR (MV-DR) Switch 2-output (variable hysteresis) type

(1) Operation panel names

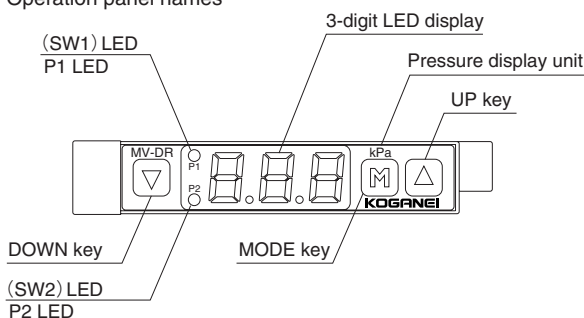

(2) Error displays

- When an error occurs, take the following actions.

Error display	
Description	Overload current is flowing. (SW1 and/or SW2 LEDs detecting the overload are blinking.)
Action	Shut off the power, and check the load status.
Error display	
Description	Pressure applied during zero-point adjustment.
Action	Press the key to cancel , reset the applied pressure to the pressure port to atmospheric pressure, and perform zero-point adjustment again.
Error display	
Description	Applied pressure exceeds upper limit of the display pressure range.
Action	Check the applied pressure.

(3) Function

■ Startup display check

When the power is switched on, all displays momentarily light up once.

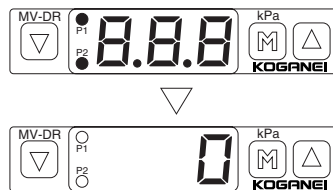

In the operation mode, starts up the pressure detection process.

■ Non-display mode (low radiating heat)

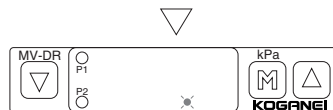

In non-display mode, a reduction in radiating heat is expected.

- Only if the 3-digit LED was set to non-display in the initial setting, the 3-digit LED will go into non-display mode during operation whenever key operation fails to occur for a continuous period of about 10 seconds.

- Cautions:**
1. The decimal point in the diagram blinks during mode operation to show that operation is in progress.
 2. SW output and SW output display are normally active during mode operation.
 3. SW overload can be detected and an error displayed during mode operation.
 4. For the non-display mode setting, see the initial settings mode.

■ Display range

- Use the table below to select the display range.

- Cautions:**
1. "—" line: No magnification can be selected due to the relationship between resolution and number of display digits.
 2. For the display selection setting, see the initial setting mode.

Selected No.	Pressure range
1	-100~300
2	—
3	-75~225
4	-1.00~3.00
5	-14.5~43.5
6	29.5~0.0 (Atmospheric pressure)

■ Switch output

• Use the table below to select the switch output.

- Caution:** 1. In the separate mode, Setting 1 and SW 1, and Setting 2 and SW2, operate as corresponding pairs.
 2. In the window comparator mode, SW1 and SW2 operate with a shared lower limit value (Setting 1) and upper limit value (Setting 2).
 3. For the switch output settings, see the initial settings mode.

Selected No.	Output	SW1				SW2			
	Mode	Separate		Window comparator		Separate		Window comparator	
	Operation	H	L	A	B	H	L	A	B
1		○				○			
2		○					○		
3			○					○	
4			○					○	
5				○					○
6				○					○
7					○				○
8					○				○
		Setting 1	Lower limit: Setting 1 Upper limit: Setting 2		Setting 2	Lower limit: Setting 1 Upper limit: Setting 2			

Operations consist of the four types shown in the diagram below.

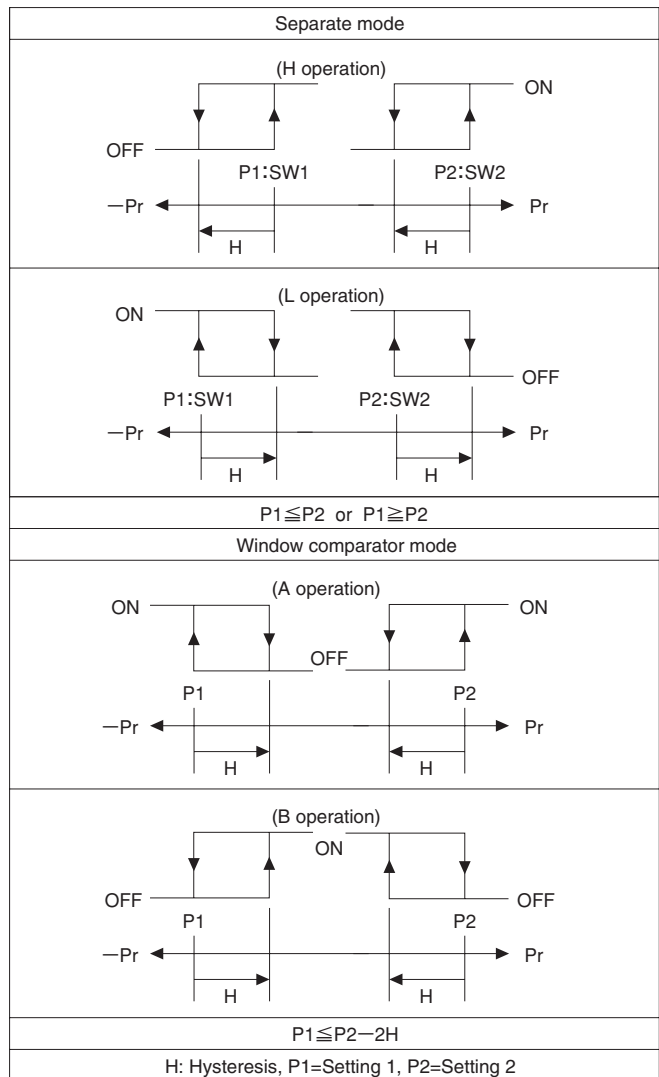

■ Digital filter

• Select from two types of digital filters (25 ms, 250 ms). Use when pressure fluctuation is severe, making the display difficult to read.

- Caution:** 1. The selected digital filter is reflected in the pressure display and switch output.
 2. For the digital filter settings, see the pressure setting mode.

(4) Operating procedure

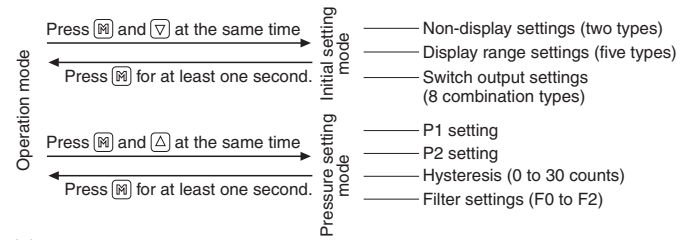

(5) Initial setting mode

• Sets the non-display mode, display range, and switch output.

■ Enter the initial setting mode



In the operation mode, press the [V] and [M] keys at the same time, for at least one second.

When initial setting mode is entered, the third digit begins blinking, to display the current setting.

Caution: The factory default setting is [2][1][1].

■ Set the initial conditions



Each single-click of the [M] key (press for less than one second) moves to the next setting digit, which begins blinking.

Operate the [V] or [A] key to select and display the setting conditions.

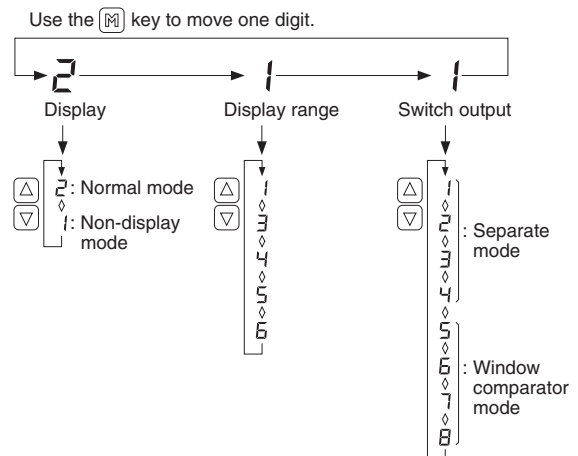

Handling Instructions and Precautions

(6) Pressure setting mode

- Sets Setting 1, Setting 2, hysteresis, and digital filter.

■ Enter the pressure setting mode



In the operation mode, press the ∇ and Δ keys at the same time, for at least one second. When initial setting mode is entered, the P1 LED starts blinking, and the current setting is displayed in the LED display. Thereafter, each click of the ∇ key (press for less than one second) moves to the next setting item. Pressing for more than one second will confirm the setting and return to the operation mode.

■ Set the pressure value



When the P1 setting is entered, the P1 LED starts blinking, and the current setting value is displayed.

- Cautions:**
1. The default setting at shipping for P1 and P2 is 0.50 .
 2. The allowable setting range is 110% or less of the rated pressure.
 3. If SW operation is in the window comparator mode, set to within the $P1 \leq P2 - 2H$ setting range.



When the P2 setting is entered, the P2 LED starts blinking, and the current setting value is displayed.

- Cautions:**
1. The allowable setting range is 110% or less of the rated pressure.
 2. If SW operation is in the window comparator mode, set to within the $P1 \leq P2 - 2H$ setting range.

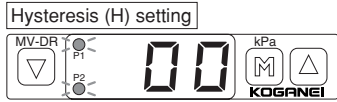

When the Hysteresis setting is entered, the P1 and P2 LEDs start blinking, and the current setting value is displayed.

- Cautions:**
1. The default setting at shipping for Hysteresis (H) is 0.0 .
 2. The allowable setting range is 30 counts or less.
 3. If SW operation is in the window comparator mode, set to within the $P1 \leq P2 - 2H$ setting range.



When the filter setting is entered, the LED does not start blinking, and the current setting value is displayed.

- Cautions:**
1. The default setting at shipping for digital filter is $F0$.
 2. Three settings are available for selection, including $F0$: no filter, $F2$: 25 ms filter, and $F3$: 250 ms filter.

(7) Zero point adjustment

■ Zero reset

When the pressure port is open, adjust the pressure display to zero. First, open the pressure port to atmosphere, and set the applied pressure to zero. In the operation mode, press the ∇ and Δ keys at the same time, and release the keys when \square starts blinking in the LED display. After about one second, the port pressure is detected, and it corrects to the zero point.



When \square stops blinking, the adjustment is complete. The adjusted value remains in effect until the next zero point adjustment.

(8) Setting protection

■ Panel lock

Lock the key operation to protect the setting value. In the operation mode, hold down the Δ key for at least three seconds, until \square starts blinking in the LED display, to enter the locked condition. Display and output operations function normally even while the lock is activated. In the operation mode, hold down the ∇ key for at least three seconds, until \square starts blinking in the LED display, to release the locked condition.



Since the panel lock condition is held in memory, it remains valid even after a restart.

Wiring instructions

■ Basic connections

●D (MV-D): Switch 2-output (fixed hysteresis)

●DR (MV-DR): Switch 2-output (variable hysteresis)

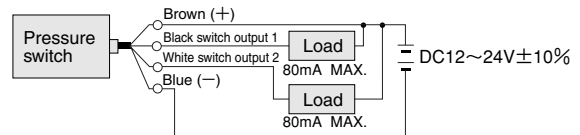

●DA (MV-DA):

Switch 1-output (variable hysteresis) + analog output

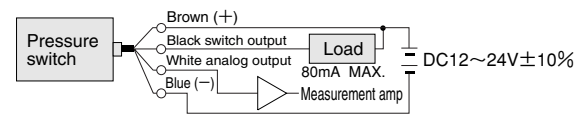

■ Connection with programmable controller

●D (MV-D): Switch 2-output (fixed hysteresis)

●DR (MV-DR): Switch 2-output (variable hysteresis)

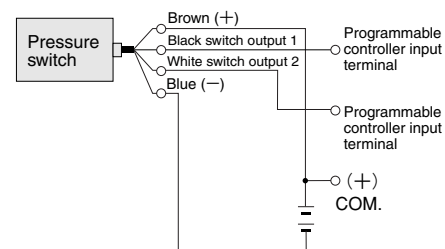

●DA (MV-DA):

Switch 1-output (variable hysteresis) + analog output

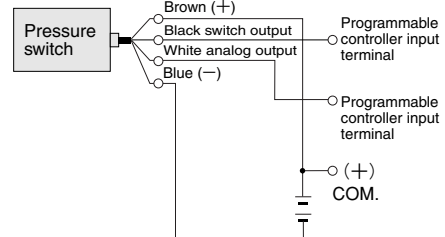

- Cautions:**
1. For the power supply, use a stable DC power source. If using a switching power source or other unit power source, ground it with an FG terminal.
 2. Pay attention to the lead wire colors when connecting the wiring. A misconnection could result in operation errors or damage.
 3. Do not connect so that the switch output terminal shorts other terminals, or connect low-resistance loads so that the current exceeds 80 mA. The internal circuits will be damaged.
 4. For solenoid relays or other inductive loads, use a surge protection diode, etc.

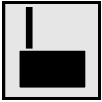

Pressure sensor

Sensor head, coupled pressure sensor head

1. Pressure sensor circuit diagram

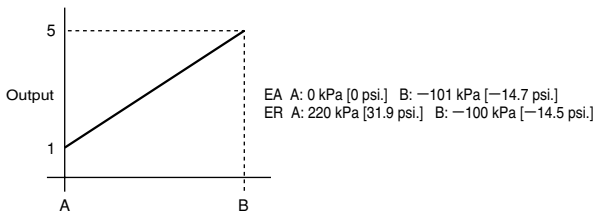
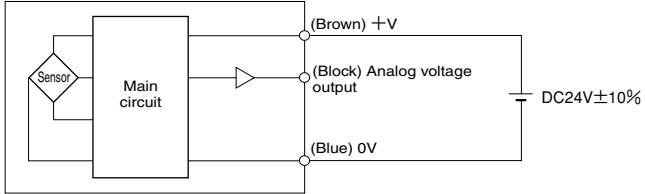

2. Use the pressure sensor on equipment with input impedance of 10 k Ω or more.
3. Do not pull on or otherwise apply excessive force to the pressure sensor cable.
4. The pressure sensor has analog output only. If switch output is required, a separate pressure sensor controller is necessary. We recommend the multi-channel pressure sensor controller (**PSU-□**). For details of the multi-channel pressure sensor controller, see p.780.

How to Choose 2-Way or 3-Way Valves

2-way valve type and 3-way valve type

The Vacuum Valve Units have two types for its vacuum supply valve, a 2-way valve and a 3-way valve.

Their characteristics include:

2-way valve type: Can maintain vacuum when a vacuum supply valve is OFF.

Can set a vacuum breaking valve to high pressure. Currently existing product.

3-way valve type: Can cause the picked items to fall under their own weight when a vacuum supply valve is OFF.

When using a vacuum breaking valve, can return to positive pressure in less time than the 2-way valve type.

This model shows the waveform for vacuum break characteristics.

Figure 1 shows the 2-way valve type.

The duration from switch off the vacuum supply valve and switch on the vacuum breaking valve to the time when inflow positive pressure exceeds the atmospheric pressure line is vacuum breaking time t_0 .

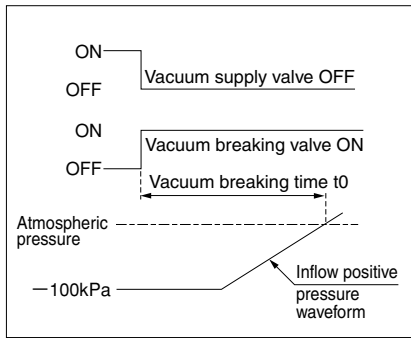

Figure 1

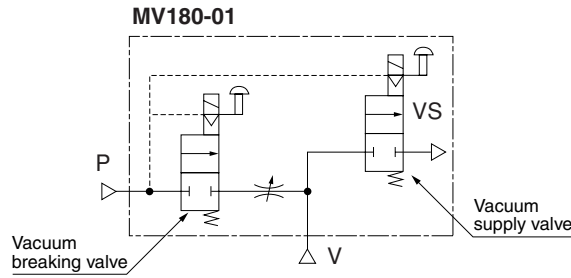

Figure 2 shows the 3-way valve type.

The duration from switch off the vacuum supply valve to the time when inflow atmospheric pressure doubles the atmospheric pressure line is vacuum breaking time t_1 .

Figure 3 shows the 3-way valve type.

The duration from switch off the vacuum supply valve and switch on the vacuum breaking valve to the time when inflow positive pressure and atmospheric pressure exceeds the atmospheric pressure line is vacuum breaking time t_2 .

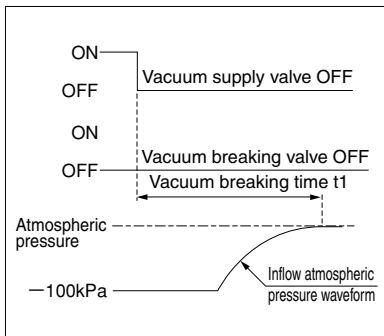

Figure 2

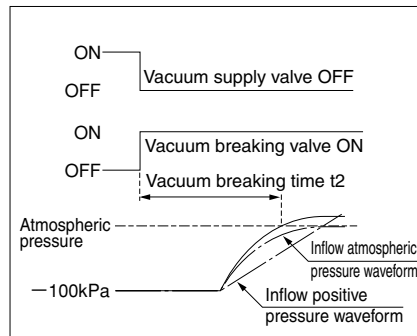
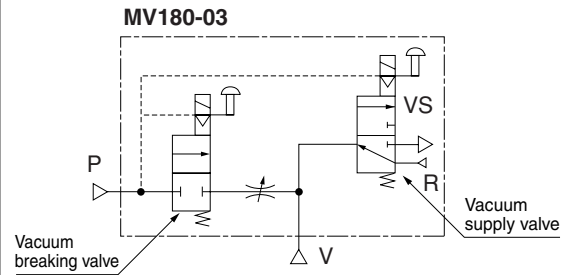

Figure 3



Because the vacuum breaking flow rate is identical, the 3-way valve type has atmosphere inflow from the R port. This results in a quick starting waveform, and $t_2 < t_0$ or $t_2 < t_1$. Another characteristic is the sluggish rise in breaking pressure due to the fact that breaking air flows to the R port after a vacuum break. For this reason, the 3-way valve type is recommended when a soft vacuum breaking during high tact time is needed, and the 2-way valve type is better when a high vacuum breaking pressure is required or when vacuum must be maintained after the vacuum supply valve is turned OFF.

Examples

MV030-01, -03 comparison

Chamber 15 cc [0.92 in.³], vacuum break flow rate 5 l/min [0.18 ft.³/min.] (ANR), supply vacuum -99 kPa [-29.2 in.Hg]

	2-way valve type (-01)	3-way valve type (-03)
ΔT	232 ms	132 ms

MV090-01, -03 comparison

Chamber 60 cc [3.66 in.³], vacuum break flow rate 5 l/min [0.18 ft.³/min.] (ANR), supply vacuum -99 kPa [-29.2 in.Hg]

	2-way valve type (-01)	3-way valve type (-03)
ΔT	732 ms	200 ms

● Measurement method

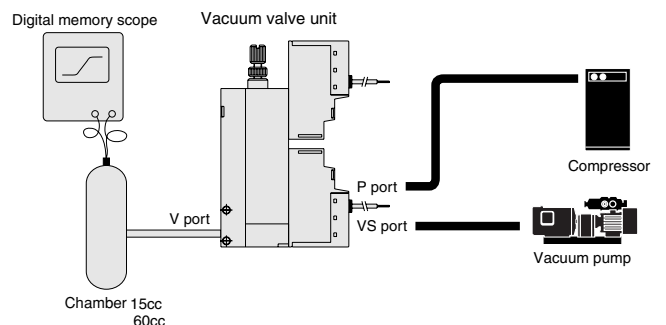

In addition to the V vacuum port, the -0※B type is also equipped with a D vacuum break port. For example, configuration of a pneumatic circuit as shown in (1) and (2) can obtain vacuum breaking air that is clean.

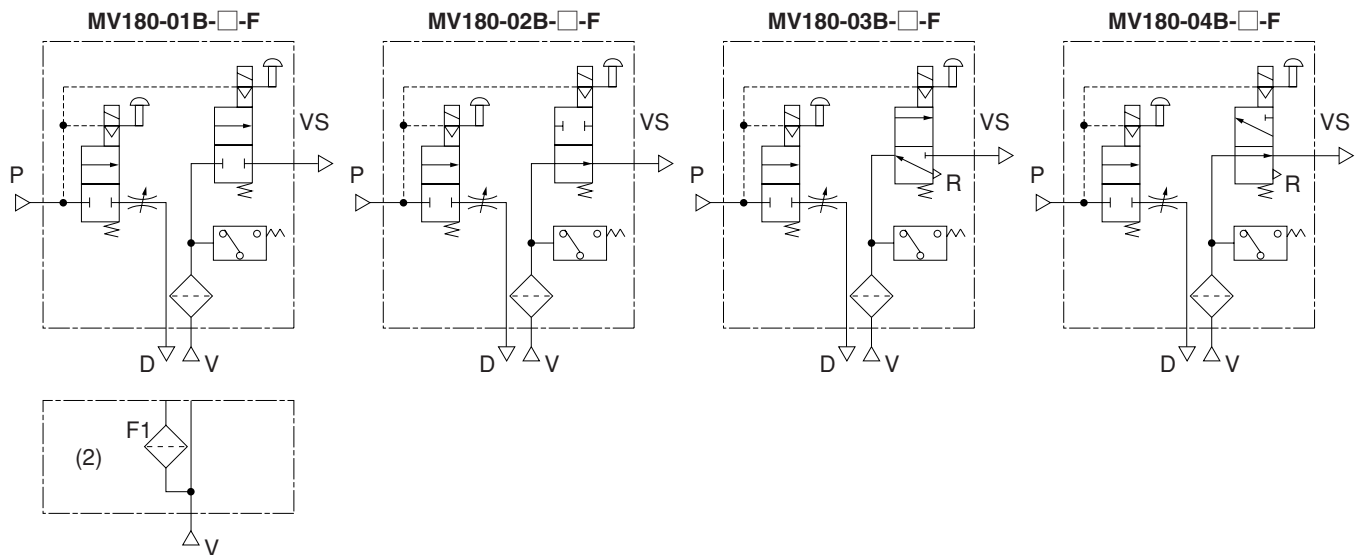
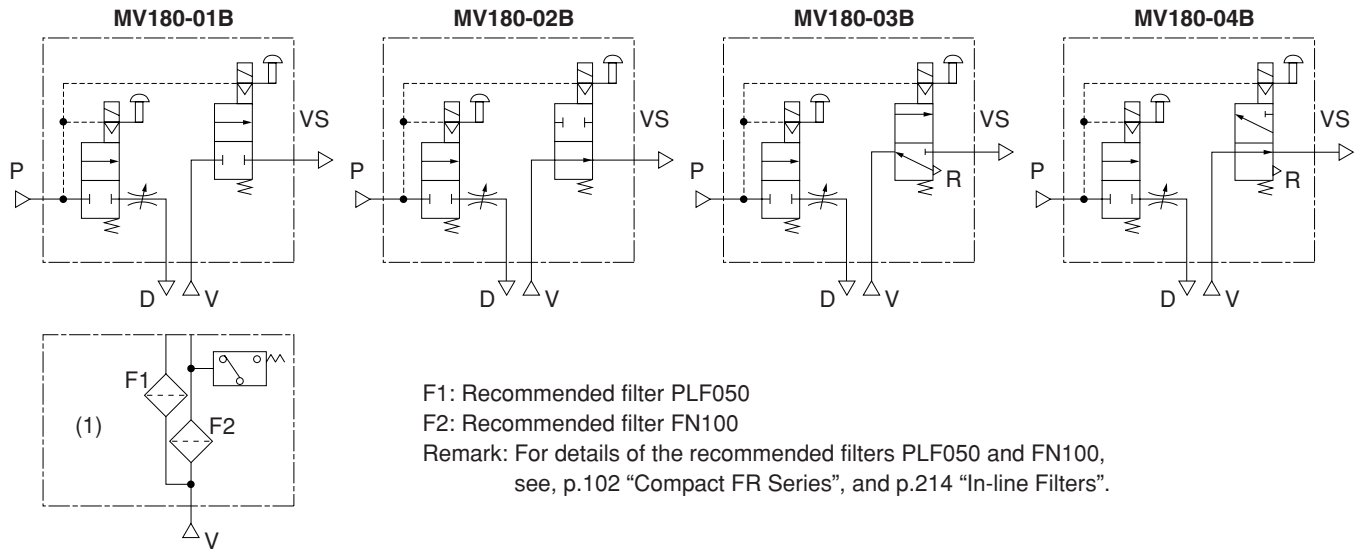

Operation Principles and Major Parts

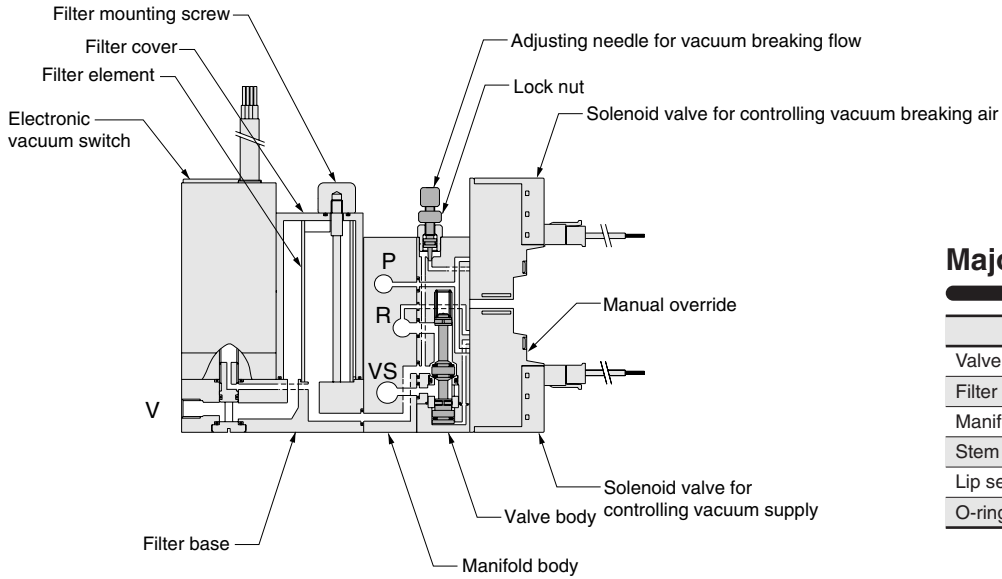

Major parts

Parts	Materials
Valve body	Plastic
Filter portion	Plastic
Manifold body	Aluminum alloy
Stem	Aluminum alloy
Lip seal	Synthetic rubber
O-ring	Synthetic rubber

●-01, -03, -05

(-05 does not have a solenoid valve for controlling vacuum breaking air)

- When energizing a solenoid valve for controlling supply air

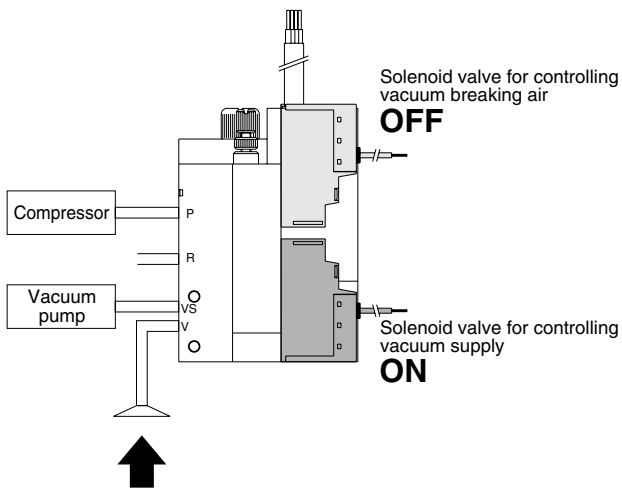

- When energizing solenoid valve for controlling vacuum breaking air

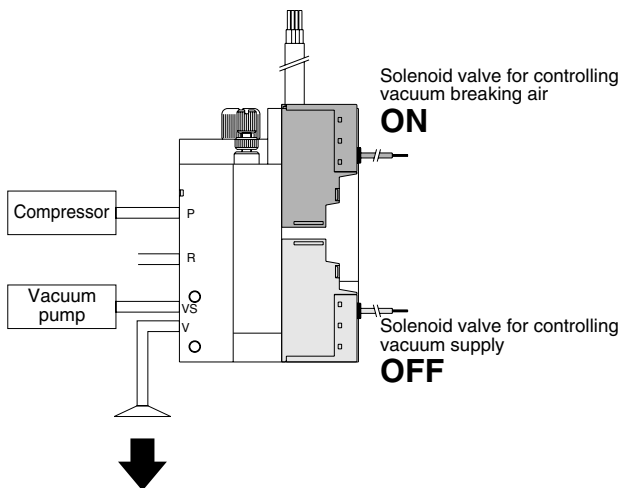

●-02, -04, -06

(-06 does not have a solenoid valve for controlling vacuum breaking air)

- When energizing solenoid valve for both controlling

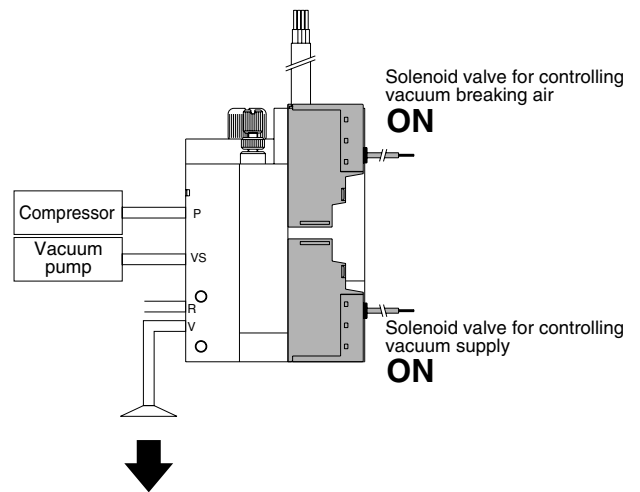

- When not energizing solenoid valve for both controlling

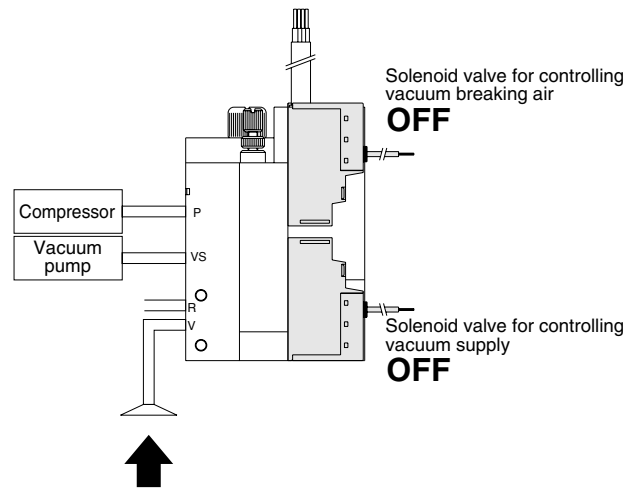

VACUUM VALVE UNITS

MV030, MV090

Specifications

Basic model		MV030	MV090
Item			
Media		Air	
Operating pressure range		-100~0 kPa [-29.54~0 in.Hg], 0~0.7 MPa [0~102 psi.]	-100~0 kPa [-29.54~0 in.Hg], 0.3~0.7 MPa [44~102 psi.]
Proof pressure	MPa [psi.]	1.05 [152]	
Operating temperature range	°C [°F]	5~50 [41~122]	
Vacuum flow rate	ℓ/min [ft. ³ /min.] (ANR)	5 [0.18]	20 [0.71]
Effective area (Positive pressure/vacuum)	mm ² [Cv]	0.2/0.55 [0.011/0.031]	0.2/2 [0.011/0.11]
Lubrication		Prohibited	
Filtration	μm	30	
Mounting direction		Any	
Main valve specifications	Operation type	Direct acting	Indirect acting
	Number of vacuum supply ports	2 or 3 ports	
	Valve function	Normally closed (NC)/Normally open (NO)	
	Shock resistance	1373 [140] (axial direction) 196 [20]	
	Mounting valve	GAV010HE1	GA010E1

Solenoid specifications

Mounting solenoid valve model		GAV010HE1		GA010E1, GAV010E1-11	
Rated voltage		DC12V	DC24V	DC12V	DC24V
Operating voltage range	V	10.8~13.2 (12±10%)	21.6~26.4 (24±10%)	10.8~13.2 (12±10%)	21.6~26.4 (24±10%)
Current (When rated voltage is applied)	Starting	mA	267	133	84
	Holding	mA	92	46	84
Power consumption	Starting	W	3.2		1.0
	Holding	W	1.1		1.0
Maximum allowable leakage current	mA	10	5	2.0	
Starting state time	ms	48	27	—	—
Insulation resistance	MΩ	100 min.			
Wiring and lead wire length		Grommet type: 300 mm [11.8 in.], plug connector type: 300, 1000, 3000 mm [11.8, 39.4, 118 in.]			
Color of lead wire		Red (+), Black (-)			
Color of LED indicator		Red			
Surge suppression (as standard)		Flywheel diode			

Mounting solenoid valve

Model	Solenoid valve for controlling vacuum supply	Solenoid valve for controlling vacuum breaking air
(A)MV030-01	GAV010HE1	GAV010E1-11
(A)MV030-02	GAV010HE1-11	GAV010E1-11
(A)MV030-03	GAV010HE1	GA010E1
(A)MV030-04	GAV010HE1-11	GA010E1
(A)MV030-05	GAV010HE1	—
(A)MV030-06	GAV010HE1-11	—

Model	Solenoid valve for controlling vacuum supply	Solenoid valve for controlling vacuum breaking air
(A)MV090-01	GA010E1	GAV010E1-11
(A)MV090-02	GA010E1	GAV010E1-11
(A)MV090-03	GA010E1	GA010E1
(A)MV090-04	GA010E1	GA010E1
(A)MV090-05	GA010E1	—
(A)MV090-06	GA010E1	—

Electronic Vacuum Switch Specifications

Item		Model	(A) MV0□0-□□-D (MV-D)	(A) MV0□0-□□-DR (MV-DR)	(A) MV0□0-□□-DA (MV-DA)	
		Type	Switch 2-output (fixed hysteresis)	Switch 2-output (variable hysteresis)	Switch 1-output (variable hysteresis+analog output)	
General	Pressure range		0~100 kPa [0~29.54 in.Hg]	300~100 kPa [43.5~14.5 psi.]	0~100 kPa [0~29.54 in.Hg]	
	Maximum pressure		200 kPa [29 psi.]	600 kPa [87 psi.]	200 kPa [29 psi.]	
	Operating temperature		-10~60°C [14~140°F]			
	Operating ambient humidity		35~85%RH			
	Applicable media		Air or non-corrosive gas			
	Insulation resistance		100 MΩ MIN. (at DC500V meggar)			
	Cable		Shielded 4-lead X 1500 mm [59 in.]			
Power supply	Voltage		DC12~24V±10%			
	Consumption current		35 mA MAX.(24V, when output is ON)			
Switch output	Number of outputs		2		1	
	Output method		NPN open collector			
	Pressure setting method		Variable, with use of a trimmer			
	Pressure setting range		0~100% of rated pressure			
	Output display		When ON, operations indicator (LED) lights up.			
	Accuracy		±3% F.S. MAX. (temperature range of 0~50°C [32~122°F], with 25°C [77°F] as a reference point)			
	Hysteresis		2% F.S. or less, fixed	0 to 30 counts variable	Approximately 0~15% F.S., variable	
	Switch capacity		DC30V, 80 mA MAX.			
Analog output	Output voltage				1~5V	
	Zero-point voltage (VZERO)				1±0.1V	
	Span voltage (VSPAN)				4±0.1V	
	Temperature characteristics	VZERO		—		±0.1% F.S./°C (temperature range of 0~50°C [32~122°F], with 25°C [77°F] as a reference point)
		VSPAN				±0.1% F.S./°C (temperature range of 0~50°C [32~122°F], with 25°C [77°F] as a reference point)
	Output current					1 mA MAX. (load resistance 5 kΩ MIN.)
Linearity/hysteresis					±0.5% F.S.MAX.	
Environmental characteristics	Vibration resistance		98.1 m/s² [10 G]			
	Shock resistance		196 m/s² [20 G]			

Pressure sensor^{Note}

● Sensor head, coupled pressure sensor head

Item		Models	(A) MV0□0-□□-EA (MV-EA)	(A) MV0□0-□□-ER (MV-ER)	
		Type			
Media			Air or non-corrosive gas		
Power supply	Voltage		DC24V±10%		
	Power consumption		6 mA or less		
Analog output	Output voltage		1~5V		
	Zero-point voltage (VZERO)		1±0.05V	3.75±0.05V	
	Span voltage (VSPAN)		4.00±0.07V (reference value)		
	Temperature characteristics	VZERO		±30 mV or less (at 0~50°C [32~122°F])	
		VSPAN		±2%FS or less (at 0~50°C [32~122°F])	
Output current		1 mA MAX (load resistance 5 kΩ or more)			
General	Operating pressure range		0~101.3 kPa [0~29.92 in.Hg]	-100~220 kPa [-14.5~31.9 psi.]	
	Proof pressure		+900 kPa [130.5 psi.]		
	Operating temperature range		0~50°C [32~122°F] Storage -20~80°C [-4~176°F] (storage: humidity 65%RH or less, atmospheric pressure)		
	Operating humidity range		35~85%RH		
	Insulation resistance		100 MΩ MIN (at DC500V meggar)		
	Dielectric strength		AC500V, 1 minute		
	Cable		Oil-resistant, bend-resistant PCCV 0.15SQX3 leads 3000 mm [118 in.]		

Note: The pressure sensor has analog output only. If switch output is required, a separate pressure sensor controller is necessary.

We recommend the multi-channel pressure sensor controller (PSU-□). For details of the multi-channel pressure sensor controller, see p.780.

Mass

● Single unit

g [oz.]

Basic model	Body mass		Additional mass		
	-01, -02, -03, -04	-05, -06	Filter	Vacuum switch	Sensor head
			-F	-D, -DR, -DA	-EA, -ER
MV030	42 [1.48]	31 [1.09]	28 [0.99]	50 [1.76]	34 [1.20]
MV090	58 [2.05]	47 [1.66]	28 [0.99]	50 [1.76]	34 [1.20]

Calculation sample For **MV090-03-F-D**

$$= 58 + 28 + 50$$

$$= 136 \text{ g [4.80 oz.]}$$

● Manifold

g [oz.]

Basic model	Valve body mass		Additional mass		
	-01, -02, -03, -04	-05, -06	Filter	Vacuum switch	Sensor head
			-F	-D, -DR, -DA	-EA, -ER
AMV030	26 [0.92]	15 [0.53]	22 [0.78]	50 [1.76]	34 [1.20]
AMV090	36 [1.27]	25 [0.88]	22 [0.78]	50 [1.76]	34 [1.20]

● Manifold base

g [oz.]

Number of units	2 units	3 units	4 units	5 units	6 units	7 units	8 units
MV030M□□, MV090M□□	60 [2.12]	77 [2.72]	95 [3.35]	115 [4.06]	130 [4.59]	148 [5.22]	165 [5.82]

Calculation sample For **MV090M8AS**, str. 1~8 **AMV090-02-F-D**

$$= 165 + (36 + 22 + 50) \times 8$$

$$= 1029 \text{ g [36.30 oz.]}$$

Symbols

MV030-01 (AMV030-01)

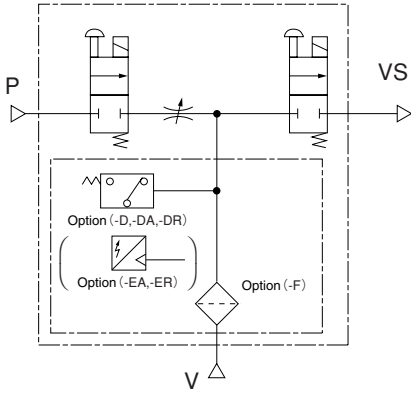

MV030-02 (AMV030-02)

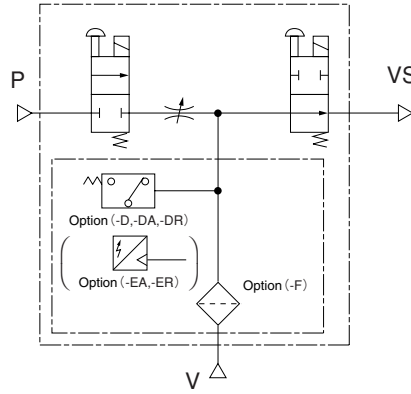

MV030-03 (AMV030-03)

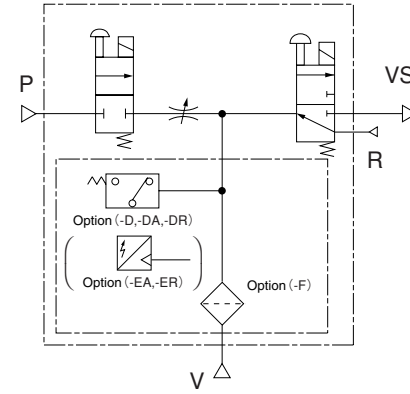

MV030-04 (AMV030-04)

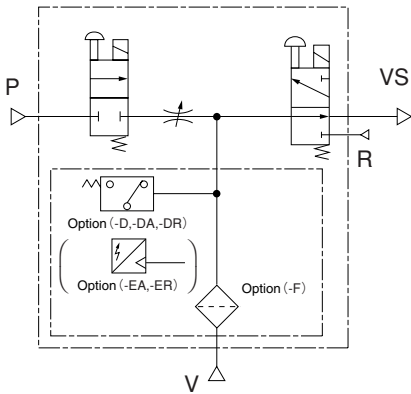

MV030-05 (AMV030-05)

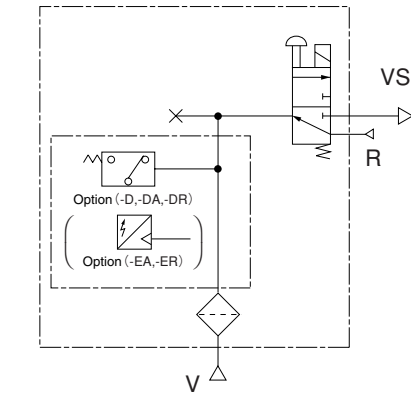

MV030-06 (AMV030-06)

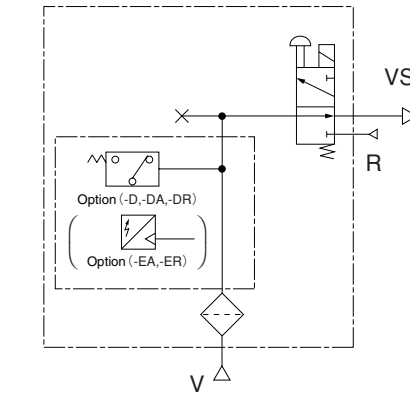

Note: In the manifold type, the P port, VS port, and R port are equipped to the manifold sharing each station.

MV090-01 (AMV090-01)

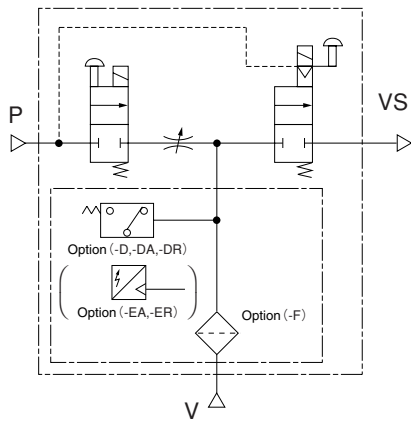

MV090-02 (AMV090-02)

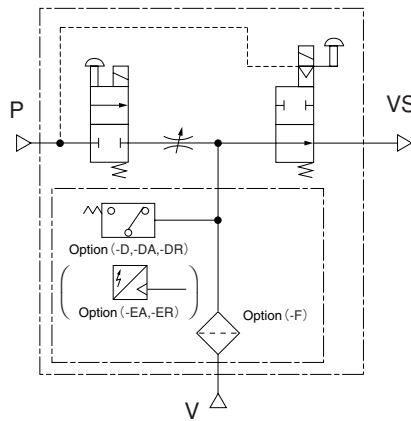

MV090-03 (AMV090-03)

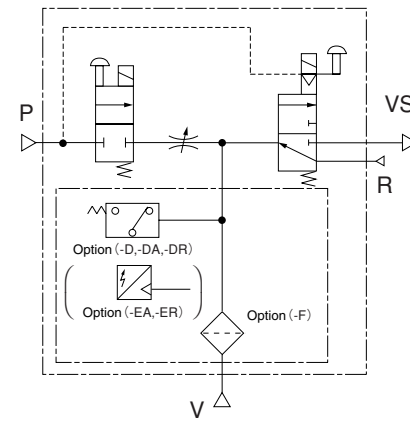

MV090-04 (AMV090-04)

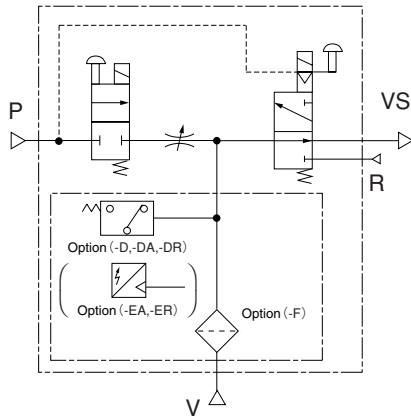

MV090-05 (AMV090-05)

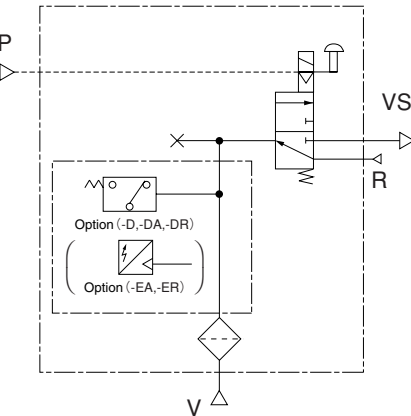

MV090-06 (AMV090-06)

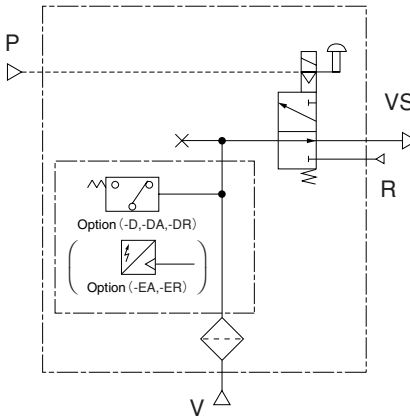

Note: In the manifold type, the P port, VS port, and R port are equipped to the manifold sharing each station.

Single Unit Order Codes

Model

MV030

Effective area for vacuum supply 0.55 mm² [Cv=0.0306] (V→VS)

MV090

Effective area for vacuum supply 2.0 mm² [Cv=0.111] (V→VS)

Valve unit configuration

-01

Vacuum supply control 2-way valve normally closed (NC)
Vacuum breaking air control 2-way valve normally closed (NC)

-02

Vacuum supply control 2-way valve normally open (NO)
Vacuum breaking air control 2-way valve normally closed (NC)

-03

Vacuum supply control 3-way valve normally closed (NC)
Vacuum breaking air control 2-way valve normally closed (NC)

-04

Vacuum supply control 3-way valve normally open (NO)
Vacuum breaking air control 2-way valve normally closed (NC)

-05

Vacuum supply control 3-way valve normally closed (NC)
No vacuum breaking air control valve

-06

Vacuum supply control 3-way valve normally open (NO)
No vacuum breaking air control valve

Electronic vacuum switch

Blank

No vacuum switch

-D

With vacuum switch 2-output fixed hysteresis type

-DR

With vacuum switch 2-output variable hysteresis type

-DA

With vacuum switch 1-output variable hysteresis type (with analog output)

(Pressure sensor ^{Note})

-EA

For negative pressure

(Pressure sensor ^{Note})

-ER

For coupled pressure

Lead wire length

Blank

300 mm [11.8 in.]

-1L

1000 mm [39.4 in.]

-3L

3000 mm [118 in.]

Filter

Blank

No filter

-F

With filter

Wiring specification

Blank

Grommet (with LED indicator)

-PL

L connector, positive common (with LED indicator)

-ML

L connector, negative common (with LED indicator)

Model	Valve unit configuration	Electronic Vacuum Switch (Pressure sensor) ^{Note}	Filter	Wiring specification	Lead wire length	Voltage
MV030 MV090	-01 -02 -03 -04	Blank	Blank -F	Blank	Blank	DC12V DC24V
				-PL -ML	Blank -1L -3L	
		-D -DR -DA -EA ^{Note} -ER ^{Note}	-F	Blank	Blank	
				-PL -ML	Blank -1L -3L	
	-05 -06	Blank -D -DR -DA -EA ^{Note} -ER ^{Note}	-F	Blank	Blank	
				-PL -ML	Blank -1L -3L	

Note: The pressure sensor has analog output only. If switch output is required, a separate pressure sensor controller is necessary. We recommend the multi-channel pressure sensor controller (PSU-□). For details of the multi-channel pressure sensor controller, see p.780.

MV030 Series Manifold Order Codes

Manifold basic model

MV030M

For mounting AMV030

Manifold model

A

A type manifold
(Without filter and vacuum switch)

AS

AS type manifold
(For mounting filter and vacuum switch)

Solenoid valve type for controlling vacuum supply

Blank

For mounting normally closed (NC) type

-11

For mounting normally open (NO) type

Model

AMV030

Effective area for vacuum supply side 0.55 mm²
[Cv: 0.0306] (V→VS)

Electronic vacuum switch

Blank

No vacuum switch

-D

With vacuum switch 2-output fixed hysteresis type

-DR

With vacuum switch 2-output variable hysteresis type

-DA

With vacuum switch 1-output variable hysteresis type (with analog output)

(Pressure sensor^{Note 2})

-EA

For negative pressure

(Pressure sensor^{Note 2})

-ER

For coupled pressure

Valve unit configuration

-01

Vacuum supply control 2-way valve normally closed (NC)

Vacuum breaking air control 2-way valve normally closed (NC)

-02

Vacuum supply control 2-way valve normally open (NO)

Vacuum breaking air control 2-way valve normally closed (NC)

-03

Vacuum supply control 3-way valve normally closed (NC)

Vacuum breaking air control 2-way valve normally closed (NC)

-04

Vacuum supply control 3-way valve normally open (NO)

Vacuum breaking air control 2-way valve normally closed (NC)

-05

Vacuum supply control 3-way valve normally closed (NC)

Without vacuum breaking air control valve

-06

Vacuum supply control 3-way valve normally open (NO)

Without vacuum breaking air control valve

Filter

Blank

No filter

-F

With filter

Wiring specification

Blank

Grommet
(With LED indicator)

-PL

L connector, positive common
(With LED indicator)

-ML

L connector, negative common
(With LED indicator)

Lead wire length

Blank

300 mm [11.8 in.]

-1L

1000 mm [39.4 in.]

-3L

3000 mm [118 in.]

Manifold basic model	Number of units	Manifold model	Solenoid valve type	Station	Model	Valve unit configuration	Vacuum switch (Pressure sensor)	Filter	Wiring specification	Lead wire length	Voltage
----------------------	-----------------	----------------	---------------------	---------	-------	--------------------------	---------------------------------	--------	----------------------	------------------	---------

	Manifold model			Mounting valve model								
A type manifold	Solenoid valve for controlling vacuum supply, normally closed type	MV030M	A	Blank	stn. □ ⋮ stn. □ Note1	AMV030	-01	Blank	Blank	Blank	Blank	DC12V DC24V
				-11			-02			-PL	Blank	
AS type manifold	Solenoid valve for controlling vacuum supply, normally open type	MV030M	AS	Blank	stn. □ ⋮ stn. □ Note1	AMV030	-03	Blank	-F	-PL	Blank	DC12V DC24V
				-11			-04			-ML	Blank	
AS type manifold	Solenoid valve for controlling vacuum supply, normally open type	MV030M	AS	Blank	stn. □ ⋮ stn. □ Note1	AMV030	-05	Blank	-F	Blank	Blank	DC12V DC24V
				-11			-06			-PL	Blank	
AS type manifold	Solenoid valve for controlling vacuum supply, normally open type	MV030M	AS	Blank	stn. □ ⋮ stn. □ Note1	AMV030	-01	Blank	-F	-PL	Blank	DC12V DC24V
				-11			-03			-ML	Blank	
AS type manifold	Solenoid valve for controlling vacuum supply, normally open type	MV030M	AS	Blank	stn. □ ⋮ stn. □ Note1	AMV030	-05	Blank	-F	Blank	Blank	DC12V DC24V
				-11			-06			-PL	Blank	

Notes: 1. Mounting location from the left so that places the vacuum breaking flow adjustment needle on top, and the vacuum port (V) side in front.
2. The pressure sensor has analog output only. If switch output is required, a separate pressure sensor controller is necessary. We recommend the multi-channel pressure sensor controller (PSU-□). For details of the multi-channel pressure sensor controller, see p.780.

Additional parts (to be ordered separately)

●Electronic vacuum switch (with digital display)

MV —

Switch specification

- D : Switch 2-output fixed hysteresis type
- DR : Switch 2-output variable hysteresis type
- DA : Switch 1-output variable hysteresis type with analog output

●Pressure sensor

MV —

Pressure specification

- EA : Negative pressure
- ER : Coupled pressure

●Mounting base

MV — 21



●Filter for replacement

MV — F

(element only, 5 pcs.)

●MV030-01

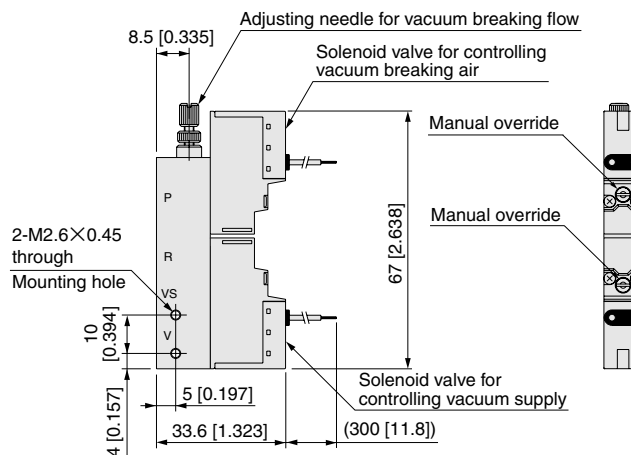
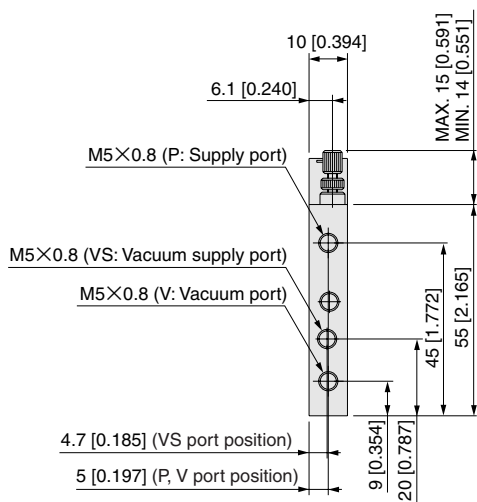

●MV030-02

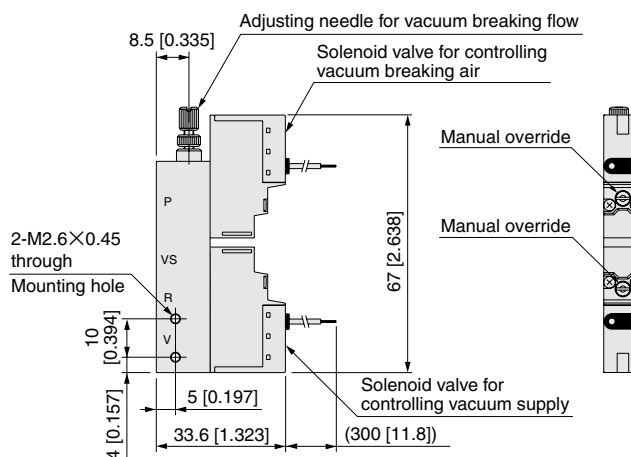
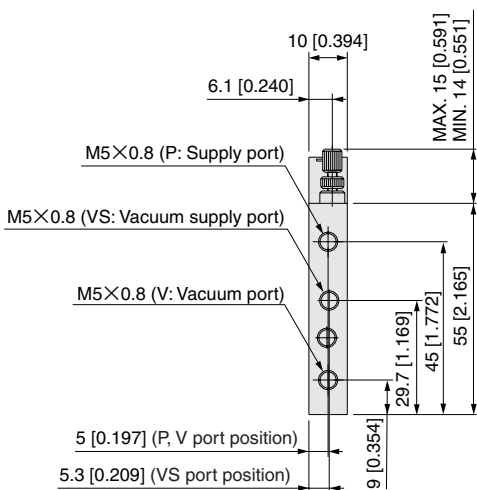

Option

●With wiring specification L connector (-PL, -ML)

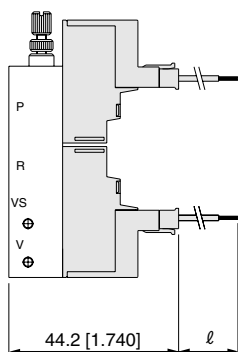

Model	Code	l
Blank		300 [11.8]
-1L		1000 [39.4]
-3L		3000 [118]

●MV030-03

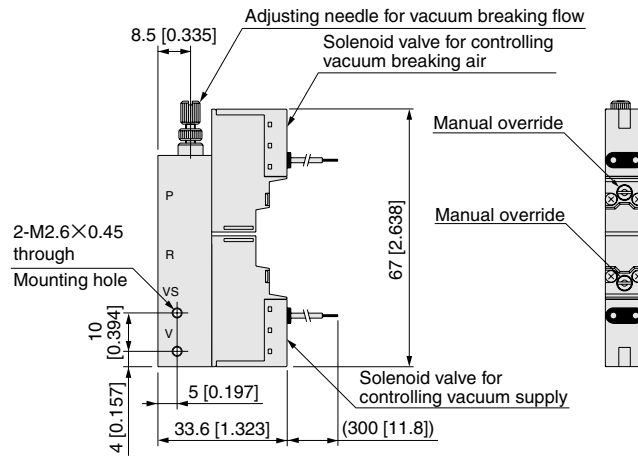
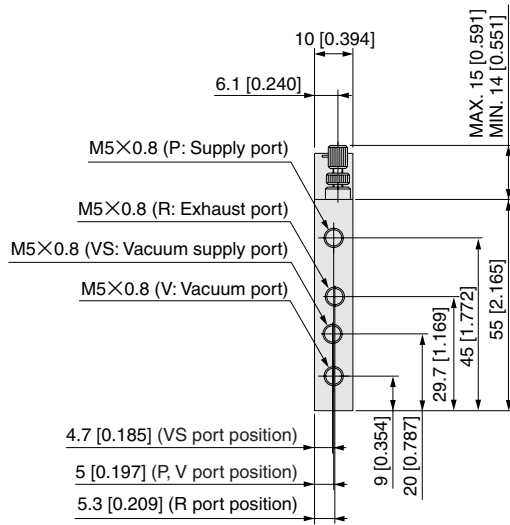

●MV030-04

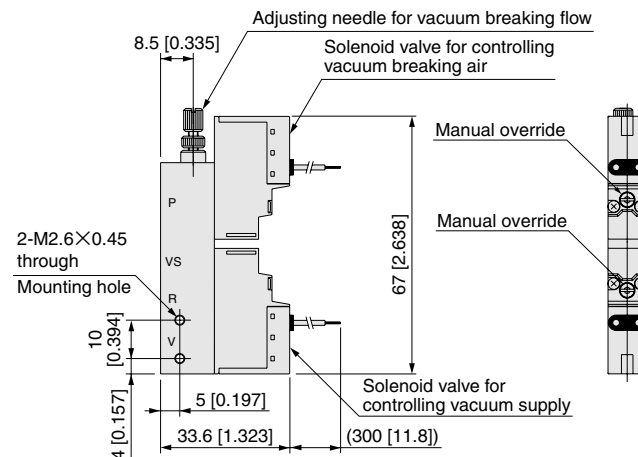
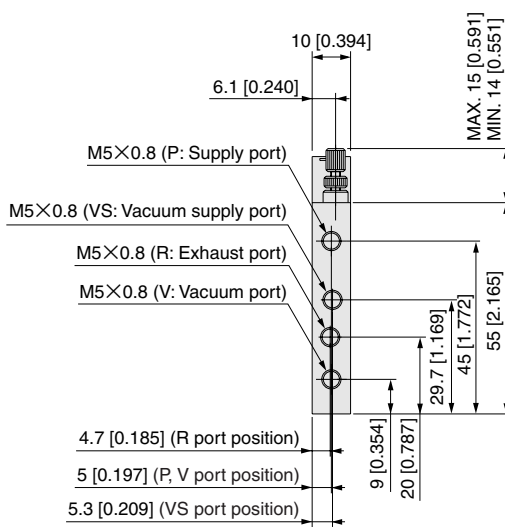

● MV030-01-□-F

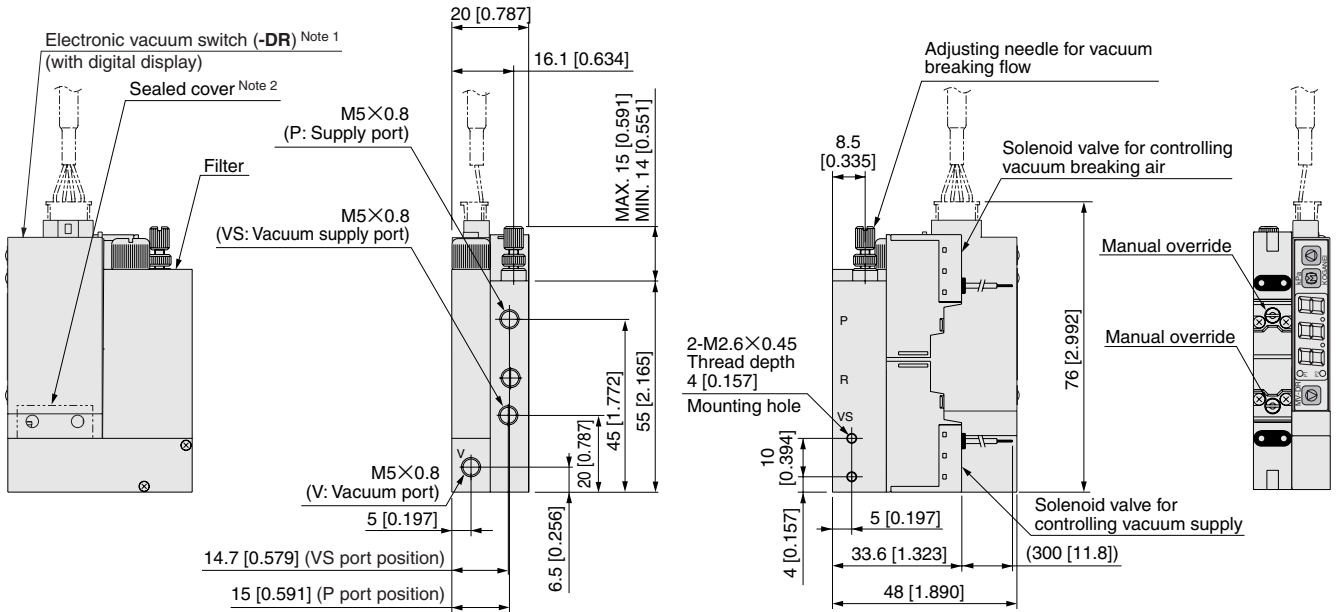

Notes: 1. The electronic vacuum switch (-DR) comes with a cable with connector.
2. For cases without electronic vacuum switch

● MV030-02-□-F

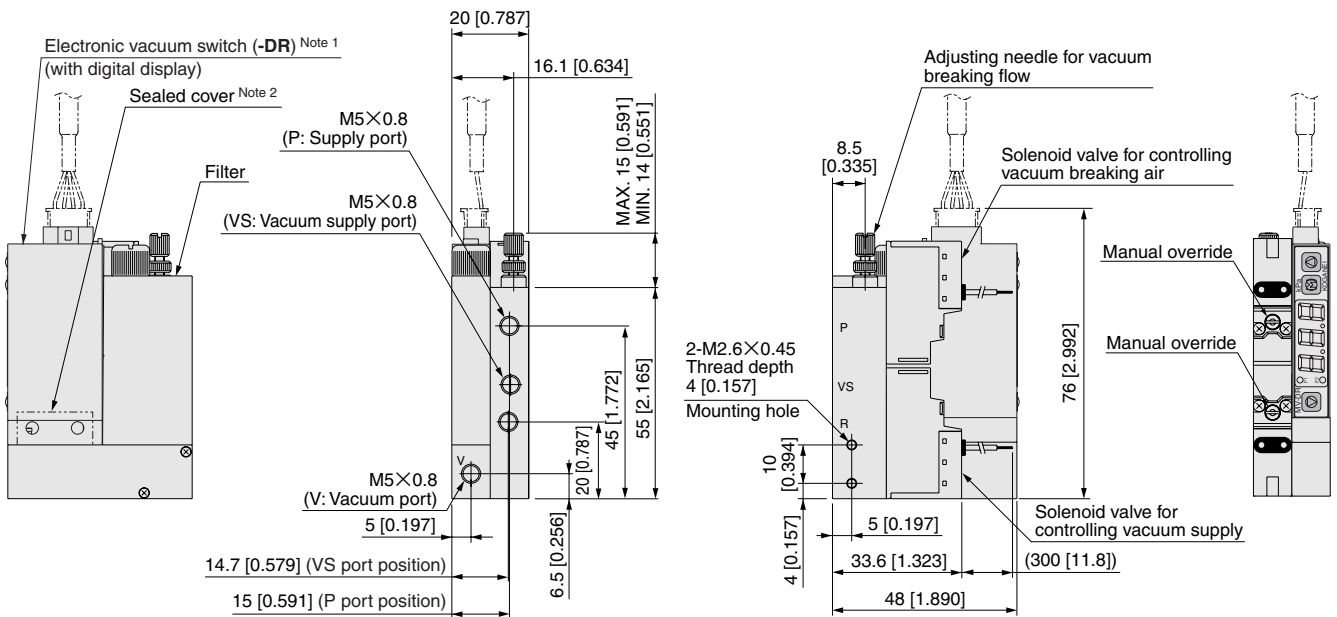

Notes: 1. The electronic vacuum switch (-DR) comes with a cable with connector.
2. For cases without electronic vacuum switch

Option

● With L connector wiring specification (-PL, -ML)

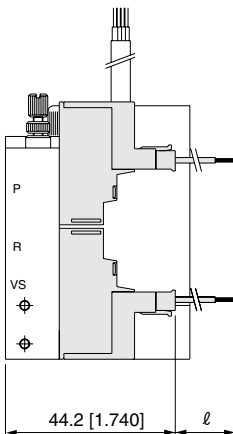

Model	Code	l
Blank		300 [11.8]
-1L		1000 [39.4]
-3L		3000 [118]

● Cable length of electronic vacuum switch (-DR)

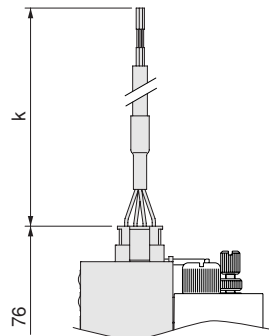

Model (wiring specifications and lead wire length)	Code	k
-PL-Blank, -PL-1L		1500 [59]
-ML-Blank, -ML-1L		1500 [59]
-PL-3L, -ML-3L		3000 [118]

Dimensions mm [in.]

● MV030-03-□-F

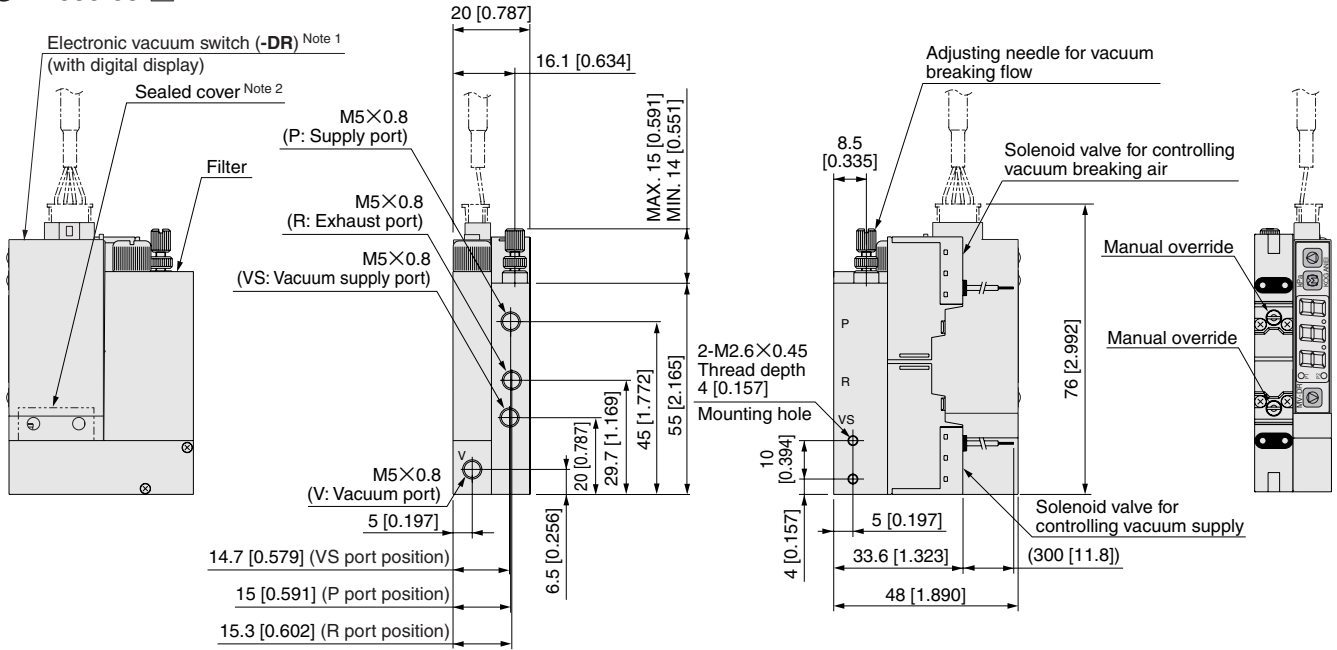

Notes: 1. The electronic vacuum switch (-DR) comes with a cable with connector.
2. For cases without electronic vacuum switch

● MV030-04-□-F

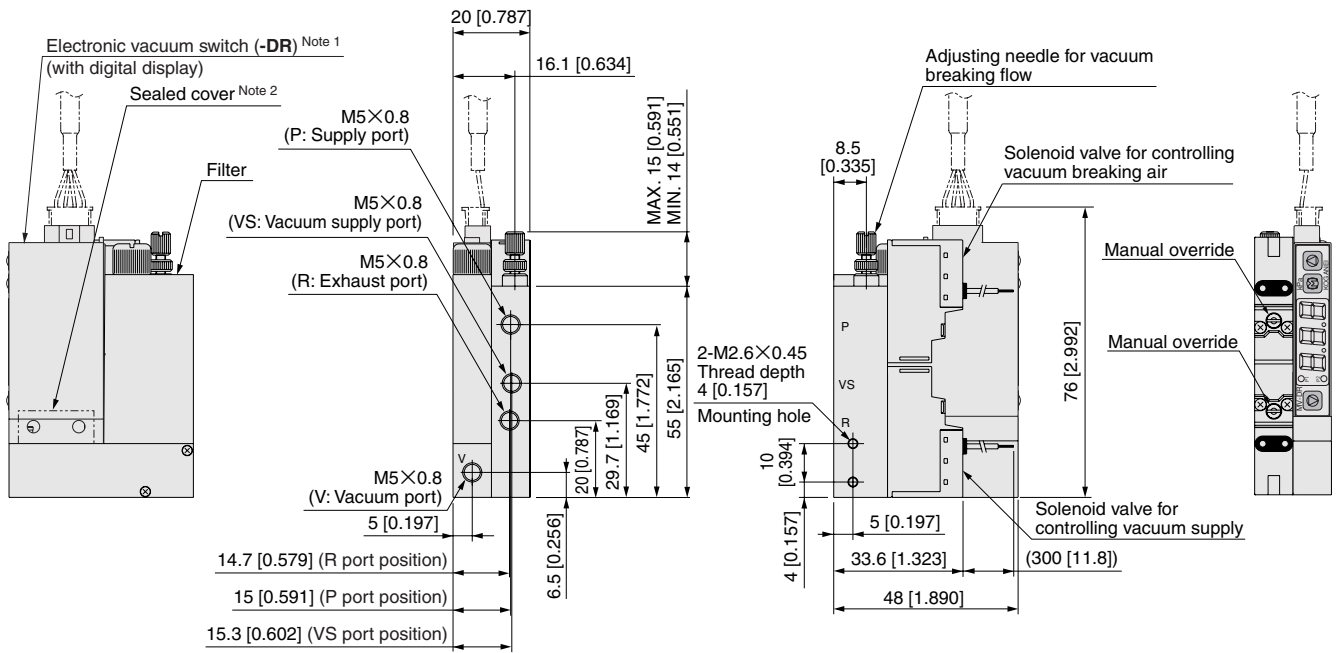

Notes: 1. The electronic vacuum switch (-DR) comes with a cable with connector.
2. For cases without electronic vacuum switch

Option

● With electronic vacuum switch (-D, -DA)

Remark: Cable length available at 1500 mm [59 in.] only.

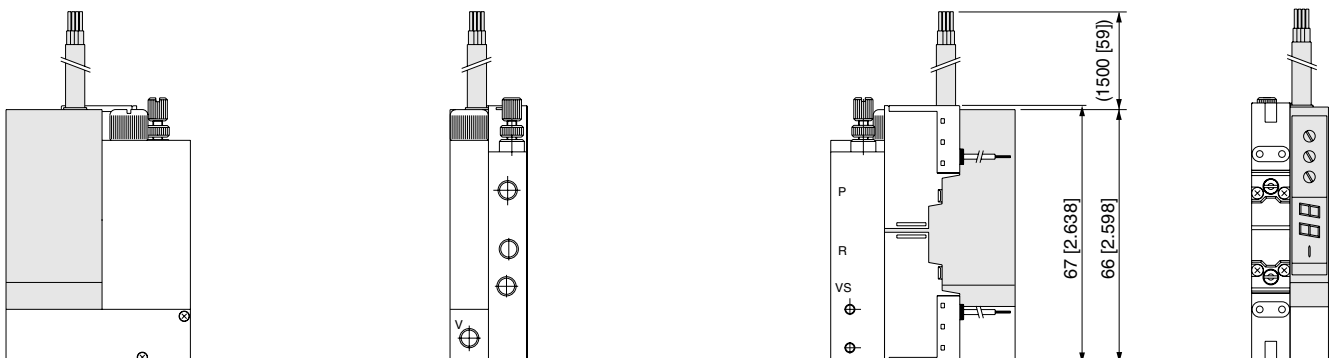

Dimensions mm [in.]

●MV030-05-□-F

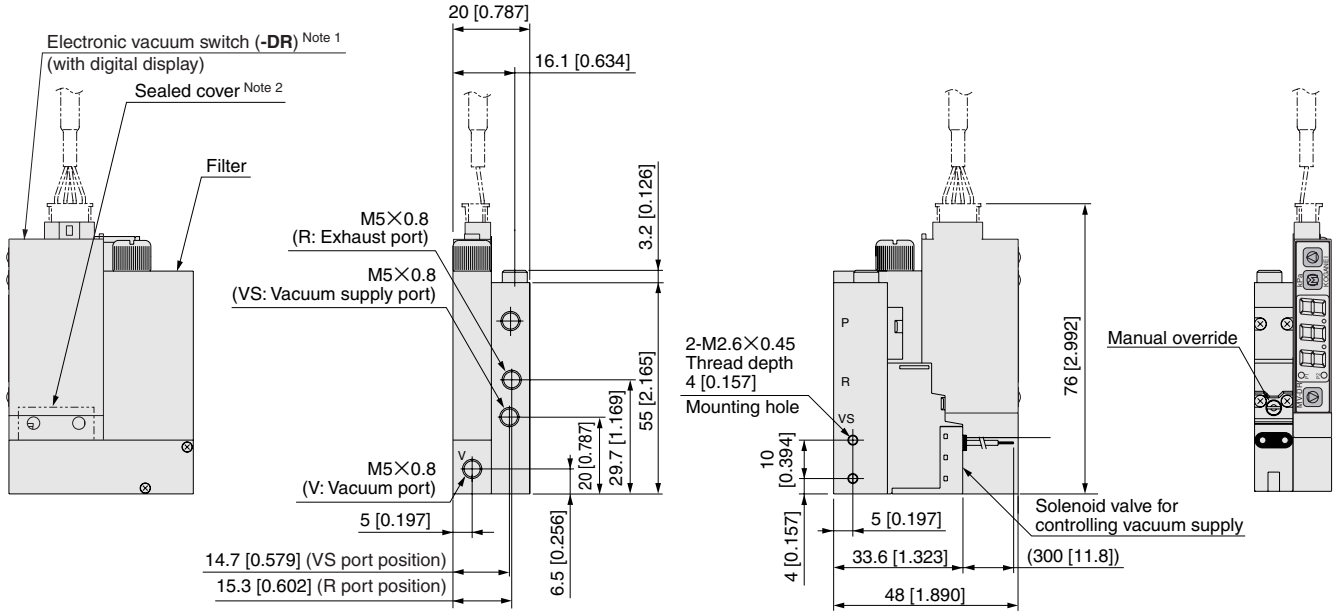

Notes: 1. The electronic vacuum switch (-DR) comes with a cable with connector.
2. For cases without electronic vacuum switch

●MV030-06-□-F

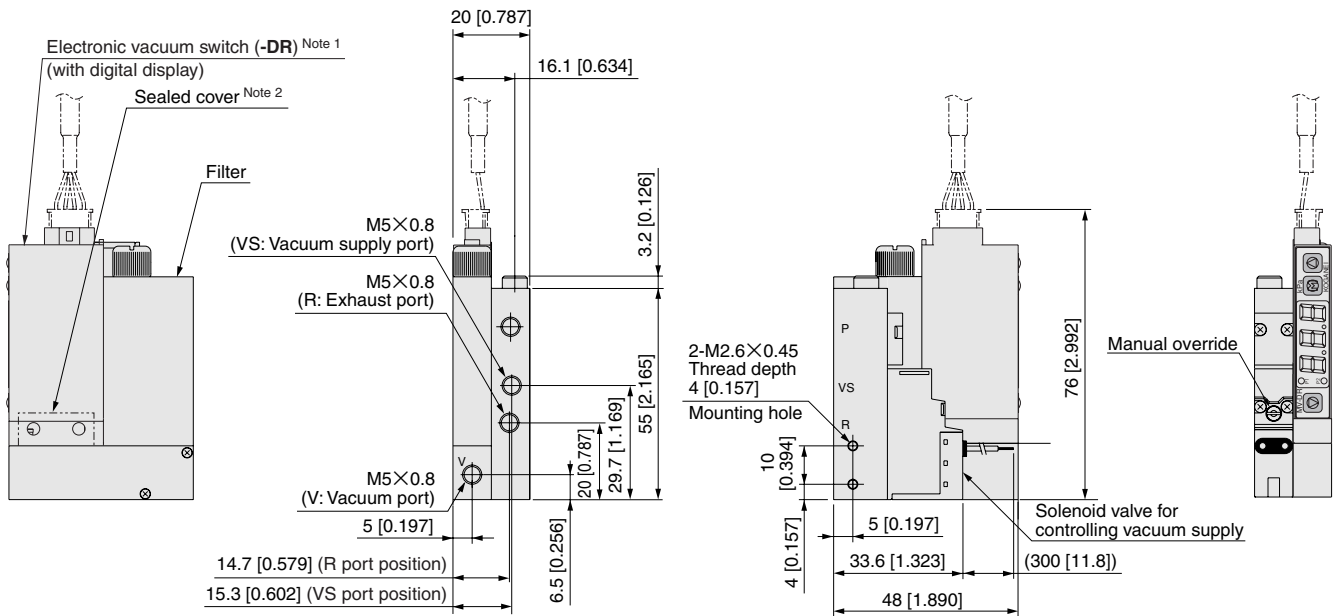

Notes: 1. The electronic vacuum switch (-DR) comes with a cable with connector.
2. For cases without electronic vacuum switch

Option

●Pressure sensor (-EA, -ER)

Remark: Cable length available at 3000 mm [118 in.] only.

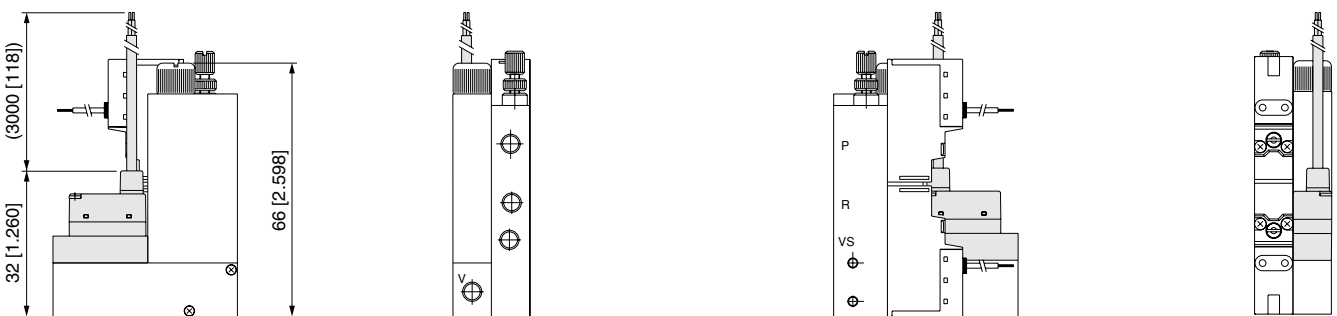

A type manifold

● MV030M8A

- stn.1,2 AMV030-01
- stn.3,4 AMV030-03
- stn.5,6 AMV030-01-PL
- stn.7,8 AMV030-03-PL

No. of units	L	P
2	28.2 [1.110]	34.2 [1.346]
3	38.4 [1.512]	44.4 [1.748]
4	48.6 [1.913]	54.6 [2.150]
5	58.8 [2.315]	64.8 [2.551]
6	69.0 [2.717]	75.0 [2.953]
7	79.2 [3.118]	85.2 [3.354]
8	89.4 [3.520]	95.4 [3.756]

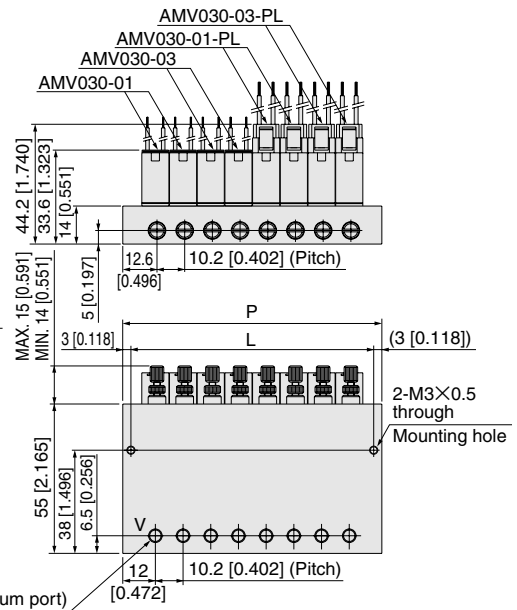
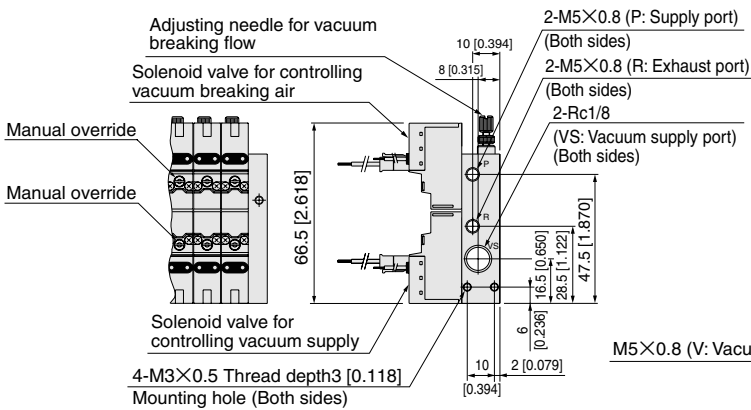

A type manifold

● MV030M8A-11

- stn.1,2 AMV030-02
- stn.3,4 AMV030-04
- stn.5,6 AMV030-02-PL
- stn.7,8 AMV030-04-PL

No. of units	L	P
2	28.2 [1.110]	34.2 [1.346]
3	38.4 [1.512]	44.4 [1.748]
4	48.6 [1.913]	54.6 [2.150]
5	58.8 [2.315]	64.8 [2.551]
6	69.0 [2.717]	75.0 [2.953]
7	79.2 [3.118]	85.2 [3.354]
8	89.4 [3.520]	95.4 [3.756]

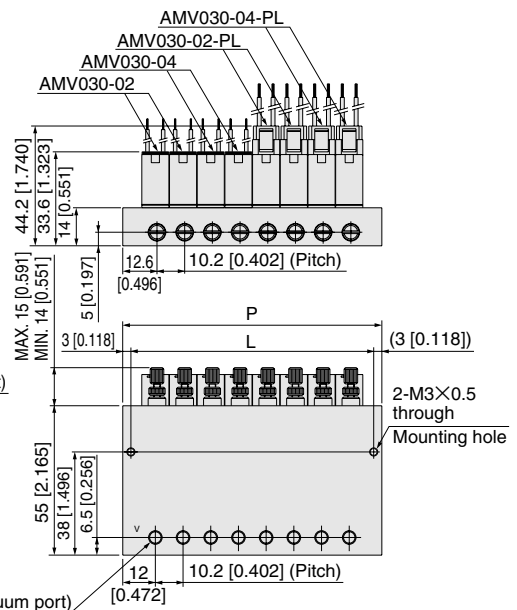
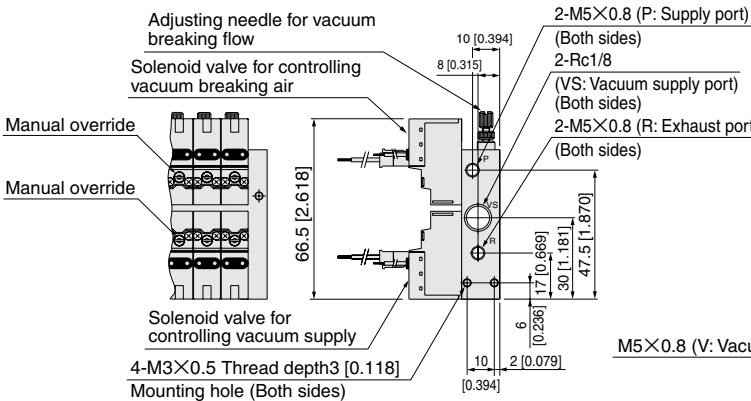

Remark: For the solenoid valve lead wire length, see the single unit dimensions on p.638.

AS type manifold (mounting for filter and vacuum switch)

●MV030M8AS

- stn.1 AMV030-05-F
- stn.2 AMV030-01-EA-F
- stn.3 AMV030-03-ER-F
- stn.4 AMV030-03-D-F
- stn.5,6 AMV030-01-DA-F-PL
- stn.7,8 AMV030-03-DR-F-PL

No. of units	L	P
2	20.2 [0.795]	31.2 [1.228]
3	30.4 [1.197]	41.4 [1.630]
4	40.6 [1.598]	51.6 [2.031]
5	50.8 [2.000]	61.8 [2.433]
6	61.0 [2.402]	72.0 [2.835]
7	71.2 [2.803]	82.2 [3.236]
8	81.4 [3.205]	92.4 [3.638]

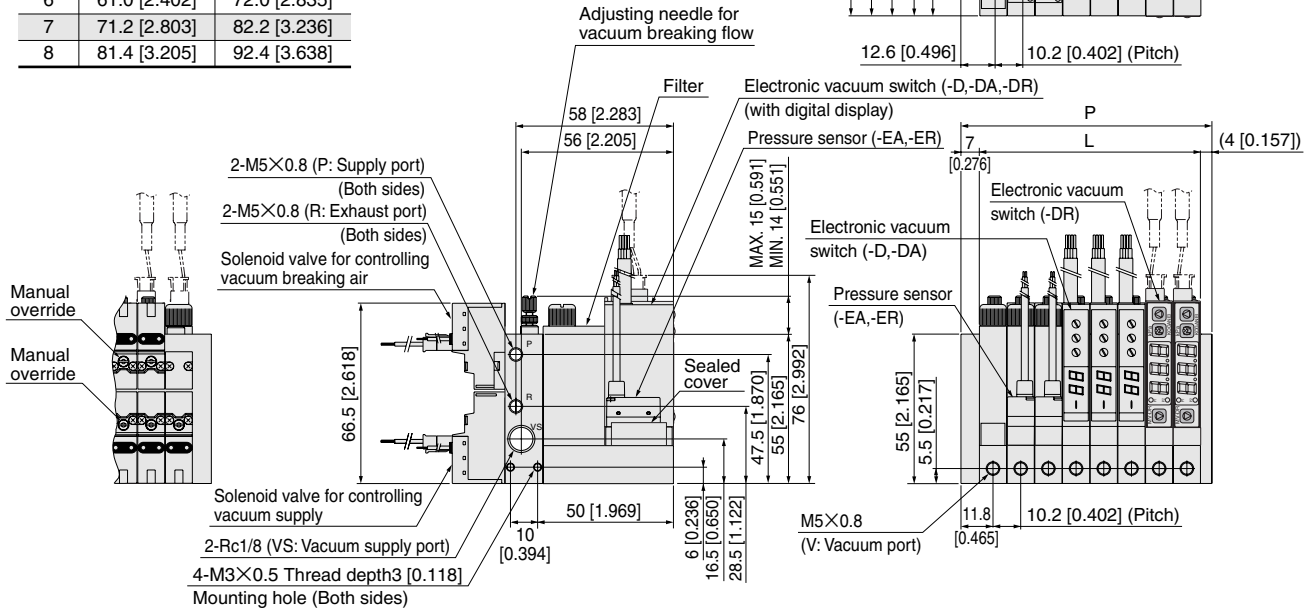
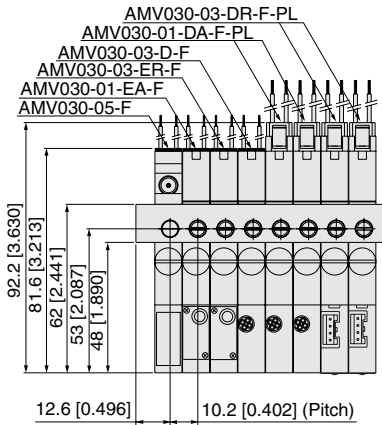

AS type manifold (mounting for filter and vacuum switch)

●MV030M8AS-11

- stn.1 AMV030-06-F
- stn.2 AMV030-02-EA-F
- stn.3 AMV030-04-ER-F
- stn.4 AMV030-04-D-F
- stn.5,6 AMV030-02-DA-F-PL
- stn.7,8 AMV030-04-DR-F-PL

No. of units	L	P
2	20.2 [0.795]	31.2 [1.228]
3	30.4 [1.197]	41.4 [1.630]
4	40.6 [1.598]	51.6 [2.031]
5	50.8 [2.000]	61.8 [2.433]
6	61.0 [2.402]	72.0 [2.835]
7	71.2 [2.803]	82.2 [3.236]
8	81.4 [3.205]	92.4 [3.638]

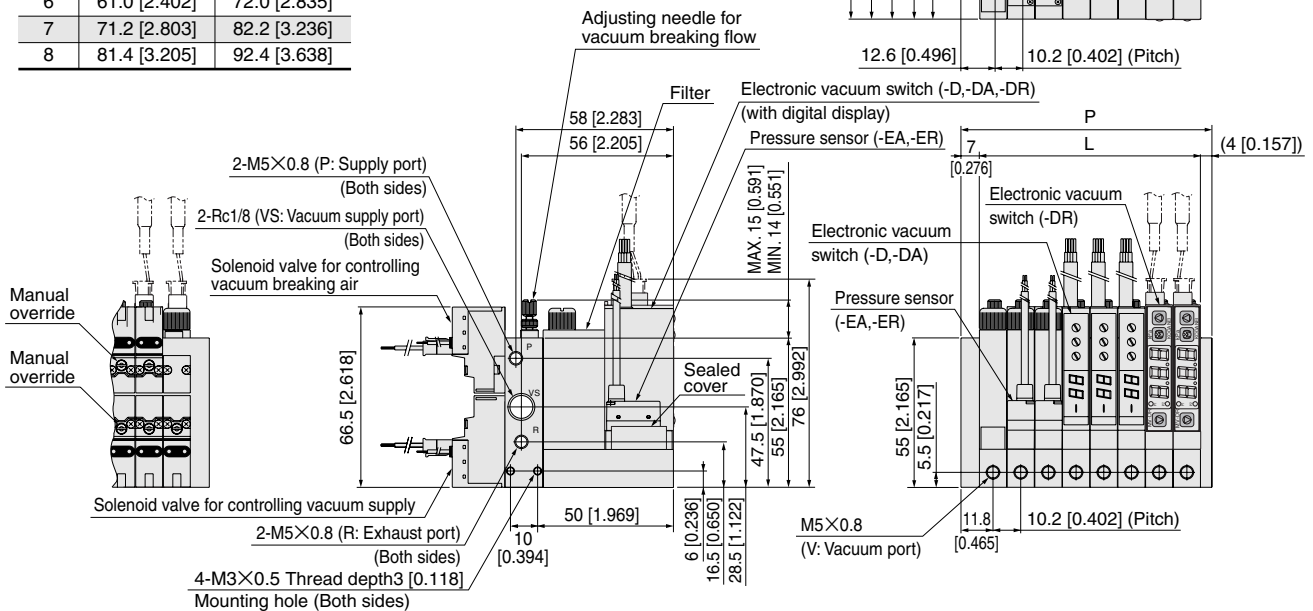
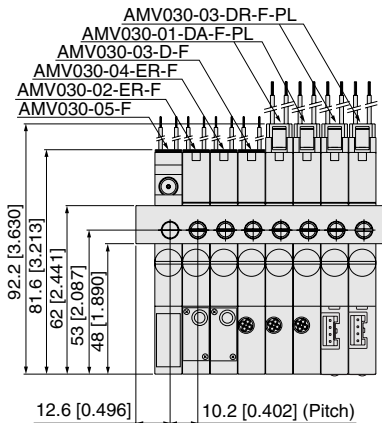

Remark: For the solenoid valve lead wire length, electronic vacuum switch, and pressure sensor cable length, see the single unit dimensions on p.640~642.

Dimensions mm [in.]

● **Mounting base MV-21**

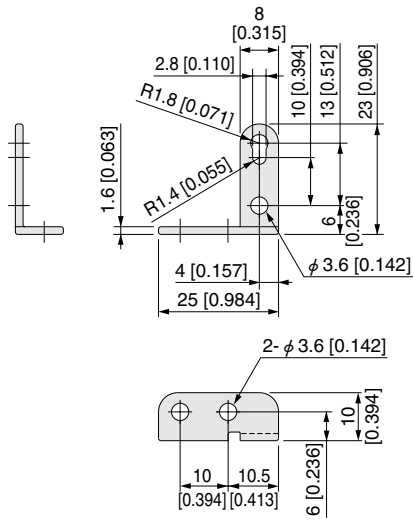

MV030-□

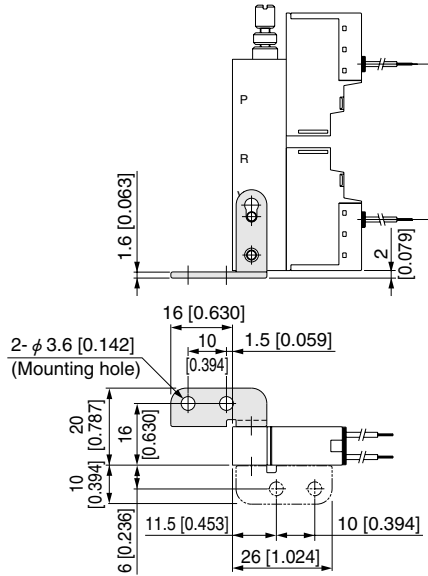

MV030-□-□-F

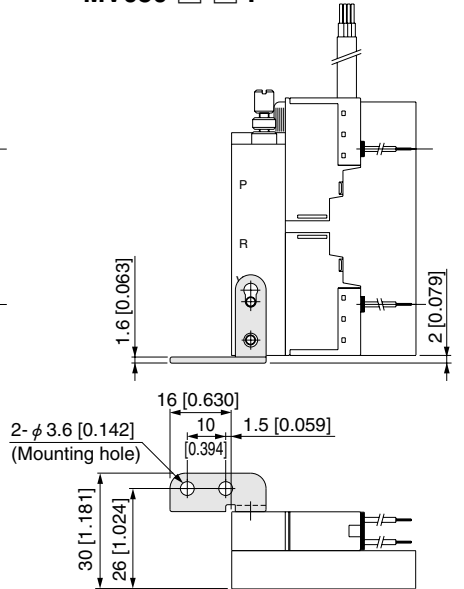

MV030M□A
MV030M□A-11

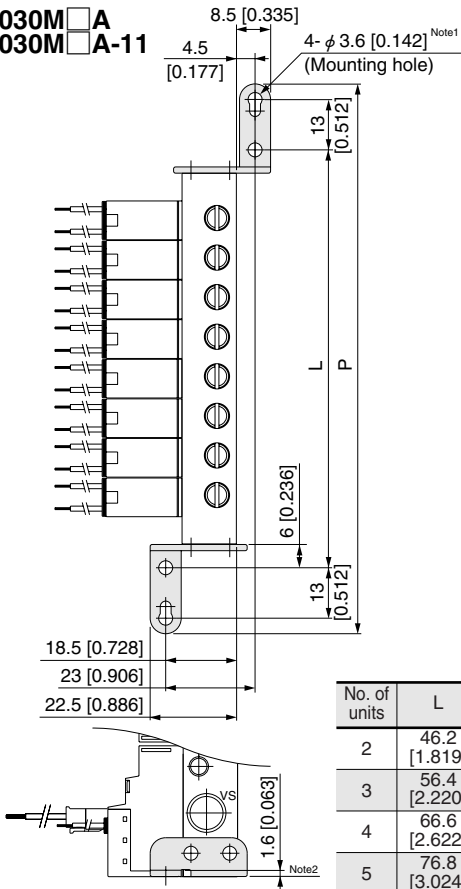

No. of units	L	P
2	46.2 [1.819]	80.2 [3.157]
3	56.4 [2.220]	90.4 [3.559]
4	66.6 [2.622]	100.6 [3.961]
5	76.8 [3.024]	110.8 [4.362]
6	87.0 [3.425]	121.0 [4.764]
7	97.2 [3.827]	131.2 [5.165]
8	107.4 [4.228]	141.4 [5.567]

MV030M□AS
MV030M□AS-11

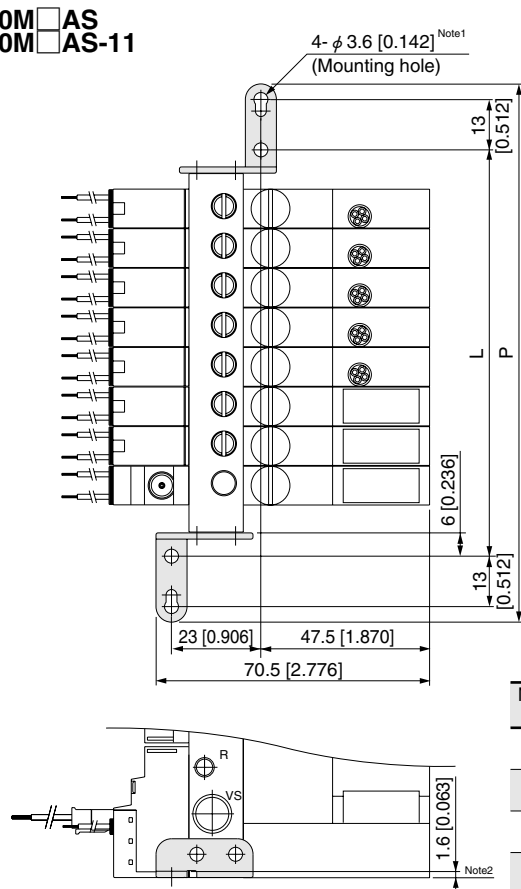

No. of units	L	P
2	43.2 [1.701]	77.2 [3.039]
3	53.4 [2.102]	87.4 [3.441]
4	63.6 [2.504]	97.6 [3.843]
5	73.8 [2.906]	107.8 [4.244]
6	84.0 [3.307]	118.0 [4.646]
7	94.2 [3.709]	128.2 [5.047]
8	104.4 [4.110]	138.4 [5.449]

Notes: 1. When using a mounting base for the manifold installation, use M3 screws to attach.
2. The bottom of the mounting base and the body are at the same level.

Notes: 1. When using a mounting base for the manifold installation, use M3 screws to attach.
2. The bottom of the mounting base and the body are at the same level.

Dimensions mm [in.]

● MV090-01

CAD MV090-01

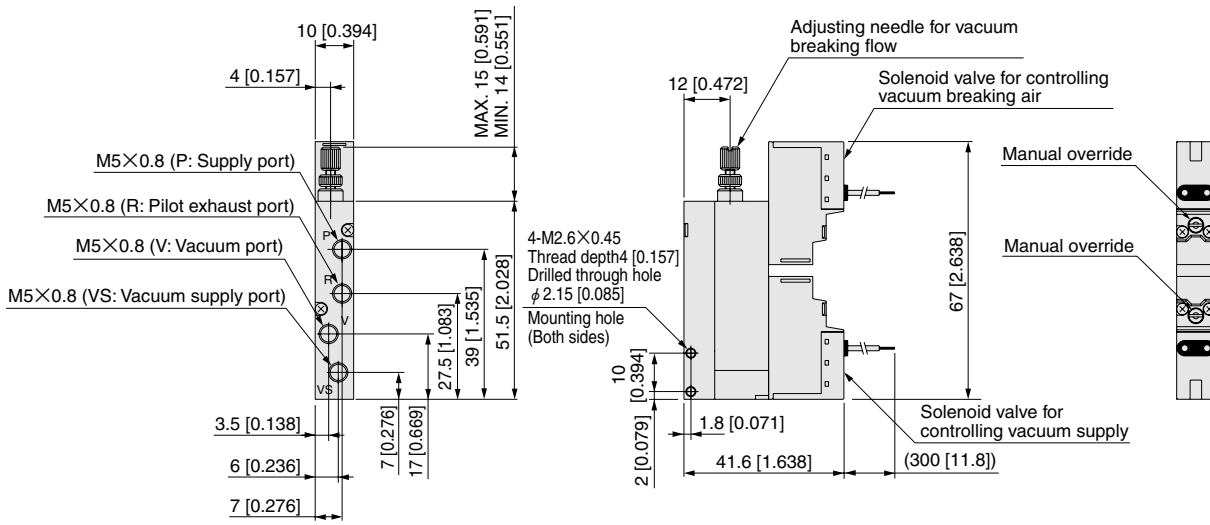

● MV090-02

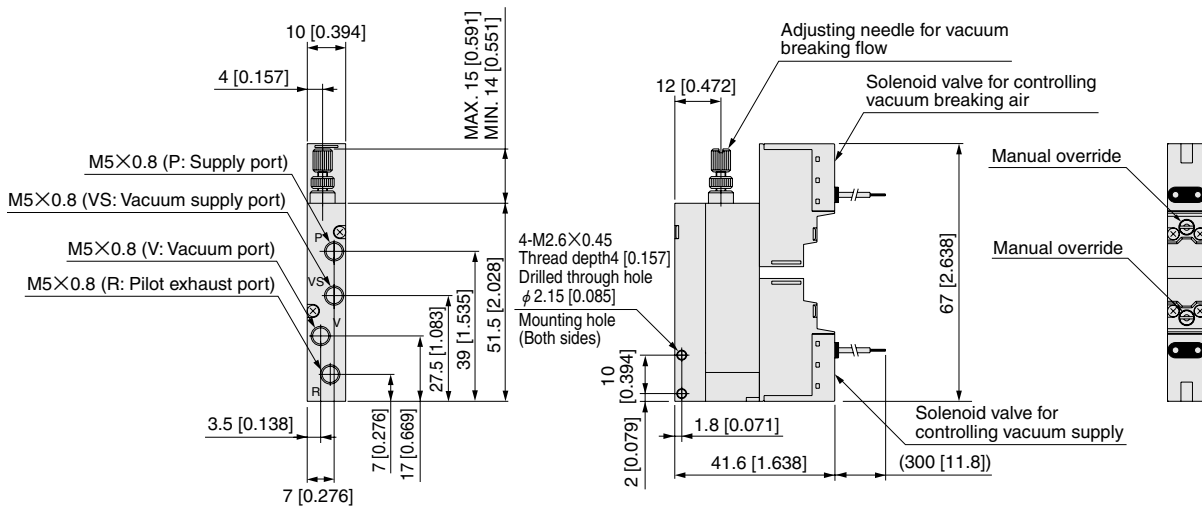

Option

● With wiring specification L connector (-PL, -ML)

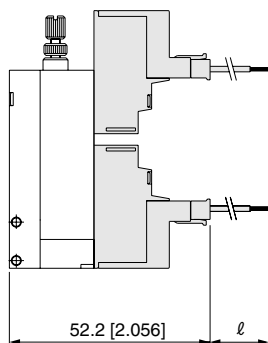

Model	Code	l
Blank		300 [11.8]
-1L		1000 [39.4]
-3L		3000 [118]

● MV090-03

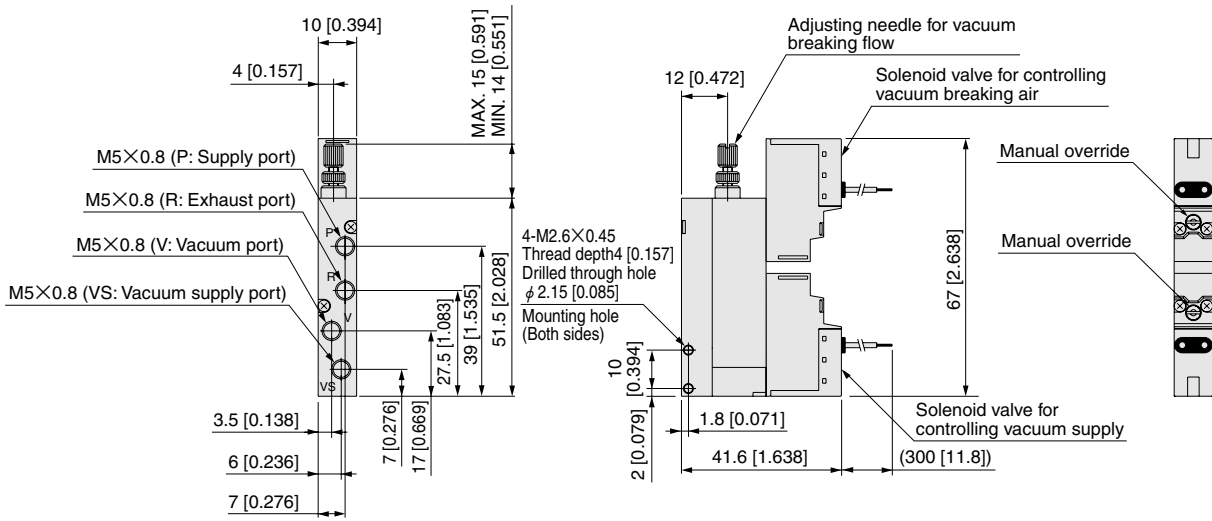

● MV090-04

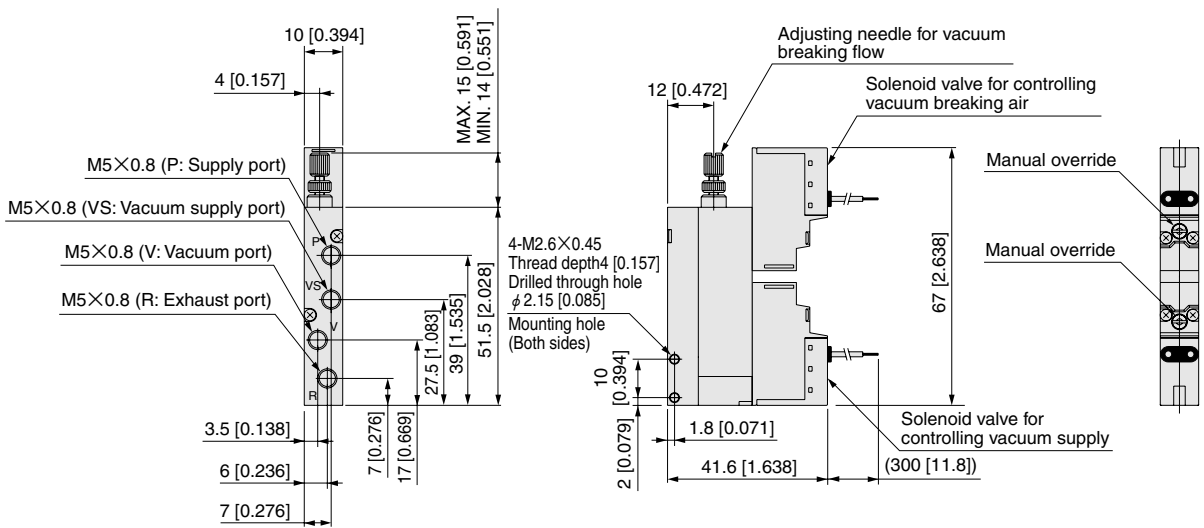

● MV090-01-□-F

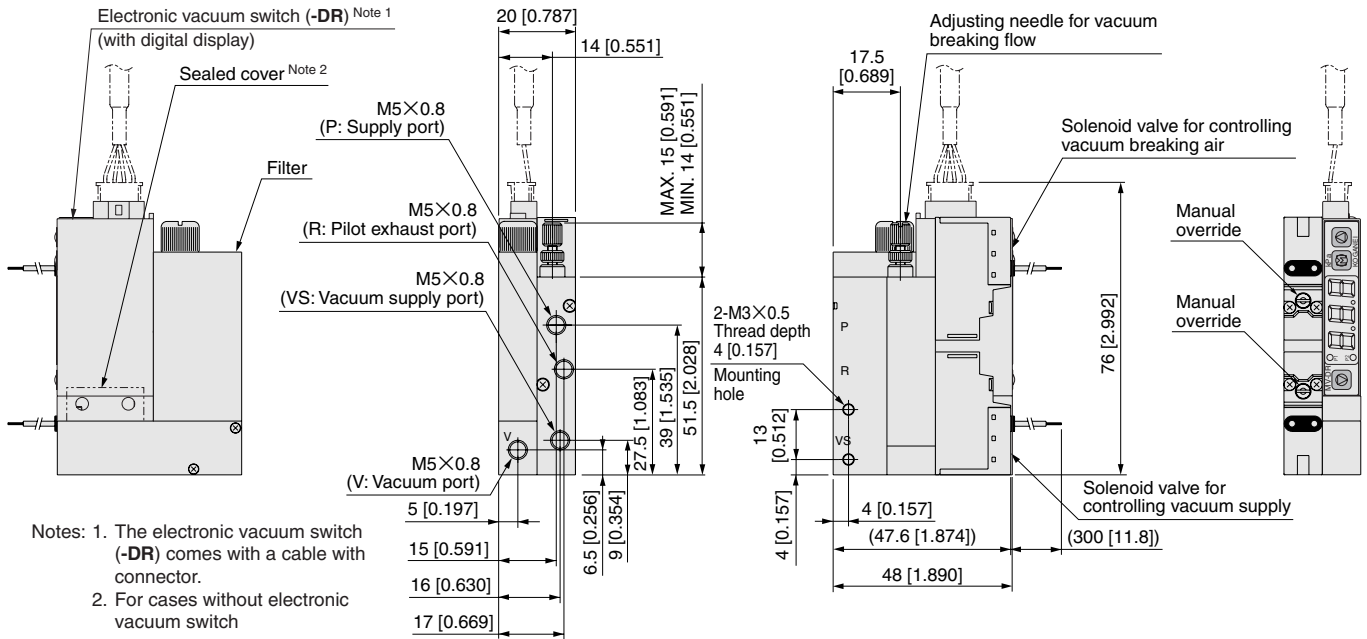

● MV090-02-□-F

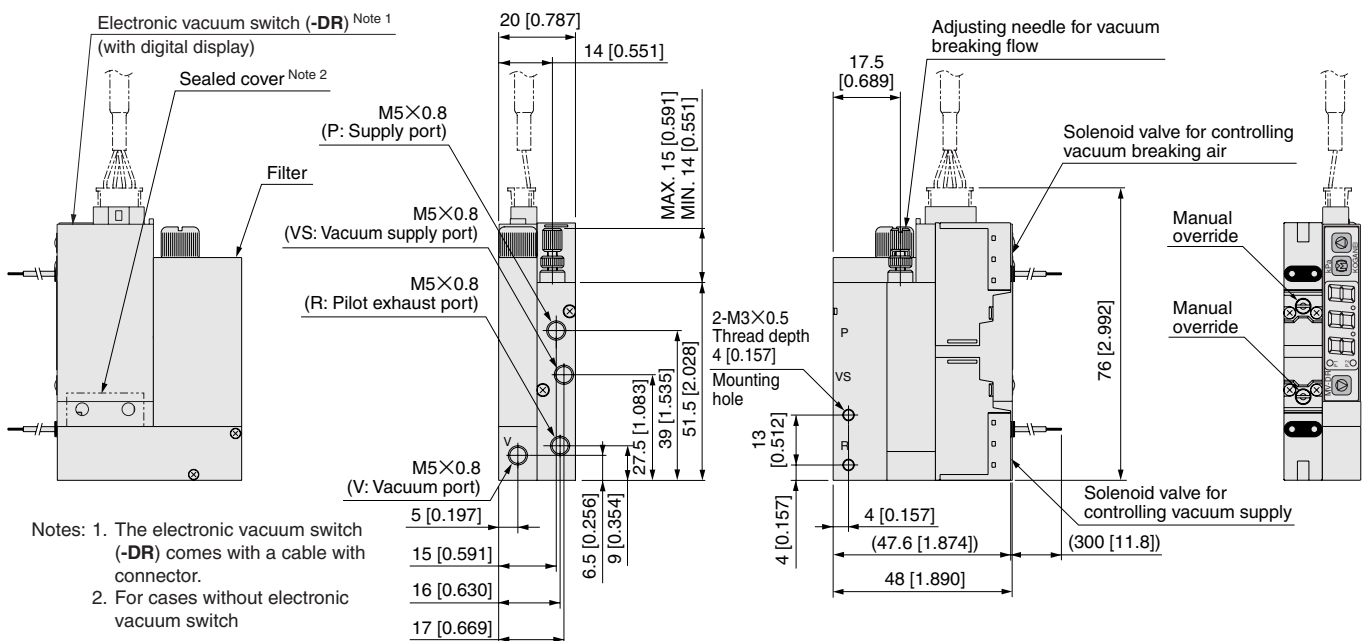

Option

● With L connector wiring specification (-PL, -ML)

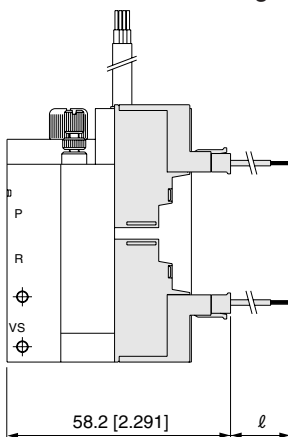

Model	Code	l
Blank		300 [11.8]
-1L		1000 [39.4]
-3L		3000 [118]

● Cable length of electronic vacuum switch (-DR)

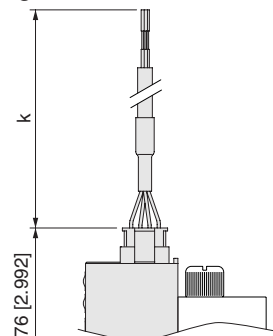

Model (wiring specifications and lead wire length)	Code	k
-PL-Blank, -PL-1L		1500 [59]
-ML-Blank, -ML-1L		1500 [59]
-PL-3L, -ML-3L		3000 [118]

● MV090-03-□-F

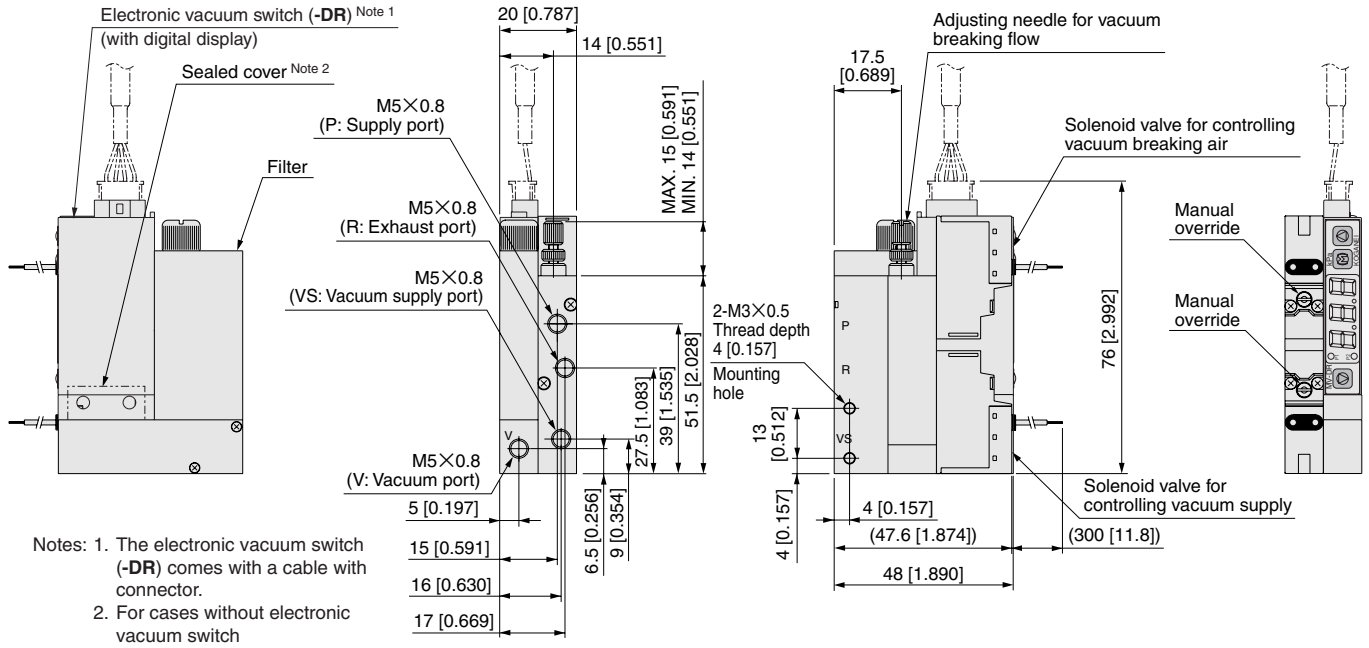

● MV090-04-□-F

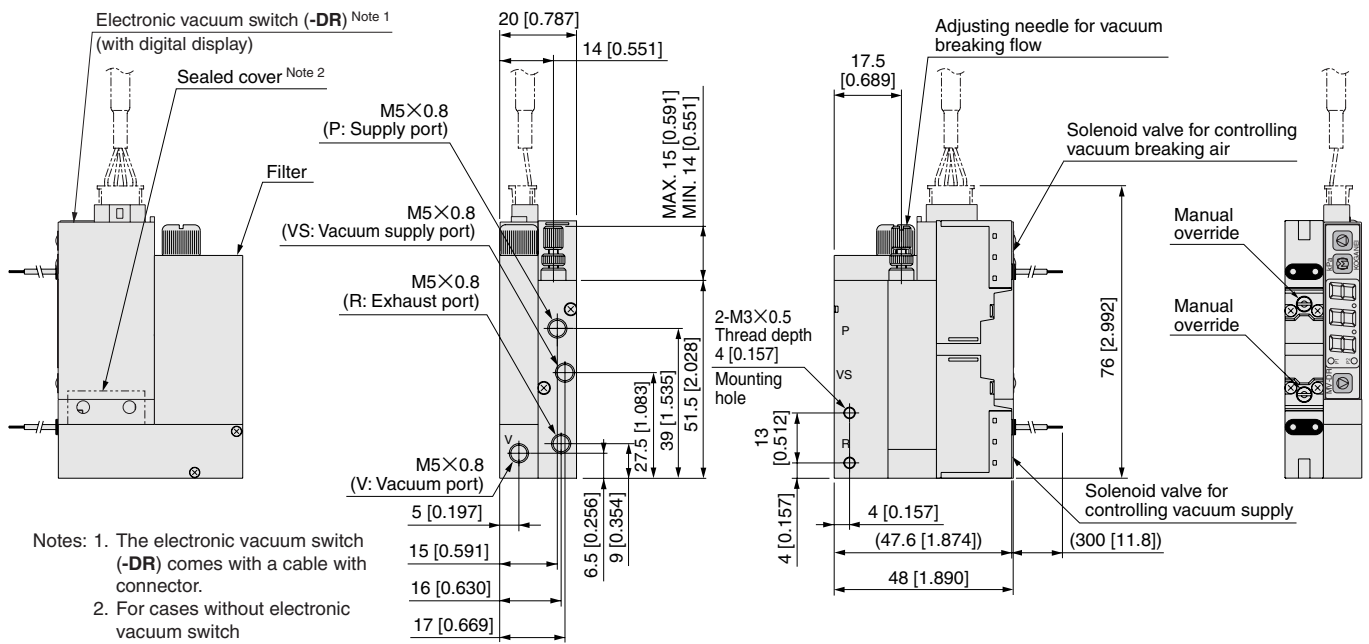

Option

● With electronic vacuum switch (-D, -DA)

Remark: Cable length available at 1500 mm [59 in.] only.

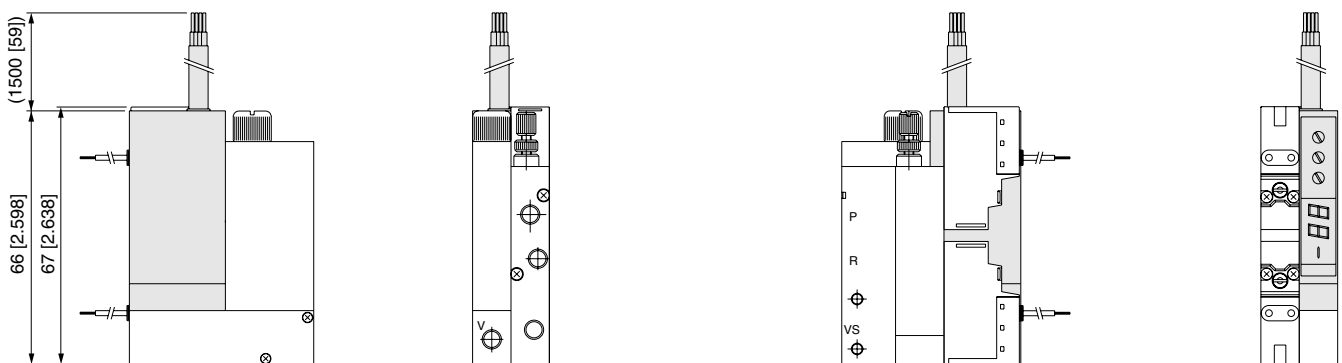

Dimensions mm [in.]

●MV090-05-□-F

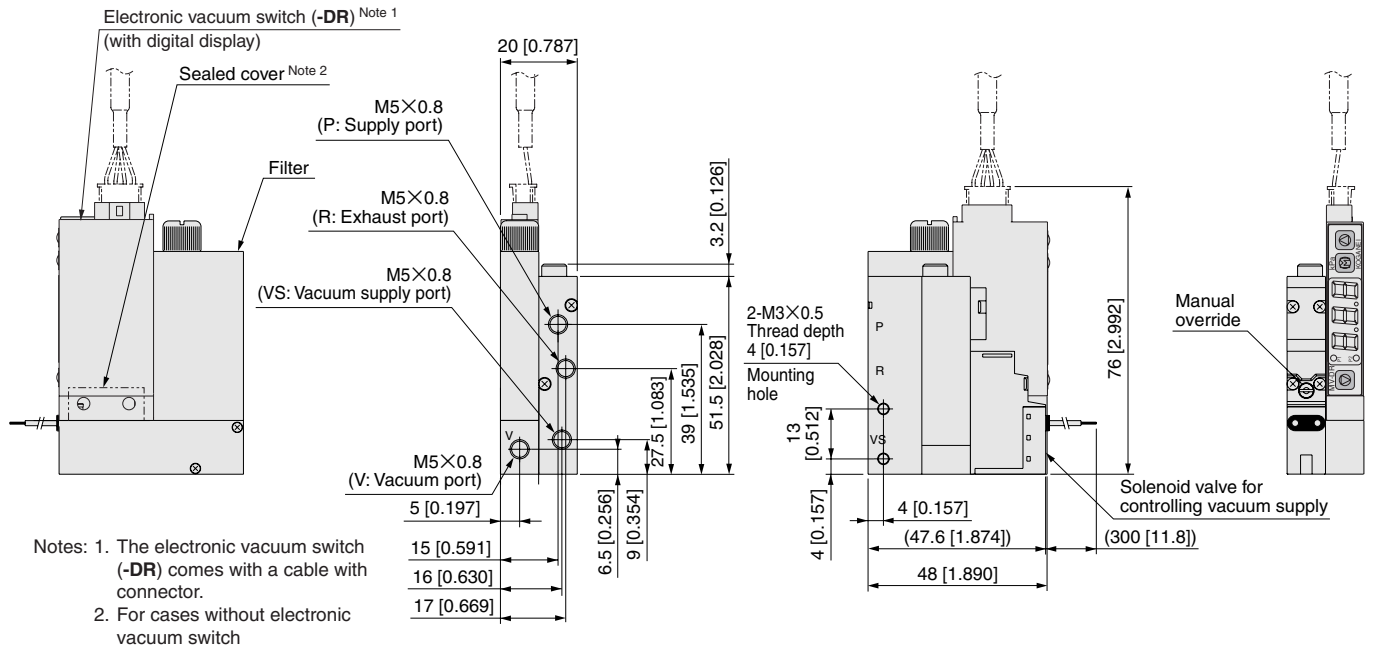

●MV090-06-□-F

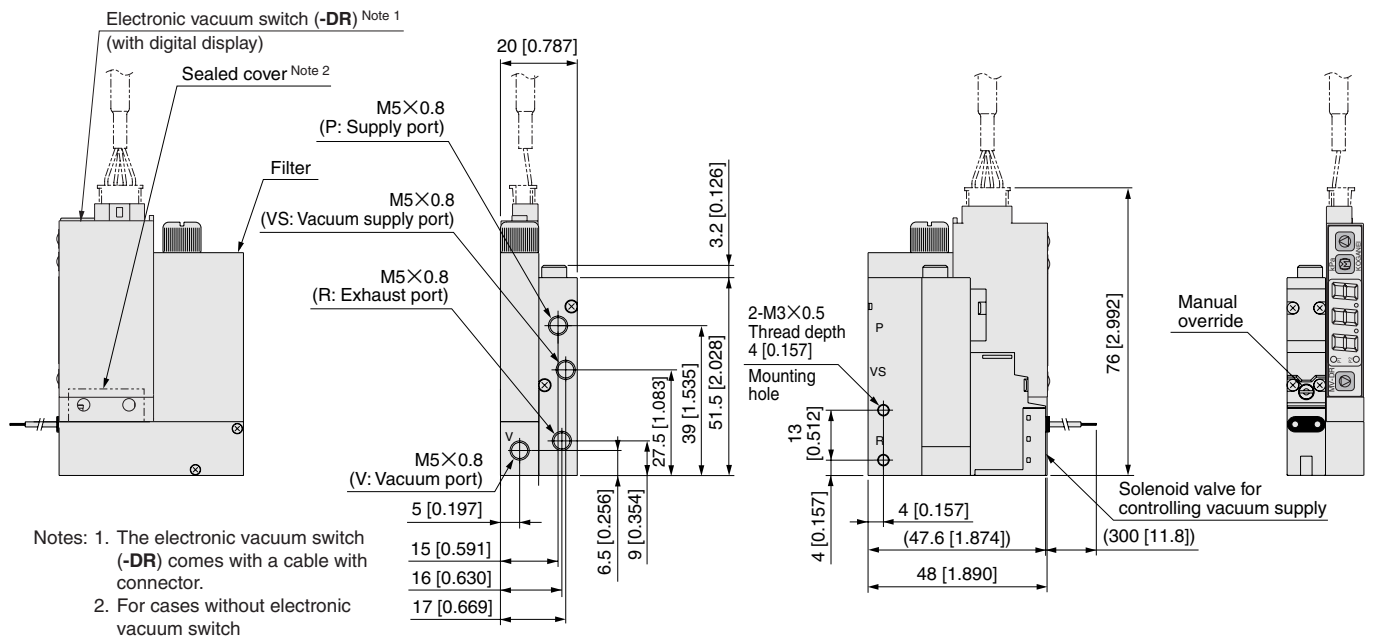

Option

●Pressure sensor (-EA, -ER)

Remark: Cable length available at 3000 mm [118 in.] only.

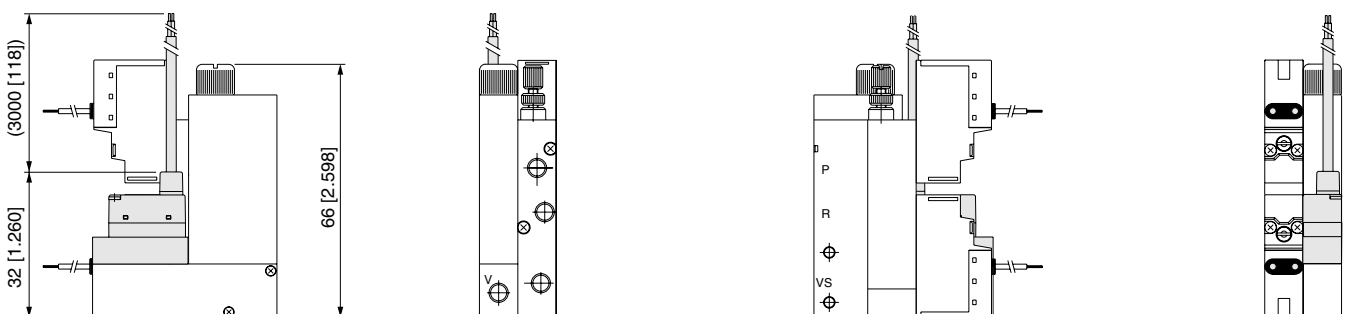

A type manifold

●MV090M8A

- stn.1,2 AMV090-01
- stn.3,4 AMV090-03
- stn.5,6 AMV090-01-PL
- stn.7,8 AMV090-03-PL

No. of units	L	P
2	—	26.8 [1.055]
3	—	37.0 [1.457]
4	10.4 [0.409]	47.2 [1.858]
5	20.6 [0.811]	57.4 [2.260]
6	30.8 [1.213]	67.6 [2.661]
7	41.0 [1.614]	77.8 [3.063]
8	51.2 [2.016]	88.0 [3.465]

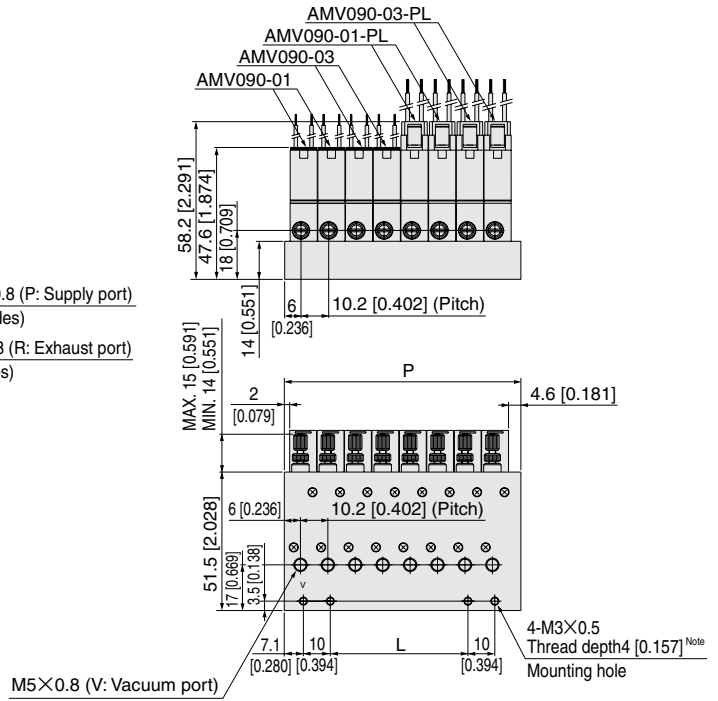
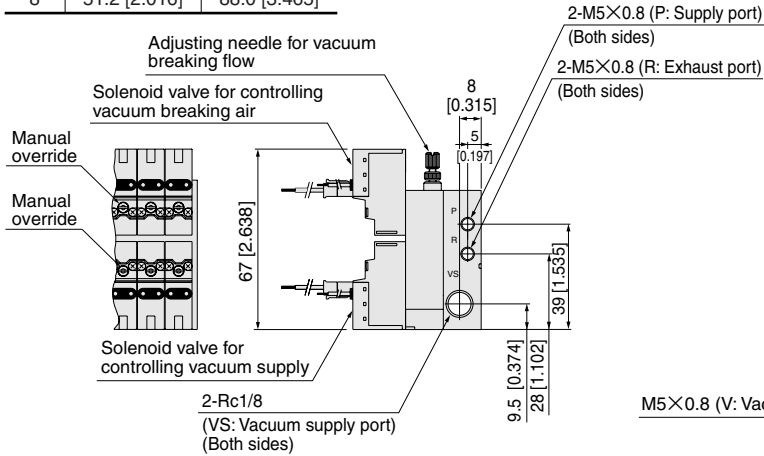

Note: 2- and 3-unit manifolds use 2-M3x0.5 thread depth 4 [0.157].

A type manifold

●MV090M8A-11

- stn.1,2 AMV090-02
- stn.3,4 AMV090-04
- stn.5,6 AMV090-02-PL
- stn.7,8 AMV090-04-PL

No. of units	L	P
2	—	26.8 [1.055]
3	—	37.0 [1.457]
4	10.4 [0.409]	47.2 [1.858]
5	20.6 [0.811]	57.4 [2.260]
6	30.8 [1.213]	67.6 [2.661]
7	41.0 [1.614]	77.8 [3.063]
8	51.2 [2.016]	88.0 [3.465]

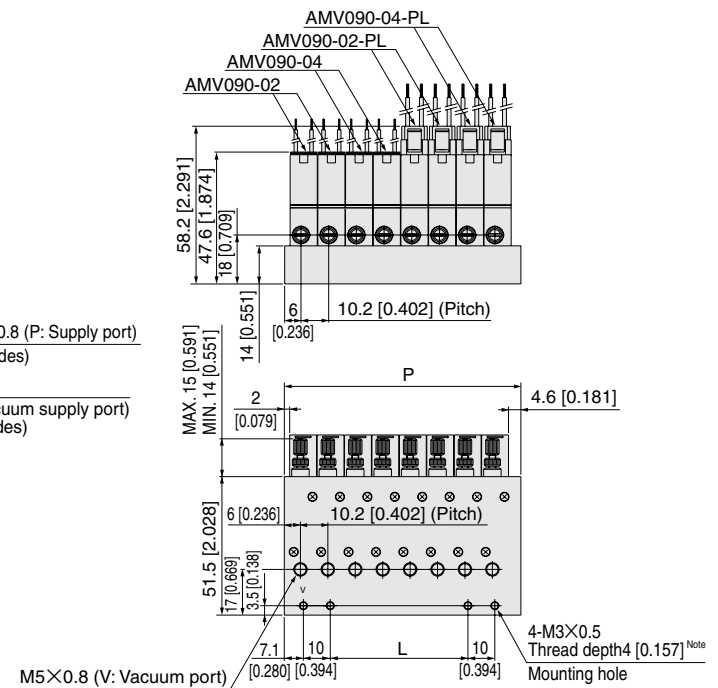
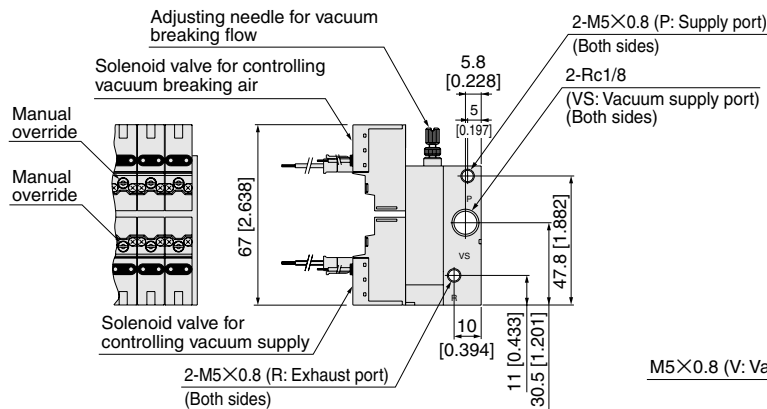

Note: 2- and 3-unit manifolds use 2-M3x0.5 thread depth 4 [0.157].

Remark: For the solenoid valve lead wire length, see the single unit dimensions on p.646.

AS type manifold (for mounting filter and vacuum switch)

●MV090M8AS

- stn.1 AMV090-05-F
- stn.2 AMV090-01-EA-F
- stn.3 AMV090-03-ER-F
- stn.4 AMV090-03-D-F
- stn.5,6 AMV090-01-DA-F-PL
- stn.7,8 AMV090-03-DR-F-PL

No. of units	L	P	M
2	20.2 [0.795]	34.2 [1.346]	29.2 [1.150]
3	30.4 [1.197]	44.4 [1.748]	39.4 [1.551]
4	40.6 [1.598]	54.6 [2.150]	49.6 [1.953]
5	50.8 [2.000]	64.8 [2.551]	59.8 [2.354]
6	61.0 [2.402]	75.0 [2.953]	70.0 [2.756]
7	71.2 [2.803]	85.2 [3.354]	80.2 [3.157]
8	81.4 [3.205]	95.4 [3.756]	90.4 [3.559]

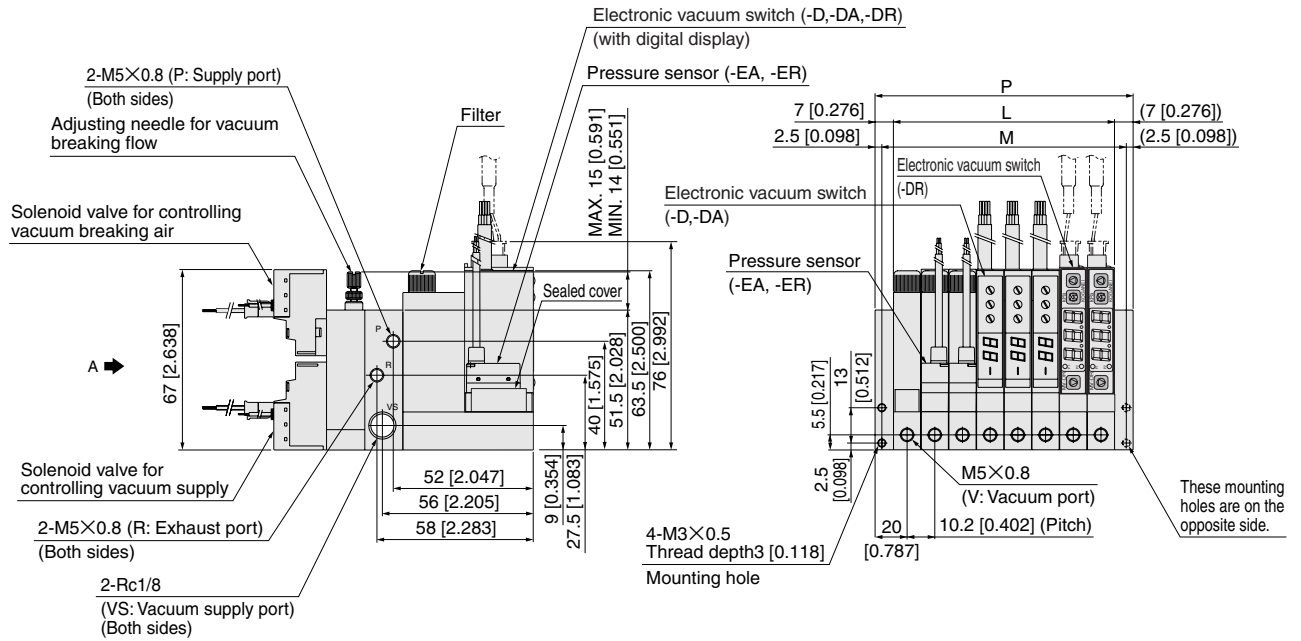
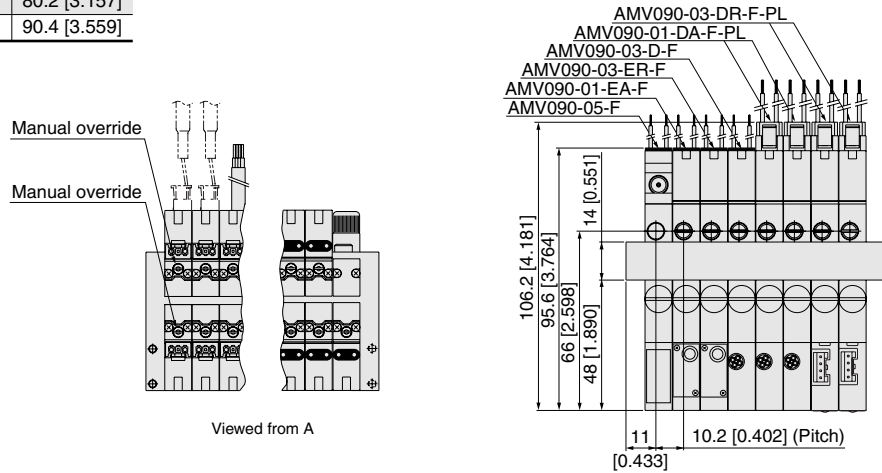

Remark: For the solenoid valve lead wire length, electronic vacuum switch, and pressure sensor cable length, see the single unit dimensions on p.648~650.

VACUUM VALVE UNITS

AS type manifold (for mounting filter and vacuum switch)

●MV090M8AS-11

- stn.1 AMV090-06-F
- stn.2 AMV090-02-EA-F
- stn.3 AMV090-04-ER-F
- stn.4 AMV090-04-D-F
- stn.5,6 AMV090-02-DA-F-PL
- stn.7,8 AMV090-04-DR-F-PL

No. of units	L	P	M
2	20.2 [0.795]	34.2 [1.346]	29.2 [1.150]
3	30.4 [1.197]	44.4 [1.748]	39.4 [1.551]
4	40.6 [1.598]	54.6 [2.150]	49.6 [1.953]
5	50.8 [2.000]	64.8 [2.551]	59.8 [2.354]
6	61.0 [2.402]	75.0 [2.953]	70.0 [2.756]
7	71.2 [2.803]	85.2 [3.354]	80.2 [3.157]
8	81.4 [3.205]	95.4 [3.756]	90.4 [3.559]

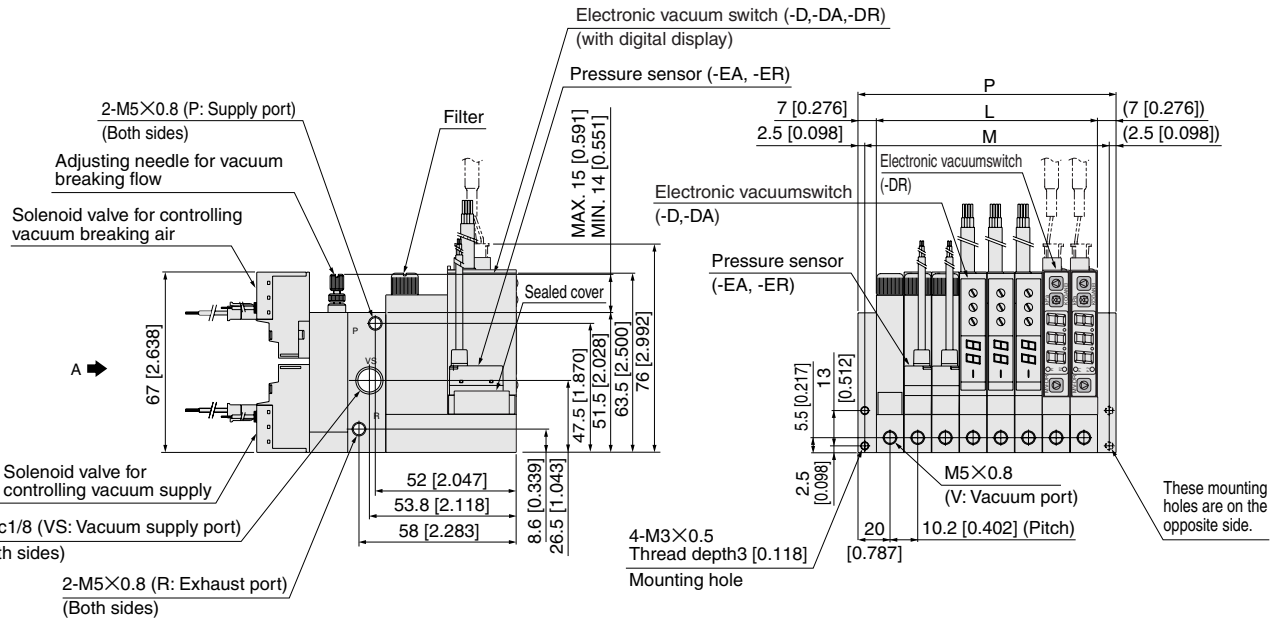
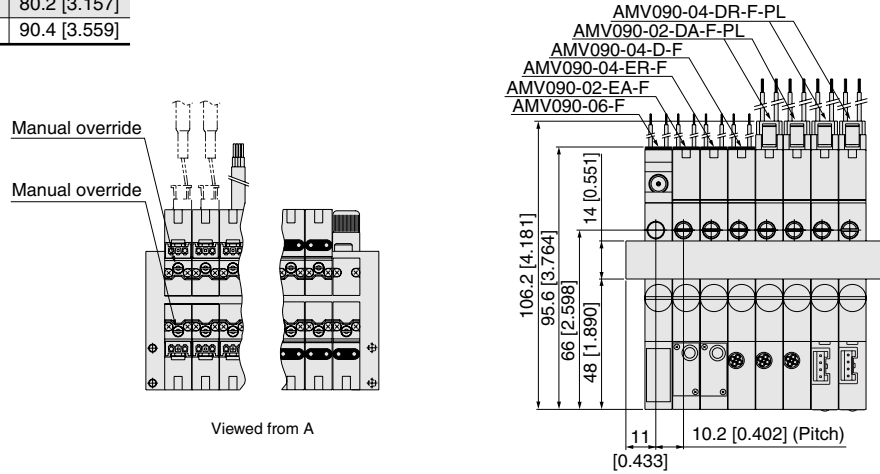

Remark: For the solenoid valve lead wire length, electronic vacuum switch, and pressure sensor cable length, see the single unit dimensions on p.648~650.

Dimensions mm [in.]

● Mounting base MV-21

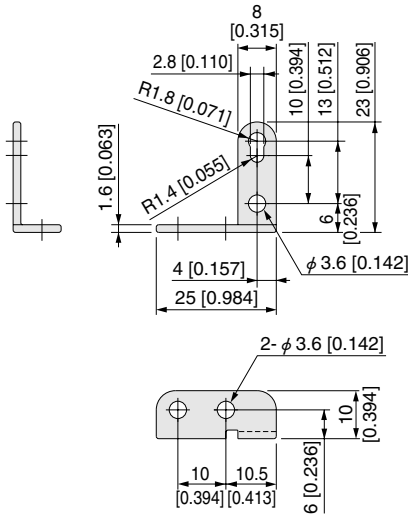

MV090-□

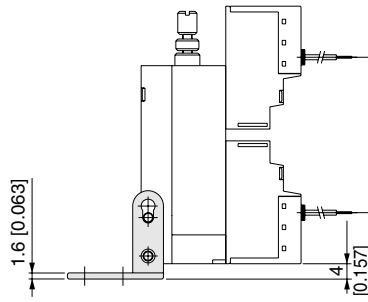

MV090-□-□-F

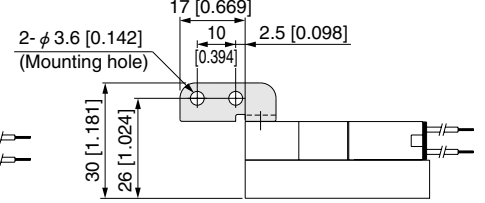
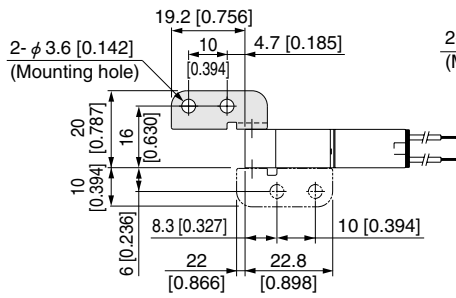
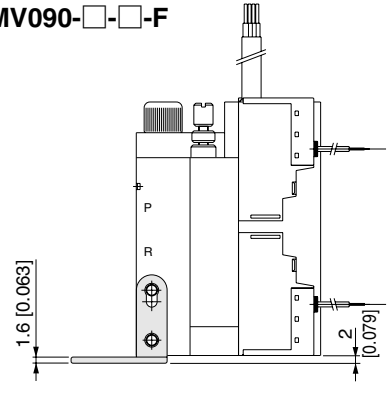

MV090M□A
MV090M□A-11

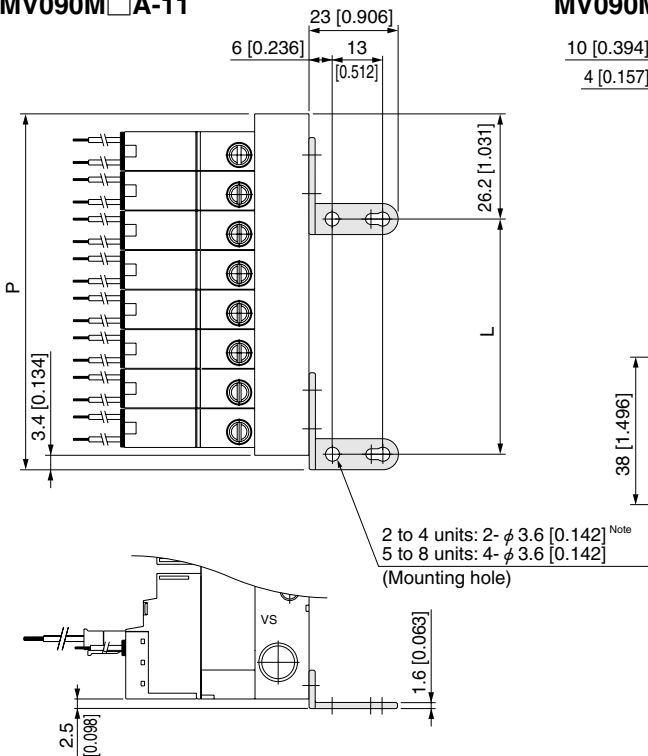

MV090M□AS
MV090M□AS-11

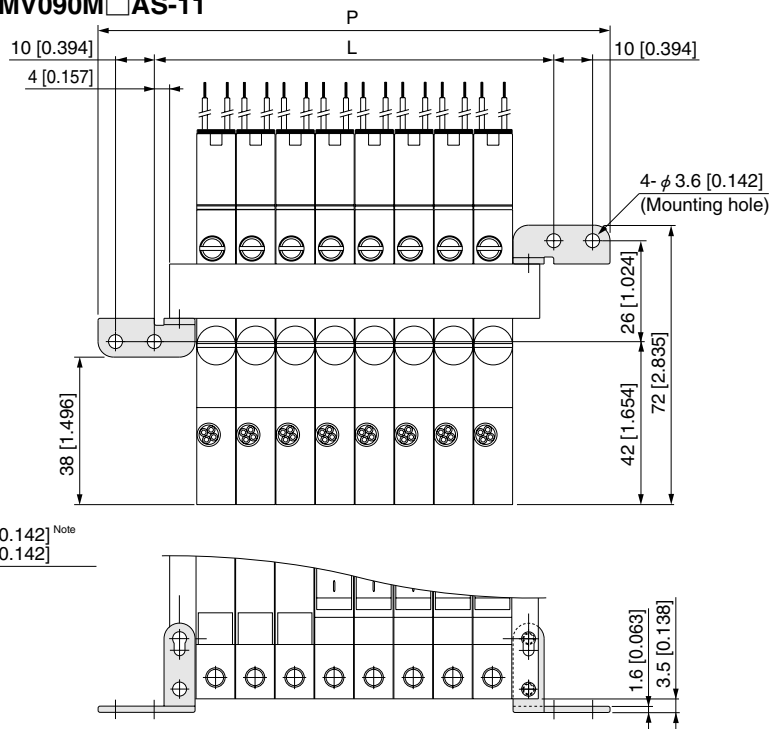

Note: When using a mounting base for the manifold installation, use M3 screws to attach. For the 2- to 4-unit manifolds, only one mounting base can be attached.

No. of units	L	P
2	—	30.2 [1.189]
3	—	40.4 [1.591]
4	—	50.6 [1.992]
5	30.6 [1.205]	60.8 [2.394]
6	40.8 [1.606]	71.0 [2.795]
7	51.0 [2.008]	81.2 [3.197]
8	61.2 [2.409]	91.4 [3.598]

Note: When using a mounting base for the manifold installation, use M3 screws to attach.

No. of units	L	P
2	42.2 [1.661]	71.2 [2.803]
3	52.4 [2.063]	81.4 [3.205]
4	62.6 [2.465]	91.6 [3.606]
5	72.8 [2.866]	101.8 [4.008]
6	83.0 [3.268]	112.0 [4.409]
7	93.2 [3.669]	122.2 [4.811]
8	103.4 [4.071]	132.4 [5.213]

VACUUM VALVE UNITS

MV180 (Large flow type)

Specifications

Basic model		MV180	
Item			
Media		Air	
Operating pressure range		-100~0 kPa [-29.54~0 in.Hg], 0.3~0.7 MPa [44~102 psi.]	
Proof pressure	MPa [psi.]	1.05 [152]	
Operating temperature range	°C [°F]	5~50 [41~122]	
Effective area (Positive pressure/vacuum)	mm ² [Cv]	2/4 [0.11/0.22]	
Lubrication		Prohibited	
Filtration	μm	30	
Mounting direction		Any	
Main valve specifications	Operation type	Indirect acting	
	Number of vacuum supply ports	2 or 3 ports	
	Valve function	Normally closed (NC)/Normally open (NO)	
	Shock resistance	m/s ² [G]	1373 [140] (axial direction 196 [20])
	Mounting valve		GA010LE1-2W

Vacuum side flow rate

Model	Suction flow rate ℓ/min [ft. ³ /min.] (A.N.R)	Remark
MV180-01 (03)	42 [1.48]	Single unit NC without filter
MV180-02 (04)	35 [1.24]	Single unit NO without filter
MV180-01 (03, 05) -F	35 [1.24]	Single unit NC with filter
MV180-02 (04, 06) -F	32 [1.13]	Single unit NO with filter
AMV180-01 (03, 05)	42 [1.48]	Manifold unit NC without filter
AMV180-02 (04, 06)	38 [1.34]	Manifold unit NO without filter
AMV180-01 (03, 05) -F	42 [1.48]	Manifold unit NC with filter
AMV180-02 (04, 06) -F	36 [1.27]	Manifold unit NO with filter

Measurement conditions

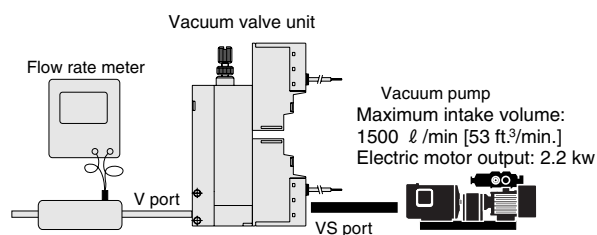

Solenoid specifications

Mounting solenoid valve model		GA010LE1-2W	
Item			
Rated voltage		DC24V	
Operating voltage range	V	21.6~26.4 (24±10%)	
Current (When rated voltage is applied)	Starting	mA	21
	Holding	mA	7
Power consumption	Starting	W	0.5
	Holding	W	0.17
Maximum allowable leakage current	mA	1	
Starting state time	ms	48	
Insulation resistance	MΩ	100 or more	
Wiring and lead wire length		Grommet type: 300 mm [11.8 in.], plug connector type: 300, 1000, 3000 mm [11.8, 39.4, 118 in.]	
Color of lead wire		Red (+), Black (-)	
Color of LED indicator		Red	
Surge suppression (as standard)		Flywheel diode	

Mounting solenoid valve

Model	Solenoid valve for controlling vacuum supply	Solenoid valve for controlling vacuum breaking air
(A) MV180-01	GA010LE1-2W	GA010LE1-2W
(A) MV180-02	GA010LE1-2W	GA010LE1-2W
(A) MV180-03	GA010LE1-2W	GA010LE1-2W
(A) MV180-04	GA010LE1-2W	GA010LE1-2W
(A) MV180-05	GA010LE1-2W	—
(A) MV180-06	GA010LE1-2W	—

Electronic Vacuum Switch Specifications

Item		Model	(A) MV180-□□-DR (MV-DR)	(A) MV180-□□-DA (MV-DA)	
		Type	Switch 2-output (variable hysteresis)	Switch 1-output (variable hysteresis+analog output)	
General	Pressure range		300~-100 kPa [43.5~-14.5 psi.]	0~-100 kPa [0~-29.54in.Hg]	
	Maximum pressure		600 kPa [87 psi.]	200 kPa [29 psi.]	
	Operating temperature		-10~60°C [14~140°F]		
	Operating ambient humidity		35~85%RH		
	Applicable media		Air or non-corrosive gas		
	Insulation resistance		100 MΩ MIN. (at DC500V megger)		
	Cable		Shielded 4-lead × 1500, 3000 mm [59, 118 in.]	Shielded 4-lead × 1500 mm [59 in.]	
Power supply	Voltage		DC12~24V±10%		
	Consumption current		35mA MAX.(24V, when output is ON)		
Switch output	Number of outputs		2	1	
	Output method		NPN open collector		
	Pressure setting method		Variable, with use of a trimmer		
	Pressure setting range		0~100% of rated pressure		
	Output display		When ON, operations indicator (LED) lights up.		
	Accuracy		±3% F.S. MAX. (Temperature range of 0~50°C [32~122°F], with 25°C [77°F] as a reference point)		
	Hysteresis		0 to 30 counts variable	Approximately 0~15% F.S., variable	
Analog output	Switch capacity		DC30V, 80 mA MAX.		
	Output voltage		1~5V		
	Zero-point voltage (VZERO)		1±0.1V		
	Span voltage (VSPAN)		4±0.1V		
	Temperature characteristics	VZERO	—	±0.1% F.S./°C (temperature range of 0~50°C [32~122°F], with 25°C [77°F] as a reference point)	
		VSPAN		±0.1% F.S./°C (temperature range of 0~50°C [32~122°F], with 25°C [77°F] as a reference point)	
	Output current		1mA MAX. (load resistance 5 kΩ or more)		
Linearity/hysteresis		±0.5% F.S.MAX.			
Environmental characteristics	Vibration resistance		98.1 m/s ² [10 G]		
	Shock resistance		196 m/s ² [20 G]		

Pressure sensor^{Note}

● Sensor head, coupled pressure sensor head

Item		Models	(A) MV180-□□-EA (MV-EA)	(A) MV180-□□-ER (MV-ER)	
		Type			
Media			Air or non-corrosive gas		
Power supply	Voltage		DC24V±10%		
	Power consumption		6 mA or less		
Analog output	Output voltage		1~5V		
	Zero-point voltage (VZERO)		1±0.05V	3.75±0.05V	
	Span voltage (VSPAN)		4.00±0.07V (reference value)		
	Temperature characteristics	VZERO		±30 mV or less (at 0~50°C [32~122°F])	
		VSPAN		±2%FS or less (at 0~50°C [32~122°F])	
Output current		1 mA MAX (load resistance 5 kΩ or more)			
General	Operating pressure range		0~-101.3 kPa [0~-29.92 in.Hg]	-100~220 kPa [-14.5~31.9 psi.]	
	Proof pressure		+900 kPa [130.5 psi.]		
	Operating temperature range		0~50°C [32~122°F], Storage -20~80°C [-4~176°F] (storage: humidity 65%RH or less, atmospheric pressure)		
	Operating humidity range		35~85%RH		
	Insulation resistance		100 MΩ MIN (at DC500V meggar)		
	Dielectric strength		AC500V, 1 minute		
	Cable		Oil-resistant, bend-resistant PCCV 0.15SQ×3 leads 3000 mm [118 in.]		

Note: The pressure sensor has analog output only. If switch output is required, a separate pressure sensor controller is necessary.
 We recommend the multi-channel pressure sensor controller (PSU-□). For details of the multi-channel pressure sensor controller, see p.780.

Mass

● Single unit

g [oz.]

Basic model	Body mass		Additional mass		
	-01, -02, -03, -04	-05, -06	Filter	Vacuum switch	Pressure sensor
			-F	-DR, -DA	-EA, -ER
MV180	65 [2.29]	52 [1.83]	28 [0.99]	50 [1.76]	34 [1.20]

Calculation sample For **MV180-03-F-DR**

$$= 65 + 28 + 50$$

$$= 143 \text{ g [5.04 oz.]}$$

● Manifold

g [oz.]

Basic model	Valve body mass		Additional mass		
	-01, -02, -03, -04	-05, -06	Filter	Vacuum switch	Pressure sensor
			-F	-DR, -DA	-EA, -ER
AMV180	55 [1.94]	43 [1.52]	20 [0.71]	50 [1.76]	34 [1.20]

● Manifold base

g [oz.]

Number of units		2 units	3 units	4 units	5 units	6 units	7 units	8 units
MV180M□A	Connecting rod	7.5 [0.265]	11 [[0.39]	13 [0.46]	16 [0.56]	19 [0.67]	22 [0.78]	25 [0.88]
	End block	50 [1.76]						

Calculation sample For **MV180M8A**, strn. 1~8 **AMV180-03-F-DR**

$$= 50 + 25 + (55 + 20 + 50) \times 8$$

$$= 1075 \text{ g [37.92 oz.]}$$

Symbols

MV180-01

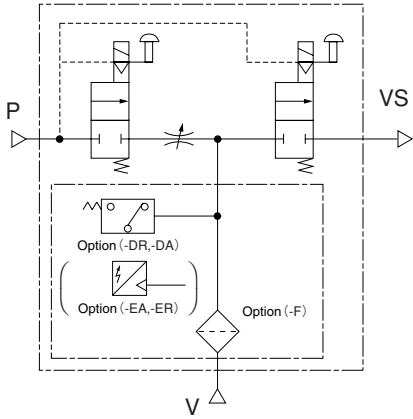

MV180-02

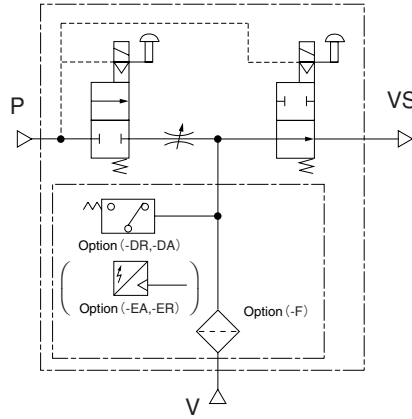

MV180-03

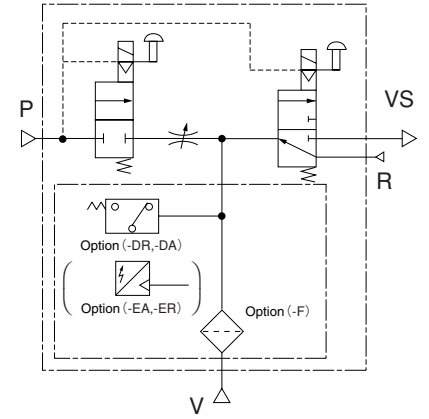

MV180-04

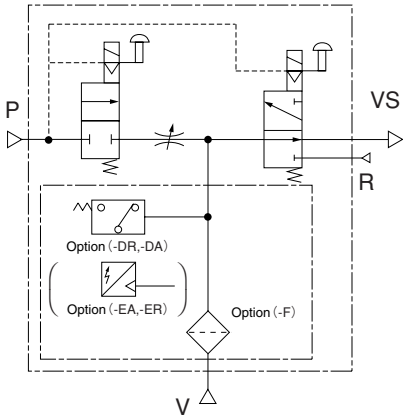

MV180-05

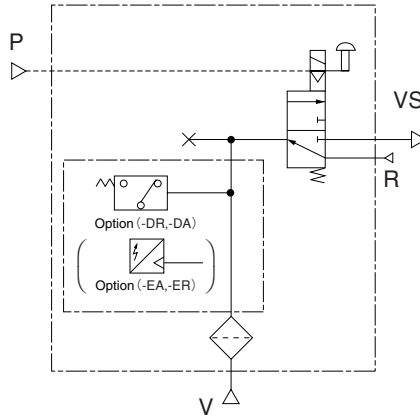

MV180-06

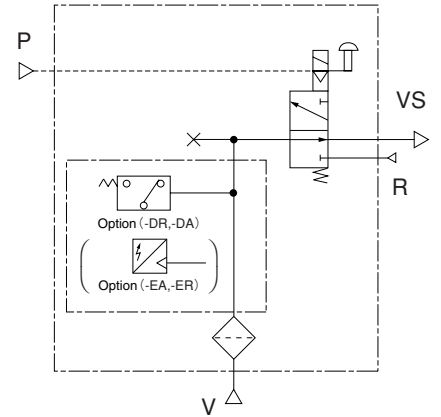

AMV180-01

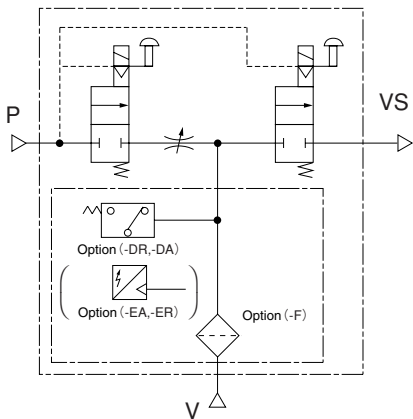

AMV180-02

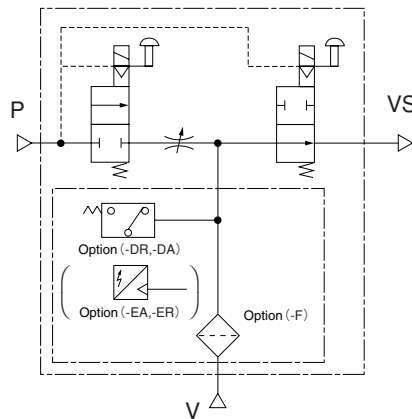

AMV180-03

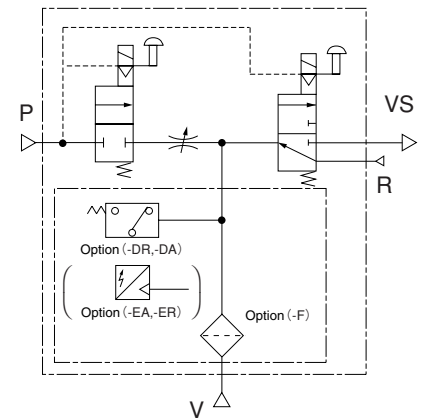

AMV180-04

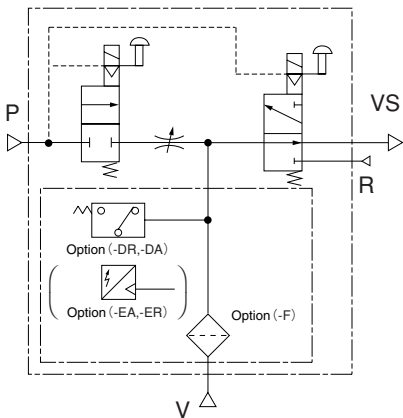

AMV180-05

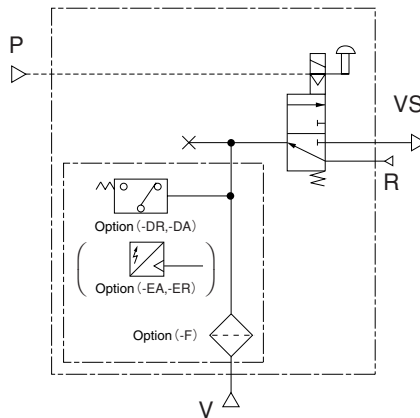

AMV180-06

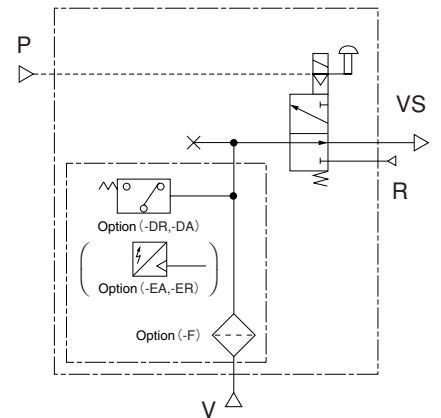

VACUUM VALVE UNITS

Note: In the manifold type, the P port, VS port, and R port are equipped to the manifold sharing each station.

Symbols

MV180-01B

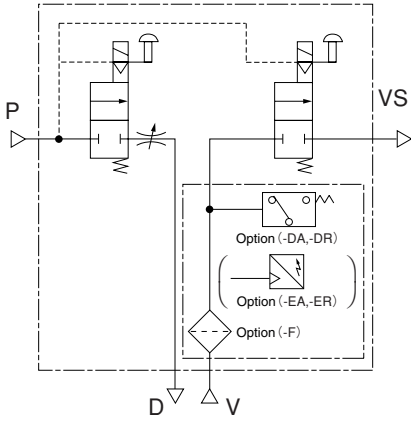

MV180-02B

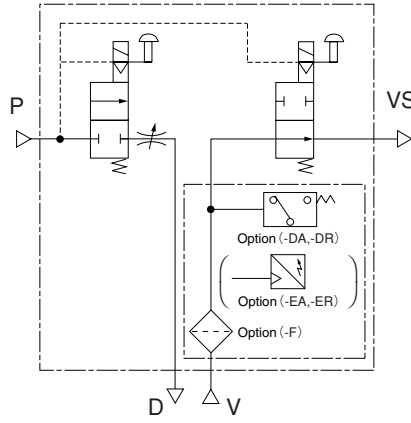

MV180-03B

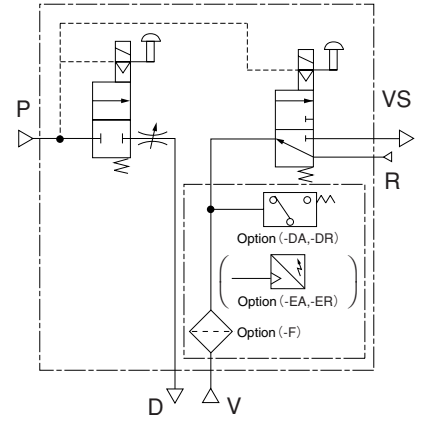

MV180-04B

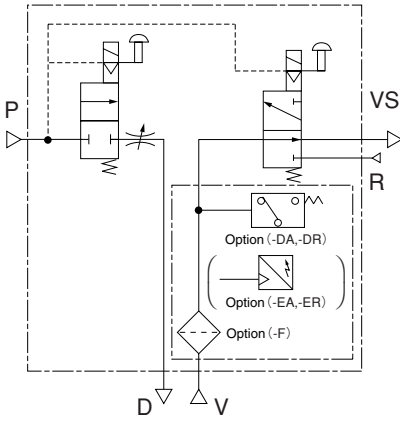

Single Unit Order Codes

Model

MV180

Effective area for vacuum supply 4.0 mm² [Cv=0.222]
(V→VS)

Valve unit configuration

-01

Vacuum supply control 2-way valve normally closed (NC)
Vacuum breaking air control 2-way valve normally closed (NC)

-02

Vacuum supply control 2-way valve normally open (NO)
Vacuum breaking air control 2-way valve normally closed (NC)

-03

Vacuum supply control 3-way valve normally closed (NC)
Vacuum breaking air control 2-way valve normally closed (NC)

-04

Vacuum supply control 3-way valve normally open (NO)
Vacuum breaking air control 2-way valve normally closed (NC)

-01B

Vacuum supply control 2-way valve normally closed (NC)
Vacuum breaking air control 2-way valve normally closed (NC)
Separate port for vacuum breaking air

-02B

Vacuum supply control 2-way valve normally open (NO)
Vacuum breaking air control 2-way valve normally closed (NC)
Separate port for vacuum breaking air

-03B

Vacuum supply control 3-way valve normally closed (NC)
Vacuum breaking air control 2-way valve normally closed (NC)
Separate port for vacuum breaking air

-04B

Vacuum supply control 3-way valve normally open (NO)
Vacuum breaking air control 2-way valve normally closed (NC)
Separate port for vacuum breaking air

-05

Vacuum supply control 3-way valve normally closed (NC)
Without vacuum breaking air control valve

-06

Vacuum supply control 3-way valve normally open (NO)
Without vacuum breaking air control valve

Electronic vacuum switch

Blank

No vacuum switch

-DR

With vacuum switch 2-output variable hysteresis type

-DA

With vacuum switch 1-output variable hysteresis type (with analog output)

(Pressure sensor ^{Note})

-EA

For negative pressure

(Pressure sensor ^{Note})

-ER

For coupled pressure

Filter

Blank

No filter

-F

With filter

Wiring specification

Blank

Grommet (with LED indicator)

-PL

L connector, positive common (with LED indicator)

-ML

L connector, negative common (with LED indicator)

Lead wire length

Blank

300 mm [11.8 in.]

-1L

1000 mm [39.4 in.]

-3L

3000 mm [118 in.]

Model	Valve unit configuration	Electronic Vacuum Switch (Pressure sensor)	Filter	Wiring specification	Lead wire length	Voltage
MV180	-01, -01B -02, -02B -03, -03B -04, -04B	Blank	Blank	Blank	Blank	DC24V
				-PL	Blank	
		-ML	-1L			
		-3L	-3L			
	-DR -DA -EA ^{Note} -ER ^{Note}	-F	Blank	Blank		
			-PL	Blank		
-ML	-1L					
-3L	-3L					
-05 -06	Blank -DR -DA -EA ^{Note} -ER ^{Note}	-F	Blank	Blank		
			-PL	Blank		
-ML	-1L					
-3L	-3L					

Note: The pressure sensor has analog output only. If switch output is required, a separate pressure sensor controller is necessary. We recommend the multi-channel pressure sensor controller (PSU-□). For details of the multi-channel pressure sensor controller, see p.780.

Additional parts (to be ordered separately)

●Electronic vacuum switch (with digital display)

MV —

Switch specification

- D : Switch 2-output fixed hysteresis type
- DR : Switch 2-output variable hysteresis type
- DA : Switch 1-output variable hysteresis type (with analog output)

●Pressure sensor

MV —

Pressure specification

- EA : Negative pressure
- ER : Coupled pressure

●Mounting base

MV — 21



●Filter for replacement

MV — F

(element only, 5 pcs.)

Dimensions mm [in.]

● **MV180-01**

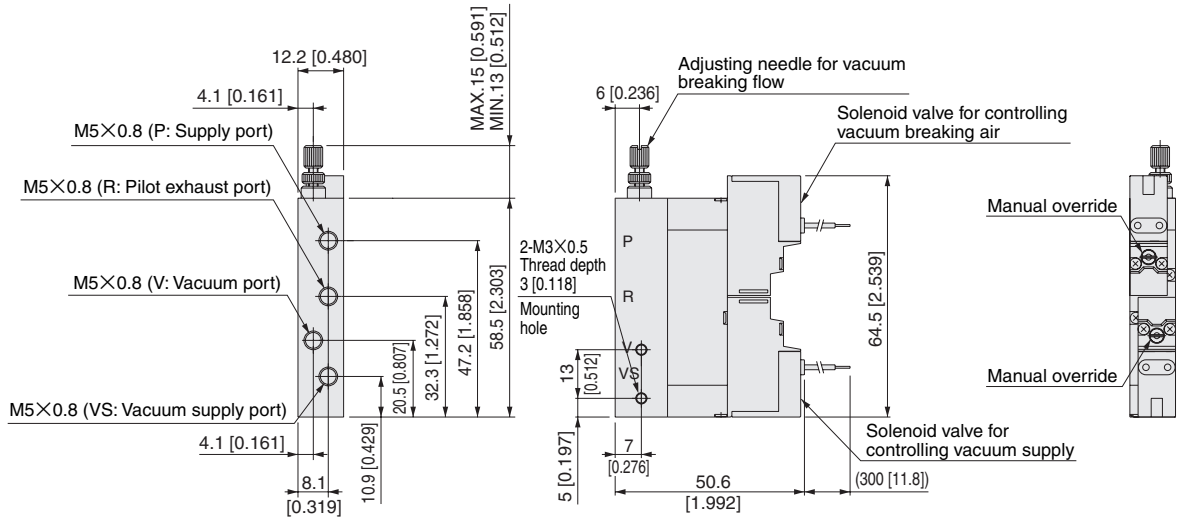

● **MV180-02**

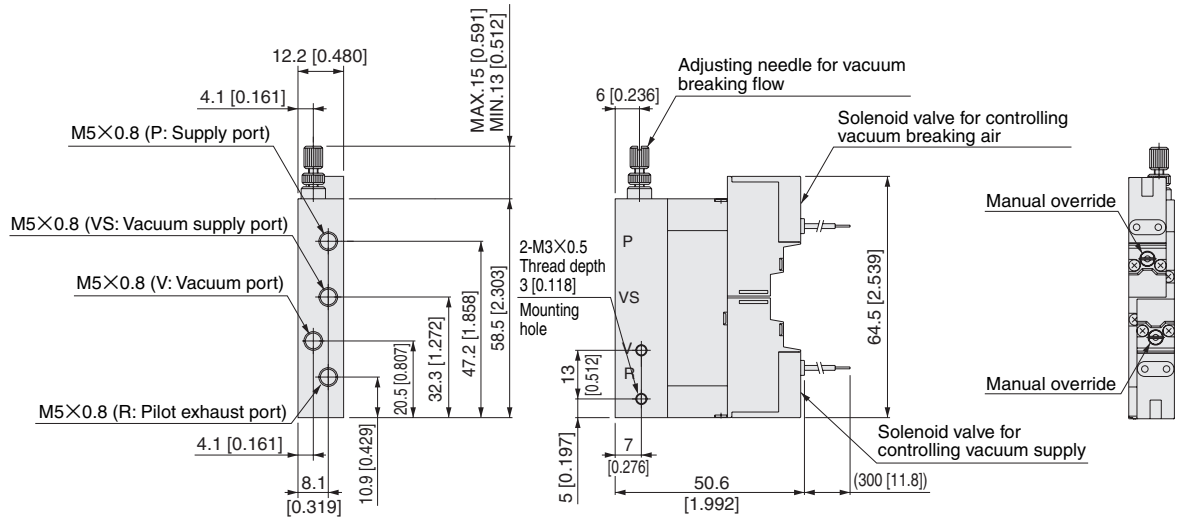

Option

● With wiring specification L connector (-PL, -ML)

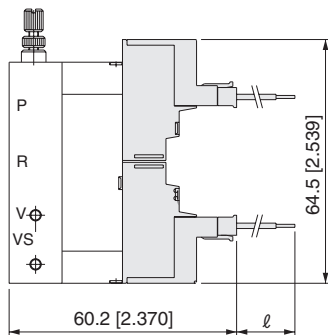

Model	Code	l
Blank		300 [11.8]
-1L		1000 [39.4]
-3L		3000 [118]

●MV180-03

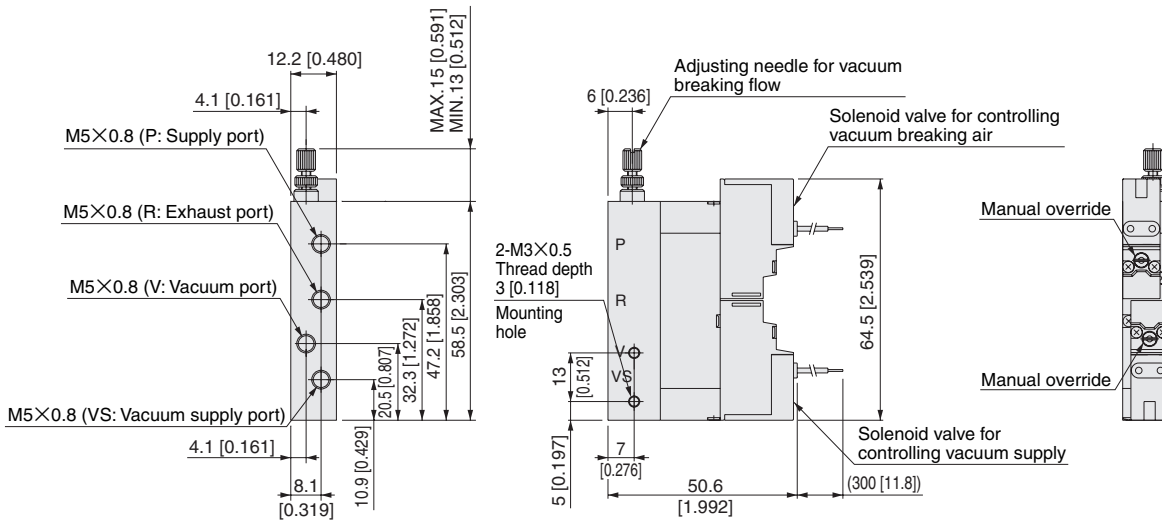

●MV180-04

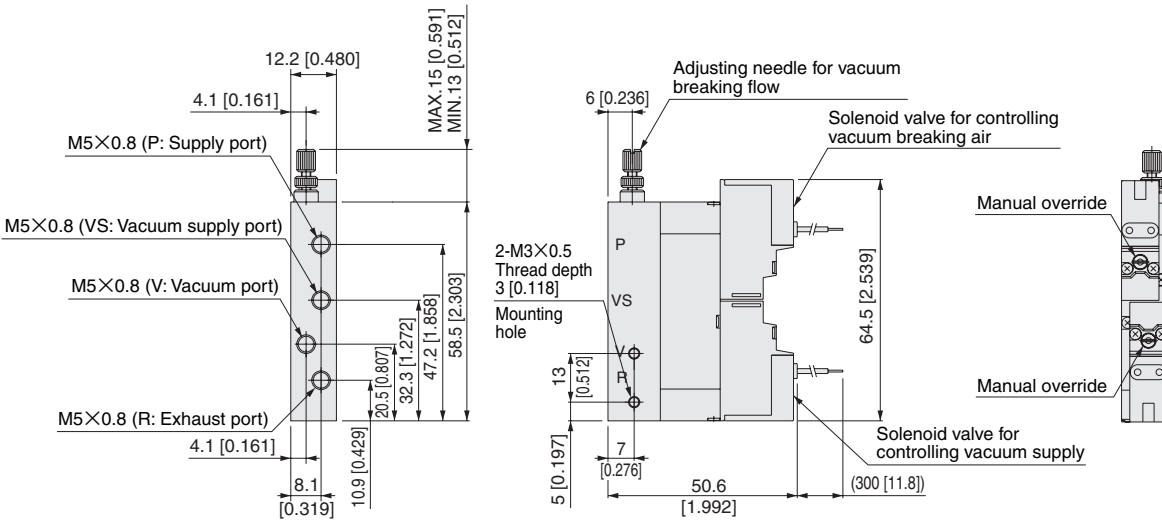

Dimensions mm [in.]

●MV180-01-DR-F

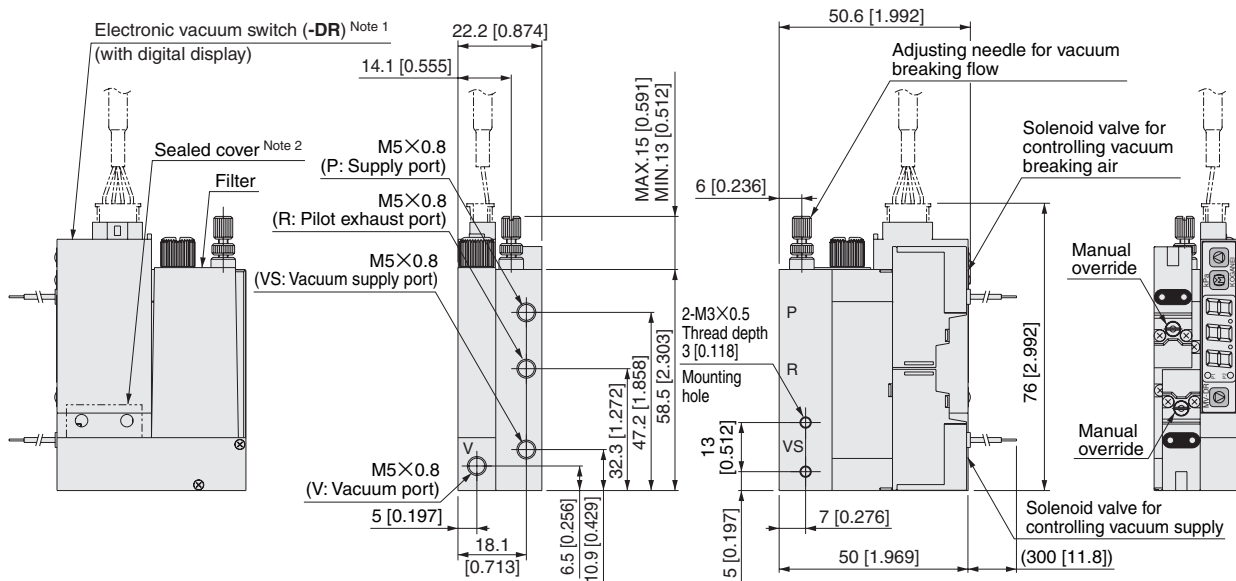

Notes: 1. The electronic vacuum switch (-DR) comes with a cable with connector.
2. For cases without electronic vacuum switch

●MV180-02-DR-F

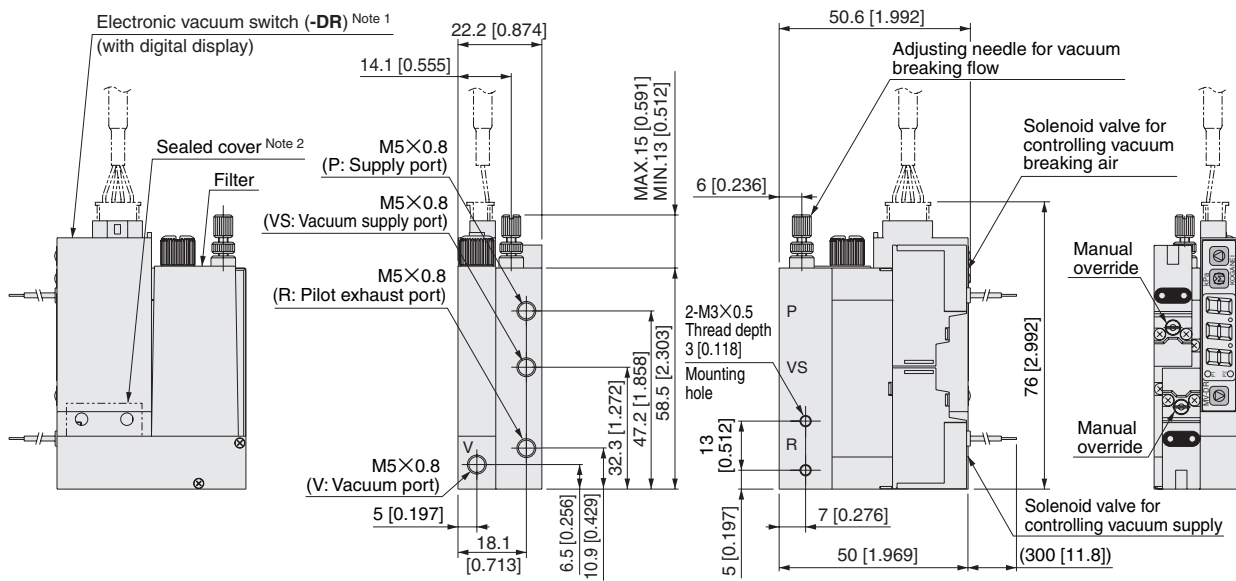

Notes: 1. The electronic vacuum switch (-DR) comes with a cable with connector.
2. For cases without electronic vacuum switch

Option

●With L connector wiring specification (-PL, -ML)

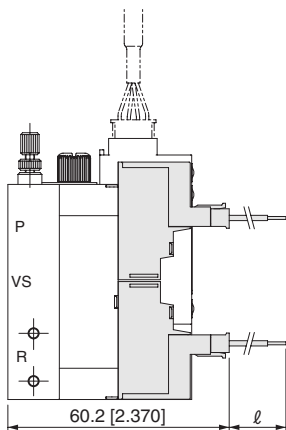

Model	Code	l
Blank		300 [11.8]
-1L		1000 [39.4]
-3L		3000 [118]

●Cable length of electronic vacuum switch (-DR)

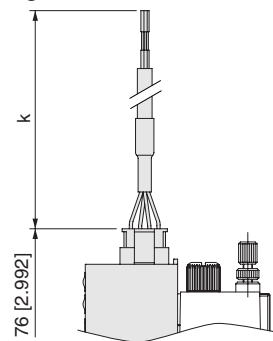

Model (wiring specifications and lead wire length)	Code	k
-PL-Blank, -PL-1L		1500 [59]
-ML-Blank, -ML-1L		1500 [59]
-PL-3L, -ML-3L		3000 [118]

●MV180-03-DR-F

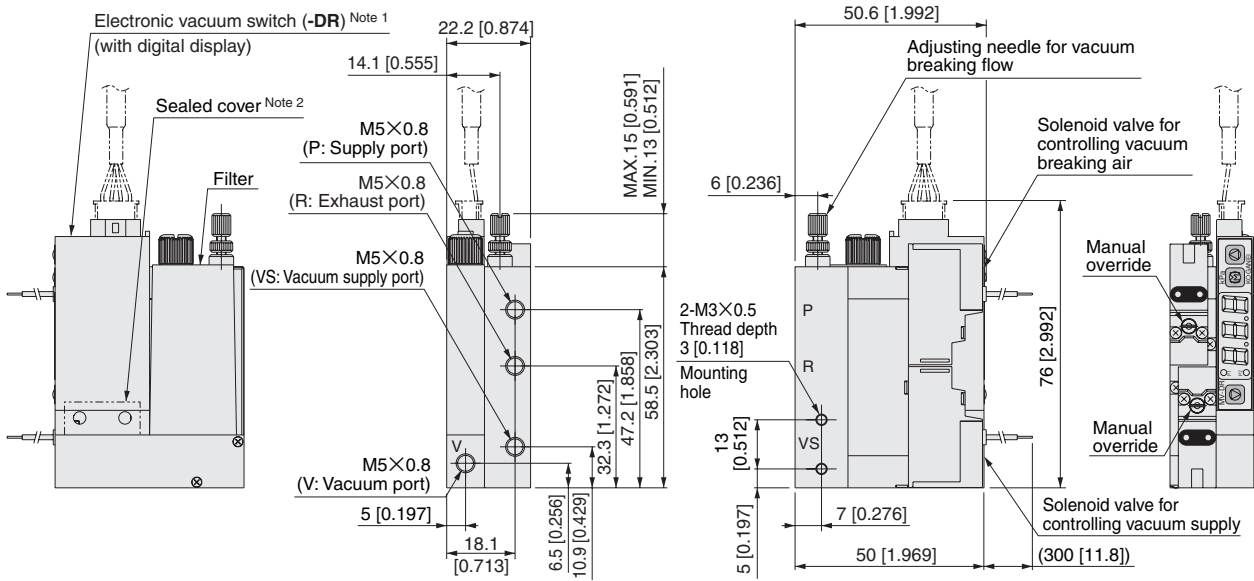

Notes: 1. The electronic vacuum switch (-DR) comes with a cable with connector.
2. For cases without electronic vacuum switch

●MV180-04-DR-F

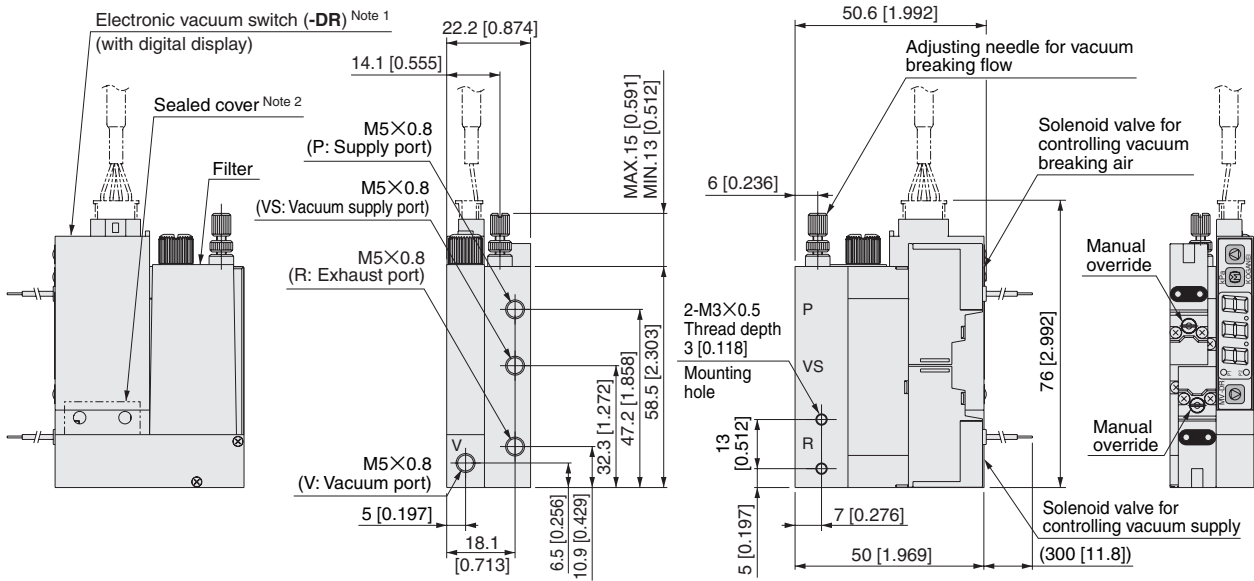

Notes: 1. The electronic vacuum switch (-DR) comes with a cable with connector.
2. For cases without electronic vacuum switch

Option

●With electronic vacuum switch (-DA)

Remark: Cable length available at 1500 mm [59 in.] only.

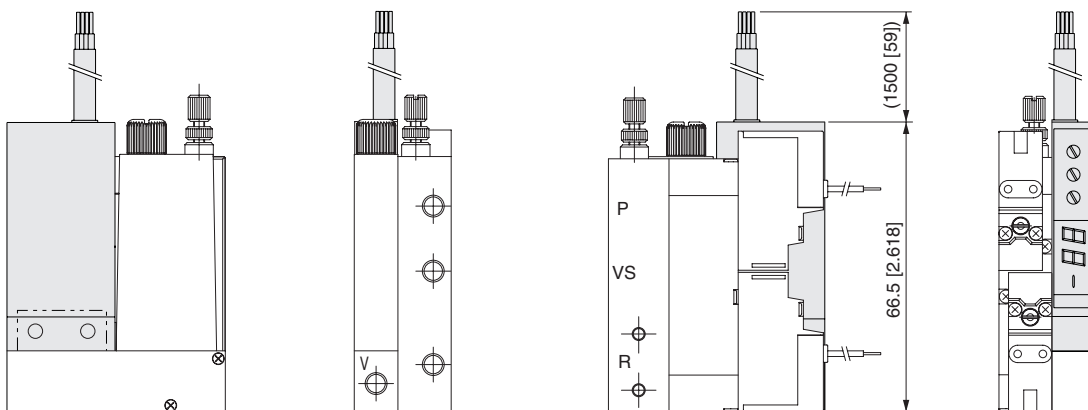

Dimensions mm [in.]

●MV180-05-DR-F

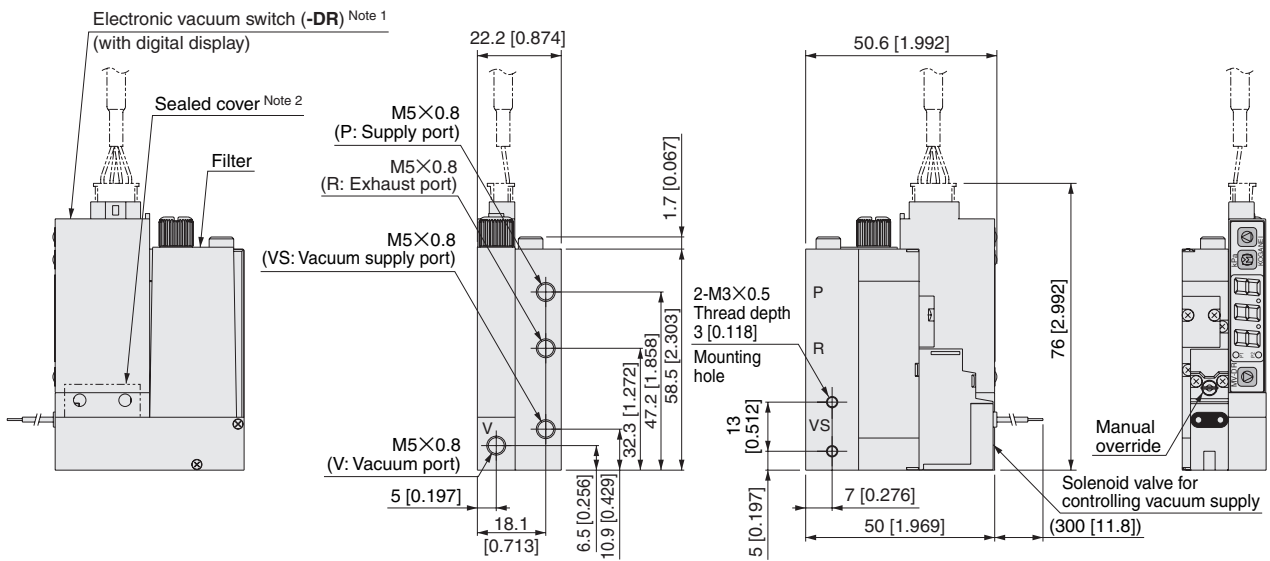

Notes: 1. The electronic vacuum switch (-DR) comes with a cable with connector.
2. For cases without electronic vacuum switch

●MV180-06-DR-F

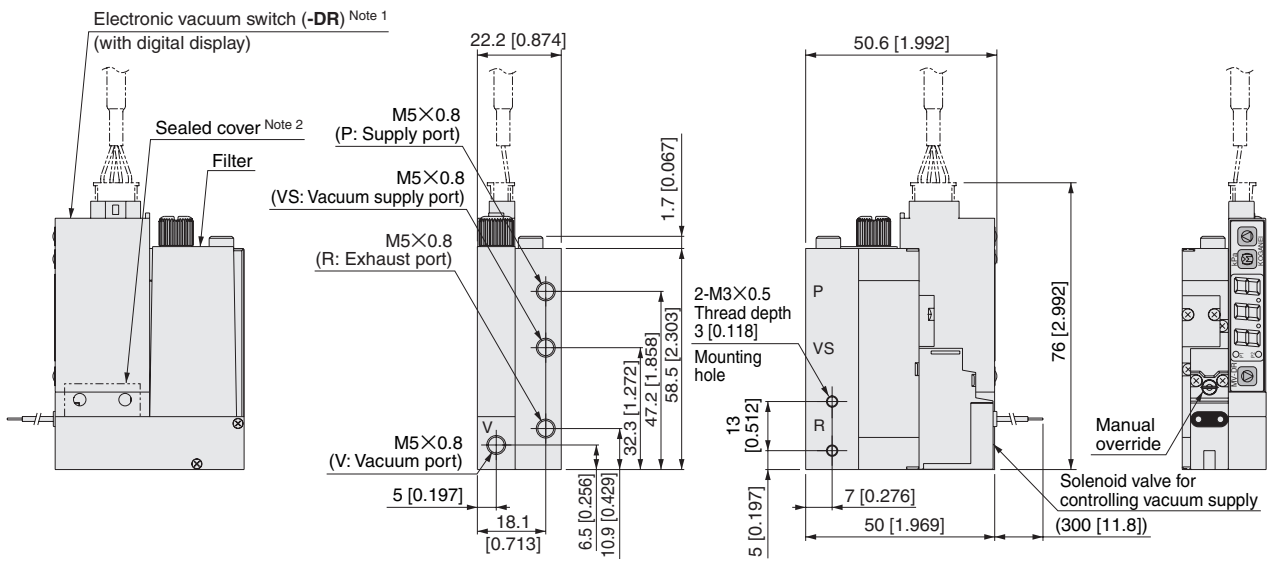

Notes: 1. The electronic vacuum switch (-DR) comes with a cable with connector.
2. For cases without electronic vacuum switch

Option

●Pressure sensor (-EA, -ER)

Remark: Cable length available at 3000 mm [118 in.] only.

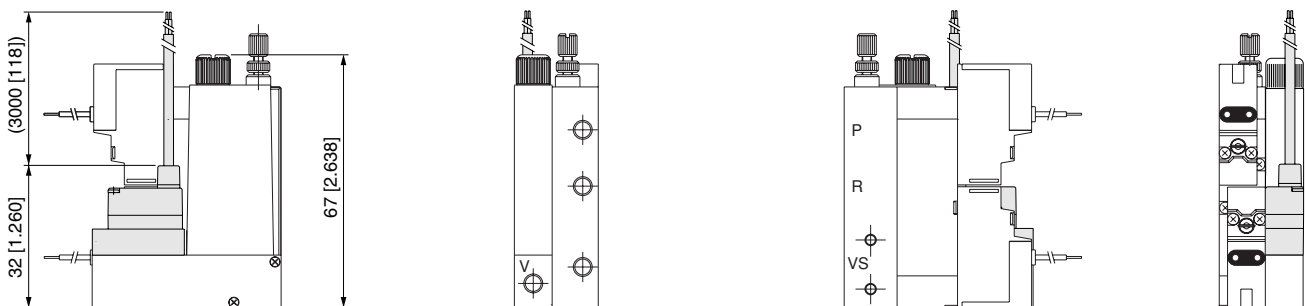

Dimensions mm [in.]

●MV180-01B

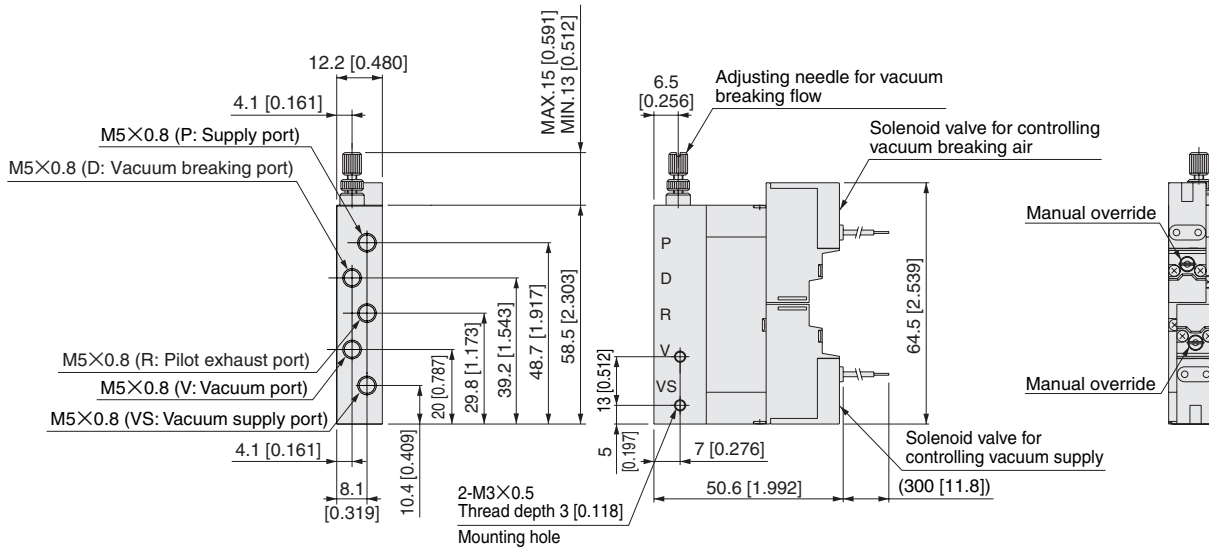

●MV180-02B

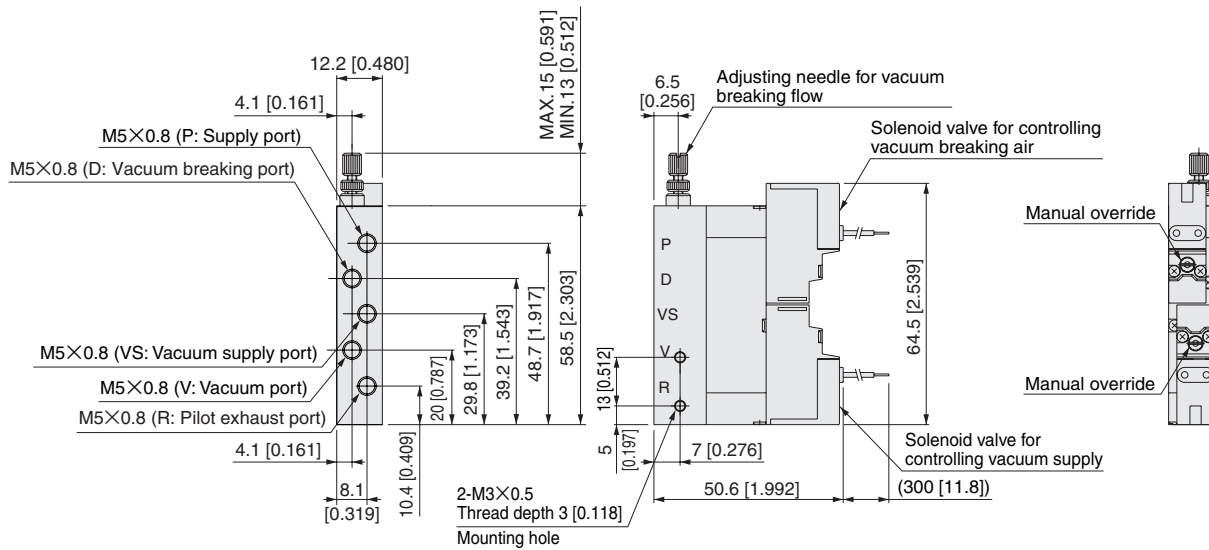

Option

●With wiring specification L connector (-PL, -ML)

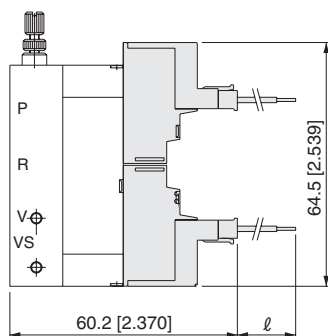

Model	Code	l
Blank		300 [11.8]
-1L		1000 [39.4]
-3L		3000 [118]

●MV180-03B

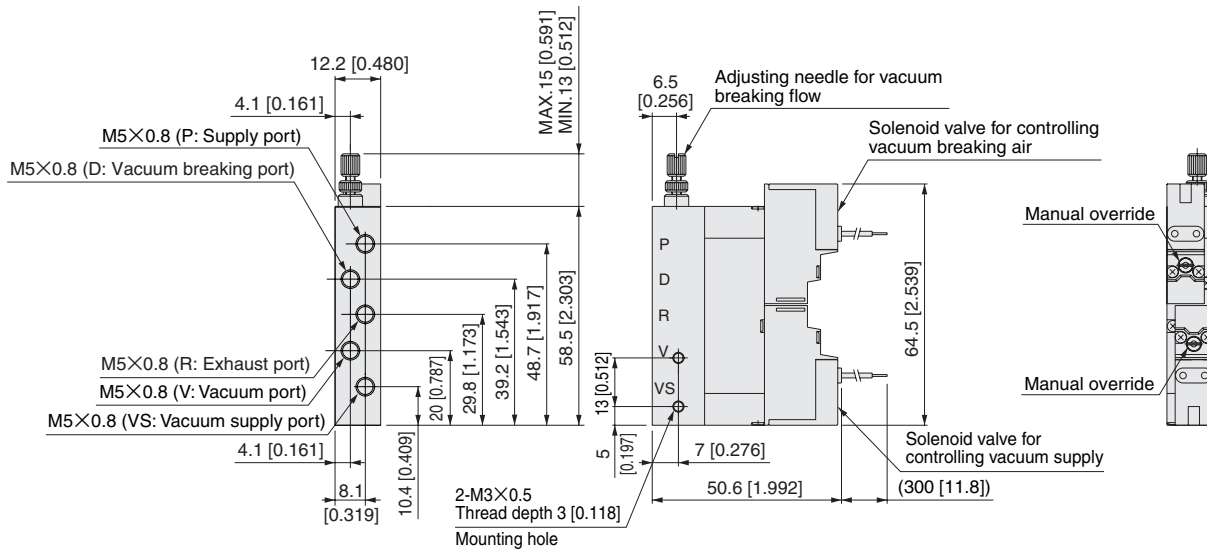

●MV180-04B

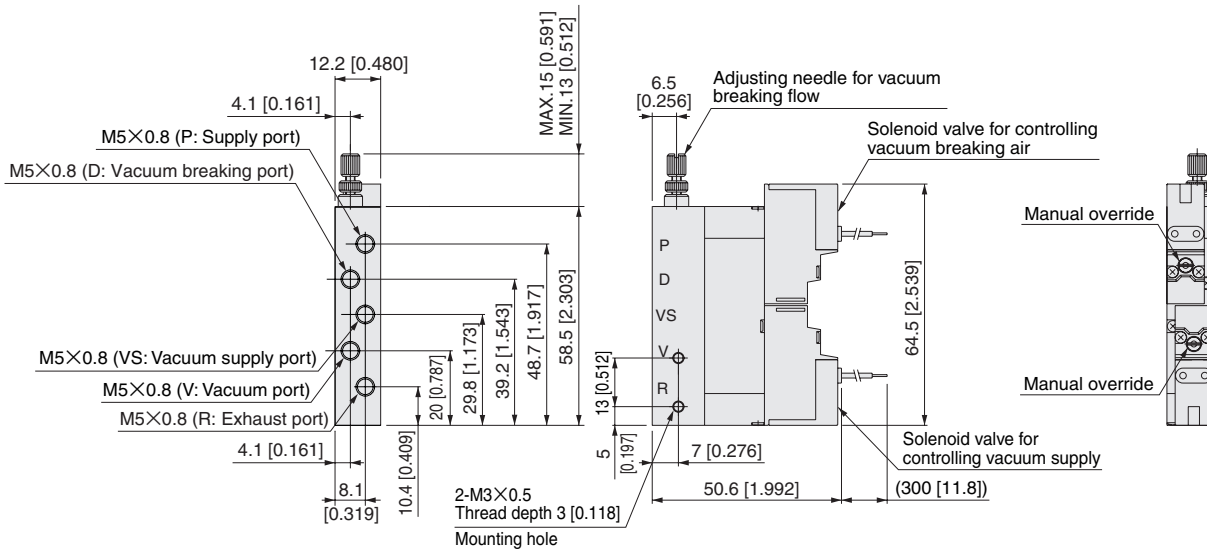

●MV180-01B-DR-F

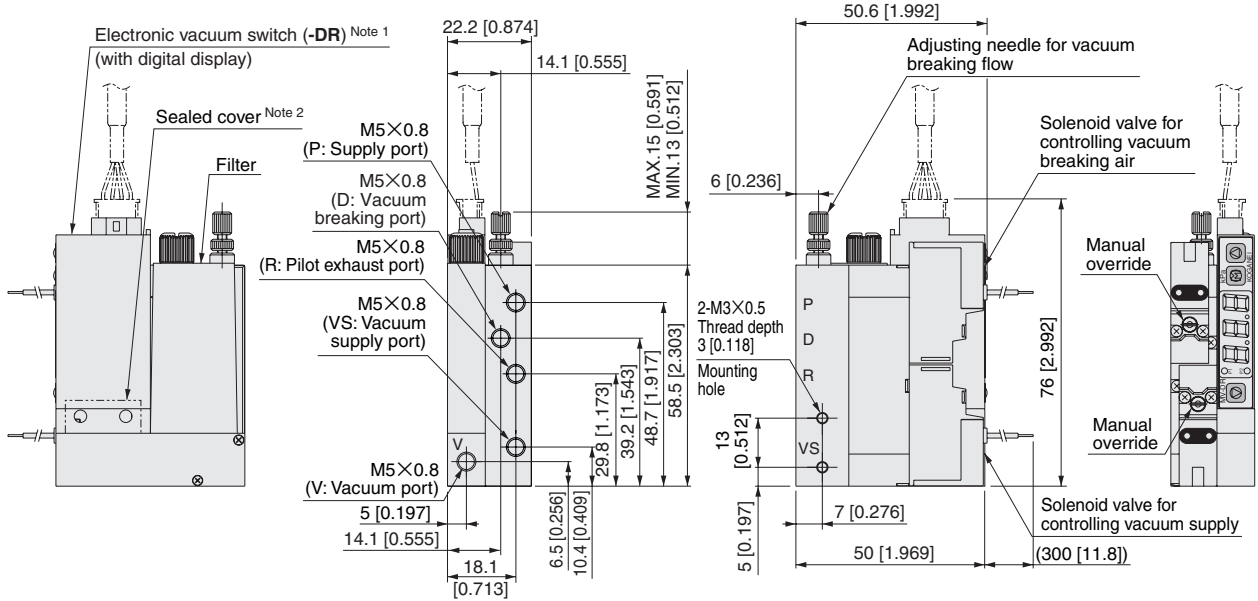

Notes: 1. The electronic vacuum switch (-DR) comes with a cable with connector.
 2. For cases without electronic vacuum switch

●MV180-02B-DR-F

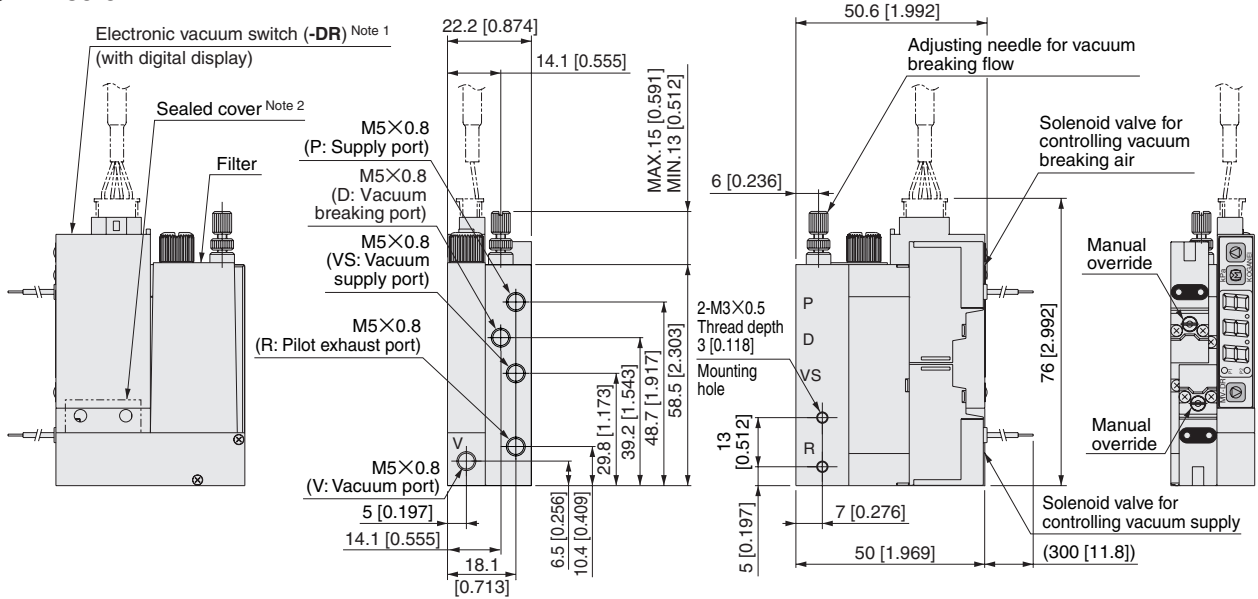

Notes: 1. The electronic vacuum switch (-DR) comes with a cable with connector.
 2. For cases without electronic vacuum switch

Option

●With L connector wiring specification (-PL, -ML)

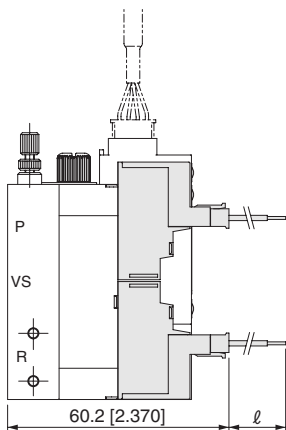

Model	Code	l
Blank	300	[11.8]
-1L	1000	[39.4]
-3L	3000	[118]

●Cable length of electronic vacuum switch (-DR)

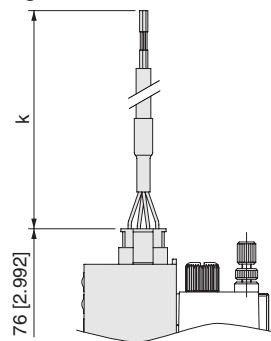

Model (wiring specifications and lead wire length)	Code	k
-PL-Blank, -PL-1L -ML-Blank, -ML-1L		1500 [59]
-PL-3L, -ML-3L		3000 [118]

Dimensions mm [in.]

●MV180-03B-DR-F

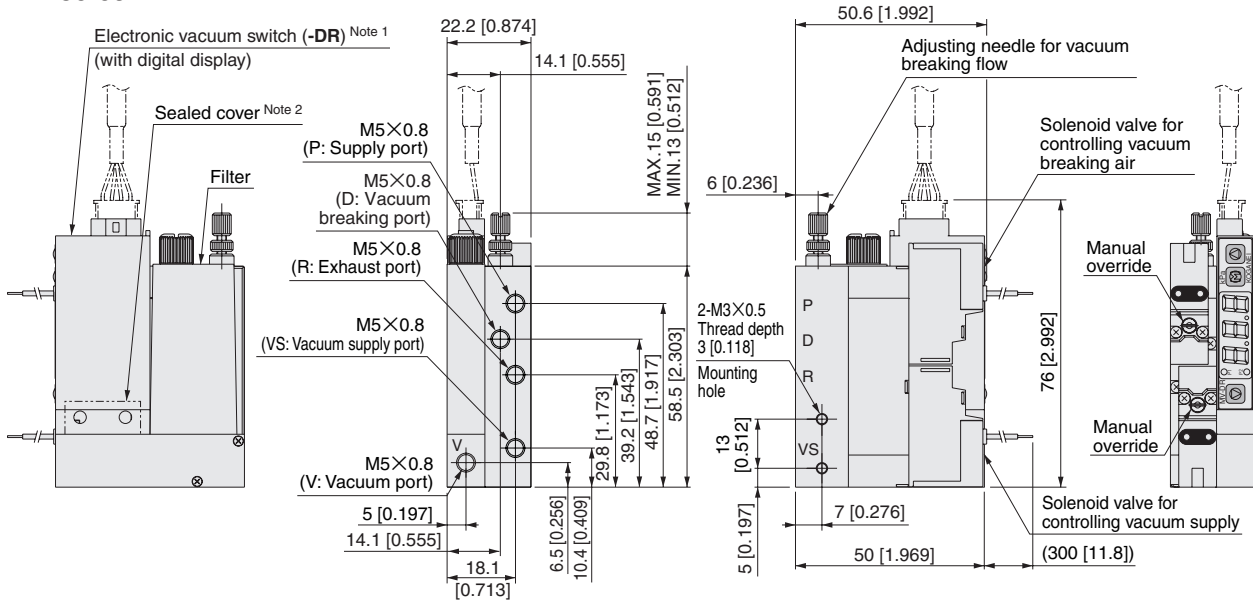

Notes: 1. The electronic vacuum switch (-DR) comes with a cable with connector.
2. For cases without electronic vacuum switch

●MV180-04B-DR-F

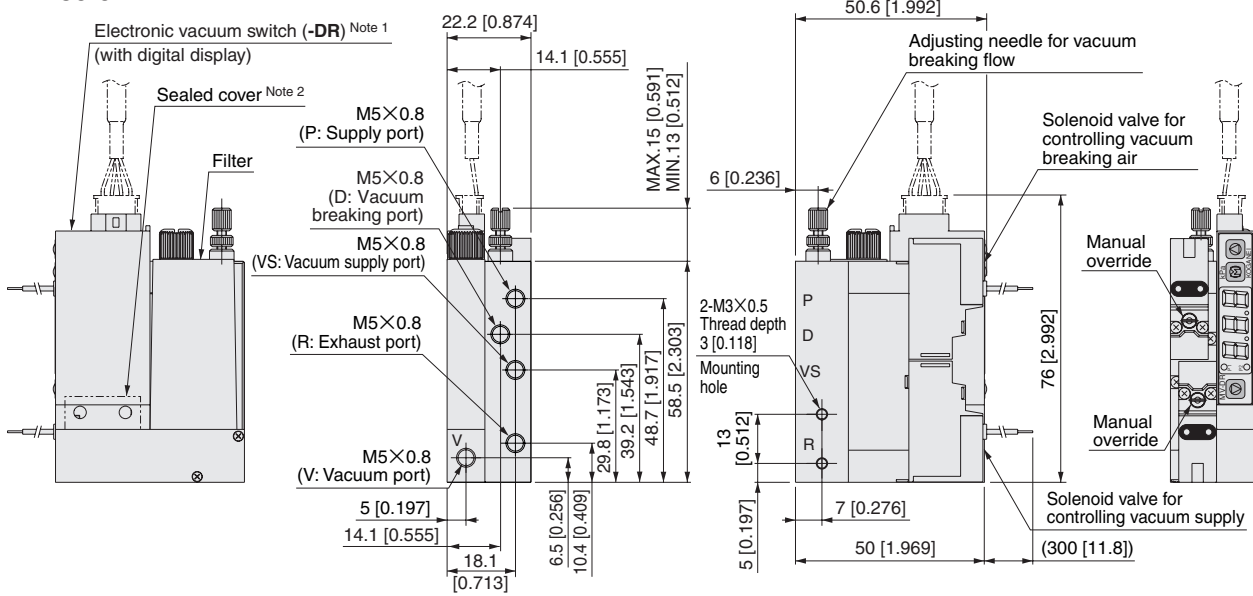

Notes: 1. The electronic vacuum switch (-DR) comes with a cable with connector.
2. For cases without electronic vacuum switch

Option

●With electronic vacuum switch (-DA)

Remark: Cable length available at 1500 mm [59 in.] only.

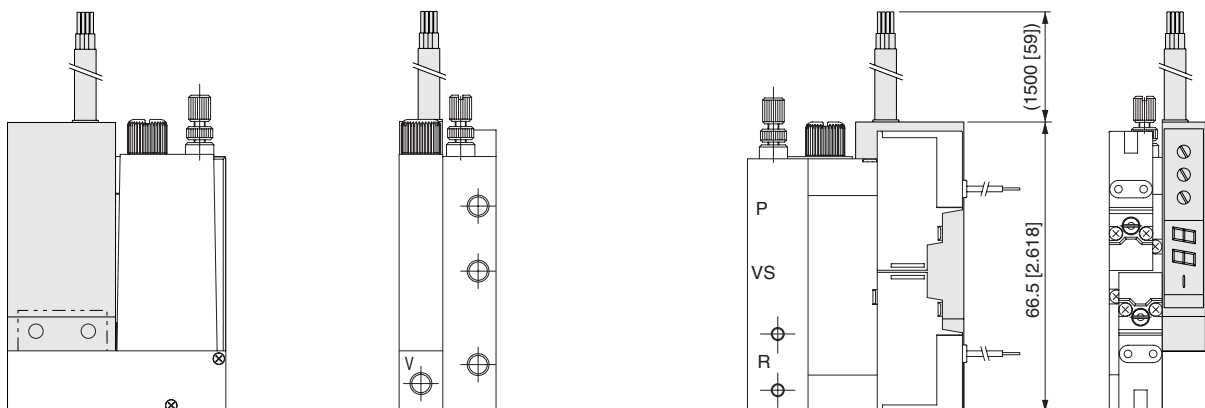

Dimensions mm [in.]

Option

- Pressure sensor (-EA, -ER)

Remark: Cable length available at 3000 mm [118 in.] only.

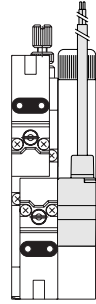
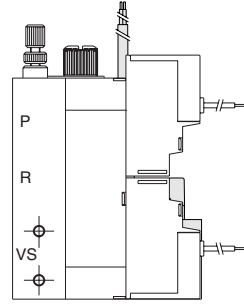
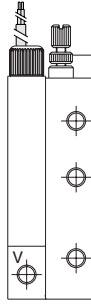
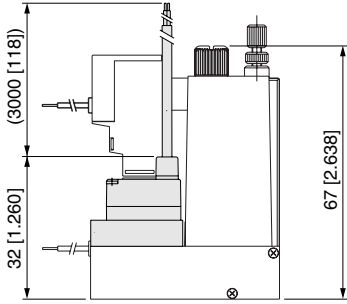

A type manifold

●MV180M8A

- stn.1 AMV180-01
- stn.2 AMV180-03-F
- stn.3 AMV180-03-EA-F
- stn.4 AMV180-05-ER-F
- stn.5 AMV180-01-DA-F
- stn.6 AMV180-05-DA-F
- stn.7 AMV180-03-DR-F-PL
- stn.8 AMV180-05-DR-F-PL

No. of units	L	P	M
2	25.0 [0.984]	47.0 [1.850]	36.0 [1.417]
3	37.5 [1.476]	59.5 [2.343]	48.5 [1.909]
4	50.0 [1.969]	72.0 [2.835]	61.0 [2.402]
5	62.5 [2.461]	84.5 [3.327]	73.5 [2.894]
6	75.0 [2.953]	97.0 [3.819]	86.0 [3.386]
7	87.5 [3.445]	109.5 [4.311]	98.5 [3.878]
8	100.0 [3.937]	122.0 [4.803]	111.0 [4.370]

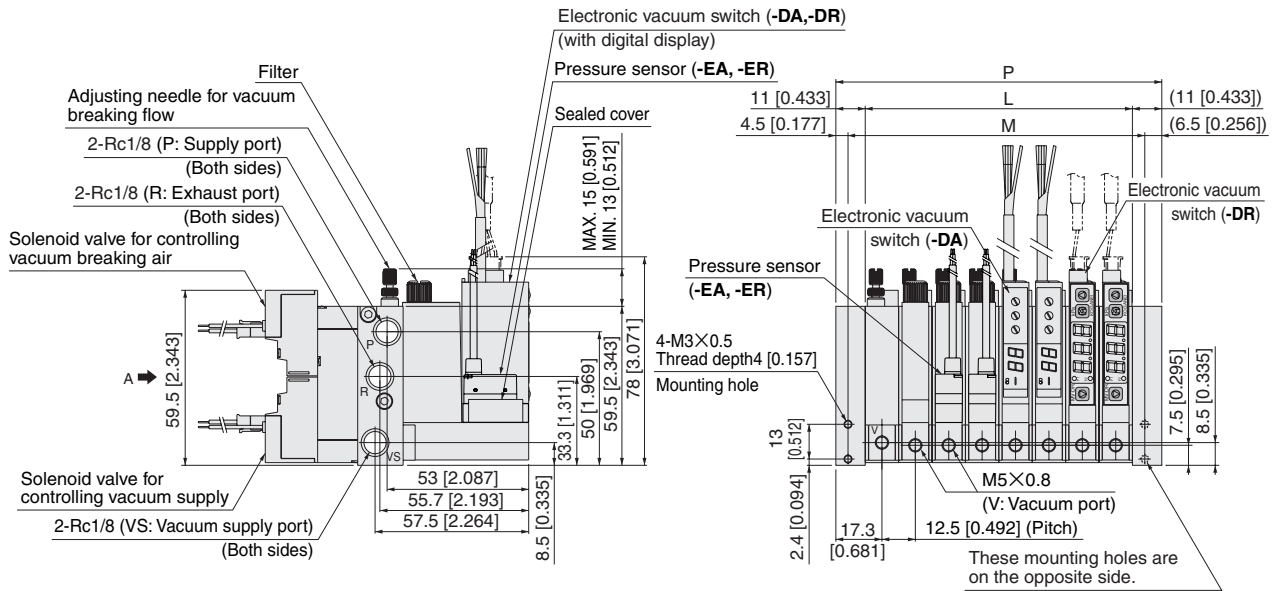
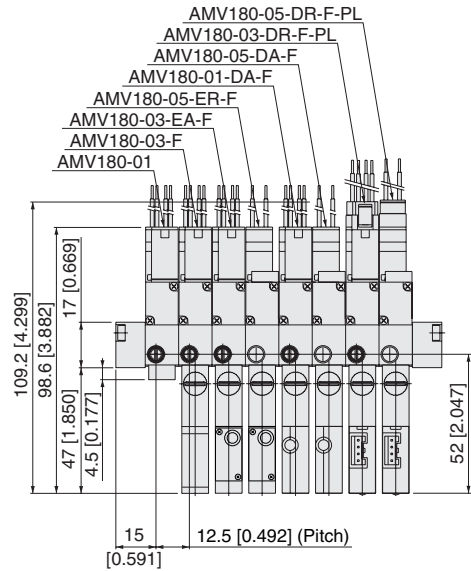
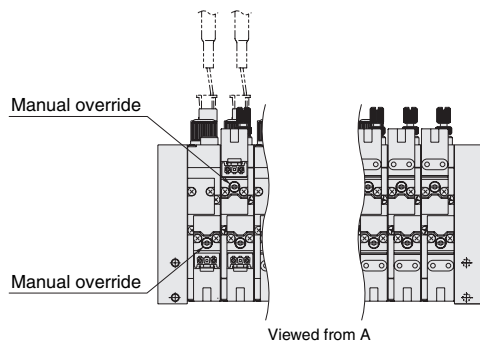

Remark: For the solenoid valve lead wire length, electronic vacuum switch, and pressure sensor cable length, see the single unit dimension diagrams on p.665~667.

A type manifold
●MV180M8A-11

- stn.1 AMV180-02
- stn.2 AMV180-04-F
- stn.3 AMV180-04-EA-F
- stn.4 AMV180-06-ER-F
- stn.5 AMV180-02-DA-F
- stn.6 AMV180-06-DA-F
- stn.7 AMV180-04-DR-F-PL
- stn.8 AMV180-06-DR-F-PL

No. of units	L	P	M
2	25.0 [0.984]	47.0 [1.850]	36.0 [1.417]
3	37.5 [1.476]	59.5 [2.343]	48.5 [1.909]
4	50.0 [1.969]	72.0 [2.835]	61.0 [2.402]
5	62.5 [2.461]	84.5 [3.327]	73.5 [2.894]
6	75.0 [2.953]	97.0 [3.819]	86.0 [3.386]
7	87.5 [3.445]	109.5 [4.311]	98.5 [3.878]
8	100.0 [3.937]	122.0 [4.803]	111.0 [4.370]

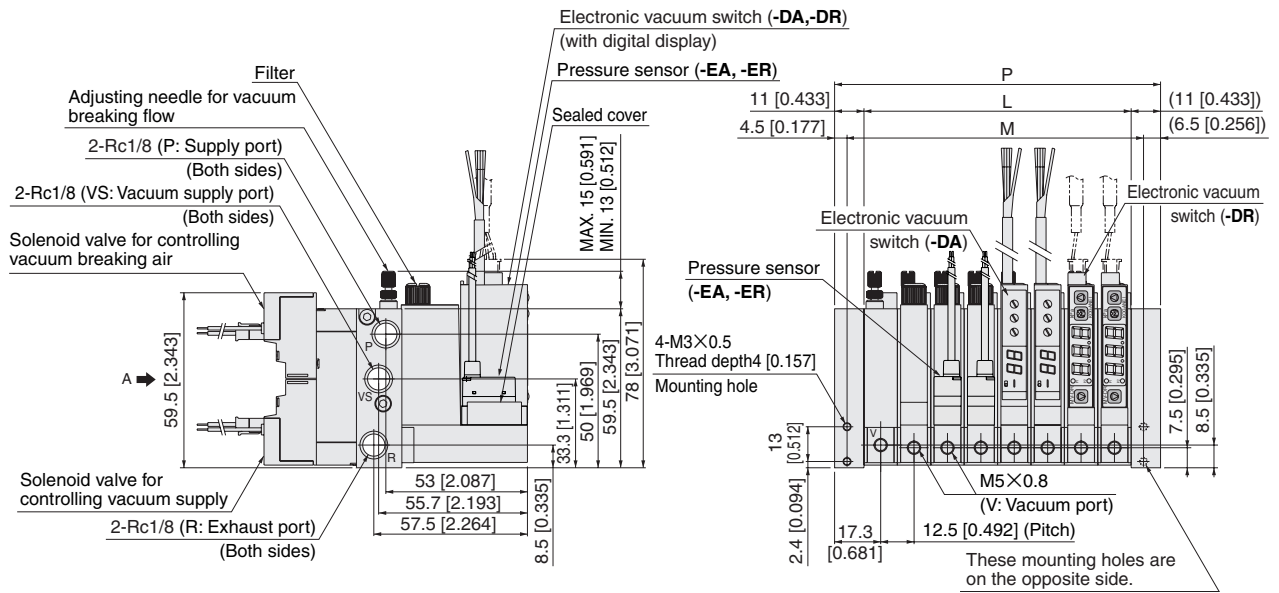
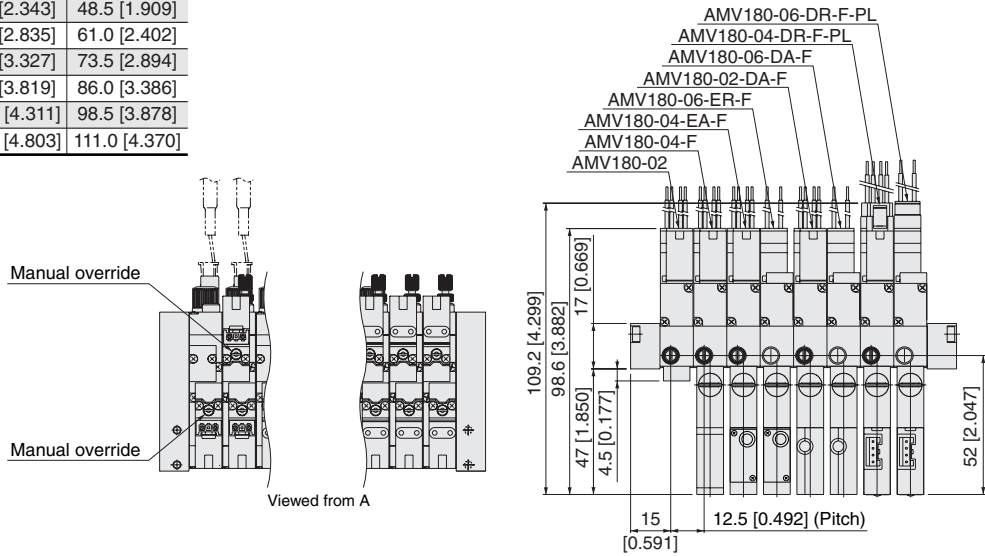

Remark: For the solenoid valve lead wire length, electronic vacuum switch, and pressure sensor cable length, see the single unit dimension diagrams on p.665~667.

● Mounting base MV-21

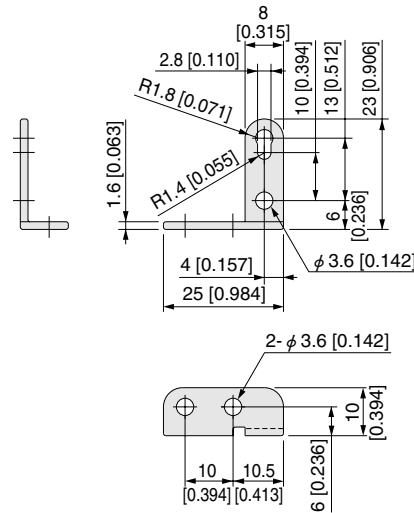

MV180-□

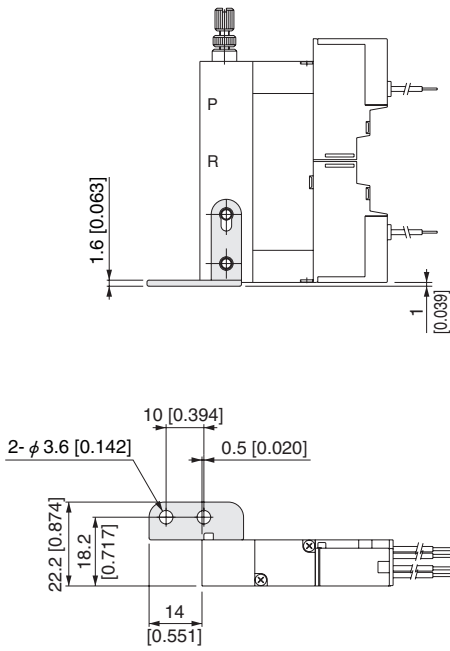

MV180-□-□-F

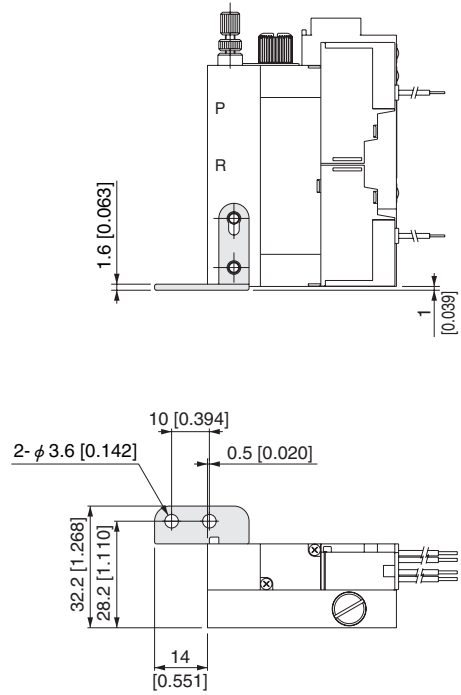

Dimensions mm [in.]

MV180M A
 MV180M A-11

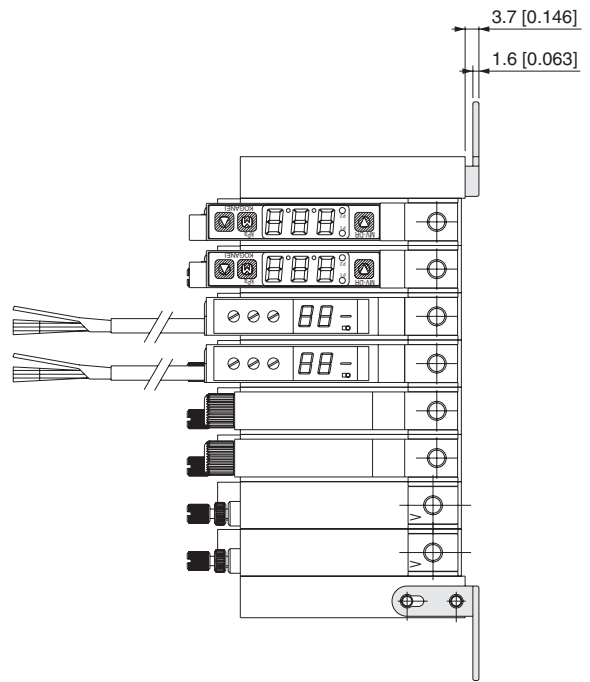
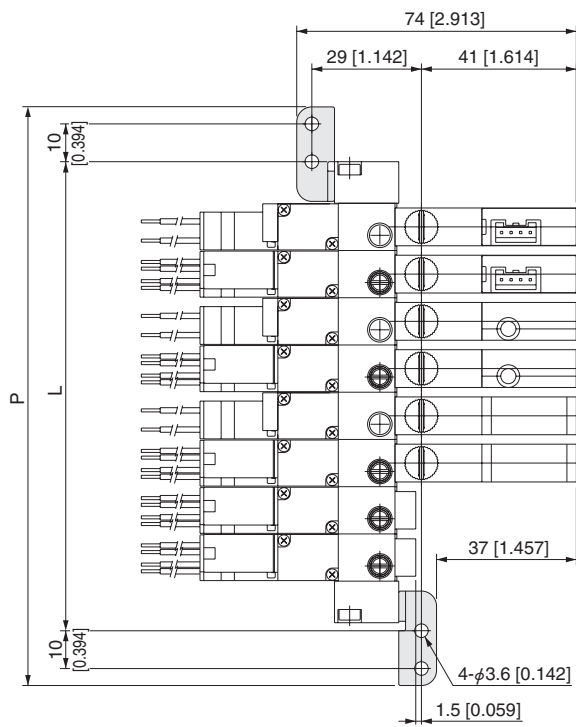

No. of units	L	P
2	49.0 [1.929]	78.0 [3.071]
3	61.5 [2.421]	90.5 [3.563]
4	74.0 [2.913]	103.0 [4.055]
5	86.5 [3.406]	115.5 [4.547]
6	99.0 [3.898]	128.0 [5.039]
7	111.5 [4.390]	140.5 [5.531]
8	124.0 [4.882]	153.0 [6.024]

Note: When using a mounting base for the manifold installation, use M3 screws to attach.

Recommended Fittings

The quick fittings shown below are the optimum fitting type for piping to the vacuum valve unit

● Single unit

Port \ Model	MV030		MV090, MV180	
	(-01, -02, -03, -04)	(-01, -02, -03, -04, -05, -06) -□-F	(-01, -02, -03, -04)	(-01, -02, -03, -04, -05, -06) -□-F
P port	TSH6-M5M	TSH6-M5M	TSH6-M5M	TSH6-M5M
R port	TS4-M5M, KM-05	TS4-M5M, KM-05	TSH6-M5M, KM-05	TSH6-M5M, KM-05
VS port	TSH6-M5M	TSH6-M5M	TSH6-M5M	TSH6-M5M
V port	TSH6-M5M	TSH6-M5M	TSH6-M5M	TSH6-M5M

● Manifold

Port \ Model	MV030MA	MV030MA-11	MV090MA (-11), MV180MA (-11)	MV030MAS	MV030MAS-11	MV090MAS (-11)
P port	TSH6-M5M	TSH6-M5M	TSH6-M5M	TSH6-M5M	TSH6-M5M	TSH6-M5M
R port	TSH4-M5M, KM-05	TS4-M5M, KM-05	TSH6-M5M, KM-05	TSH4-M5M, KM-05	TS4-M5M, KM-05	TSH6-M5M, KM-05
VS port	TS8-01	TS8-01	TS8-01	TS8-01	TS8-01	TS8-01
V port	TSH6-M5M	TSH6-M5M	TSH6-M5M	TSH6-M5M	TSH6-M5M	TSH6-M5M