

SLIT TYPE RODLESS CYLINDERS ORW series

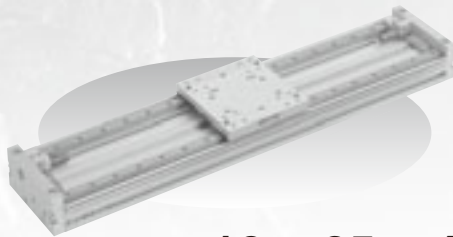

- Equivalent bore size: $\phi 16$, $\phi 25$, $\phi 40$
[0.630in.] [0.984in.] [1.575in.]

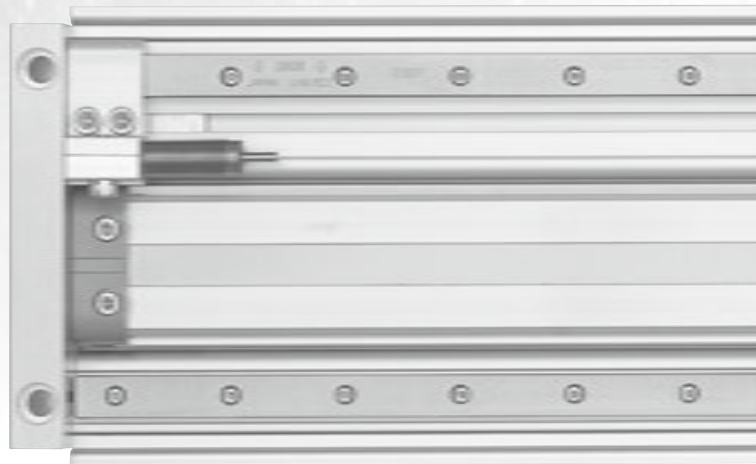

MAGNET TYPE RODLESS CYLINDERS MRW series

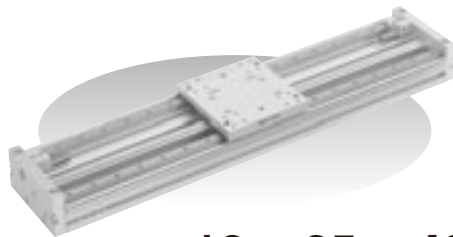

- Bore size: $\phi 16$, $\phi 25$, $\phi 40$
[0.630in.] [0.984in.] [1.575in.]



High rigidity...

- Pitching moment: **185 N·m** [136ft·lbf] (ORW40, MRW40)
- Rolling moment: **200 N·m** [148ft·lbf] (ORW40, MRW40)
- Yawing moment: **185 N·m** [136ft·lbf] (ORW40, MRW40)

Remark: Rodless cylinders **ORS** and **MRS** series:

- Pitching moment: 60N·m [44ft·lbf] (**ORS40, MRS40**)
- Rolling moment: 50N·m [37ft·lbf] (**ORS40, MRS40**)
- Yawing moment: 60N·m [44ft·lbf] (**ORS40, MRS40**)

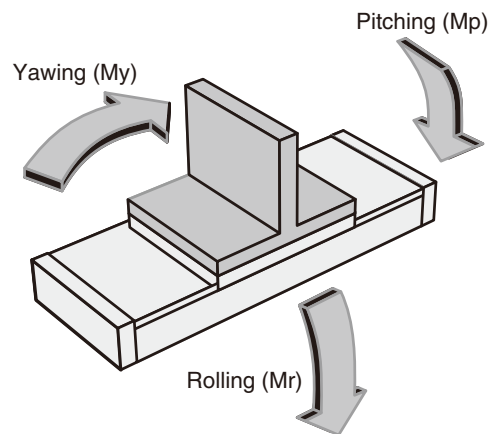

Specified stroke +10mm [0.394in.]

Since the shock absorber can be used for fine stroke adjustment of +5mm [0.197in.] for one side, it totally offers a +10mm [0.394in.] margin in regards to the specified stroke.

Piping concentrated on one side

Concentrated connection ports as standard equipment save space.

Shock absorber units are standard equipment.



Since shock absorber unit provides positioning of the end of the stroke, it enhances absorbing capacity to the maximum extent. The shock absorber does not protrude beyond the end plate. Moreover, moving the shock absorber unit is all that is required to adjust the stroke all along its range.

Uses embedded type sensor switch



Easily and clearly pulling out lead wires from the grooves on the body.

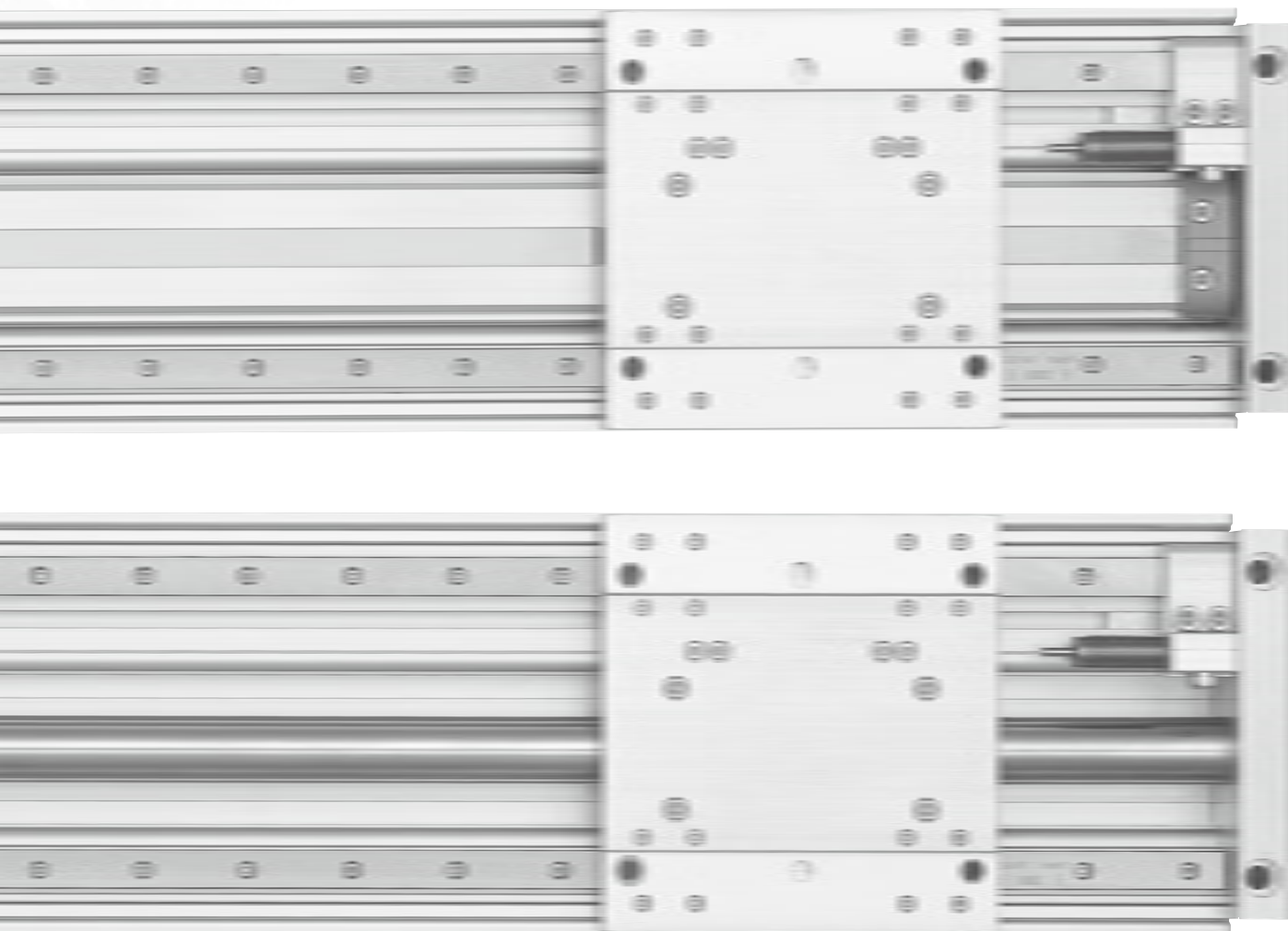

Note: Heli-serts and dowel pin holes are optional.

Maximum load capacity: **600N** [135lb.] (ORW40, MRW40)

Used guide

Model	Guide model ^{Note}	Guide manufacture ^{Note}
ORW16, MRW16	LWL12	IKO Nippon Thompson Co., Ltd.
ORW25, MRW25	LWL15	
ORW40, MRW40	LWES15	

Note: The guide specifications may be changed without notice.

Versatile mounting direction



More versatile mounting, with direct mounting at the end plate, or mounting with T-slots on the bottom surface.

Threads with heli-serts and dowel pin holes on the table are optional.

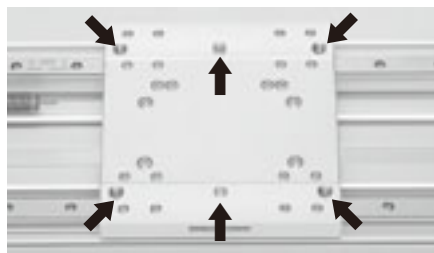

Handling Instructions and Precautions



General precautions

Piping

1. Always thoroughly blow off (use compressed air) the tubing before connecting it to the rodless cylinder. Entering chips, sealing tape, rust, etc., generated during piping work could result in air leaks or other defective operation.
2. When screwing piping or fittings to rodless cylinders, tighten them using the following tightening torques.

Connecting thread	Tightening torque N·m [ft·lbf]
M5×0.8	1.57 [1.16]
Rc1/8	6.77~8.63 [4.99~6.37]
Rc1/4	11.57~13.44 [8.53~9.91]

Atmosphere

1. If using in locations subject to dripping water, dripping oil, etc., or to large amounts of dust, use a cover to protect the unit or mount with the slider facing downward.
2. Do not engage in electric welding close to the rodless cylinders **ORW**, **MRW** series. The welding spatters could damage the outer seal band, etc.
3. The product cannot be used when the media or ambient atmosphere contains any of the substances listed below.
Organic solvents, phosphate ester type hydraulic oil, sulphur dioxide, chlorine gas, or acids, etc.

Lubrication

1. The product can be used without lubrication, if lubrication is required, use Turbine Oil Class 1 (ISO VG32) or equivalent.
2. Apply lithium soap-based grease No.2 or equivalent on the raceway surface in the guide every 6 months or every 300km [186mi.] of traveling distance.

Media

1. Use air for the media. For the use of any other media, consult us.
2. Air used for the rodless cylinders **ORW**, **MRW** series should be clean air that contains no moisture, dust, and oxidized compressor oil, etc. Install an air filter (filtration of a minimum 40 µm) near the rodless cylinders **ORW**, **MRW** series or valve to remove collected liquid or dust. In addition, drain the air filter periodically.



Selection and Mounting

Allowable load and moment

Although the rodless cylinders **ORW**, **MRW** series can be used with directly applying loads, make sure that the load and moment do not exceed the values in the table below.

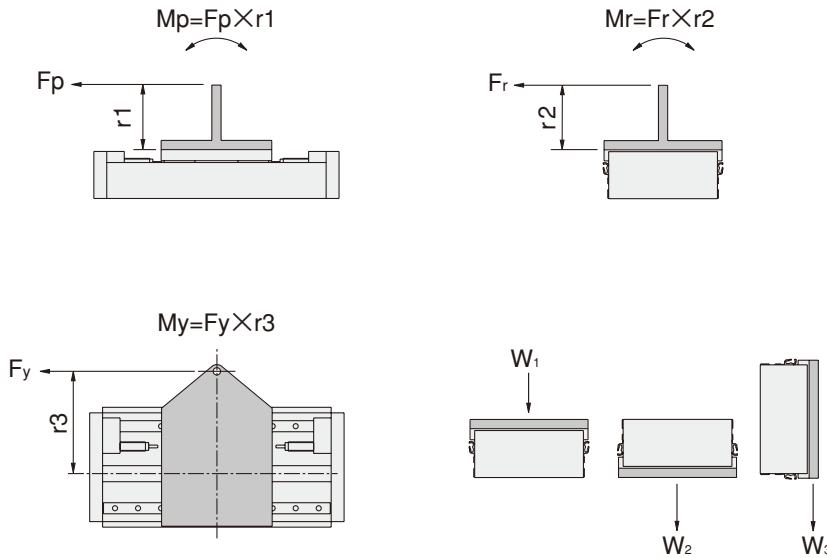

Pitching moment : $M_p = F_p \times r_1$ (N·m)

Rolling moment : $M_r = F_r \times r_2$ (N·m)

Yawing moment : $M_y = F_y \times r_3$ (N·m)

Maximum load capacity : W_1, W_2, W_3 (N)

Model	Moment and Max. load	M_p	M_r	M_y	W_1	W_2	W_3
		N·m [ft·lbf]	N·m [ft·lbf]	N·m [ft·lbf]	N [lbf.]	N [lbf.]	N [lbf.]
ORW16, MRW16		45 [33]	50 [37]	45 [33]		130 [29]	
ORW25, MRW25		95 [70]	105 [77]	95 [70]		300 [67]	
ORW40, MRW40		185 [136]	200 [148]	185 [136]		600 [135]	

Caution: The moment including the inertial force generated when the load is moved or stopped must not exceed the values in the above table.
For the load and speed, keep within the range of the shock absorber capacity graph.

Area moment of inertia of the base

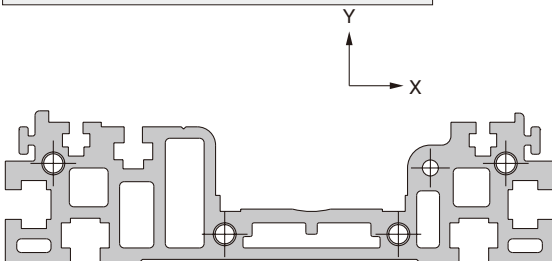

The above diagram shows base cross section of **ORW16, MRW16**.

●ORW16, MRW16

Cross section characteristics	
A	1520.82mm ² [2.357in. ²]
I _x	1.310×10 ⁵ mm ⁴ [3.147×10 ⁻¹ in. ⁴]
I _y	2.283×10 ⁶ mm ⁴ [5.485in. ⁴]
Z _x	6.753×10 ³ mm ³ [4.121×10 ⁻¹ in. ³]
Z _y	3.783×10 ⁴ mm ³ [2.309in. ³]

●ORW25, MRW25

Cross section characteristics	
A	2396.05mm ² [3.714in. ²]
I _x	3.752×10 ⁵ mm ⁴ [9.014×10 ⁻¹ in. ⁴]
I _y	6.038×10 ⁶ mm ⁴ [1.451×10in. ⁴]
Z _x	1.480×10 ⁴ mm ³ [9.031×10 ⁻¹ in. ³]
Z _y	7.970×10 ⁴ mm ³ [4.864in. ³]

●ORW40, MRW40

Cross section characteristics	
A	3951.90mm ² [6.125in. ²]
I _x	1.143×10 ⁶ mm ⁴ [2.746in. ⁴]
I _y	1.714×10 ⁷ mm ⁴ [4.118×10in. ⁴]
Z _x	3.359×10 ⁴ mm ³ [2.050in. ³]
Z _y	1.732×10 ⁵ mm ³ [1.057×10in. ³]

Handling Instructions and Precautions

Shock absorber absorption capacity

Shock absorbers are standard equipment for the entire rodless cylinders **ORW**, **MRW** series. Find the figures for the absorption mass and impact speed from the impact speed graph, which then should be within the ranges of the "Shock absorber capacity graph" below. It cannot be used with speeds in excess of the maximum operating speeds of 1000mm/s [39.4in./sec.] or 2000mm/s [78.7in./sec.].

Impact speed graph (Horizontal use, at air pressure of 0.5MPa)

The graph below shows the table's required time to reach the end of the stroke, at impact speeds of 1000mm/s [39.4in./sec.] or 2000mm/s [78.7in./sec.], for each stroke.

In operation, set the time in above area of the graph's curve.

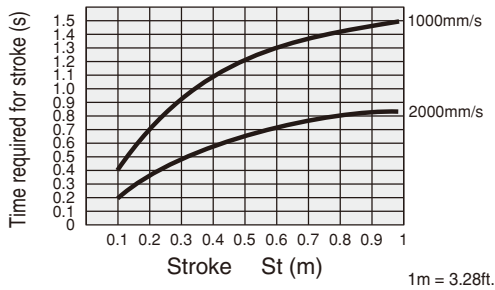

Shock absorber capacity graph

(Horizontal operation, at air pressure of 0.5MPa)

The "mass" in the graph refers to the total mass carried by the **ORW** and **MRW** series. "Impact speed" refers to the speed immediately before striking the shock absorber. Note that this is not the same as "average speed (cylinder stroke/time required)."

For ORW16 and MRW16

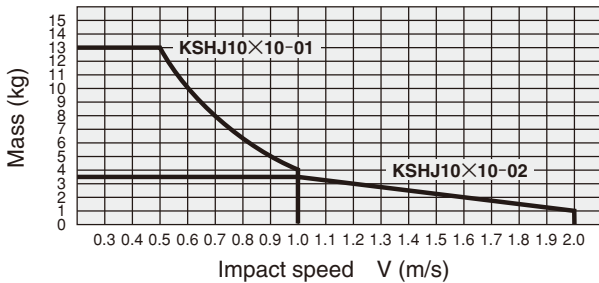

For ORW25, MRW25

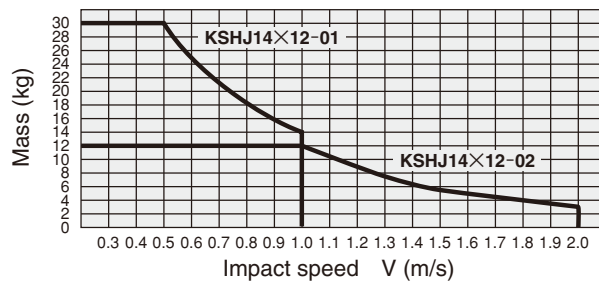

For ORW40, MRW40

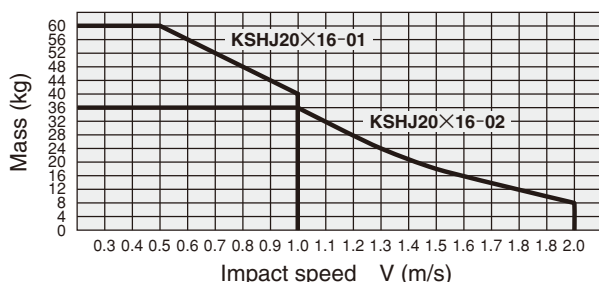

1kg = 2.205lb. 1m/s = 3.28ft./sec.

Shock absorber stroke adjustment

In the rodless cylinders **ORW** and **MRW** series, stroke adjustment by the shock absorber is easy for entire strokes.

- Loosen the holder mounting bolts, and move the attachment holder to determine the rough position.
- Press the holder against the guides such that the shock absorber contacts the impact surface of the table at right angles, and then tighten and secure it in place with the holder mounting bolts.
- Next, loosen the shock absorber mounting bolt.
- Insert a flat blade screwdriver into the shock absorber straight groove to finely adjust the position by rotating it so that it provides the required stopping position of the table.
- Finally, tighten and secure the shock absorber mounting bolt, and complete the operation.

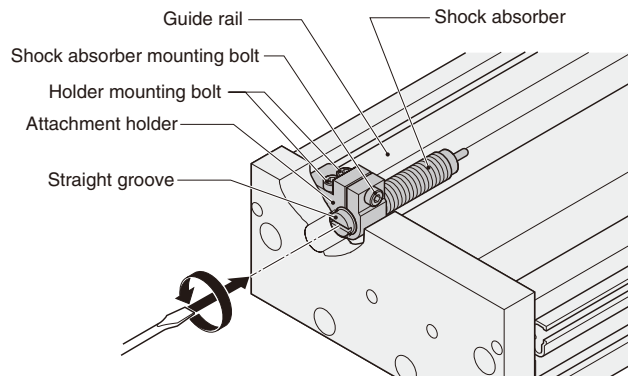

Approximate tightening torque for holder mounting bolt

Model	Tightening torque N·cm [in·lbf]	Allen wrench size mm [in.]
ORW16, MRW16	200 [17.7]	3 [0.118]
ORW25, MRW25	700 [62.0]	5 [0.197]
ORW40, MRW40	1700 [150.5]	6 [0.236]

Remark: For securing the shock absorber holder in place, use the above values to tighten the bolt.

- Cautions:**
- Adjust it so that the stopper on the table and the shock absorber make full contact.
 - Use the shock absorber within the range of the capacity of the shock absorber (range of the capacity graph). Note that the absorption energy of the shock absorber is different in a low-speed range than that in a high-speed range.
 - The maximum impact speed of the shock absorber will vary depending on the shock absorber. Moreover, since impact speed and average speed are not the same, use only after checking the shock absorber's impact speed.
 - Do not use the shock absorber in a place subject to dripping water or oil, or to large amount of dust. If using it in these places, install a cover, etc. so that the water or oil drops do not drip it directly. Otherwise, it could lead to improper operation and may decrease the absorption energy.
 - Do not loosen the small screw on the rear end of the shock absorber. The oil inside will leak out which will fail the function of the shock absorber.
 - To ensure that the table is not in contact with the attachment holder, always adjust the location of the shock absorber so that a clearance exists between the table and the attachment holder. Contact of anything other than the absorber when stopping could result in damage to the cylinder.
 - Do not install other shock absorbers for this product without our permission. Since our shock absorber's characteristics are different from those of other shock absorbers, use of other shock absorbers could cause damage to the cylinder.
 - When using rodless cylinders, select a suitable cushion and shock absorber so as to prevent rebound. In **ORW**, in particular, rebound could cause the seal band to break, etc.

Body mounting

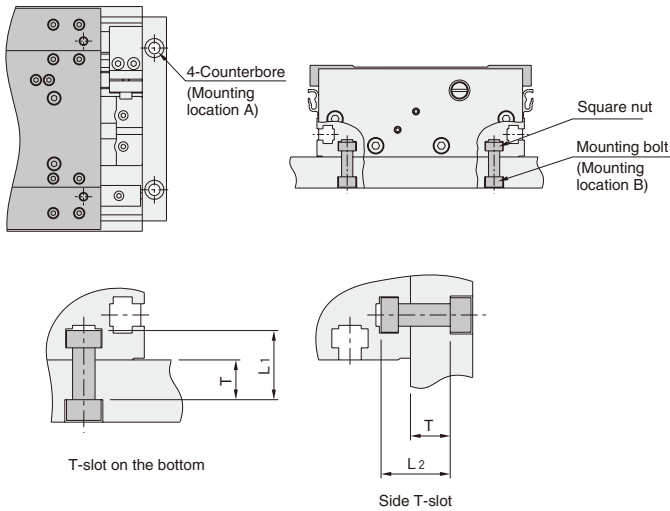

Intermediate stopping control

1. Since for structural reasons external air leakage is inevitable for the **ORW** series, use of all port block (closed center) 3-position valves, etc., for intermediate stop control could result in failure to maintain the stopping position, and the piston speed could not be controlled when restarting. We recommend, therefore, the installation of double-sided pressure control circuits that use PAB-connection (pressure center) 3-position valves, etc.
For intermediate stopping under constant loads, such as vertical mountings, consult us.
2. For the **MRW** series, hold the pressure at 0.55MPa [80psi.] or less when used with external stoppers, etc., for intermediate stroke stopping. Use at higher pressures may cause the piston to misalign.

● Tightening torque

N·m [ft·lbf]

Model	ORW16, MRW16	ORW, MRW25	ORW40, MRW40
Mounting location A	10.0 [7.4] (M6)	20.0 [14.8] (M8)	40.0 [29.5] (M10)
Mounting location B	4.5 [3.3] (M6)	13.5 [10.0] (M8)	24.0 [17.7] (M10)

● Screw length

mm [in.]

Code	Model	ORW16, MRW16	ORW25, MRW25	ORW40, MRW40
L ₁		T + 8.5 [0.335] (M6)	T + 10.5 [0.413] (M8)	T + 14 [0.551] (M10)
L ₂				T + 13 [0.512] (M10)

1. Because the cylinder mounting frame is subject to large reaction forces during rodless cylinder's operation, use a frame with high rigidity. Insufficient rigidity can result in vibrations (resonance) that can have an adverse effect on rodless cylinder operations.
2. For the rodless cylinder mounting surface, ensure a flatness and horizontal accuracy of $\pm 0.1/500\text{mm}$ [$\pm 0.004/19.69\text{in.}$] or better. Insufficient accuracy in the mounting surface may degrade rodless cylinder's operability, resulting in sticking or operating failure.
3. While any mounting direction in the rodless cylinders **ORW**, **MRW** series is allowed, mount the slider so that it faces downward or protect it with a cover, etc., when mounting in locations subject to dripping water or oil, etc., or to large amounts of dust. Mounting as the seal band faces downward is particularly effective for the **ORW** series.
4. Avoid any electric welding either during or after mounting the rodless cylinders **ORW**, **MRW** series. Flows of welding current to the cylinder could generate arcs that result in damage or depositions to the cylinder.
5. Since the magnet type rodless cylinders **MRW** series has strong magnets built into the cylinder body, do not use in locations subject to cutting oil or metal chips that contain magnetized materials.
6. Be careful to avoid making scratches or dents, etc., on the cylinder tube/barrel and guide.
7. If external forces exceeding the magnet retaining force cause the slider and piston to become misaligned or separated, make the piston return to the end of the stroke and then apply an external force to the slider to restore it to the correct position.
8. If using in locations where the cylinder tube/barrel and guide can easily become smeared, clean the cylinder tube/barrel and guide periodically.
After cleaning, always apply lubrication to the cylinder tube and guide surfaces.
9. Avoid using the rodless cylinders **ORW**, **MRW** series in combination with linear ball bearings and other external guides.

Caution: Do not apply a strong shock to the slit portion of the cylinder barrel.

Handling Instructions and Precautions

Calculation of impact energy

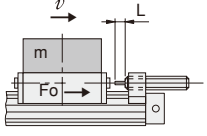
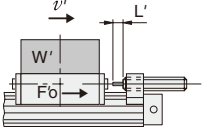
Horizontal impact	
	
$E = E_1 + E_2$ $= \frac{m \cdot v^2}{2} + F_o \cdot L$	$E' = E'_1 + E'_2$ $= \frac{W' \cdot v'^2}{2g'} + F'_o \cdot L'$

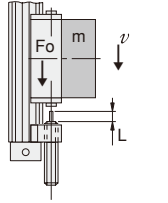
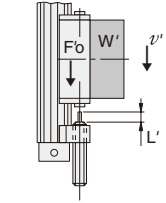
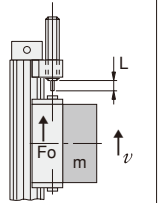
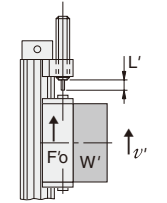
Vertical impact ^{Note 1}			
When descending ^{Note 2}		When ascending	
			
$E = E_1 + E_2 + E_3$ $= \frac{m \cdot v^2}{2} + F_o \cdot L + m \cdot g \cdot L$	$E' = E'_1 + E'_2 + E'_3$ $= \frac{W' \cdot v'^2}{2g'} + F'_o \cdot L' + W' \cdot L'$	$E = E_1 + E_2 - E_3$ $= \frac{m \cdot v^2}{2} + F_o \cdot L - m \cdot g \cdot L$	$E' = E'_1 + E'_2 - E'_3$ $= \frac{W' \cdot v'^2}{2g'} + F'_o \cdot L' - W' \cdot L'$

Note 1: For impact on incline, E_3 becomes $E'_3 = m \cdot g \cdot L \cdot \sin \theta$.

Note 1: For impact on incline, E'_3 becomes $E''_3 = W' \cdot L' \cdot \sin \theta$.

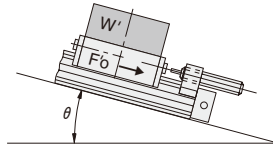
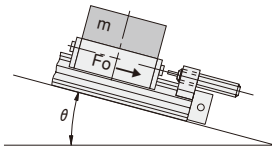

Note 2: When descending, the operating air pressure: P, should be lower than when ascending, because heavier loads can be carried.

E : Total impact energy ... [J]

E_1 : Kinetic energy ... $\frac{m \cdot v^2}{2}$ [J]

E_2 : Additional energy by cylinder thrust ... $F_o \cdot L$ [J]

E_3 : Additional energy by load mass ... $m \cdot g \cdot L$ [J]

m : Load mass [kg]

v : Impact speed [m/s]

g : Gravity acceleration 9.8 [m/s²]

F_o : Cylinder thrust ... $= \frac{\pi}{4} \cdot D^2 \cdot P$ [N]

[D: Cylinder bore (mm) P: Operating air pressure (MPa)]

L : Absorbing stroke of shock absorber [m]

Note 2: When descending, the operating air pressure: P', should be lower than when ascending, because heavier loads can be carried.

E' : Total impact energy ... [ft·lbf]

E'_1 : Kinetic energy ... $\frac{W' \cdot v'^2}{2g'}$ [ft·lbf]

E'_2 : Additional energy by cylinder thrust ... $F'_o \cdot L'$ [ft·lbf]

E'_3 : Additional energy by load weight ... $W' \cdot L'$ [ft·lbf]

W' : Load weight [lbf]

v' : Impact speed [ft./sec.]

g' : Gravity acceleration 32.2 [ft./sec.]

F'_o : Cylinder thrust ... $= \frac{\pi}{4} \cdot D'^2 \cdot P'$ [lbf]

[D': Cylinder bore [in.] P': Operating air pressure [psi.]

L' : Absorbing stroke of shock absorber [ft.]

Symbol

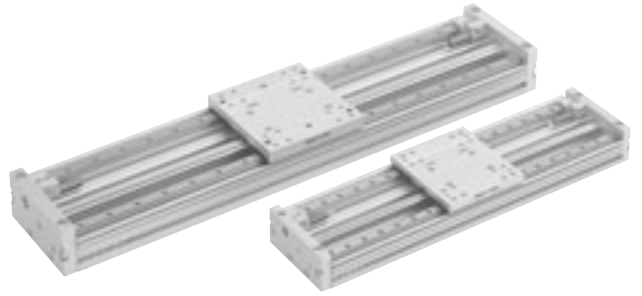
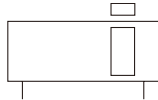

Specifications

Item	Bore size mm [in.]	16 [0.630]		25 [0.984]		40 [1.575]	
		Media	Air ^{Note 1}				
Operation type	Double acting type						
Operating pressure range	MPa [psi.]	0.2~0.7 [29~102]					
Proof pressure	MPa [psi.]	1.05 [152]					
Operating temperature range	°C [°F]	0~60 [32~140]					
Operating speed range	mm/s [in./sec.]	150~1000 [5.9~39.4] (150~2000 [5.9~78.7]) ^{Note 2}		100~1000 [3.9~39.4] (100~2000 [3.9~78.7]) ^{Note 2}			
Cushion	Shock absorber (Standard equipment on both ends)						
Lubrication	Cylinder portion	Not required (If lubrication is required, use Turbine Oil Class 1 [ISO VG32] or equivalent.)					
	Guide portion	Required (Lithium soap-based grease)					
Repeatability	mm [in.]	±0.05 [±0.002]					
Parallelism ^{Note 3}	mm [in.]	0.3 [0.012]					
Stroke	Attachment holder	Adjustable over the entire stroke					
	Shock absorber	Fine adjustment One side -5~+5 [-0.197~+0.197]					
Maximum stroke	mm	1500		2000			
Maximum load capacity ^{Note 4}	N [lbf]	130 [29]		300 [67]		600 [135]	
Port size		M5×0.8		Rc1/8		Rc1/4	

Notes: 1. Use clean air that contains no moisture, dust, oxidized oil or the impurities in the compressed air.

2. Figures in parentheses () are for when MRW series with shock absorbers are set for 2000mm/s [78.7in./sec.] impact speed.

3. This is the parallelism between the upper surface of the table and the bottom of the body. It is not the same as the traveling parallelism.

4. For the relation between the mass and piston speed, see the shock absorber absorption capacity graph on p.1205.

Magnet Retaining Force

Bore size	mm [in.]	16 [0.630]	25 [0.984]	40 [1.575]
Magnet retaining force		156.9 [35.3]	451.1 [101.4]	1147.4 [257.9]

Specifications of Shock Absorber

Item	Model	KSHJ10×10-01		KSHJ10×10-02		KSHJ14×12-01		KSHJ14×12-02		KSHJ20×16-01		KSHJ20×16-02	
		MRW16				MRW25				MRW40			
Maximum absorption	J [ft·lbf]	3 [2.2]		10 [7.4]		30 [22.1]							
Absorbing stroke	mm [in.]	10 [0.394]		12 [0.472]		16 [0.630]							
Maximum impact speed	mm/s [in./sec.]	1000 [39.4]		2000 [78.7]		1000 [39.4]		2000 [78.7]		1000 [39.4]		2000 [78.7]	
Maximum operating frequency	cycle/min	60		40		30							
Maximum absorption per minute	J/min [ft·lbf/min.]	120 [88.5]		240 [177]		450 [332]							
Spring return force ^{Note}	N [lbf.]	8.0 [1.80]		9.2 [2.07]		22.0 [4.95]							
Angle variation		1° or less						3° or less					
Operating temperature range	°C [°F]	0~60 [32~140]											

Note: Values at retracted position.

Caution: The life of the shock absorber may vary from the Magnet Type Rodless Cylinder, depending on its operating conditions.

Cylinder Thrust

N [lbf.]

Bore size mm [in.]	Pressure area mm ² [in. ²]	Air pressure MPa [psi.]					
		0.2 [29]	0.3 [44]	0.4 [58]	0.5 [73]	0.6 [87]	0.7 [102]
16 [0.630]	201 [0.312]	40 [9.0]	60 [13.5]	80 [18.0]	101 [22.7]	121 [27.2]	141 [31.7]
25 [0.984]	490 [0.760]	98 [22.0]	147 [33.0]	196 [44.1]	245 [55.1]	294 [66.1]	343 [77.1]
40 [1.575]	1256 [1.947]	251 [56.4]	377 [84.7]	502 [112.8]	628 [141.2]	754 [169.5]	879 [197.6]

Remark: The above cylinder thrust is the theoretical value. Allow plenty of margin in actual applications.

Bore Size and Stroke

mm

Bore size	Standard strokes	Available strokes
16	100, 200, 300, 400, 500, 600	50~1500
25	200, 300, 400, 500, 600, 700, 800	50~2000
40	300, 400, 500, 600, 700, 800, 1000	50~2000

Remark: Non-standard strokes are available at each 50mm stroke. For delivery, consult us.

Mass

kg [lb.]

Bore size mm [in.]	Zero stroke mass	Additional mass for each 50mm [1.969in.] stroke	Additional mass of 1 sensor switch ^{Note 1}	
			ZE□□□A	ZE□□□B
16 [0.630]	2.49 [5.49]	0.32 [0.71]	0.015 [0.033]	0.035 [0.077]
25 [0.984]	5.30 [11.69]	0.50 [1.10]		
40 [1.575]	12.18 [26.86]	0.75 [1.65]		

Notes : 1.The sensor switch A and B shows the lead wire lengths.
A:1000mm [39in.] B:3000mm [118in.]

Air Flow Rate and Air Consumption

While the rodless cylinder's air flow rate and air consumption can be found through the following calculations, the quick reference table below provides the answers more conveniently.

Air flow rate: $Q_1 = \frac{\pi D^2}{4} \times L \times \frac{60}{t} \times \frac{P+0.101}{0.101} \times 10^{-6}$

Q₁ : Required air flow rate for cylinder ℓ /min(ANR)
Q₂ : Air consumption of cylinder ℓ /min(ANR)
D : Cylinder tube inner diameter mm
L : Cylinder stroke mm
t : Time required for cylinder to travel 1 stroke s
n : Number of cylinder reciprocations per minute times/min
P : Pressure MPa

Air consumption: $Q_2 = \frac{\pi D^2}{4} \times L \times 2 \times n \times \frac{P+0.101}{0.101} \times 10^{-6}$

Air flow rate: $Q_1' = \frac{\pi D'^2}{4} \times L' \times \frac{60}{t} \times \frac{P'+14.7}{14.7} \times \frac{1}{1728}$

Q₁' : Required air flow rate for cylinder ft³/min.(ANR)*
Q₂' : Air consumption of cylinder ft³/min.(ANR)*
D' : Cylinder tube inner diameter in.
L' : Cylinder stroke in.
t : Time required for cylinder to travel 1 stroke sec.
n : Number of cylinder reciprocations per minute times/min
P' : Pressure psi.

Air consumption: $Q_2' = \frac{\pi D'^2}{4} \times L' \times 2 \times n \times \frac{P'+14.7}{14.7} \times \frac{1}{1728}$

*Refer to p.54 for an explanation of ANR.

cm³ [in.³]/Reciprocation (ANR)

Bore size mm [in.]	Air pressure MPa [psi.]					
	0.2 [29]	0.3 [44]	0.4 [58]	0.5 [73]	0.6 [87]	0.7 [102]
16 [0.630]	1.198 [0.0731]	1.596 [0.0974]	1.993 [0.1216]	2.391 [0.1459]	2.789 [0.1702]	3.187 [0.1945]
25 [0.984]	2.924 [0.1784]	3.896 [0.2377]	4.867 [0.2970]	5.838 [0.3563]	6.810 [0.4156]	7.781 [0.4748]
40 [1.575]	7.486 [0.4568]	9.973 [0.6086]	12.46 [0.7604]	14.95 [0.9123]	17.43 [1.0636]	19.92 [1.2156]

The figures in the table show the air flow rate and air consumption when a rodless cylinder makes 1 reciprocation with stroke of 1mm [0.0394in.]. The air flow rate and consumption actually required are found by the following calculations.

● Finding the air flow rate (for selecting F.R.L., valves, etc.)

Example: When operating a rodless cylinder with bore size of 40mm [1.575in.] at speed of 300mm/s [11.8in./sec.] and under air pressure of 0.5Mpa [73psi.]

$$14.95 \times \frac{1}{2} \times 300 \times 10^{-3} = 2.24 \text{ ℓ/s [0.0791ft}^3\text{/sec.]} \text{ (ANR)}$$

$$\text{(At this time, the air flow rate per minute is } 14.95 \times \frac{1}{2} \times 300 \times 60 \times 10^{-3} = 134.55 \text{ ℓ/min [4.750ft}^3\text{/min.]} \text{ (ANR).)}$$

● Finding the air consumption

Example 1. When operating a rodless cylinder with bore size of 40mm [1.575in.] and stroke of 100mm [3.94in.], and under air pressure of 0.5MPa [73psi.], for 1 reciprocation

$$14.95 \times 100 \times 10^{-3} = 1.495 \text{ ℓ [0.0528ft}^3\text{]/Reciprocation (ANR)}$$

Example 2. When operating a rodless cylinder with bore size of 40mm [1.575in.] and stroke of 100mm [3.94in.], and under air pressure of 0.5MPa [73psi.], for 10 reciprocations per minute

$$14.95 \times 100 \times 10 \times 10^{-3} = 14.95 \text{ ℓ/min [0.528ft}^3\text{/min.]} \text{ (ANR)}$$

Note: To find the actual air consumption required when using rodless cylinders, add the air consumption of the piping to the air consumption obtained from the above calculation.

Order Codes of Magnet Type Rodless Cylinder

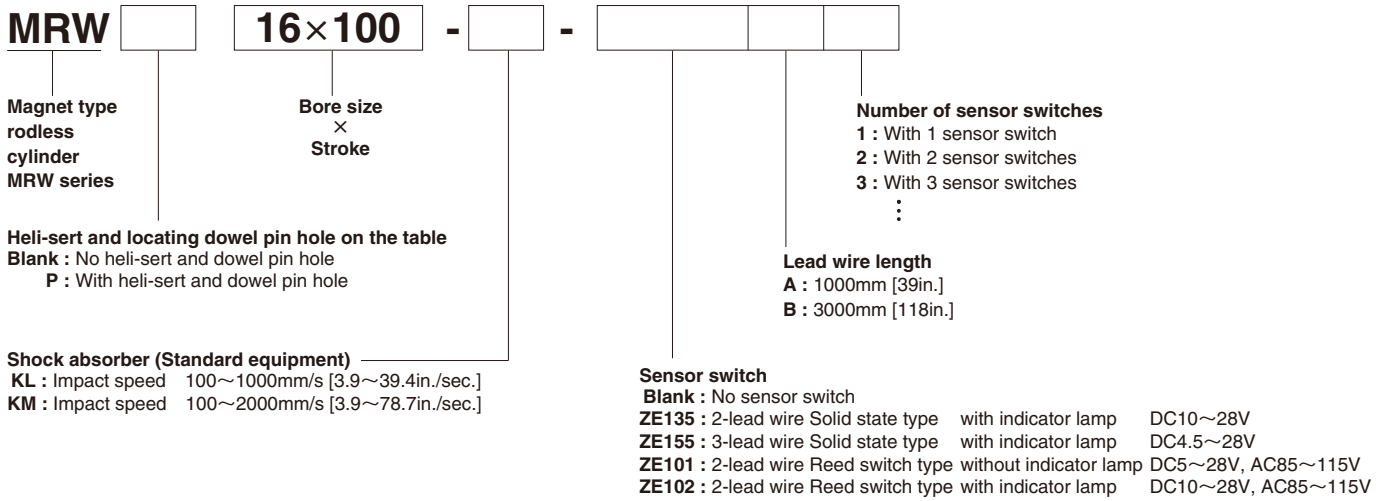

Additional Parts

● Shock absorber

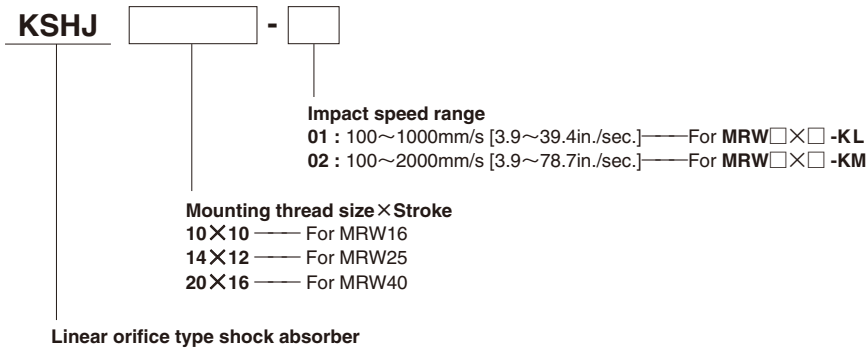

Inner Construction of Magnet Type Rodless Cylinder

MRW ($\phi 16$ [0.630in.]~ $\phi 40$ [1.575in.]

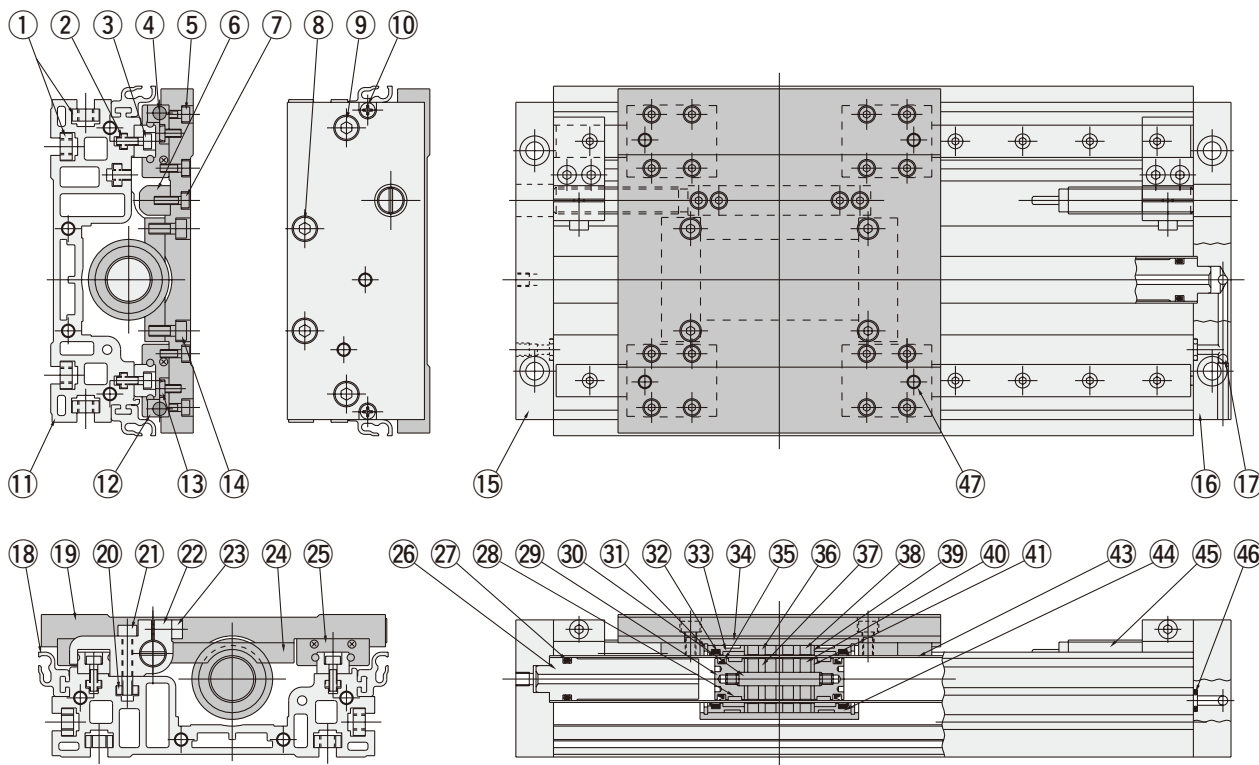

Major Parts and Materials

No.	Parts	Materials	Qty	Remarks
①	Square nut	Steel	24	Zinc plated
②	Square nut	Steel	—	Zinc plated
③	Hexagon socket head bolt	Alloy steel	—	Zinc plated
④	Sensor magnet	Rare earth magnet	2	
⑤	Hexagon socket head bolt	Alloy steel	16	Zinc plated
⑥	Stopper	Steel	1	Zinc plated
⑦	Hexagon socket head bolt	Alloy steel	4	Zinc plated
⑧	Hexagon socket head bolt	Alloy steel	6	Zinc plated
⑨	Low head cap screw	Alloy steel	2	Black oxide (Hexagon socket head bolt for $\phi 16$ and 25)
⑩	Cross recessed head tapping screw	Alloy steel	4	Zinc plated
⑪	Base	Aluminum alloy	1	Anodized
⑫	Magnet holder	Aluminum alloy	2	Anodized
⑬	Hexagon socket button head screw	Stainless steel	2	Hexagon socket head bolt for $\phi 25$ and 40
⑭	Hexagon socket head bolt	Alloy steel	4	Zinc plated
⑮	End plate L	Aluminum alloy	1	Anodized
⑯	End plate R	Aluminum alloy	1	Anodized
⑰	Steel ball	Steel	2	
⑱	Sensor rail	Aluminum alloy	2	Anodized
⑲	Table	Aluminum alloy	1	Anodized
⑳	Holder nut	Steel	2	Zinc plated
㉑	Hexagon socket head bolt	Alloy steel	4	Zinc plated
㉒	Attachment holder	Aluminum alloy	2	Anodized
㉓	Hexagon socket head bolt	Alloy steel	2	Zinc plated
㉔	Slide stopper	Aluminum alloy	2	Anodized (1pc. for $\phi 40$ [1.575in.])

No.	Parts	Materials	Qty	Remarks
㉕	Linear guide	—	2	
㉖	End pipe	Aluminum alloy	2	
㉗	O-ring	Synthetic rubber (NBR)	2	
㉘	Inner wear ring	Special plastic	2	
㉙	Piston	Aluminum alloy	1	
㉚	Shaft	Stainless steel	1	
㉛	Snap ring	Spring steel	2	
㉜	Scraper	Synthetic rubber (NBR)	2	
㉝	Outer wear ring	Special plastic	2	
㉞	Slider	Aluminum alloy	1	Anodized
㉟	Piston seal	Synthetic rubber (NBR)	2	
㊱	Outer yoke A	Steel	3	Nickel plated
㊲	Inner yoke A	Steel	3	Nickel plated
㊳	Outer magnet	Rare earth magnet	4	
㊴	Outer yoke B	Steel	2	Nickel plated
㊵	Inner magnet	Rare earth magnet	4	
㊶	Inner yoke B	Steel	2	Nickel plated
㊷	Cylinder tube	Aluminum alloy	1	
㊸	Holder	Aluminum alloy	2	Anodized
㊹	Shock absorber	—	2	
㊺	O-ring	Synthetic rubber (NBR)	2	
㊻	Heli-sert	Stainless steel	(4)	Optional

Dimensions of Magnet Type Rodless Cylinder MRW 16 (mm)

●MRW ×

CAD MRW16

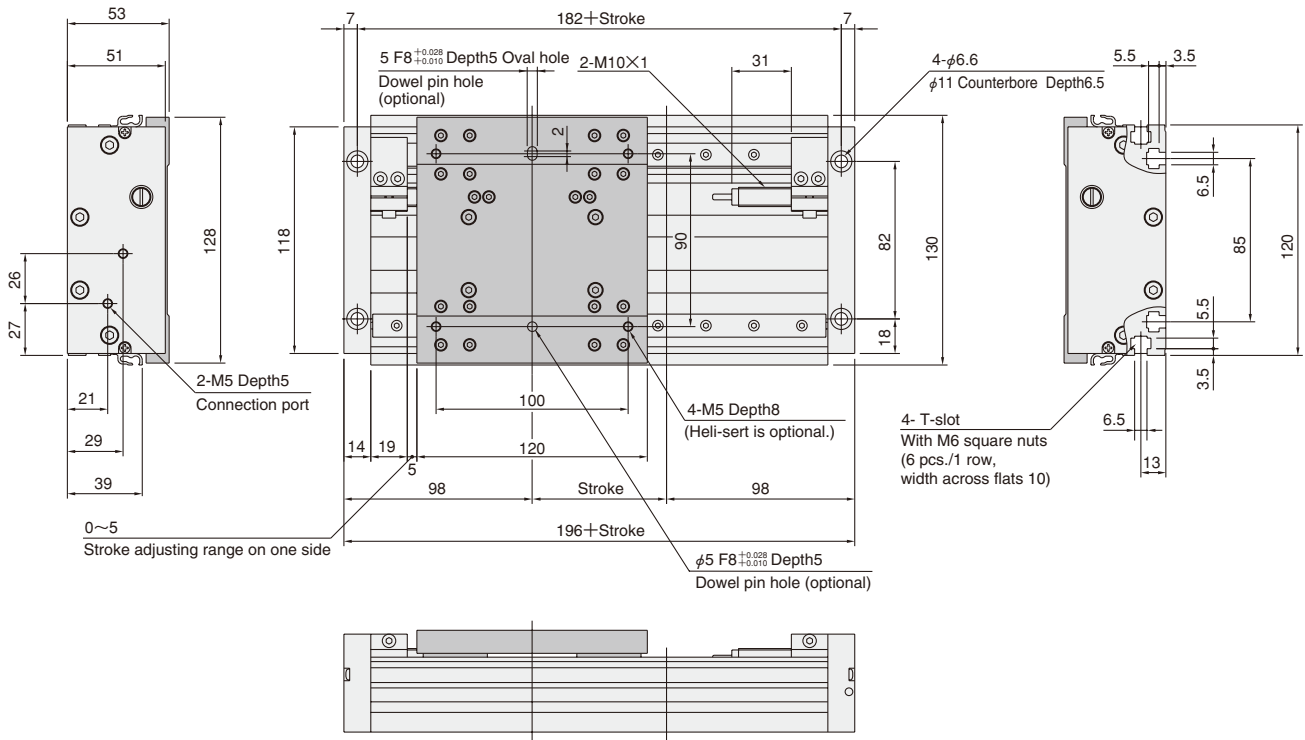

Dimensions of Magnet Type Rodless Cylinder MRW 25 (mm)

●MRW ×

CAD MRW25

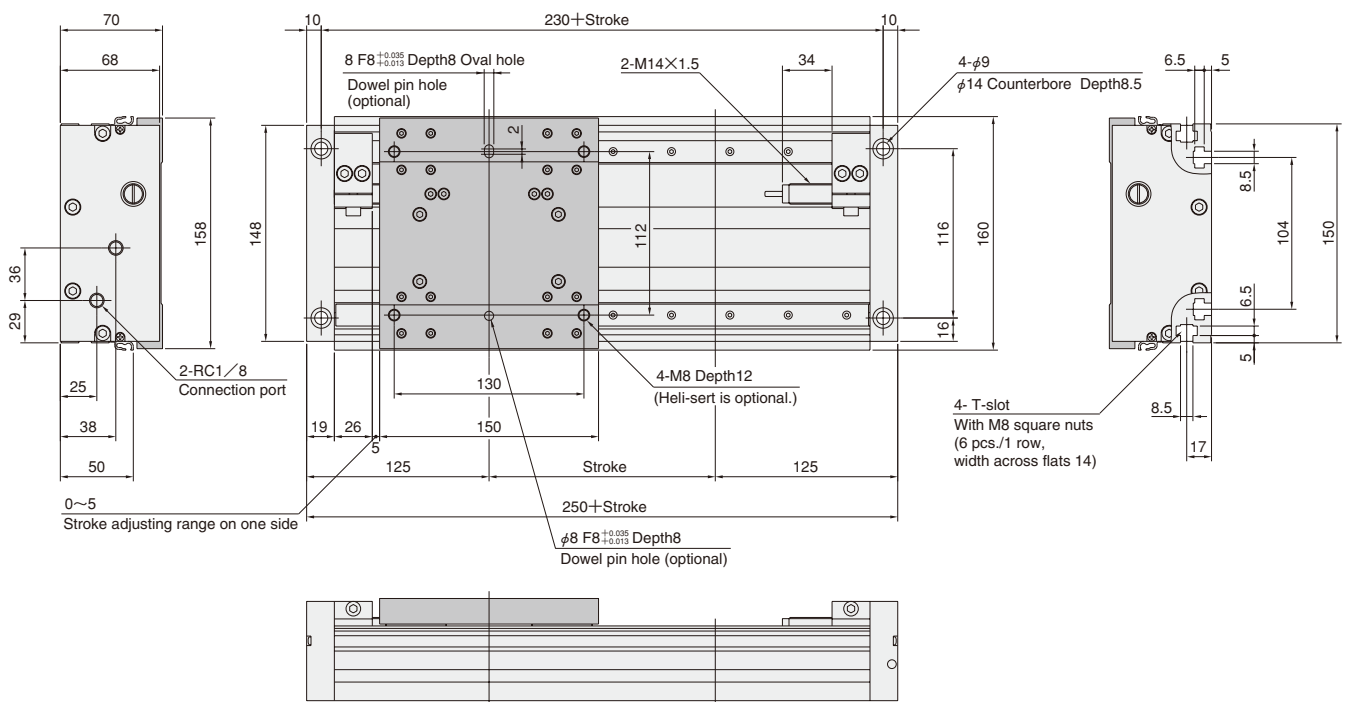

SENSOR SWITCHES

Solid State Type, Reed Switch Type

Symbol

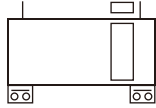

Order Codes

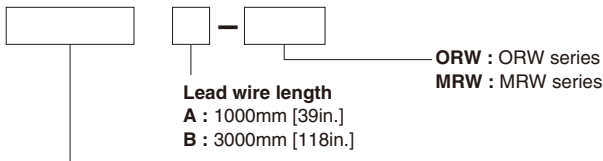

Sensor switch

ZE135 : Solid state type with indicator lamp DC10V~28V Horizontal lead wire
ZE101 : Reed switch type without indicator lamp DC5V~28V Horizontal lead wire
AC85~115V

ZE155 : Solid state type with indicator lamp DC4.5V~28V Horizontal lead wire
ZE102 : Reed switch type with indicator lamp DC10V~28V Horizontal lead wire
AC85~115V

● For details of sensor switches, see p.1544.

Moving Sensor Switch

Loosening the sensor switch's mounting screw allows the sensor switch to be moved along the switch mounting groove on the base.

It is possible to insert the lead wire into the groove.

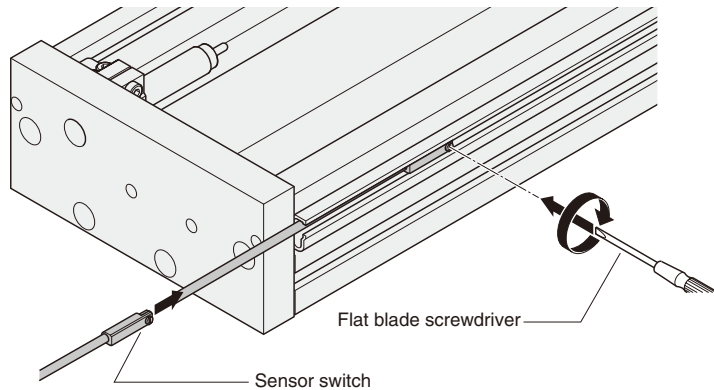

● Tighten the mounting screw with a tightening torque of 20~30N·cm [1.8~2.7in·lbf].

Mounting Location of End of Stroke Detection Sensor Switch

mm [in.]

When the sensor switch is mounted in the locations shown to the right, the magnet comes to the maximum sensing location of the sensor switch at the end of the stroke.

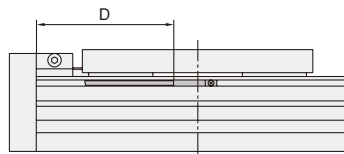
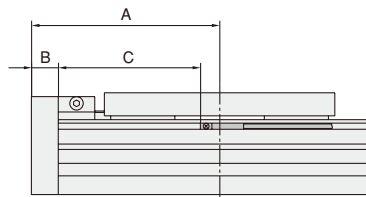

● Solid state type (ZE135, ZE155)

Model	A	B	C	D
ORW16, MRW16	98 [3.858]	14 [0.551]	78 [3.071]	74.5 [2.933]
ORW25, MRW25	125 [4.921]	19 [0.748]	100 [3.937]	96.5 [3.799]
ORW40, MRW40	165 [6.496]	22 [0.866]	137 [5.394]	133.5 [5.256]

● Reed switch type (ZE101, ZE102)

Model	A	B	C	D
ORW16, MRW16	98 [3.858]	14 [0.551]	74 [2.913]	71.5 [2.815]
ORW25, MRW25	125 [4.921]	19 [0.748]	96 [3.780]	93.5 [3.681]
ORW40, MRW40	165 [6.496]	22 [0.866]	133 [5.236]	130.5 [5.138]

Special Rodless Cylinders in ORW and MRW Series

For the rodless cylinders **ORW** and **MRW** series, we have targeted certain special models that have proven to be particularly popular as semi-standard products.

To order, enter codes in parentheses () at the end of the order code.

As we expand our special product range, we hope you will continue to incorporate new models into your work.

For detailed specifications, dimensions, and delivery schedules, consult us.

1. Clean room-compatible grease specification (-1002W)

For MRW series only

Uses a low-volatility, low particle generation grease. The linear guide uses a standard grease, however.

2. Low-speed and speed-variable specification (-1003W)

Effective for operations that involve repeated stops and starts, and for constant low-speed operations.

Operating speed range 20~100mm/s [0.8~3.9in./sec.]

3. Simplified clean room specification (-1014W)

For MRW series only

The linear guide is Raydent-treated, while the bolts and screws are stainless steel or nickel-plated. Moreover, the grease used is a low particle generation grease. The items are not packaged in the clean rooms, however. And the shock absorber is not available for the clean room specification.

Order example :
For simplified clean room specification
●ORWP16×300-KL-1014W

Note: These special specifications may vary from standard items in delivery, prices, dimensions, life cycles, etc. Confirm us the details before ordering.

Moreover, consult us about similar settings available in other rodless cylinder series.