

KOGANEI

ACTUATORS GENERAL CATALOG



ROTARY ACTUATORS PISTON TYPE **HRAP SERIES** CONTENTS

Features	1223
Specifications	1224
Inner Construction, Major Parts and Materials	1226
Order Codes	1227
Dimensions	1228
Sensor Switches	1230
Handling Instructions and Precautions	1231

ROTARY ACTUATORS PISTON TYPE RAP SERIES



Caution

Before use, be sure to read the "Safety Precautions" on p. 57.





Rotary actuator piston type for swing motion offers efficient use of space.

HRAP Series

A 360° swing angle specification has been added to the series.

The □4mm [0.157in.] compact sensor switch is now mountable for improved convenience.

■ Wide variation offers 4 kinds of torque and 5 kinds of swing angles.

<p>HRAP1</p> <p>● Nominal torque 0.098N·m [0.072ft·lbf]</p> 	<p>HRAP5</p> <p>● Nominal torque 0.49N·m [0.36ft·lbf]</p> 
<p>HRAP10</p> <p>● Nominal torque 0.981N·m [0.72ft·lbf]</p> 	<p>HRAP20</p> <p>● Nominal torque 1.961N·m [1.45ft·lbf]</p> 

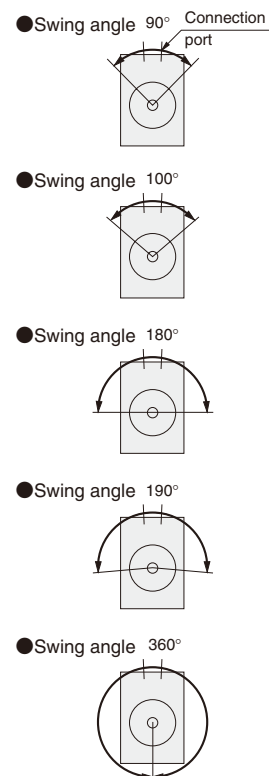

■ Koganei's own original double-rack method achieves a no-backlash and no-leak construction.

No backlash is obtained by a rack constantly pushed at the end of the swing. Moreover, use of a separate-type piston construction that avoids interference with the loads caused by the backpressured rack, etc., means no air leakage.

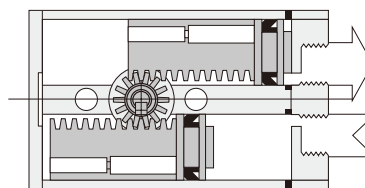

■ Square type emphasizes space efficiency; trim body design allows for single-plane piping.

Easily mountable square body and piping concentrated in a single plane result in high space efficiency.

■ Optional settings further expand the range of rotary actuator applications.



The □4mm [0.157in.] compact sensor switch can easily detect the position of the end of the swing. The sensor switch is available in the solid state type and reed switch type.



A double rod specification and stainless rod specification are also available.

ROTARY ACTUATORS

Symbol

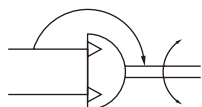

Specifications

Model		HRAP□1	HRAP□5	HRAP□10	HRAP□20
Item					
Operation type		Double acting piston type (Rack and pinion construction)			
Effective torque ^{Note1}	N·m [ft·lbf]	0.078 [0.058]	0.373 [0.275]	0.883 [0.651]	1.863 [1.374]
Swing angle (Tolerance $+10^\circ$)	RAP□-90	90°			
	RAP□-100	100°			
	RAP□-180	180°			
	RAP□-190	190°			
	RAP□-360	360°			
Media		Air			
Port size		10-32 UNF	NPT1/8		
Rod diameter	mm [in.]	4 [0.157]	6 [0.236]	8 [0.315]	10 [0.394]
Operating pressure range	MPa [psi.]	0.15~0.7 [22~102]		0.06~0.7 [9~102]	
Proof pressure	MPa [psi.]	1.03 [149]			
Operating temperature range	°C [°F]	0~50 [32~122]			
Allowable energy	J [in·lbf]	0.001 [0.009]	0.003 [0.027]	0.008 [0.071]	0.015 [0.133]
Allowable radial load	N [lbf.]	1.5 [0.34]	2.5 [0.56]	4.3 [0.97]	8.0 [1.80]
Allowable thrust load ^{Note2}	N [lbf.]	0.08 [0.018]	0.13 [0.029]	0.22 [0.049]	0.40 [0.090]
Lubrication		Not required			
Cushion		None			

Notes: 1. Values are obtained when the air pressure is 0.5MPa [73psi].

2. Numerical values are reference values, not guaranteed values. For details, see p.1231.

Mass

Model	Main body mass	Additional mass	
		Double rod specification	With sensor switch specification
HRAP1-90,100	83 [2.93]	2 [0.07]	With 1 sensor switch: 24 [0.85] With 2 sensor switches: 46 [1.59]
HRAP1-180,190	101 [3.56]		
HRAP1-360	148 [5.22]		
HRAP5-90,100	212 [7.48]	4 [0.14]	
HRAP5-180,190	260 [9.17]		
HRAP5-360	375 [13.23]		
HRAP10-90,100	300 [10.58]	10 [0.35]	
HRAP10-180,190	380 [13.40]		
HRAP10-360	538 [18.98]		
HRAP20-90,100	500 [17.64]	16 [0.56]	
HRAP20-180,190	614 [21.66]		
HRAP20-360	870 [30.69]		

Calculation example: Mass of HRAP1-180 with double rod and 1 sensor switch;
 $101+2+24=127\text{g}$ [4.48oz.]

- Notes: 1. The additional mass of the sensor switch is the mass of the sensor holder and the sensor body only, and does not include the lead wire mass.
 2. The mass remains the same even with different materials for the rod.

Output Characteristic (Effective Torque)

● HRAP□1, HRAP□5

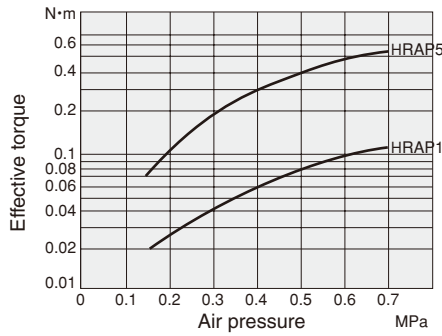

● HRAP□10, HRAP□20

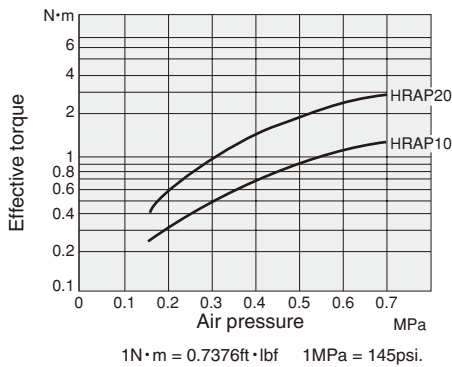

Air Flow Rate and Air Consumption

● HRAP□1, HRAP□5

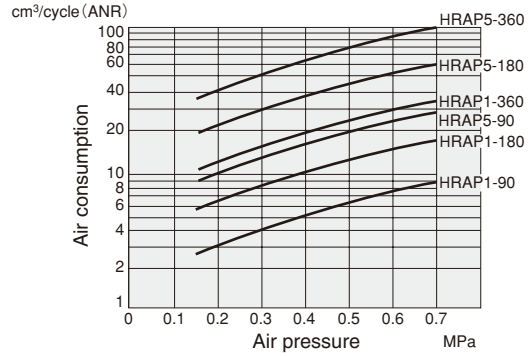

● HRAP□10, HRAP□20

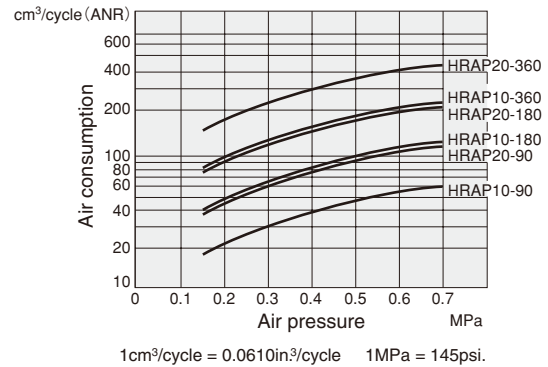

● Effective torque

N·m [ft·lbf]

Model	Air pressure MPa [psi.]					
	0.2 [29]	0.3 [44]	0.4 [58]	0.5 [73]	0.6 [87]	0.7 [102]
HRAP1	0.025 [0.018]	0.042 [0.031]	0.060 [0.044]	0.078 [0.058]	0.096 [0.071]	0.108 [0.080]
HRAP5	0.108 [0.080]	0.196 [0.145]	0.284 [0.209]	0.373 [0.275]	0.451 [0.333]	0.539 [0.398]
HRAP10	0.294 [0.217]	0.441 [0.325]	0.657 [0.485]	0.883 [0.651]	1.108 [0.817]	1.334 [0.984]
HRAP20	0.588 [0.434]	0.981 [0.724]	1.422 [1.049]	1.863 [1.374]	2.295 [1.693]	2.746 [2.025]

● Cylinder bore size and stroke

mm [in.]

Model	HRAP□1	HRAP□5	HRAP□10	HRAP□20
	Swing angle			
90°	10×7.2 [0.394×0.283]	16×9.5 [0.630×0.374]	20×12.6 [0.787×0.496]	25×15.7 [0.984×0.618]
100°	10×8.0 [0.394×0.315]	16×10.6 [0.630×0.417]	20×14.0 [0.787×0.551]	25×17.5 [0.984×0.689]
180°	10×14.4 [0.394×0.567]	16×19.0 [0.630×0.748]	20×25.2 [0.787×0.992]	25×31.4 [0.984×1.236]
190°	10×15.2 [0.394×0.598]	16×20.1 [0.630×0.791]	20×26.5 [0.787×1.043]	25×33.2 [0.984×1.307]
360°	10×28.8 [0.394×1.134]	16×38.0 [0.630×1.496]	20×50.4 [0.787×1.984]	25×62.8 [0.984×2.472]

Calculation of air flow rate and air consumption

The top-right graphs show the air consumption during 1 cycle of the rotary actuator.

The actual air flow rate and consumption required can be found through the following calculations.

● Finding the air flow rate

(For selecting F.R.L., valves, etc.)

$$Q_1 = \frac{\pi D^2}{4} \times L \times \frac{60}{t} \times \frac{P+0.1013}{0.1013} \times 10^{-6}$$

$$\text{or } Q_1 = q \times \frac{60}{t} \times \frac{P+0.1013}{0.1013} \times 10^{-6}$$

● Finding the air consumption

$$Q_2 = \frac{\pi D^2}{4} \times L \times 2 \times n \times \frac{P+0.1013}{0.1013} \times 10^{-6}$$

$$\text{or } Q_2 = q \times 2 \times n \times \frac{P+0.1013}{0.1013} \times 10^{-6}$$

Q_1 : Air flow rate ℓ/min (ANR)

Q_2 : Air consumption ℓ/min (ANR)

D : Cylinder bore size mm

L : Cylinder stroke mm

q : Cylinder internal capacity (one side cylinder only) mm³

t : Time required for cylinder to travel 1 stroke s

n : Number of cylinder reciprocations per minute times/min

P : Pressure MPa

● Finding the air flow rate

(For selecting F.R.L., valves, etc.)

$$Q_1' = \frac{\pi D'^2}{4} \times L' \times \frac{60}{t} \times \frac{P'+14.696}{14.696} \times \frac{1}{1728}$$

$$\text{or } Q_1' = q' \times \frac{60}{t} \times \frac{P'+14.696}{14.696} \times \frac{1}{1728}$$

● Finding the air consumption

$$Q_2' = \frac{\pi D'^2}{4} \times L' \times 2 \times n \times \frac{P'+14.696}{14.696} \times \frac{1}{1728}$$

$$\text{or } Q_2' = q' \times 2 \times n \times \frac{P'+14.696}{14.696} \times \frac{1}{1728}$$

Q_1' : Air flow rate ft³/min (ANR)*

Q_2' : Air consumption ft³/min (ANR)*

D' : Cylinder bore size in.

L' : Cylinder stroke in.

q' : Cylinder internal capacity (one side cylinder only) in³

t : Time required for cylinder to travel 1 stroke sec.

n : Number of cylinder reciprocations per minute times/min.

P' : Pressure psi.

* Refer to p.54 for an explanation of ANR.

Inner Construction and Major Parts

● Standard specification

HRAP□1, HRAP□5

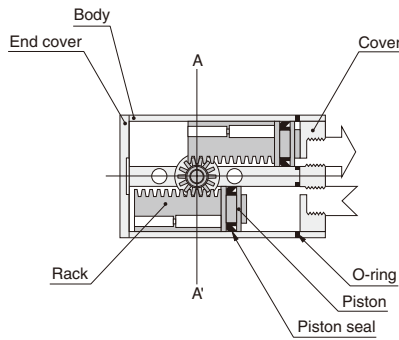

Section A-A'

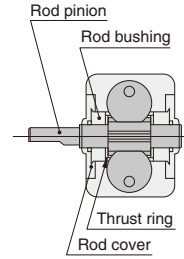

HRAP□10, HRAP□20

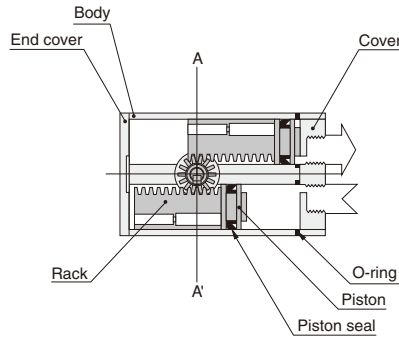

Section A-A'

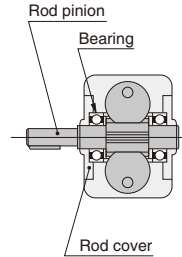

● With magnet specification

HRAPS□□

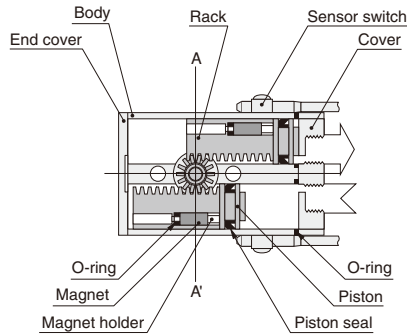

Section A-A'

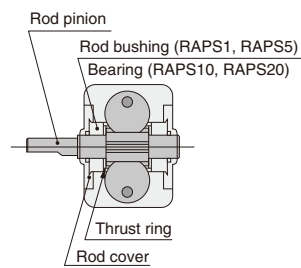

Major Parts and Materials

Parts	Materials
Main body	Aluminum (anodized)
Rod pinion	Steel (S45C) or stainless steel (SUS304)
Rack	Plastic
Piston	
Piston seal	Synthetic rubber (NBR)







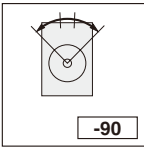
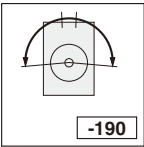

Seals

Model	Item	O-ring	Piston seal
	Q'ty		
HRAP□1		IN10	PPY-10
HRAP□5		IN16	PPY-16
HRAP□10		IN20	PPY-20
HRAP□20		I.D φ 25 × φ 1.5	PPY-25

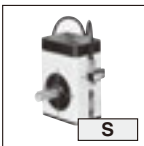
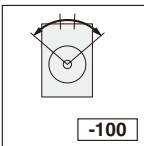
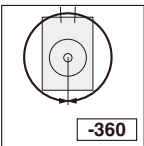
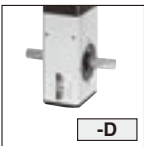
HRAP, HRAPS

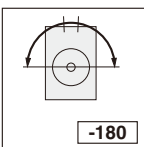
Rotary Actuator Piston Type

Order Codes

Specification	Nominal torque	Swing angle	Rod type	Rod material	Sensor switch			
<p>Standard specification</p>  <p>Blank</p>	<ul style="list-style-type: none"> ● 1 : 0.098N·m [0.072ft·lbf] ● 5 : 0.49N·m [0.36ft·lbf] ● 10 : 0.981N·m [0.72ft·lbf] ● 20 : 1.961N·m [1.45ft·lbf] 	<p>90°</p>  <p>-90</p> <p>190°</p>  <p>-190</p>	<p>Single rod type</p>  <p>Blank</p>	<p>Blank : Steel S : Stainless steel</p>	<p>No sensor switch</p>  <p>Blank</p>			
<p>With magnet specification</p>  <p>S</p>		<p>100°</p>  <p>-100</p> <p>360°</p>  <p>-360</p>	<p>Double rod type</p>  <p>-D</p>		<p>With ZC130</p>  <p>-ZC130</p> <ul style="list-style-type: none"> ● Solid state type ● With indicator lamp ● DC10~28V ● 2-lead wire 			
<p>Note: Magnet for sensor switch is not built into the standard specification.</p>		<p>180°</p>  <p>-180</p>			<p>With CS5T</p>  <p>-CS5T</p> <ul style="list-style-type: none"> ● Reed switch type ● Without indicator lamp ● DC5~28V ● AC85~115V 			
					<p>With ZC153</p>  <p>-ZC153</p> <ul style="list-style-type: none"> ● Solid state type ● With indicator lamp ● DC4.5~28V ● 3-lead wire 			
					<p>With CS11T</p>  <p>-CS11T</p> <ul style="list-style-type: none"> ● Reed switch type ● With indicator lamp ● DC10~28V 			
Basic model								
HRAP	S	1 5 10 20	-90 -100 -180 -190 -360	-D	S	-ZC130 -ZC153 -CS5T -CS11T	A B	1 2

● Lead wire length
A : 1000mm [39in.]
B : 3000mm [118in.]
 Number of sensor switches
 1: With 1 sensor switch
 2: With 2 sensor switches

● For the order codes of sensor switches only, see p.1230.

Dimensions of HRAP □ 1 (mm)

HRAP □ 1- Swing angle

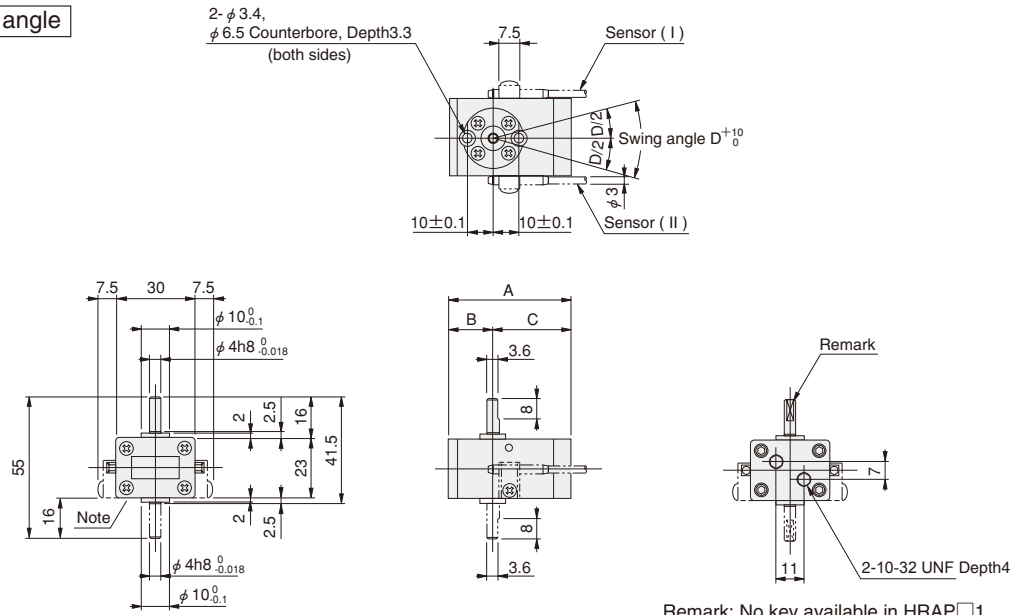

Remark: No key available in HRAP □ 1.
Note: A counterbore for machining process is located here.
It does not hinder use of the product.

Code	A	B	C	D
Model				
HRAP □ 1-90	48	17	31	90
HRAP □ 1-100				100
HRAP □ 1-180	60	23	37	180
HRAP □ 1-190				190
HRAP □ 1-360	88	37	51	360

Dimensions of HRAP □ 5 (mm)

HRAP □ 5- Swing angle

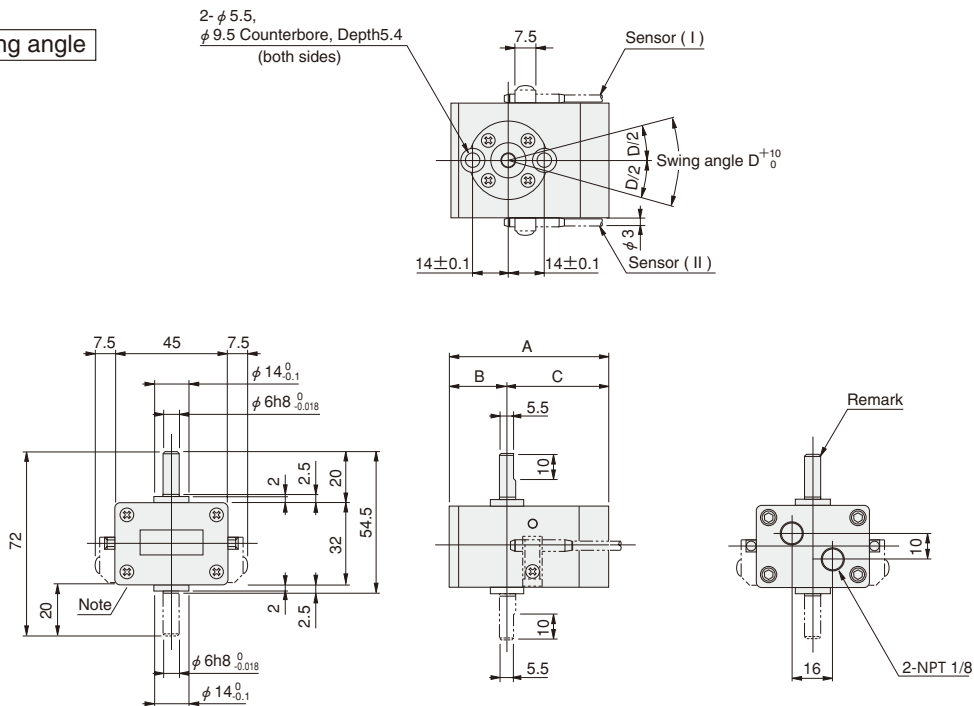

Remark: No key available in HRAP □ 5.
Note: A counterbore for machining process is located here.
It does not hinder use of the product.

Code	A	B	C	D
Model				
HRAP □ 5-90	62	22.5	39.5	90
HRAP □ 5-100				100
HRAP □ 5-180	78	27.5	50.5	180
HRAP □ 5-190				190
HRAP □ 5-360	116	47	69	360

Dimensions of HRAP □ 10 (mm)

HRAP □ 10- Swing angle

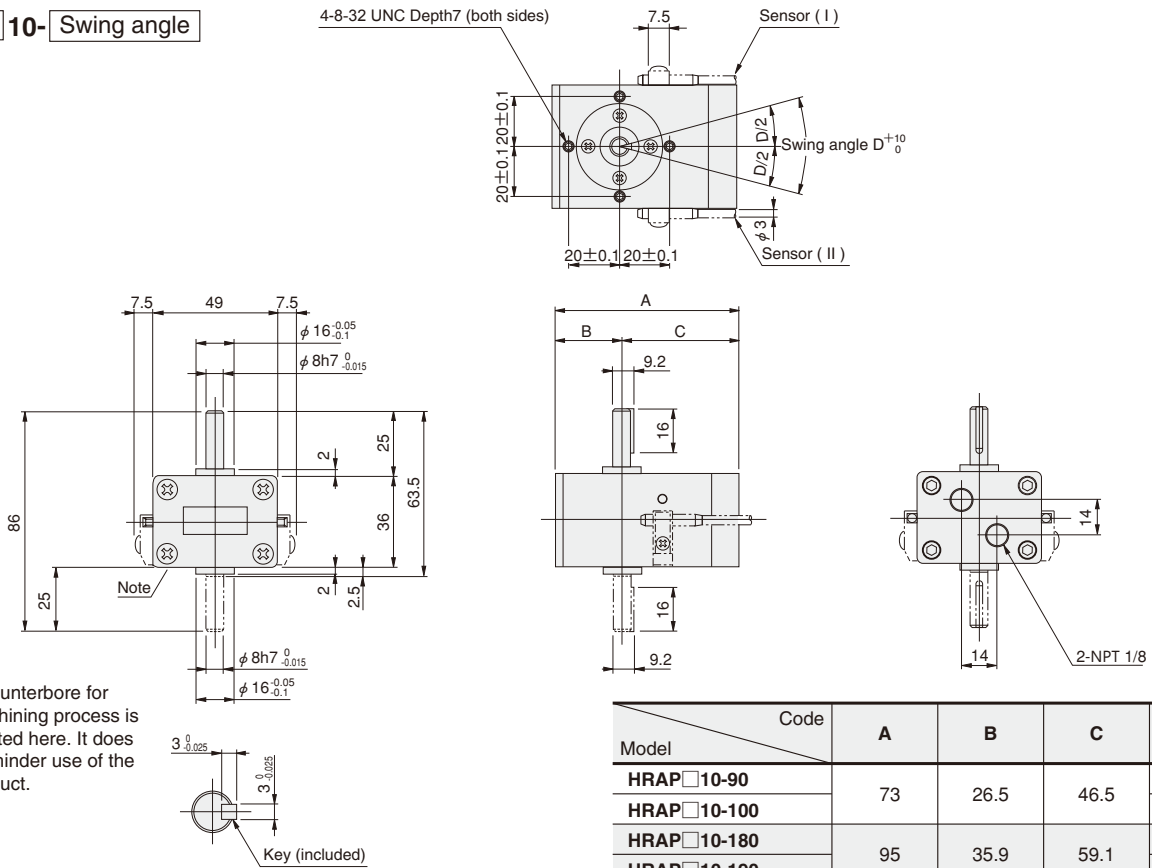

Note: A counterbore for machining process is located here. It does not hinder use of the product.

Dimensions of HRAP □ 20 (mm)

HRAP □ 20- Swing angle

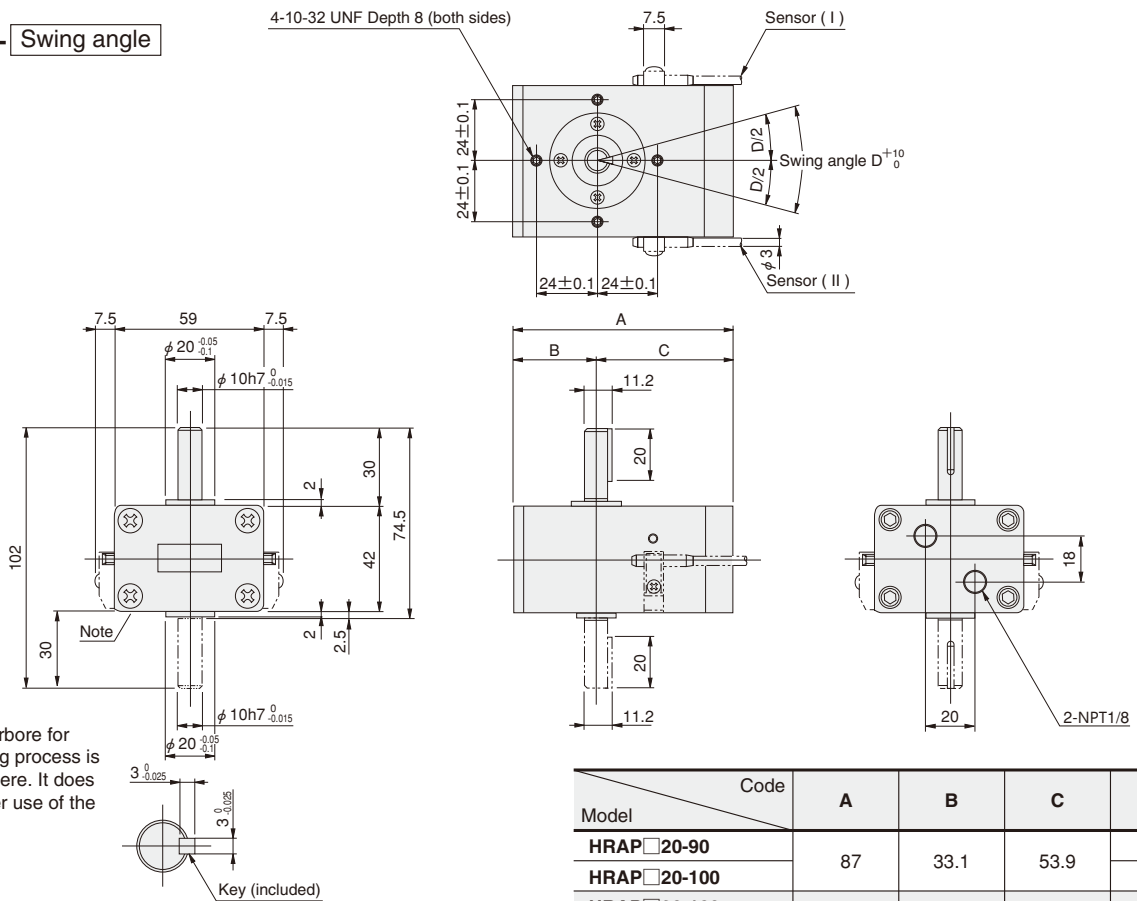

Note: A counterbore for machining process is located here. It does not hinder use of the product.

SENSOR SWITCHES

Solid State Type, Reed Switch Type

Order Codes for Sensor Switches

				Sensor switch model	Lead wire length	Holder/nominal torque
Solid state type	2-lead wire	with indicator lamp	DC10~28V	ZC130	A B	-RAPS
Solid state type	3-lead wire	with indicator lamp	DC4.5~28V	ZC153		
Reed switch type	2-lead wire	without Indicator lamp	DC5~28V AC85~115V	CS5T		
Reed switch type	2-lead wire	with indicator lamp	DC10~28V	CS11T		

● For details of sensor switches, see p.1544.

● Order codes for holder only

C1-RAPS



Nominal torque

- 1
- 5
- 10
- 20

- A : 1000mm [39in.]
- B : 3000mm [118in.]

- Blank : No holder
- RAPS: With holder

- Blank : No holder
- 1 : For RAPS1
- 5 : For RAPS5
- 10 : For RAPS10
- 20 : For RAPS20

Note: If ordering with holder, enter the nominal torque.

Swing End Detection and Mounting Location of Sensor Switch

When the sensor switch is mounted in the location shown in the diagram, the magnet comes to the maximum sensing location of the sensor switch at the end of the swing. At this time, the sensor switch A operates at the end of the swing in the A direction, and sensor switch B operates at the end of the swing in the B direction.

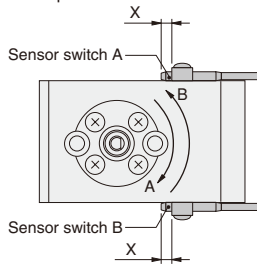

- Notes: 1. Do not mount the sensor switch in the reverse direction.
2. When an external stopper, etc., restricts the swing angle, note that there may be cases where the sensor switch does not operate within the above adjusting range.

Model	X : Maximum sensing location mm [in.]		
	ZC130, ZC153	CS5T	CS11T
HRAPS1	6.5 [0.256]	5.0 [0.197]	8.5 [0.335]
HRAPS5	7.0 [0.276]	5.5 [0.217]	9.0 [0.354]
HRAPS10	6.5 [0.256]	5.0 [0.197]	8.5 [0.335]
HRAPS20			

Sensor Switch Operating Range and Response Differential

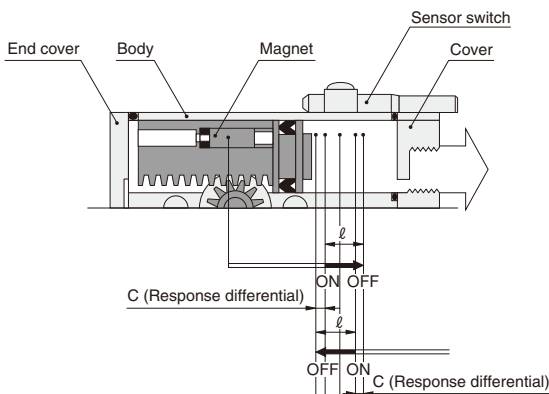

CS5T □		CS11T □		ZC1 □ □ □	
Operating range ℓ	Response differential C	Operating range ℓ	Response differential C	Operating range ℓ	Response differential C
4.7~10.8 [0.185~0.425]	1.4 [0.055] or less	6.8~9.5 [0.268~0.374]	1.4 [0.055] or less	1.5~4.7 [0.059~0.185]	0.3 [0.012] or less

Remark: The above table shows reference values.

Reference

- When use of an external stopper restricts the swing angle, 2 sensor switches can be used up to the angle (α) shown below. The recommended type of the sensor switch is a solid state sensor switch for its short operating range.

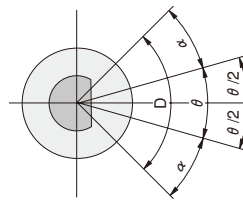

- D : Swing angle
- θ : Range where sensor switch cannot detect
- α : Range where sensor switch can detect

Model	Swing angle	θ Note	α
HRAPS1	90°	56°	17°
	100°		22°
	180°		62°
	190°		67°
	360°		130°
HRAPS5	90°	42°	24°
	100°		29°
	180°		69°
	190°		74°
	360°		170°
HRAPS10	90°	32°	29°
	100°		34°
	180°		70°
	190°		75°
	360°		220°
HRAPS20	90°	26°	32°
	100°		37°
	180°		50°
	190°		55°
	360°		250°

Note: Two sensor switches may be ON at the same time when the angle adjustment is set to this value or below.

Remark: For the use of reed switch type sensor switches, or for swing starting points other than those listed above, consult us.

● Caution when installing a sensor switch on the actuator

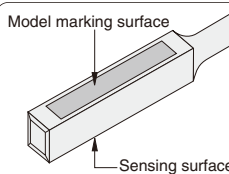

In the ZC type sensor switches, the opposite side from the model marking surface is the sensing surface side. Mount it so that the cylinder magnet comes to the sensing surface side.

Handling Instructions and Precautions



Selection and installation

Selection

- When selecting a model, calculate the torque and kinetic energy according to "Model Selection Procedure" on p.43 to p.52.
The inertia load becomes larger when the load mass is large, or during high operating speeds, and it may exceed the rotary actuator's allowable kinetic energy. In this case, install a shock absorber to prevent the rotary actuator from being directly applied to inertia force.
- The positional relationship between the swing angle and the key (or flat surface of the rod) is as shown in the diagram below. Even though the swing angle allowance is within the range of specification angles, install an external stopper, etc., to maintain accurate positioning.

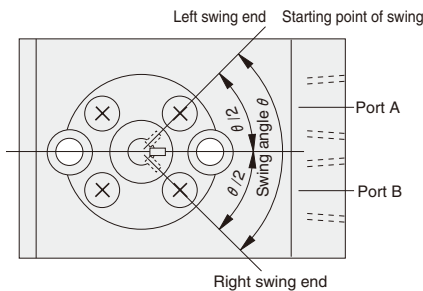

When pressure is supplied through Port A, the rod rotates to the left (counterclockwise direction), and when pressure is supplied through Port B, the rod rotates to the right (clockwise direction).

- For the swing time of the rotary actuator (the time it takes to reach the swing end from beginning a start), see the table below as a guide.

● Swing time at air pressure 0.5MPa with no load _s

Model	Swing angle				
	90°	100°	180°	190°	360°
HRAP□1					0.3~0.6
HRAP□5	0.2~0.5		0.3~1.0		0.3~0.8
HRAP□10					0.3~1.0
HRAP□20	0.2~2.0		0.3~2.0		0.4~1.2

- Notes
- Excessively high kinetic energy could damage the rod of the rotary actuator. Always use within the allowable energy.
 - For details about kinetic energy, see Koganei's "Criteria for Selection."

Installation

- While any mounting direction is allowed, avoid application that apply the load on the axial direction (thrust). Install external devices, such as bearings, to receive thrust load.
- Install a rotary actuator so that the rotation center of the load align with the rotary actuator's rod center. When the rotation center cannot align with the rod center, or when moment is applied to the end of the rod, use a flexible coupling or other devices to carry a rotating force only.

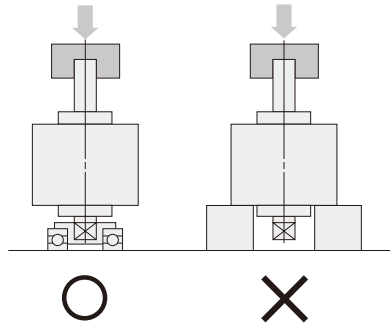

Note : Since thrust load, load moment, eccentricity of the rotating rod, or an excessive inertia load, will cause defective rotary actuator operation, or damage to the rod, always take appropriate counter-measures. Moreover, consult us about HRAP□1 and HRAP□5 bearing specifications.



General precautions

Piping

Always thoroughly blow off (use compressed air) the tubing before connecting it to the rotary actuator. Entering metal chips, sealing tape, rust, etc., generated during piping work could result in air leaks or other defective operation.

Atmosphere

- If using in locations subject to dripping water, dripping oil, etc., or to large amounts of dust, use a cover to protect the unit.
- The product cannot be used when the media or ambient atmosphere contains any of the substances listed below.
Organic solvents, phosphate ester type hydraulic oil, sulphur dioxide, chlorine gas, or acids, etc.

Lubrication

The product can be used without lubrication, if lubrication is required, use Turbine Oil Class 1 (ISO VG32) or equivalent.
Avoid using spindle oil or machine oil.

Media

- Use air for the media. For the use of any other media, consult us.
- Air used for the rotary actuator should be clean air that contains no deteriorated compressor oil, etc.
- Install an air filter (filtration of a minimum 40 μm) near the rotary actuator or valve to remove collected liquid or dust. In addition, drain the air filter periodically.