

# SOLENOID VALVES EA, EB SERIES INDEX

SOLENOID VALVES EA, EB SERIES

Features	103
Product Range	104
Handling Instructions and Precautions	105
EA Series	
Specifications	109
Order Codes	113
Dimensions	116
EB Series	
Specifications	121
Order Codes	125
Dimensions	128

Small, easy-to-use, simple construction valves!  
 Suitable for various needs and offering high-performance control, while achieving still lower power consumption and quicker response!

## New Standard Valve SOLENOID VALVES EA, EB SERIES

### SOLENOID VALVES EA series

(2, 3, 5-port pilot type solenoid valves)

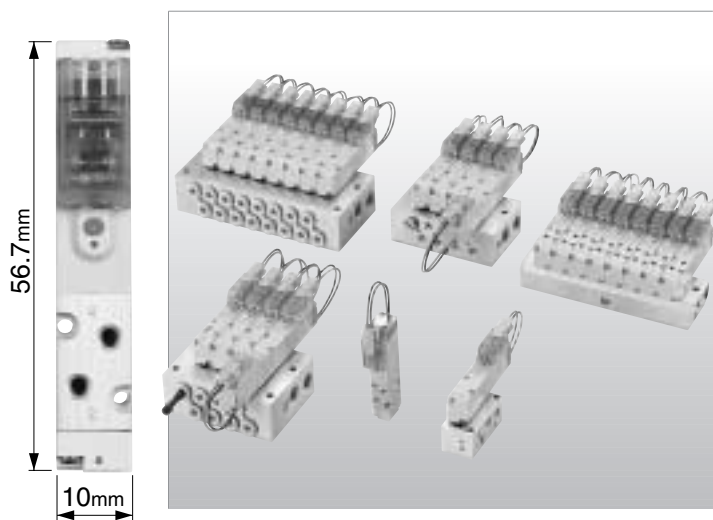

Provides reliable performance for all situations in which solenoid valves are required, in the manufacturing lines, in machinery, or in equipment.  
 A NEW standard in compact valves!

● **Space Saving—Thin and compact size**

Valve width: 10mm [0.394in.]  
 Valve length: 56.7mm [2.232in.] (EA series)  
 53mm [2.087in.] (EB series)  
 (for standard type)

● **Flow—Efficient flow rate**

Sonic conductance C: 0.26dm<sup>3</sup>/(s·bar)  
 (Effective area: 1.3mm<sup>2</sup> [Cv: 0.07])  
 Optimum for pilot-operated valves, and for operating up to  $\phi$  25 [0.984in.] bore size cylinders.

● **Response—Fast response time**

Response time: When ON, 6ms or below  
 When OFF, 7ms or below  
 (in the case of quick response type single solenoids)

● **Power—Lower power consumption**

Standard type: 0.55W, Low current type: 0.15W

● **Reliability—Improved reliability**

New solenoid and stem construction resulting from years of our valve technology experience have boosted operating life, response, and other basic performance features.

● **Environmental Protection—Improved performance**

Grommet type valves offer moisture proof specifications.



### SOLENOID VALVES EB series

(2, 3-port pilot type solenoid valves)

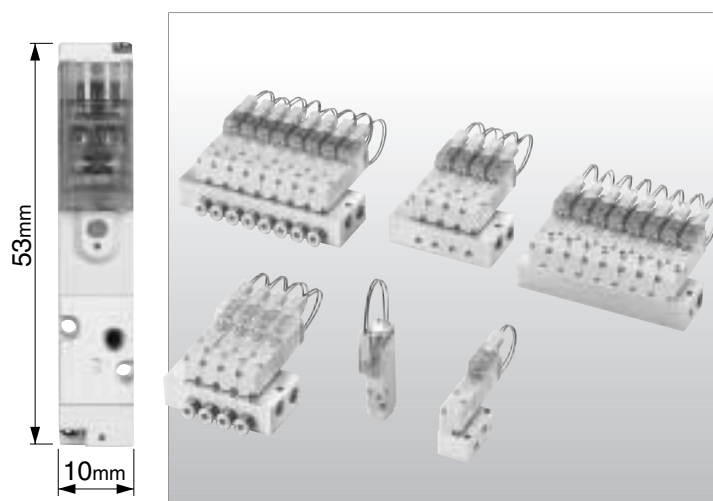

—Product Variety—  
**Providing a wide product range**

**Solenoid Valves EA Series**

**Solenoid Valves EB Series (2, 3-port valves)**

**Single unit (direct piping)**

Single solenoid

Double solenoid

EA10□F5

EA10□F6

116

Normally closed (NC)

Normally open (NO)

EB10□F1  
EB10□F3

EB10□F2  
EB10□F4

128

**Single unit (base piping)**

Single solenoid

Double solenoid

EA10□A5-25

EA10□A6-25

116

Normally closed (NC)

Normally open (NO)

EB10□A1-25  
EB10□A3-25

EB10□A2-25  
EB10□A4-25

128

**F type manifold (direct piping type)**

Manifold for combination mounting of 2, 3, 5-port valves

EAM□F

118

Manifold for 2, 3-port valves

EBM□F

129

**A, AJ type manifolds (base piping type)**

Manifold for combination mounting of 2, 3, 5-port valves

EAM□A

EAM□AJ

118

Manifold for 2, 3-port valves

EBM□A

EBM□AJ

129

**Function-specific solenoids (for both EA and EB series)**

- Standard, low current and quick response types can be identified by the color of their housings.

Standard type: Blue

Low current type: Light blue

Quick response type: White





## Solenoid

### Internal circuit

#### ●DC12V, DC24V

(Standard type)

Solenoid with LED indicator and surge suppression

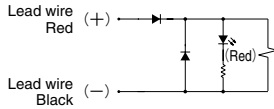

#### ●DC24V

(Low current, quick response types)

Solenoid with LED indicator and surge suppression

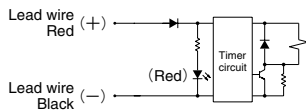

- Cautions:**
1. Do not apply megger between the pins.
  2. Leakage current inside the circuit could result in failure of the solenoid valve to return to the rest position or other erratic operation. Always use it at less than the allowable leakage current shown in the solenoid specifications on p.109 and 121. If circuit conditions, etc. cause the leakage current to exceed the maximum allowable leakage current, consult us.
  3. For the double solenoid configuration, avoid energizing both solenoids simultaneously.
  4. The standard housing type is colored blue, while the low current type is light blue, and the quick response type is white.
  5. The low current and quick response types will not activate when the power supply voltage is raised too slowly. Always apply the appropriate voltage.

### Operating principles of low current and quick response types

The low current and quick response types use a timer circuit, as shown above, that achieves power savings by switching to the holding operations mode after a certain period of time and operates at about 1/3 of the starting power consumption.

#### ●Power waveform for low current type

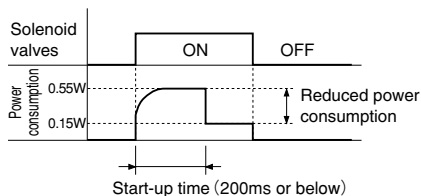

#### ●Power waveform for quick response type

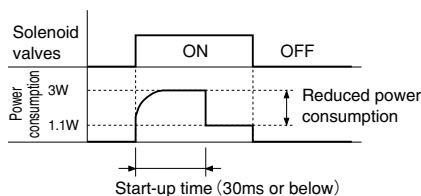

## Plug connector

### Attaching and removing plug connector

Use fingers to insert the connector into the pin, push it in until the lever claw latches onto the protruded section of the connector housing, and complete the connection.

To remove the connector, squeeze the lever along with the connector, lift the lever claw up from the protruded section of the connector housing, and pull it out.

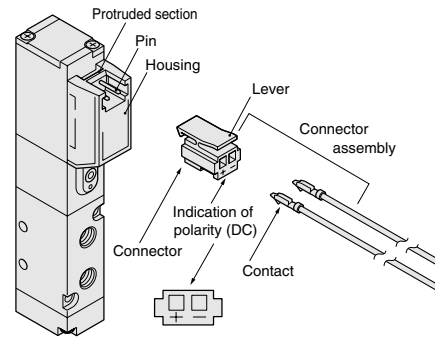

### Crimping of connecting lead wire and contact

To crimp lead wires into contacts, strip off 4mm [0.16in.] of the insulation from the end of the lead wire, insert it into the contact, and crimp it. Be sure at this time to avoid catching the insulation on the exposed wire crimping section.

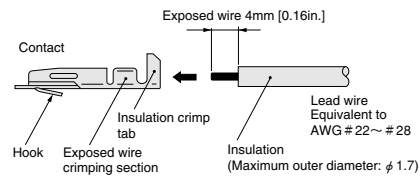

- Cautions:**
1. Do not pull hard on the lead wire.
  2. Always use a dedicated tool for crimping of connecting lead wire and contact.
- Contact: Model 702062-2M  
 Manufactured by Sumiko Tech, Inc.  
 Crimping tool: Model F1-702062  
 Manufactured by Sumiko Tech, Inc.

### Attaching and removing contact and connector

Insert the contact with lead wire into a plug connector hole until the contact hook latches on and is secured to the plug connector. Confirm that the lead wire cannot be easily pulled out.

To remove it, insert a tool with a fine tip (such as a small screwdriver) into the rectangular hole on the side of the plug connector to push up on the hook, and then pull out the lead wire.

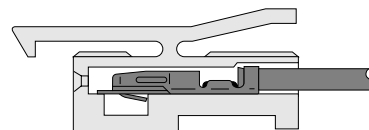

- Cautions:**
1. Do not pull hard on the lead wire. It could result in defective contacts, breaking wires, etc.
  2. If the pin is bent, use a small screwdriver, etc. to gently straighten out the pin, and then complete the connection to the plug connector.



## Manual override

### Non-locking type

To operate the manual override, press it all the way down. For the single solenoid, the valve works the same as when in the energized state as long as the manual override is pushed down, and returns to the rest position upon release. For the double solenoid, pressing the manual override on the 14 (SA) side switches the 14 (SA) to the energized state, and the unit remains in that state even after the manual override is released. To return it to the rest position, operate the manual override on the 12 (SB) side. This is the same for the solenoid 12 (SB).

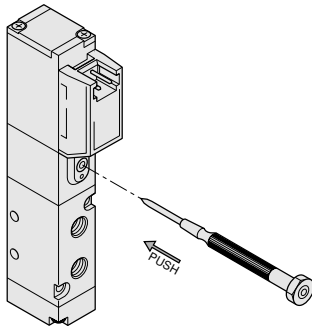

### Locking type

To lock the manual override, use a small screwdriver to push down on the manual override all the way down and turn it clockwise 45 degrees. When locked, turning the manual override 45 degrees in the counterclockwise direction returns it to its original position, and releases the lock. (Excluding the quick response type)

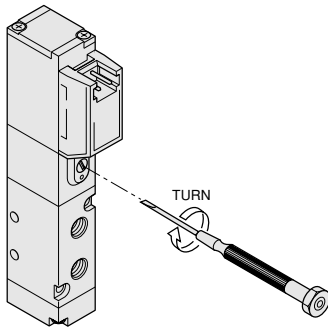

- Cautions:**
1. The EA, EB series valves are pilot type solenoid valves. As a result, the manual override cannot switch the main valve without air supplied from the 1(P) port.
  2. Always release the lock of the locking type manual override before commencing normal operation.
  3. Do not attempt to operate the manual override with a pin or other object having an extremely fine tip. It could result in damage to the manual override.

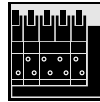

## Manifold

### Mounting valves on manifold

When mounting valves on manifold, the recommended tightening torque for the valve mounting screw is 14.7N·cm {1.5kgf·cm} [1.3lbf·in.].

### Tube

#### 1. Attaching and removing tubes

For tube connection, insert an appropriate size tube until it makes contact with the tube stopper, and lightly pull it to check the connection.

For tube removal, push the tube against the tube stopper, then push the release ring and at the same time pull the tube out.

#### 2. Either a nylon or urethane tube can be used.

Use tubes with an outer diameter tolerance within  $\pm 0.1\text{mm}$  [0.004in.] of the nominal diameter, and ensure the ovalness (difference between the large diameter and small diameter) is 0.2mm [0.008in.] or less.

(Using a Koganei tube is recommended.)

- Cautions:**
1. Do not use extra-soft tubes since their pull-out strength is significantly reduced.
  2. Only use tubes without scratches on their outer surfaces. If a scratch occurs during repeated use, cut off the scratched section.
  3. Do not bend the tube excessively near the fittings. The minimum bending radius is as shown in the table below.
  4. When attaching or removing tubes, always stop the air supply. In addition, always confirm that air has been completely exhausted from the manifold.

Tube size	Minimum bending radius	
	Nylon tube	Urethane tube
$\phi 3$	—	7 [0.28]
$\phi 4$	20 [0.79]	10 [0.39]
$\phi 6$	30 [1.18]	15 [0.59]
$\phi 8$	50 [1.97]	20 [0.79]



# Solenoid Valves EA Series

SOLENOID VALVES EA, EB SERIES

# EA

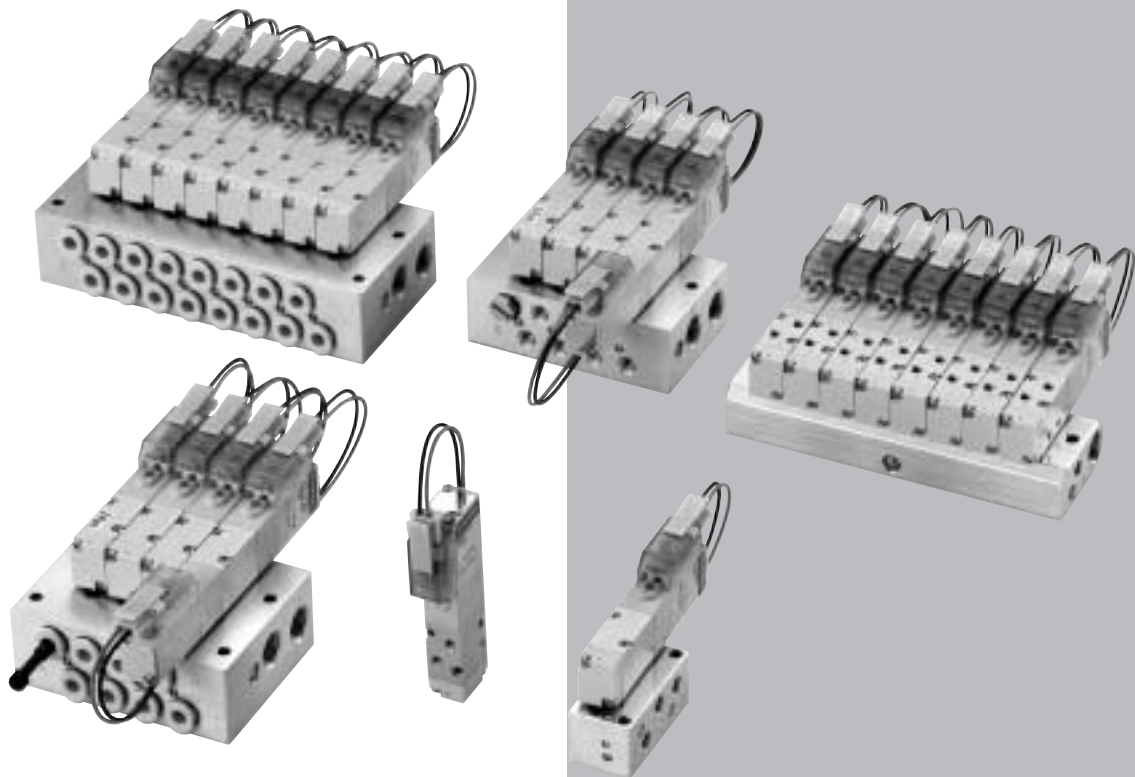

# EA SERIES SPECIFICATIONS

## Specifications

### Basic Models and Functions

Basic model	For direct piping, F type manifold	EA10□F1 <sup>Note</sup> EA10□F2 <sup>Note</sup> EA10□F3 <sup>Note</sup> EA10□F4 <sup>Note</sup>	EA10□F5	EA10□F6
	For base piping, A, AJ type manifolds	EA10□A1 <sup>Note</sup> EA10□A2 <sup>Note</sup> EA10□A3 <sup>Note</sup> EA10□A4 <sup>Note</sup>	EA10□A5	EA10□A6
Item				
Number of positions		2 positions		
Number of ports		2, 3 ports	5 ports	
Valve function		Single solenoid NC, NO	Single solenoid	Double solenoid

Remark: For the optional specifications and order codes, see p.113

Note: Valves with valve specifications F1, F2, F3, F4, A1, A2, A3, and A4 are for mounting on manifolds only, and cannot be used as single valve units.

### Specifications

Basic model	For direct piping, F type manifold	EA10□F1 EA10□F2 EA10□F3 EA10□F4	EA10□F5	EA10□F6
	For base piping, A, AJ type manifolds	EA10□A1 EA10□A2 EA10□A3 EA10□A4	EA10□A5	EA10□A6
Item				
Media		Air		
Operation type		Internal pilot type		
Flow rate characteristics <sup>Note 1</sup>	Sonic conductance C [dm <sup>3</sup> /(s·bar)]	Base piping (A, AJ type): 0.26		
	Effective area S [Cv] mm <sup>2</sup>	Direct piping (F type): 1.3 [0.07]		
Port size <sup>Note 2</sup>		M3×0.5		
Lubrication		Not required		
Operating pressure range MPa [kgf/cm <sup>2</sup> ] [psi.]		0.2~0.7 [2~7.1] [29~102]		
Proof pressure MPa[kgf/cm <sup>2</sup> ] [psi.]		1.05 [10.7] [152]		
Response time <sup>Note 3</sup> ON/OFF ms	Standard type	10/20 or below	12 or below	
	Low current type (L)	10/50 or below	12 or below	
	Quick response type (S)	6/7 or below	6 or below	
Maximum operating frequency Hz	Standard type	5		
	Low current type (L)	2		
	Quick response type (S)	10		
Minimum time to energize for self holding <sup>Note 4</sup> ms		—	50	
Operating temperature range (atmosphere and media) °C [°F]		5~50 [41~122]		
Shock resistance m/s <sup>2</sup> [G]		1373.0 {140} (Axial direction 294.2 {30})	1373.0 {140} (Axial direction 147.1 {15})	
Mounting direction		Any		

Notes: 1. For details, see the flow rate characteristics on p.110.

2. For details, see the port size on p.110.

3. Values when air pressure is 0.5MPa [73psi.].

4. For double solenoid valves.

### Solenoid Specifications

Item	Rated voltage	DC12V	DC24V	DC24V	DC24V	
		(Standard type)	(Standard type)	(Low current type)	(Quick response type)	
Operating voltage range	V	10.8~13.2 (12±10%)	21.6~26.4 (24±10%)	21.6~26.4 (24±10%)	21.6~26.4 (24±10%)	
Standard type	Current (when rated voltage is applied) mA (r.m.s)	46	23	—	—	
	Power consumption W	0.55	0.55	—	—	
Low current type Quick response type	Current (when rated voltage is applied)	Starting mA	—	23	125	
		Holding mA	—	—	6.3	46
	Power consumption	Starting W	—	—	0.55	3
		Holding W	—	—	0.15	1.1
	Start-up time (standard time) ms	—	—	200 or below	30 or below	
	Allowable leakage current mA	2	1	0.5	4	
Insulation resistance MΩ	Over 100 (value at DC500V megger)					
Color of LED indicator	Red					
Surge suppression (as standard)	Flywheel diode					



## Port Size

Specification	Port	2(B), 4(A)	1(P)	3, 5(R)	PR
Single unit	Direct piping	M3×0.5	M3×0.5	M3×0.5	—
	Base piping (with sub-base)	M5×0.8	M5×0.8	M5×0.8	M5×0.8
Manifold	F type	M3×0.5	M5×0.8	Rc1/8	Collected at 3, 5 (R) port
	A type	M5×0.8	Rc1/8	Rc1/8	
	AJ type	Quick fitting for $\phi 4$	Rc1/8	Rc1/8	

## Flow Rate Characteristics

The test method for flow rate characteristics conforms to JIS B 8390:2000 (test method for pneumatic equipment — equipment for compressible fluids — flow rate characteristics).

### ● When used as a single unit

Basic model		Flow path	Sonic conductance C dm <sup>3</sup> /(s·bar)	Critical pressure ratio b	Effective area S [Cv] mm <sup>2</sup>	
Direct piping	EA10□F5 EA10□F6	1 (P) → 4 (A)	—	—	1.30 [0.072]	0.75 [0.042] <sup>Note1</sup> (with fittings)
		1 (P) → 2 (B)	—	—		
		4 (A) → 5 (R1)	—	—		
		2 (B) → 3 (R2)	—	—		
Base piping (with sub-base)	EA10□A5 EA10□A6	1 (P) → 4 (A)	0.26	0.17	1.30 [0.072] <sup>Note3</sup>	
		1 (P) → 2 (B)	0.22	0.00	1.10 [0.061] <sup>Note3</sup>	
		4 (A) → 5 (R1)	0.26	0.17	1.30 [0.072] <sup>Note3</sup>	
		2 (B) → 3 (R2)	0.26	0.12	1.30 [0.072] <sup>Note3</sup>	

### ● When mounted on a manifold

Basic model		Flow path	Sonic conductance C dm <sup>3</sup> /(s·bar)	Critical pressure ratio b	Effective area S [Cv] mm <sup>2</sup>	
F type manifold (direct piping type)	EA10□F1 EA10□F2 EA10□F3 EA10□F4 EA10□F5 EA10□F6	1 (P) → 4 (A)	—	—	1.30 [0.072]	0.80 [0.044] <sup>Note2</sup> (with fittings)
		1 (P) → 2 (B)	—	—		
		4 (A) → 5 (R1)	—	—		
		2 (B) → 3 (R2)	—	—		
			—	—		
A, AJ type manifolds (base piping type)	EA10□A1 EA10□A2 EA10□A3 EA10□A4 EA10□A5 EA10□A6	1 (P) → 4 (A)	0.26	0.12	1.30 [0.072] <sup>Note3</sup>	
		1 (P) → 2 (B)	0.26	0.18	1.30 [0.072] <sup>Note3</sup>	
		4 (A) → 5 (R1)	0.25	0.26	1.25 [0.069] <sup>Note3</sup>	
		2 (B) → 3 (R2)	0.26	0.20	1.30 [0.072] <sup>Note3</sup>	
			—	—	—	

- Notes: 1. Quick fitting TS3-M3Ms have been mounted on connection ports 1(P), 2(B), and 4(A).  
 2. Quick fitting TS3-M3Ms have been mounted on connection ports 2(B), and 4(A).  
 3. Figures in effective area S are calculated based on sonic conductance C ( $S=5.0 \times C$ ).

**Base piping type**  
(Effective area S = 1.3mm<sup>2</sup> [Cv: 0.072])

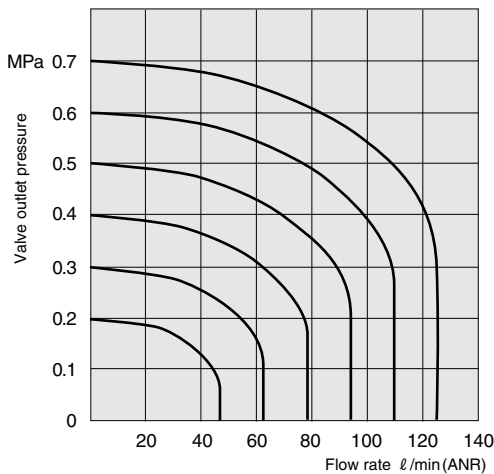

**Direct piping type with fittings**  
(Effective area S = 0.75mm<sup>2</sup> [Cv: 0.042])

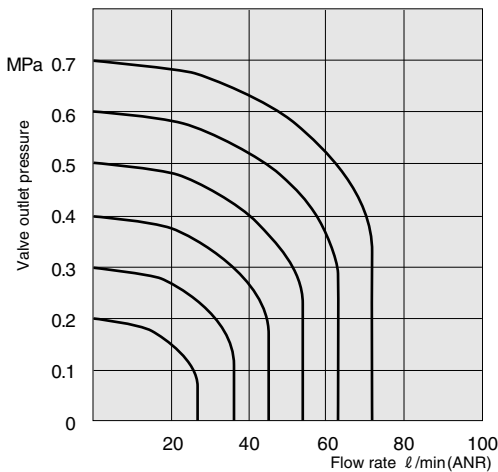

- Graphs use flow rate calculations based on the discharge method.
- Use the flow rate as a guide.

1MPa = 145psi., 1 l/min = 0.0353ft.<sup>3</sup>/min.

## Mass

### Single Valve Unit Mass

g [oz.]

Basic model	Mass	Additional mass	
		-21 (with bottom mounting base)	-25 (with sub-base)
EA10□F1	23 [0.81]	—	—
EA10□F2	23 [0.81]		
EA10□F3	23 [0.81]		
EA10□F4	23 [0.81]		
EA10□F5	23 [0.81]		
EA10□F6	38 [1.34]		
EA10□A1	23 [0.81]	—	—
EA10□A2	23 [0.81]		
EA10□A3	23 [0.81]		
EA10□A4	23 [0.81]		
EA10□A5	23 [0.81]	—	23 [0.81]
EA10□A6	38 [1.34]		

### Manifold Mass

g [oz.]

Basic model	Mass calculation of each unit (n=number of units)	Block-off plate
EAM□F	$(9 \times n) + 15$ [(0.32 × n) + 0.53]	3 [0.11]
EAM□A	$(18 \times n) + 38$ [(0.63 × n) + 1.34]	4 [0.14]
EAM□AJ	$(27.5 \times n) + 50$ [(0.97 × n) + 1.76]	4 [0.14]

Calculation example: **EAM8AJ**

**stn.1~8 EA10A5-PS-D4**

$$(27.5 \times 8) + 50 + (23 \times 8) = 454\text{g [16.01oz.]}$$

**5-port, 2-position**

**Single solenoid**

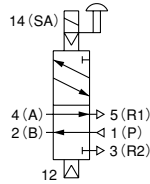

**Double solenoid**

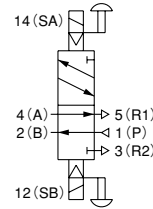

**EA10F5**  
De-energized

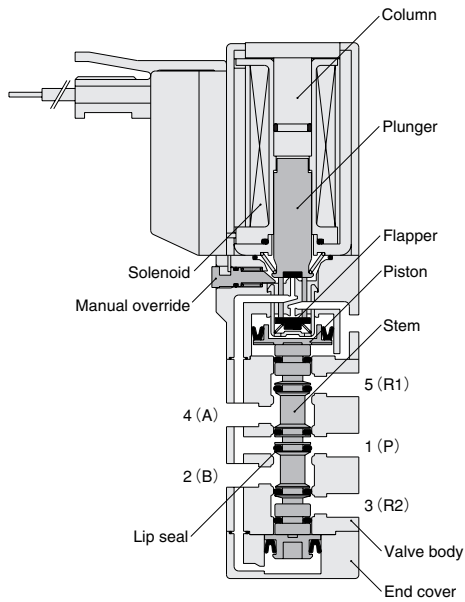

**EA10F6**  
De-energized condition after energizing solenoid 12(SB)

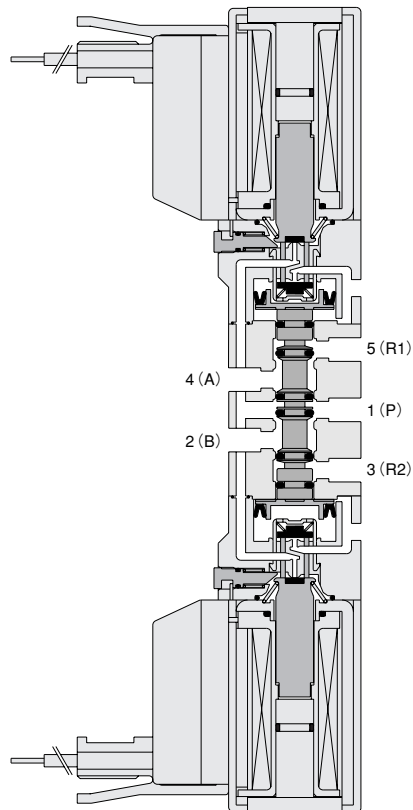

**Major Parts and Materials**

	Parts	Materials
Valve	Body	Aluminum alloy
	Stem	(anodized)
	Lip seal	Synthetic rubber
	Flapper	
	Mounting base	Mild steel (zinc plated)
	Sub-base	Aluminum alloy (anodized)
	Plunger	Magnetic stainless steel
	Column	steel
	End cover	Plastic
Manifold	Body	Aluminum alloy (anodized)
	Block-off plate	Mild steel (nickel plated)
	Seal	Synthetic rubber

# EA Series Single Valve Unit Order Codes



### Model

**EA10**

Standard type

**EA10L**

Low current type

**EA10S**

Quick response type

### Valve specification

**F1, A1:** 2-port normally closed (NC)<sup>Note1</sup>

**F2, A2:** 2-port normally open (NO)<sup>Note1</sup>

**F3, A3:** 3-port normally closed (NC)<sup>Note1</sup>

**F4, A4:** 3-port normally open (NO)<sup>Note1</sup>

**F5, A5:** 5-port 2-position, single solenoid

**F6, A6:** 5-port 2-position, double solenoid

### Mounting base

Without mounting base

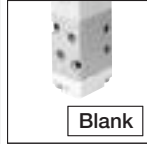

With mounting base

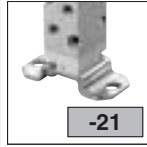

### Sub-base

Without sub-base

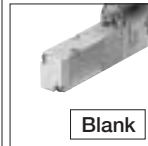

With sub-base

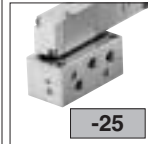

### Muffler

Without muffler

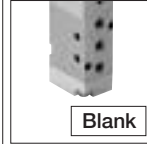

With muffler for direct piping<sup>Note2</sup>

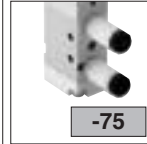

With muffler for sub-base piping<sup>Note3</sup>

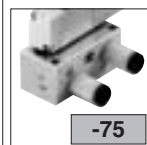

### Manual override

Non-locking type

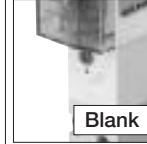

Locking type<sup>Note4</sup>

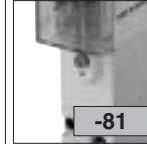

### Wiring specification

S type plug connector  
Lead wire 300mm

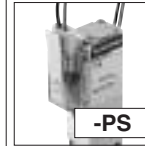

L type plug connector  
Lead wire 300mm

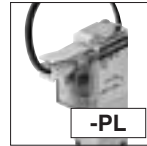

S type plug connector  
Lead wire 1000mm



L type plug connector  
Lead wire 1000mm

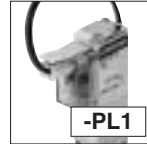

S type plug connector  
Lead wire 3000mm



L type plug connector  
Lead wire 3000mm

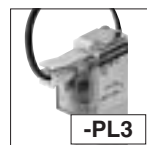

S type plug connector  
Without connector ass'y



L type plug connector  
Without connector ass'y

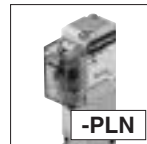

Grommet type<sup>Note5</sup>  
Lead wire 300mm  
(moisture proof specification)

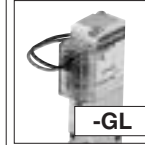

### Voltage

**-D4**

DC24V

**-D5**

DC12V<sup>Note6</sup>

300mm = 11.8in.  
1000mm = 39in.  
3000mm = 118in.

	Model	Valve specification	Mounting base	Sub-base	Muffler	Manual override	Wiring specification	Voltage
--	-------	---------------------	---------------	----------	---------	-----------------	----------------------	---------

Direct piping	EA10 EA10L EA10S	F1 <sup>Note1</sup> F2 <sup>Note1</sup> F3 <sup>Note1</sup> F4 <sup>Note1</sup>	Blank -21		Blank -75 <sup>Note2</sup>	Blank -81 <sup>Note4</sup>	-PS -PS1 -PS3 -PSN -PL -PL1 -PL3 -PLN -GL <sup>Note5</sup>	-D4 -D5 <sup>Note6</sup>
		F5						
		F6						
Base piping	EA10 EA10L EA10S	A1 <sup>Note1</sup> A2 <sup>Note1</sup> A3 <sup>Note1</sup> A4 <sup>Note1</sup>	Blank -25	Blank -75 <sup>Note3</sup>	Blank -81 <sup>Note4</sup>		-PS -PS1 -PS3 -PSN -PL -PL1 -PL3 -PLN -GL <sup>Note5</sup>	-D4 -D5 <sup>Note6</sup>
		A5 A6						

Notes: 1. Valves with valve specifications F1, F2, F3, F4, A1, A2, A3, and A4 are for mounting on manifolds only, and cannot be used as single valve units.

2. The muffler thread for direct piping is M3X0.5 and the muffler cannot be used for sub-base piping.

3. When ordering the sub-base piping with muffler, always enter both -25 (sub-base) and -75 (muffler). The muffler thread for sub-base piping is M5X0.8 and the muffler cannot be used for direct piping.

4. The locking-type manual override is not available in the quick response type EA10S.

5. The grommet type is not available in the low current type EA10L and quick response type EA10S.

6. The DC12V specification is not available in the low current type EA10L and quick response type EA10S.

# EA Series Manifold Order Codes

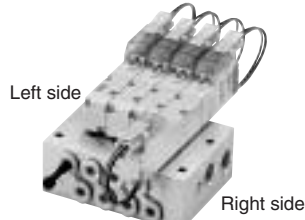
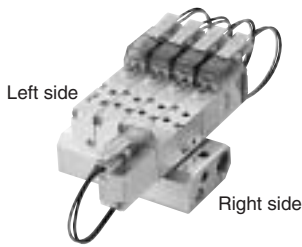

### Manifold specification

F type (direct piping type)

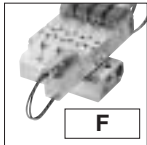

A type (base piping type)

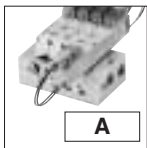

AJ type (with quick fittings)  
(base piping type)

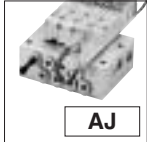

### Model

**EA10**

Standard type

**EA10L**

Low current type

**EA10S**

Quick response type

### Valve specification

**F1, A1:** 2-port normally closed (NC)

**F2, A2:** 2-port normally open (NO)

**F3, A3:** 3-port normally closed (NC)

**F4, A4:** 3-port normally open (NO)

**F5, A5:** 5-port 2-position, single solenoid

**F6, A6:** 5-port 2-position, double solenoid

### Manual override

Non-locking type

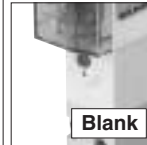

Locking type<sup>Note2</sup>

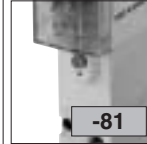

### Wiring specification

S type plug connector

Lead wire 300mm

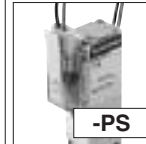

L type plug connector

Lead wire 300mm

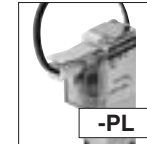

S type plug connector

Lead wire 1000mm

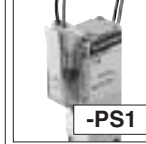

L type plug connector

Lead wire 1000mm



S type plug connector

Lead wire 3000mm



L type plug connector

Lead wire 3000mm



S type plug connector  
Without connector ass'y



L type plug connector  
Without connector ass'y



Grommet type<sup>Note3</sup>

Lead wire 300mm

(moisture proof specification)

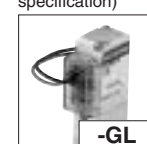

300mm = 11.8in.  
1000mm = 39in.  
3000mm = 118in.

### Voltage

**-D4**

DC24V

**-D5**

DC12V<sup>Note4</sup>

Model	Number of units	Manifold Specification	Station	Model	Valve specification	Manual override	Wiring specification	Voltage
Manifold model			Mounting valve model					

F type manifold (direct piping type)	EA10 EA10L EA10S	2 . . . 20	F	stn.1 . . . stn.□ Note1	EA10 EA10L EA10S	F1 F2 F3 F4 F5 F6	Blank -81 <sup>Note2</sup>	-PS -PS1 -PS3 -PSN -PL -PL1 -PL3 -PLN -GL <sup>Note3</sup>	-D4 -D5 <sup>Note4</sup>
			EABP-F (for block-off plate)						
A, AJ type manifolds (base piping type)	EA10 EA10L EA10S	20	A AJ	stn.1 . . . stn.□ Note1	EA10 EA10L EA10S	A1 A2 A3 A4 A5 A6	Blank -81 <sup>Note2</sup>	-PS -PS1 -PS3 -PSN -PL -PL1 -PL3 -PLN -GL <sup>Note3</sup>	-D4 -D5 <sup>Note4</sup>
EABP-A (for block-off plate)									

- Notes: 1. The valve mounting location is from the left side of the manifold.  
 2. The locking-type manual override is not available in the quick response type EA10S.  
 3. The grommet type is not available in the low current type EA10L and quick response type EA10S.  
 4. The DC12V specification is not available in the low current type EA10L and quick response type EA10S.

# EA Series Additional Parts Order Codes

**Block-off plate** (block-off plate, gasket, and 2 mounting screws)

**EABP** -

**Specification**

- F : For F type manifold
- A : For A, AJ type manifolds

## Connector-related

**EAZ** -

**Connector specification**

- P : Connector, lead wire length 300mm [11.8in.]
- P1 : Connector, lead wire length 1000mm [39in.]
- P3 : Connector, lead wire length 3000mm [118in.]
- PN : Connector, without lead wire (contacts included)

## Common connector assembly

**EAZ** -

**Connector specification**

- PA : Positive common A type, connector, lead wire length 300mm [11.8in.]
- PA1 : Positive common A type, connector, lead wire length 1000mm [39in.]
- PA3 : Positive common A type, connector, lead wire length 3000mm [118in.]
- PB : Positive common B type, connector, lead wire length 300mm [11.8in.]
- PB1 : Positive common B type, connector, lead wire length 1000mm [39in.]
- PB3 : Positive common B type, connector, lead wire length 3000mm [118in.]
- PC : Positive common C type, connector, lead wire length 300mm [11.8in.]
- PC1 : Positive common C type, connector, lead wire length 1000mm [39in.]
- PC3 : Positive common C type, connector, lead wire length 3000mm [118in.]
- CPN : Positive common, connector, without lead wire (short bar and contacts included)

**A type: EAZ-PA**\*



**B type: EAZ-PB**\*

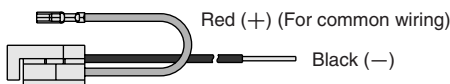

**C type: EAZ-PC**\*

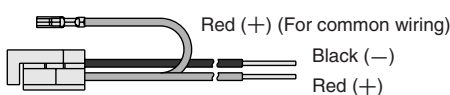

\*Lead wire length      **Blank** : 300mm [11.8in.]  
    **1** : 1000mm [39in.]  
    **3** : 3000mm [118in.]

**Application example**

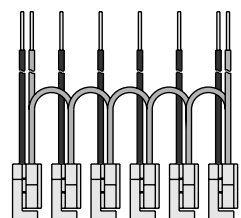

A type B type B type B type B type C type

# Dimensions of EA Series Single Valve Unit (mm)

5-port, single solenoid  
**EA10**  **F5-PL**

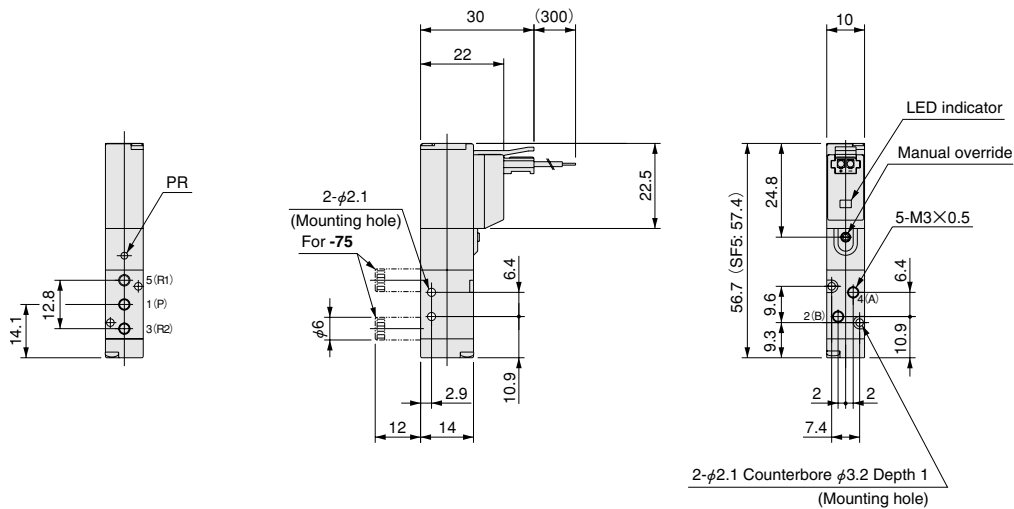

5-port, single solenoid (with sub-base)  
**EA10**  **A5-25-PL**

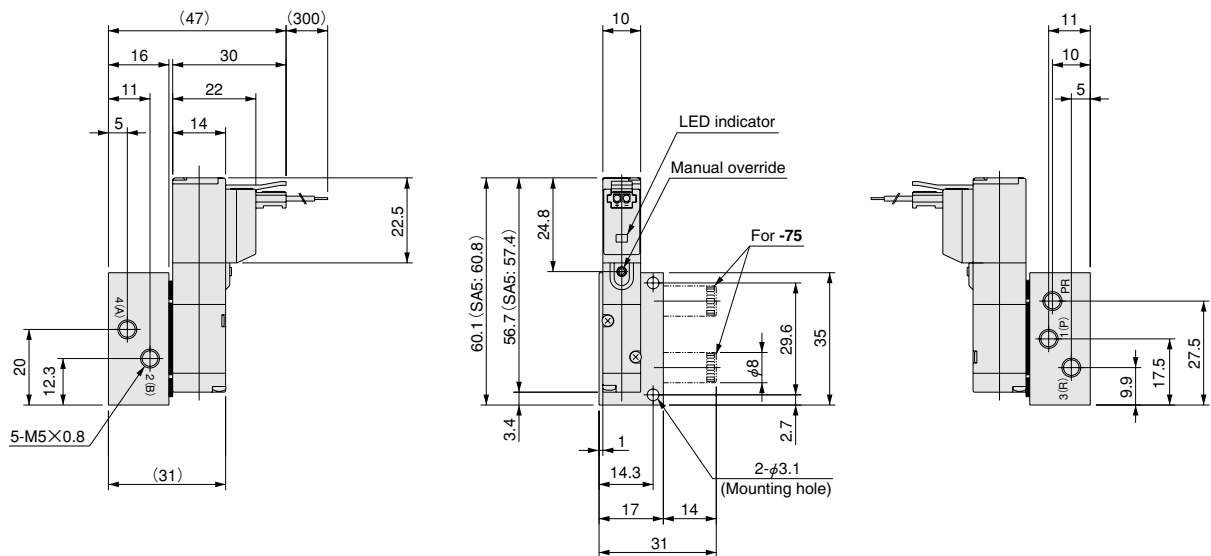

## Options

- Mounting base: **-21**
- Locking type manual override: **-81**
- Grommet: **-GL**
- S type plug connector: **-PS**

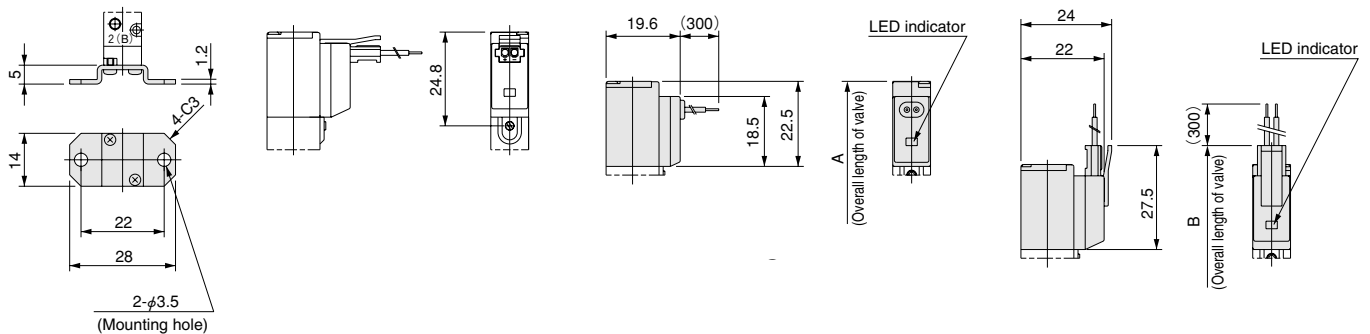

Model	Code	A	B	Remark
EA10F1~EA10F5, EA10A1~EA10A5		56.7	61.7	Overall length to the end of the valve
EA10LF1~EA10LF5, EA10LA1~EA10LA5		—	61.7	
EA10SF1~EA10SF5, EA10SA1~EA10SA5		—	62.4	

mm

# Dimensions of EA Series Single Valve Unit (mm)

## 5-port, double solenoid EA10□F6-PL

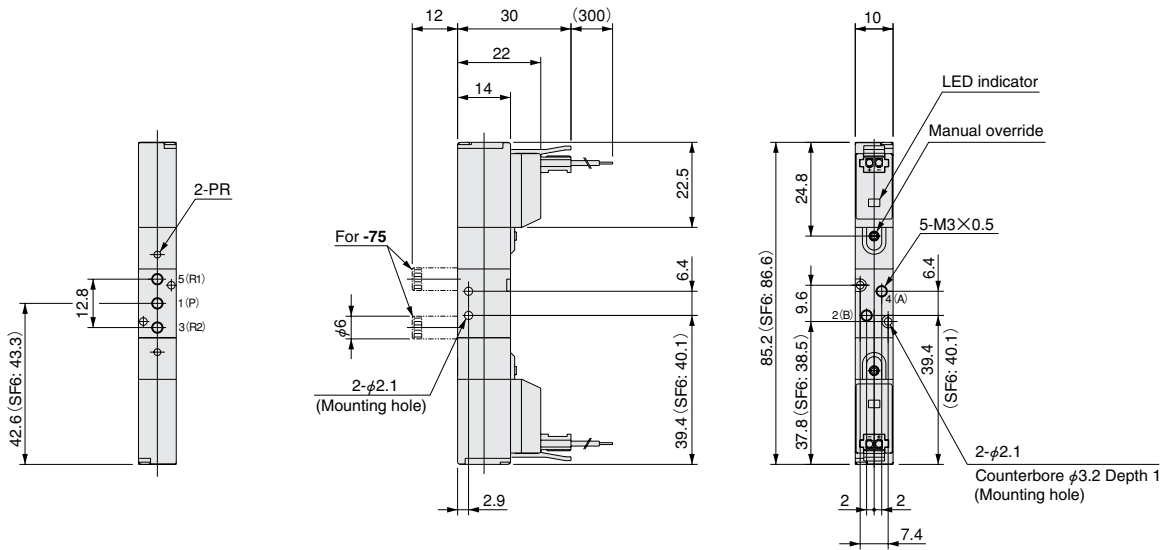

## 5-port, double solenoid (with sub-base) EA10□A6-25-PL

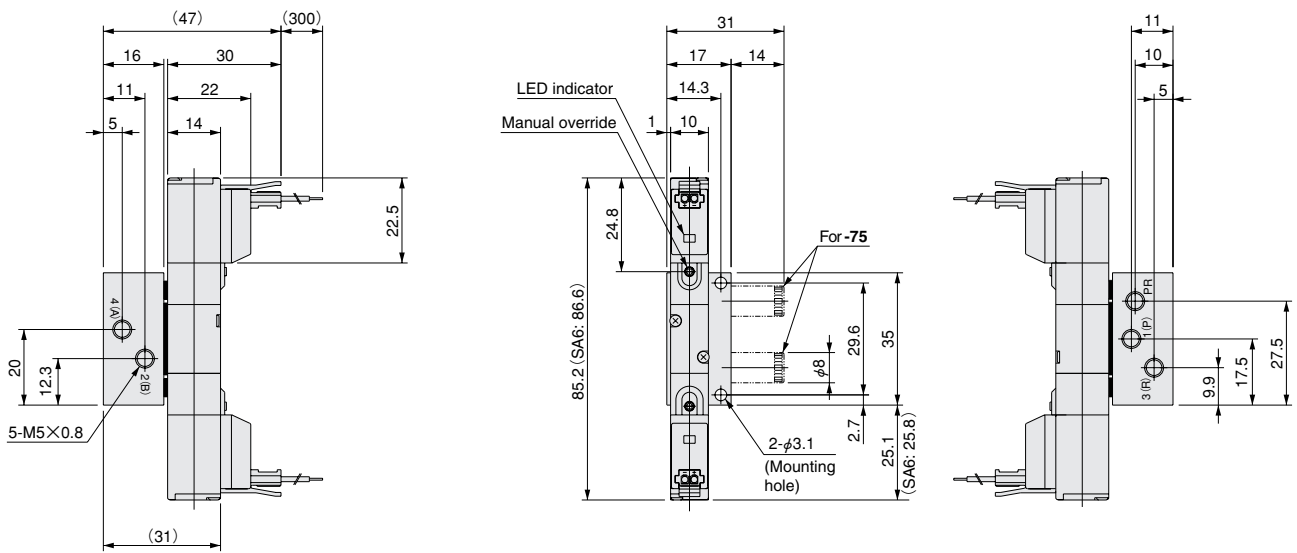

### Options

● Locking type manual override: **-81**

● Grommet: **-GL**

● S type plug connector: **-PS**

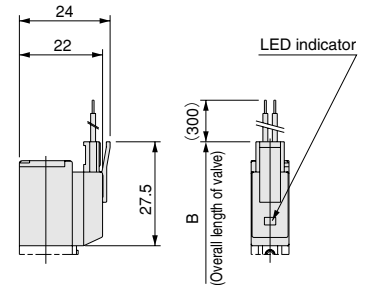
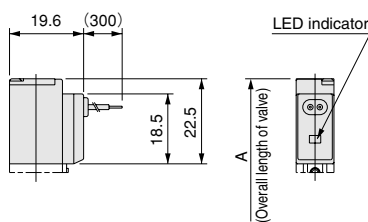
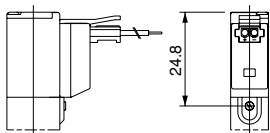

Model	Code	A	B	Remark
EA10F6, EA10A6		85.2	95.2	Overall length to the end of the solenoid on the opposite side
EA10LF6, EA10LA6		—	95.2	
EA10SF6, EA10SA6		—	96.6	



# Dimensions of EA Series Manifold (mm)

Manifold for combination mounting of 2, 3, 5-port valves

## EAM□F (Direct piping type)

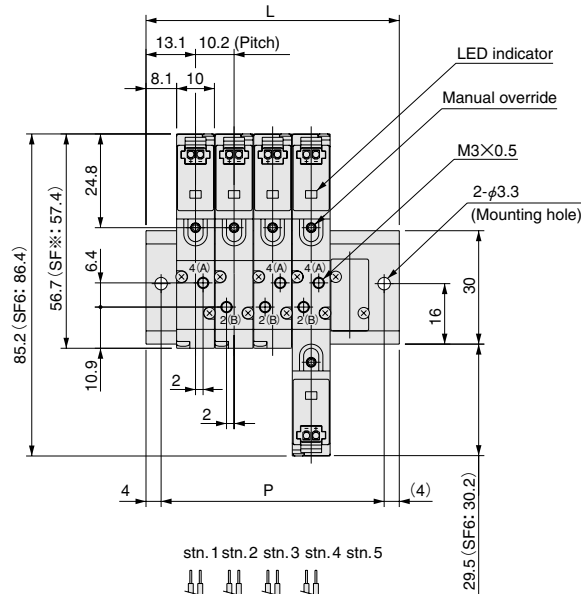
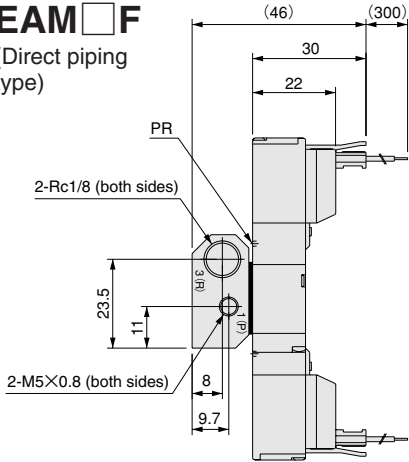

### Unit dimensions

Number of units	L	P
2	36.4	28.4
3	46.6	38.6
4	56.8	48.8
5	67.0	59.0
6	77.2	69.2
7	87.4	79.4
8	97.6	89.6
9	107.8	99.8
10	118.0	110.0
11	128.2	120.2
12	138.4	130.4
13	148.6	140.6
14	158.8	150.8
15	169.0	161.0
16	179.2	171.2
17	189.4	181.4
18	199.6	191.6
19	209.8	201.8
20	220.0	212.0

[Installation example]

### EAM5F

- stn.1 EA10F3-PL-D4
- stn.2 EA10F4-PL-D4
- stn.3 EA10F5-PL-D4
- stn.4 EA10F6-PL-D4
- stn.5 EABP-F

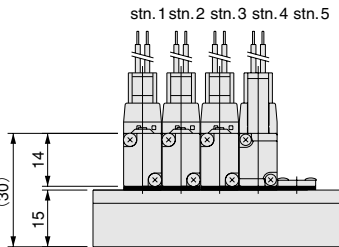

## EAM□A (Base piping type)

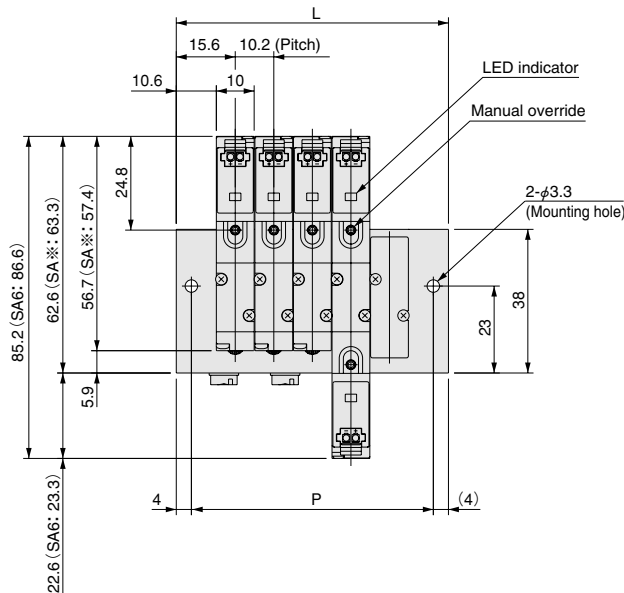
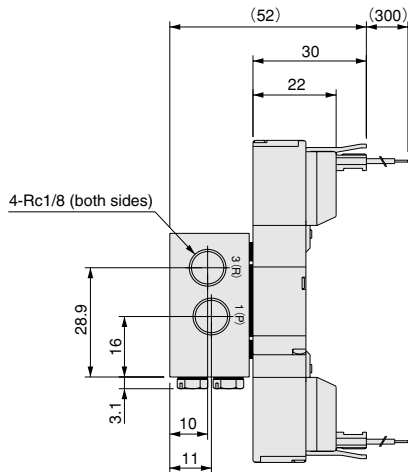

### Unit dimensions

Number of units	L	P
2	41.4	33.4
3	51.6	43.6
4	61.8	53.8
5	72.0	64.0
6	82.2	74.2
7	92.4	84.4
8	102.6	94.6
9	112.8	104.8
10	123.0	115.0
11	133.2	125.2
12	143.4	135.4
13	153.6	145.6
14	163.8	155.8
15	174.0	166.0
16	184.2	176.2
17	194.4	186.4
18	204.6	196.6
19	214.8	206.8
20	225.0	217.0

[Installation example]

### EAM5A

- stn.1 EA10A3-PL-D4
- stn.2 EA10A4-PL-D4
- stn.3 EA10A5-PL-D4
- stn.4 EA10A6-PL-D4
- stn.5 EABP-A

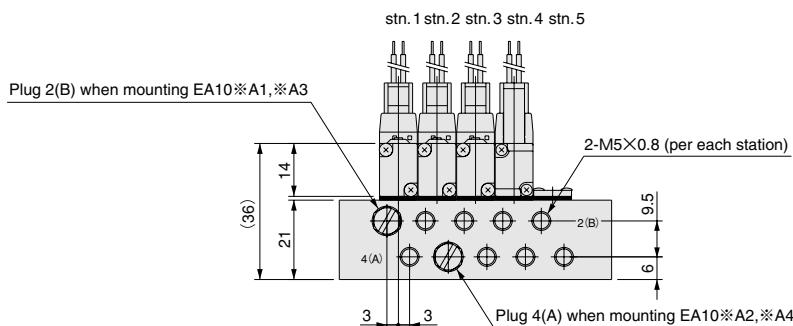

# Dimensions of EA Series Manifold (mm)

Manifold for combination mounting of 2, 3, 5-port valves

## EAM□AJ

(Base piping type with quick fittings)

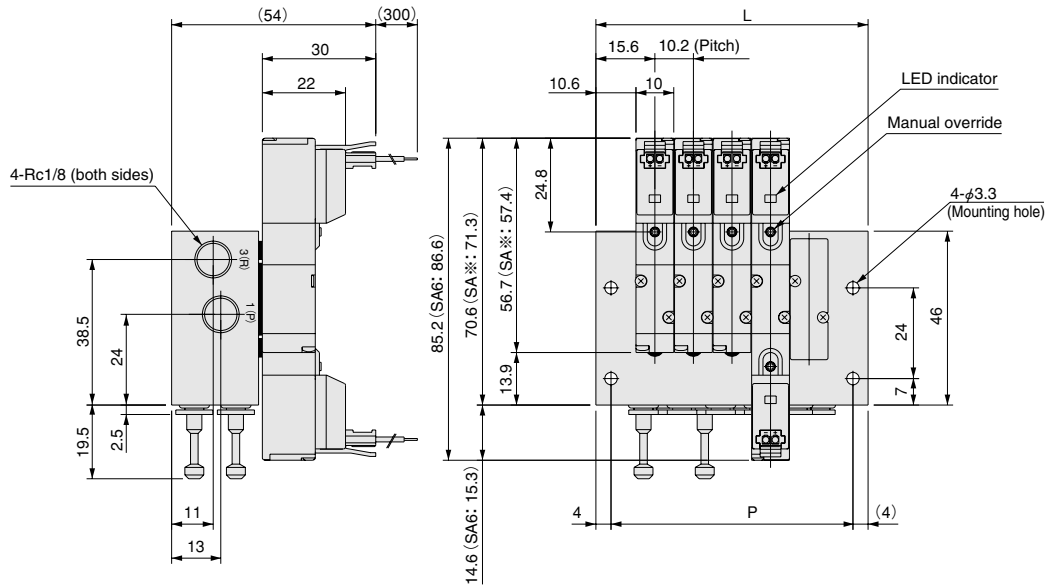

### Unit dimensions

Number of units	L	P
2	41.4	33.4
3	51.6	43.6
4	61.8	53.8
5	72.0	64.0
6	82.2	74.2
7	92.4	84.4
8	102.6	94.6
9	112.8	104.8
10	123.0	115.0
11	133.2	125.2
12	143.4	135.4
13	153.6	145.6
14	163.8	155.8
15	174.0	166.0
16	184.2	176.2
17	194.4	186.4
18	204.6	196.6
19	214.8	206.8
20	225.0	217.0

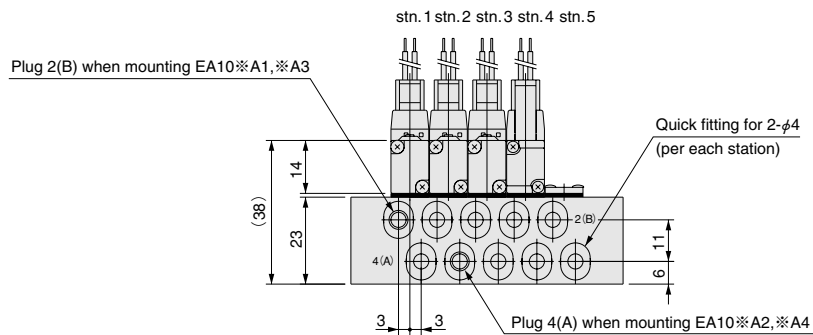

[Installation example]

### EAM5AJ

- stn. 1 EA10A3-PL-D4
- stn. 2 EA10A4-PL-D4
- stn. 3 EA10A5-PL-D4
- stn. 4 EA10A6-PL-D4
- stn. 5 EABP-A

# Solenoid Valves EB Series

SOLENOID VALVES EA, EB SERIES

# EB

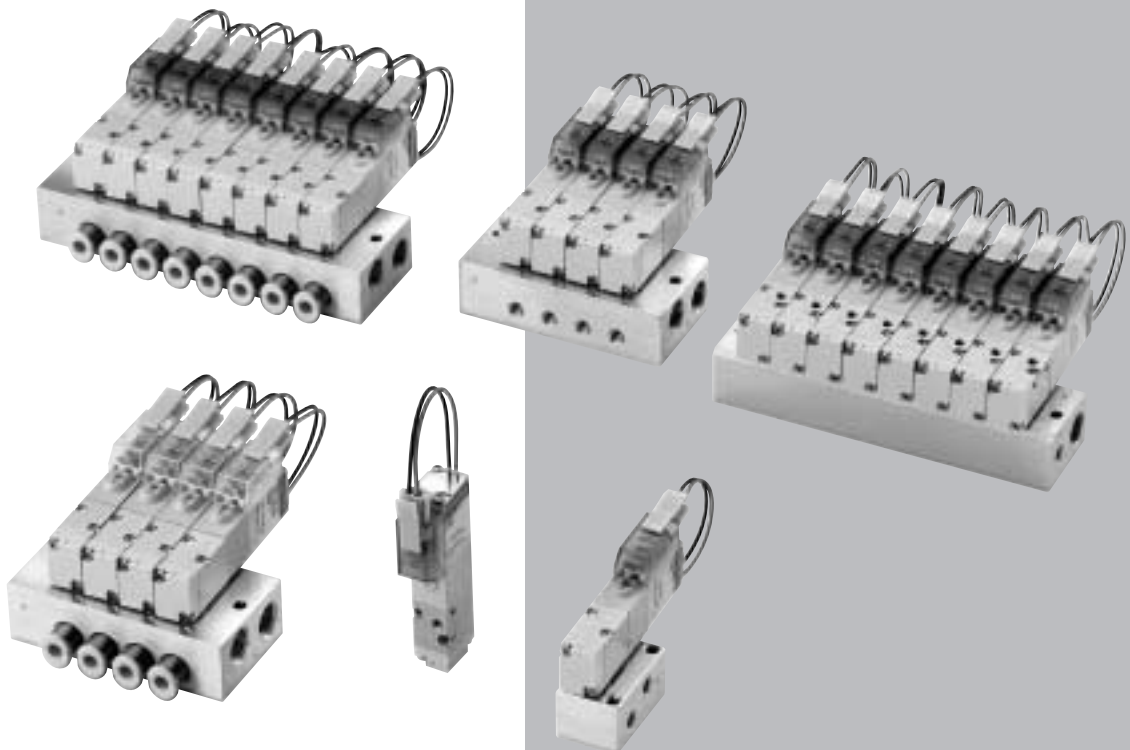

# EB SERIES SPECIFICATIONS

## Specifications

### Basic Models and Functions

Basic model	For direct piping, F type manifold	EB10□F1 EB10□F2 EB10□F3 EB10□F4
	For base piping, A, AJ type manifolds	EB10□A1 EB10□A2 EB10□A3 EB10□A4
Item		
Number of positions		2 positions
Number of ports		2, 3 ports
Valve function		Single solenoid NC, NO

Remark: For the optional specifications and order codes, see p.125.

### Specifications

Basic model	For direct piping, F type manifold	EB10□F1 EB10□F2 EB10□F3 EB10□F4
	For base piping, A, AJ type manifolds	EB10□A1 EB10□A2 EB10□A3 EB10□A4
Item		
Media		Air
Operation type		Internal pilot type
Flow rate characteristics <sup>Note 1</sup>	Sonic conductance C [dm <sup>3</sup> /(s·bar)]	Base piping (A, AJ type): 0.26
	Effective area S [Cv] mm <sup>2</sup>	Direct piping (F type): 1.3 {0.07}
Port size <sup>Note 2</sup>		M3×0.5
Lubrication		Not required
Operating pressure range	MPa {kgf/cm <sup>2</sup> } [psi.]	0.2~0.7 {2~7.1} [29~102]
Proof pressure	MPa {kgf/cm <sup>2</sup> } [psi.]	1.05 {10.7} [152]
Response time <sup>Note 3</sup> ON/OFF	Standard type	10/20 or below
	Low current type (L)	10/50 or below
	Quick response type (S)	6/7 or below
Maximum operating frequency	Standard type	5
	Low current type (L)	2
	Quick response type (S)	10
Operating temperature range (atmosphere and media)	°C [°F]	5~50 [41~122]
Shock resistance	m/s <sup>2</sup> {G}	1373.0 {140} (Axial direction 294.2 {30})
Mounting direction		Any

Notes: 1. For details, see the flow rate characteristics on p.122.

2. For details, see the port size on p.122.

3. Values when air pressure is 0.5MPa [73psi.].

### Solenoid Specifications

Item	Rated voltage	DC24V				
		DC12V (Standard type)	DC24V (Standard type)	DC24V (Low current type)	DC24V (Quick response type)	
Operating voltage range	V	10.8~13.2 (12±10%)	21.6~26.4 (24±10%)	21.6~26.4 (24±10%)	21.6~26.4 (24±10%)	
Standard type	Current (when rated voltage is applied) mA (r.m.s)	46	23	—	—	
	Power consumption W	0.55	0.55	—	—	
Low current type Quick response type	Current (when rated voltage is applied)	Starting mA	—	23	125	
		Holding mA	—	—	6.3	46
	Power consumption	Starting W	—	—	0.55	3
		Holding W	—	—	0.15	1.1
	Start-up time (standard time) ms	—	—	200 or below	30 or below	
Allowable leakage current	mA	2	1	0.5	4	
Insulation resistance	MΩ	Over 100 (value at DC500V megger)				
Color of LED indicator		Red				
Surge suppression (as standard)		Flywheel diode				

## Port Size

Specification	Port	2(A)	1(P)	3(R)	PR
Single unit	Direct piping	M3×0.5	M3×0.5	M3×0.5	—
	Base piping (with sub-base)	M5×0.8	M5×0.8	M5×0.8	M5×0.8
Manifold	F type	M3×0.5	M5×0.8	Rc1/8	Collected at 3(R) port
	A type	M5×0.8	Rc1/8	Rc1/8	
	AJ type	Quick fitting for $\phi 4$	Rc1/8	Rc1/8	

## Flow Rate Characteristics

The test method for flow rate characteristics conforms to JIS B 8390:2000 (test method for pneumatic equipment — equipment for compressible fluids — flow rate characteristics).

### ● When used as a single unit

Basic model		Flow path	Sonic conductance C dm <sup>3</sup> /(s·bar)	Critical pressure ratio b	Effective area S [Cv] mm <sup>2</sup>	
Direct piping	EB10□F1 EB10□F2	1 (P) → 2 (A)	—	—	1.30 [0.072]	0.75 [0.042] <small>Note1</small> (with fittings)
	EB10□F3 EB10□F4	2 (A) → 3 (R)	—	—		
Base piping (with sub-base)	EB10□A1 EB10□A2	1 (P) → 2 (A)	0.23	0.05	1.15 [0.064] <small>Note3</small>	
	EB10□A3 EB10□A4	2 (A) → 3 (R)	0.23	0.38	1.15 [0.064] <small>Note3</small>	

### ● When mounted on a manifold

Basic model		Flow path	Sonic conductance C dm <sup>3</sup> /(s·bar)	Critical pressure ratio b	Effective area S [Cv] mm <sup>2</sup>	
F type manifold (direct piping type)	EB10□F1 EB10□F2	1 (P) → 2 (A)	—	—	1.30 [0.072]	0.80 [0.044] <small>Note2</small> (with fitting)
	EB10□F3 EB10□F4	2 (A) → 3 (R)	—	—		
A, AJ type manifolds (base piping type)	EB10□A1 EB10□A2	1 (P) → 2 (A)	0.26	0.21	1.30 [0.072] <small>Note3</small>	
	EB10□A3 EB10□A4	2 (A) → 3 (R)	0.24	0.46	1.20 [0.067] <small>Note3</small>	

Notes: 1. Quick fitting TS3-M3Ms have been mounted on connection ports 1(P), and 2(A).

2. Quick fitting TS3-M3M has been mounted on connection port 2(A).

3. Figures in effective area S are calculated based on sonic conductance C ( $S=5.0 \times C$ )

**Base piping type**  
(Effective area S = 1.3mm<sup>2</sup> [Cv: 0.072])

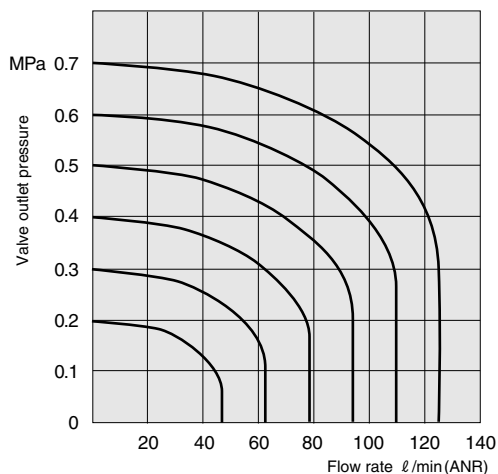

**Direct piping type with fittings**  
(Effective area S = 0.75mm<sup>2</sup> [Cv: 0.042])

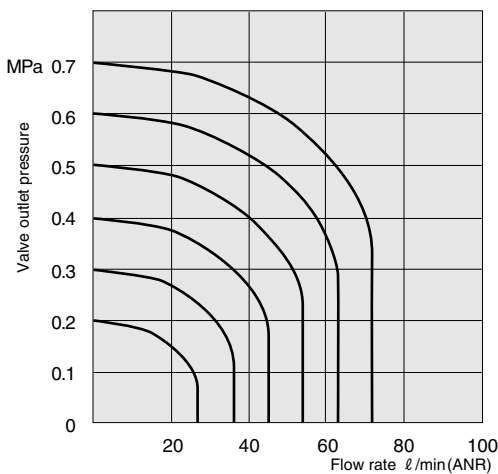

- Graphs use flow rate calculations based on the discharge method.
- Use the flow rate as a guide.

1MPa = 145psi., 1 l/min = 0.0353ft.<sup>3</sup>/min.

## Mass

### Single Valve Unit Mass

g [oz.]

Basic model	Mass	Additional mass	
		-21 (with bottom mounting base)	-25 (with sub-base)
EB10□F1	22 [0.78]	4 [0.14]	—
EB10□F2	22 [0.78]		
EB10□F3	22 [0.78]		
EB10□F4	22 [0.78]		
EB10□A1	22 [0.78]	—	17 [0.60]
EB10□A2	22 [0.78]		
EB10□A3	22 [0.78]		
EB10□A4	22 [0.78]		

### Manifold Mass

g [oz.]

Basic model	Mass calculation of each unit (n= number of units)	Block-off plate
EBM□F	$(10.5 \times n) + 15$ [(0.37 × n) + 0.53]	2 [0.07]
EBM□A	$(12.5 \times n) + 19$ [(0.44 × n) + 0.67]	3 [0.11]
EBM□AJ	$(14 \times n) + 24$ [(0.49 × n) + 0.85]	3 [0.11]

Calculation example: **EBM8AJ**

**stn.1~8 EB10A3-PS-D4**

$$(14 \times 8) + 24 + (22 \times 8) = 312\text{g [11.01oz.]}$$

**2-port**

**Normally closed (NC)**

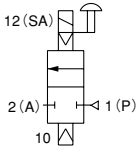

**Normally open (NO)**

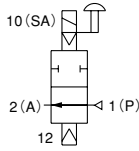

**EB10F1**  
De-energized

**EB10F2**  
De-energized

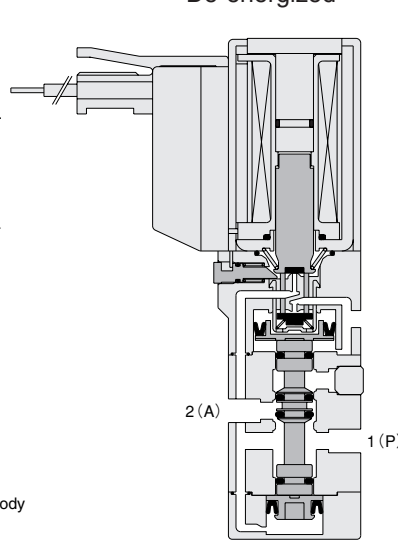
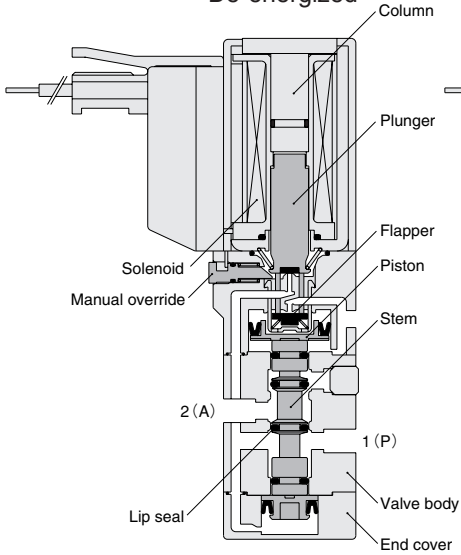

**Major Parts and Materials**

Parts	Materials
Body	Aluminum alloy
Stem	(anodized)
Lip seal	Synthetic rubber
Flapper	
Valve	
Mounting base	Mild steel (zinc plated)
Sub-base	Aluminum alloy (anodized)
Plunger	Magnetic stainless steel
Column	Steel
End cover	Plastic
Manifold	
Body	Aluminum alloy (anodized)
Block-off plate	Mild steel (nickel plated)
Seal	Synthetic rubber

**3-port**

**Normally closed (NC)**

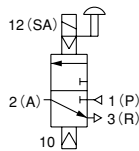

**Normally open (NO)**

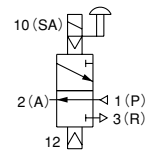

**EB10F3**  
De-energized

**EB10F4**  
De-energized

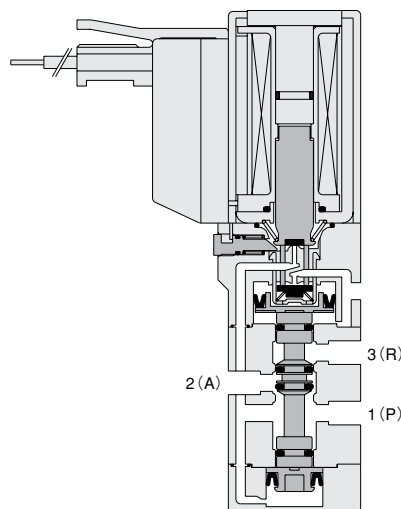
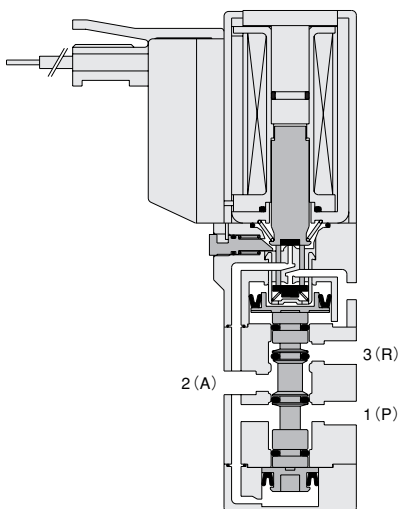

# EB Series Single Valve Unit Order Codes



## Model

**EB10**

Standard type

**EB10L**

Low current type

**EB10S**

Quick response type

## Valve specification

**F1, A1:** 2-port normally closed (NC)

**F2, A2:** 2-port normally open (NO)

**F3, A3:** 3-port normally closed (NC)

**F4, A4:** 3-port normally open (NO)

## Mounting base

Without mounting base

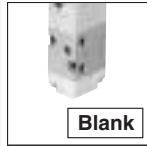

With mounting base

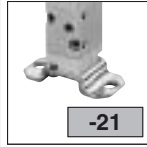

## Sub-base

Without sub-base

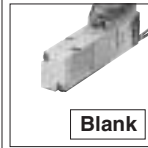

With sub-base



## Muffler

Without muffler

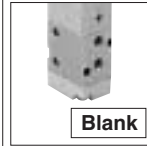

With muffler for direct piping<sup>Note1</sup>

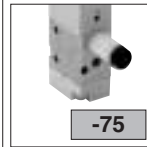

With muffler for sub-base piping<sup>Note2</sup>

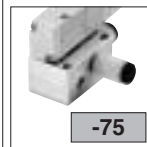

## Manual override

Non-locking type

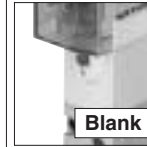

Locking type<sup>Note3</sup>



## Wiring specification

S type plug connector  
Lead wire 300mm

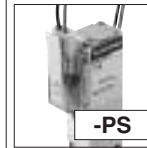

L type plug connector  
Lead wire 300mm

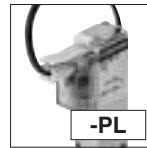

S type plug connector  
Lead wire 1000mm



L type plug connector  
Lead wire 1000mm

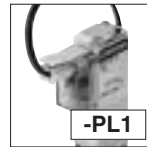

S type plug connector  
Lead wire 3000mm

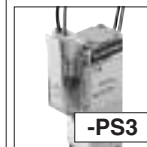

L type plug connector  
Lead wire 3000mm

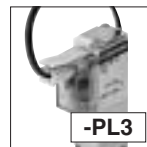

S type plug connector  
Without connector ass'y



L type plug connector  
Without connector ass'y

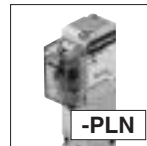

Grommet type<sup>Note4</sup>  
Lead wire 300mm  
(moisture proof specification)

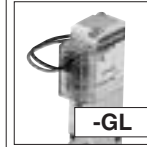

## Voltage

**-D4**

DC24V

**-D5**

DC12V<sup>Note5</sup>

300mm = 11.8in.  
1000mm = 39in.  
3000mm = 118in.

	Model	Valve specification	Mounting base	Sub-base	Muffler	Manual override	Wiring specification	Voltage
--	-------	---------------------	---------------	----------	---------	-----------------	----------------------	---------

Direct piping	EB10 EB10L EB10S	F1 F2  F3 F4	Blank -21		Blank -75 <sup>Note1</sup>	Blank -81 <sup>Note3</sup>	-PS -PS1 -PS3 -PSN -PL -PL1 -PL3 -PLN -GL <sup>Note4</sup>	-D4 -D5 <sup>Note5</sup>
Base piping	EB10 EB10L EB10S	A1 A2 A3 A4		Blank -25	Blank -75 <sup>Note2</sup>	Blank -81 <sup>Note3</sup>	-PS -PS1 -PS3 -PSN -PL -PL1 -PL3 -PLN -GL <sup>Note4</sup>	-D4 -D5 <sup>Note5</sup>

- Notes: 1. The muffler thread for direct piping is M3×0.5 and the muffler cannot be used for sub-base piping.  
2. When ordering the sub-base piping with muffler, always enter both -25 (sub-base) and -75 (muffler). The muffler thread for sub-base piping is M5×0.8 and the muffler cannot be used for direct piping.  
3. The locking-type manual override is not available in the quick response type EB10S.

4. The grommet type is not available in the low current type EB10L and quick response type EB10S.  
5. The DC12V specification is not available in the low current type EB10L and quick response type EB10S.



# EB Series Manifold Order Codes

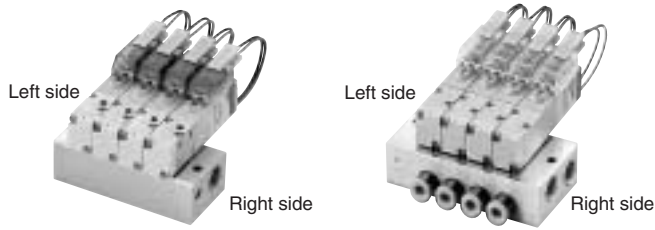

### Manifold specification

F type (direct piping type)

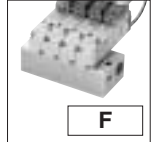

A type (base piping type)

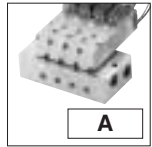

AJ type (with quick fittings)  
(base piping type)

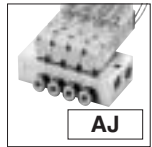

### Model

- EB10**  
Standard type
- EB10L**  
Low current type
- EB10S**  
Quick response type

### Valve specification

- F1, A1**: 2-port normally closed (NC)
- F2, A2**: 2-port normally open (NO)
- F3, A3**: 3-port normally closed (NC)
- F4, A4**: 3-port normally open (NO)

### Manual Override

Non-locking type

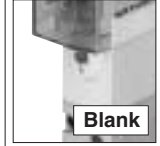

Locking type<sup>Note2</sup>



### Wiring specification

S type plug connector  
Lead wire 300mm

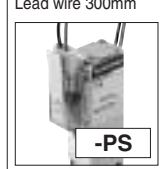

L type plug connector  
Lead wire 300mm

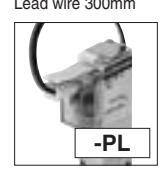

S type plug connector  
Lead wire 1000mm



L type plug connector  
Lead wire 1000mm



S type plug connector  
Lead wire 3000mm



L type plug connector  
Lead wire 3000mm



S type plug connector  
Without connector ass'y



L type plug connector  
Without connector ass'y



Grommet type<sup>Note3</sup>  
Lead wire 300mm  
(moisture proof specification)



300mm = 11.8in.  
1000mm = 39in.  
3000mm = 118in.

### Voltage

**-D4**

DC24V

**-D5**

DC12V<sup>Note4</sup>

Model	Number of units	Manifold specification	Station	Model	Valve specification	Manual override	Wiring specification	Voltage
-------	-----------------	------------------------	---------	-------	---------------------	-----------------	----------------------	---------

	Manifold model				Mounting valve model				
	Model	Number of units	Manifold specification	Station	Model	Valve specification	Manual override	Wiring specification	Voltage
F type manifold (direct piping type)	EBM	2 • • • 20	F	stn.1 • • • stn.□ <small>Note1</small>	EB10 EB10L EB10S	F1 F2 F3 F4	Blank -81 <sup>Note2</sup>	-PS -PS1 -PS3 -PSN -PL -PL1 -PL3 -PLN -GL <sup>Note3</sup>	-D4 -D5 <sup>Note4</sup>
<b>EBBP-F (for block-off plate)</b>									
A, AJ type manifolds (base piping type)			A AJ	stn.1 • • • stn.□ <small>Note1</small>	EB10 EB10L EB10S	A1 A2 A3 A4	Blank -81 <sup>Note2</sup>	-PS -PS1 -PS3 -PSN -PL -PL1 -PL3 -PLN -GL <sup>Note3</sup>	-D4 -D5 <sup>Note4</sup>
<b>EBBP-A (for block-off plate)</b>									

Notes: 1. The valve mounting location is from the left side of the manifold.  
 2. The locking-type manual override is not available in the quick response type **EB10S**.  
 3. The grommet type is not available in the low current type **EB10L** and quick response type **EB10S**.  
 4. The DC12V specification is not available in the low current type **EB10L** and quick response type **EB10S**.

SOLENOID VALVES EA, EB SERIES

# EB Series Additional Parts Order Codes

## Block-off plate (block-off plate, gasket, and 2 mounting screws)

**EBBP** -

**Specification**

- F : For F type manifold
- A : For A, AJ type manifolds

## Connector-related

**EAZ** -

**Connector specification**

- P : Connector, lead wire length 300mm [11.8in.]
- P1 : Connector, lead wire length 1000mm [39in.]
- P3 : Connector, lead wire length 3000mm [118in.]
- PN : Connector, without lead wire (contacts included)

## Common connector assembly

**EAZ** -

**Connector specification**

- PA : Positive common A type, connector, lead wire length 300mm [11.8in.]
- PA1 : Positive common A type, connector, lead wire length 1000mm [39in.]
- PA3 : Positive common A type, connector, lead wire length 3000mm [118in.]
- PB : Positive common B type, connector, lead wire length 300mm [11.8in.]
- PB1 : Positive common B type, connector, lead wire length 1000mm [39in.]
- PB3 : Positive common B type, connector, lead wire length 3000mm [118in.]
- PC : Positive common C type, connector, lead wire length 300mm [11.8in.]
- PC1 : Positive common C type, connector, lead wire length 1000mm [39in.]
- PC3 : Positive common C type, connector, lead wire length 3000mm [118in.]
- CPN : Positive common, connector, without lead wire (short bar and contacts included)

**A type: EAZ-PA**\*



**B type: EAZ-PB**\*

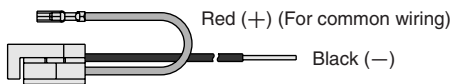

**C type: EAZ-PC**\*

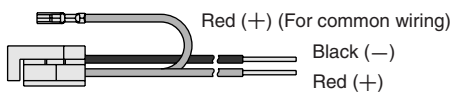

\*Lead wire length      **Blank** : 300mm [11.8in.]  
    **1** : 1000mm [39in.]  
    **3** : 3000mm [118in.]

**Application example**

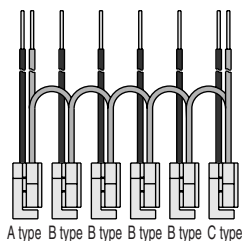

# Dimensions of EB Series Single Valve Unit (mm)

2, 3-port, single solenoid

**EB10** □ **F1-PL**

**EB10** □ **F2-PL**

**EB10** □ **F3-PL**

**EB10** □ **F4-PL**

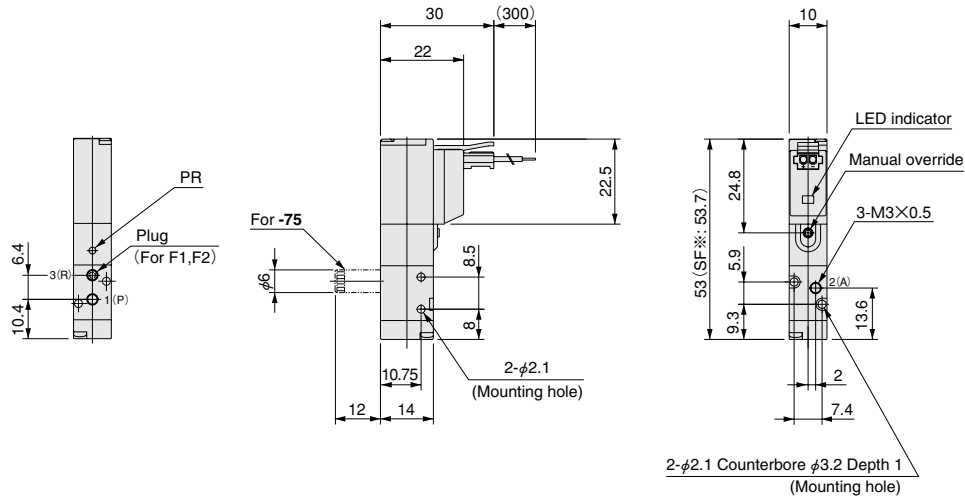

2, 3-port, single solenoid (with sub-base)

**EB10** □ **A1-25-PL**

**EB10** □ **A2-25-PL**

**EB10** □ **A3-25-PL**

**EB10** □ **A4-25-PL**

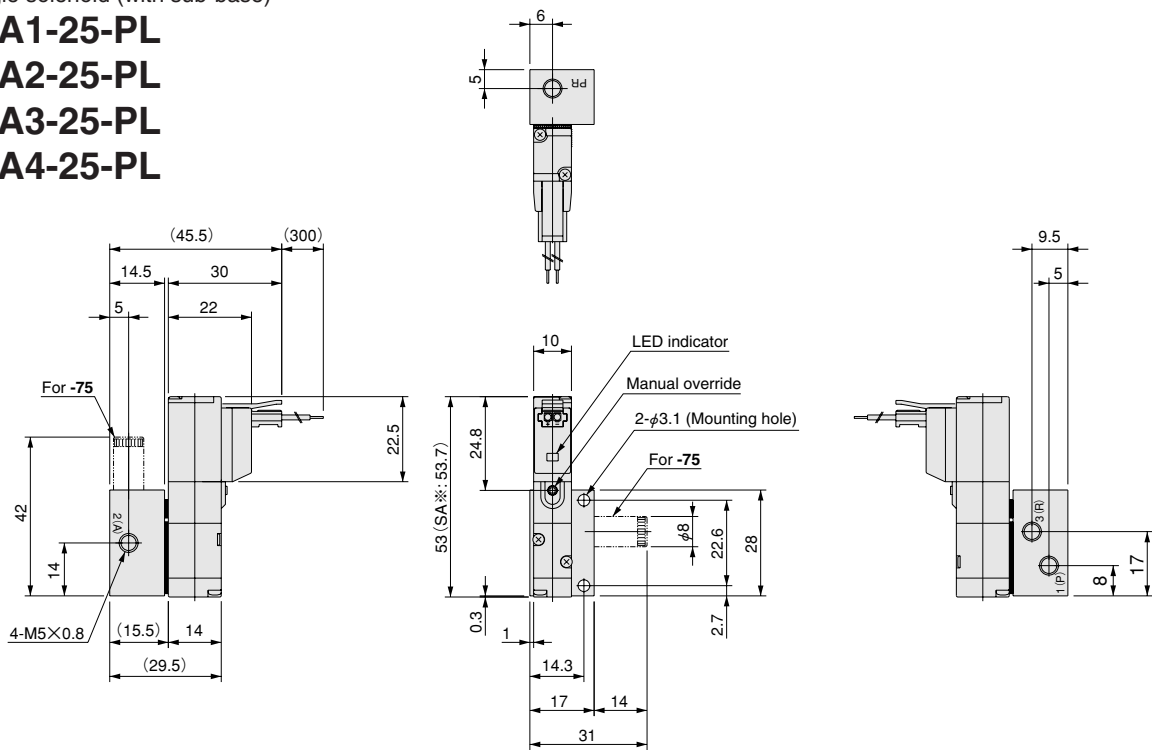

## Options

● Mounting base: **-21**

● Locking type manual override: **-81**

● Grommet: **-GL**

● S type plug connector: **-PS**

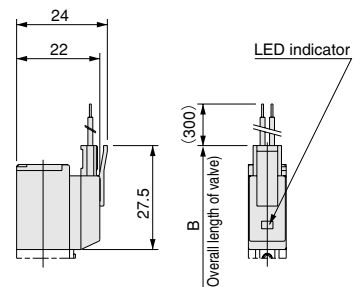
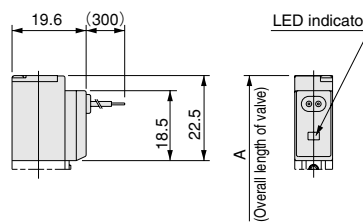
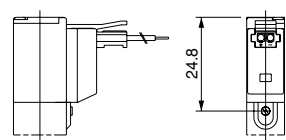
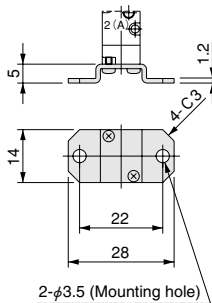

Model	Code	A	B	Remark
EB10F1~EB10F4, EB10A1~EB10A4		53	58	Overall length to the end of the valve
EB10LF1~EB10LF4, EB10LA1~EB10LA4		—	58	
EB10SF1~EB10SF4, EB10SA1~EB10SA4		—	58.7	

mm

# Dimensions of EB Series Manifold (mm)

For 2, 3-port

## EBM□F (Direct piping type)

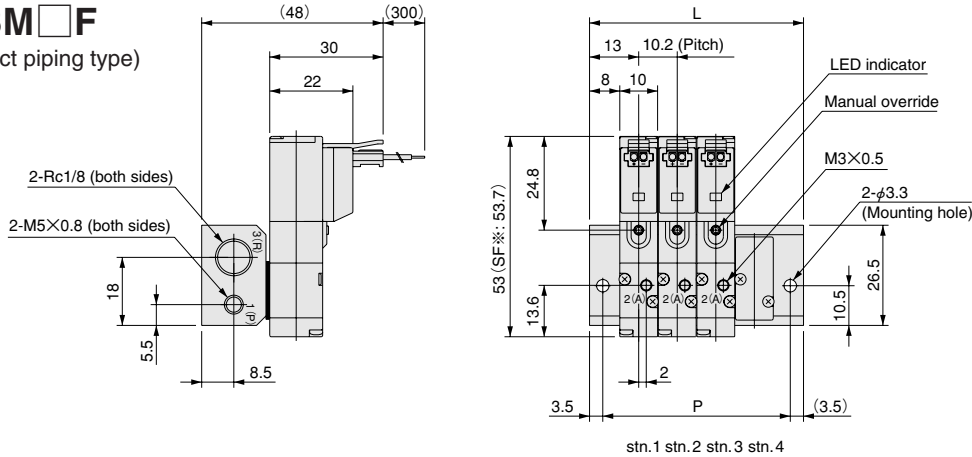

[Installation example]

- EBM4F**  
 stn.1 EB10F1-PL-D4  
 stn.2 EB10F3-PL-D4  
 stn.3 EB10F4-PL-D4  
 stn.4 EBBP-F

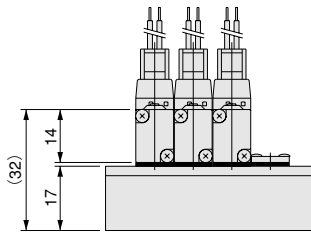

### Unit dimensions

Number of units	L	P
2	36.2	29.2
3	46.4	39.4
4	56.6	49.6
5	66.8	59.8
6	77.0	70.0
7	87.2	80.2
8	97.4	90.4
9	107.6	100.6
10	117.8	110.8
11	128.0	121.0
12	138.2	131.2
13	148.4	141.4
14	158.6	151.6
15	168.8	161.8
16	179.0	172.0
17	189.2	182.2
18	199.4	192.4
19	209.6	202.6
20	219.8	212.8

## EBM□A (Base piping type)

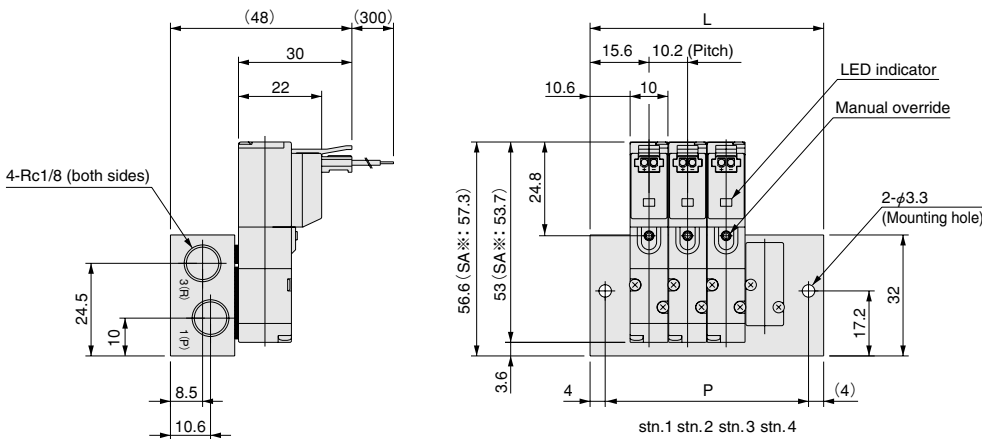

[Installation example]

- EBM4A**  
 stn.1 EB10A1-PL-D4  
 stn.2 EB10A3-PL-D4  
 stn.3 EB10A4-PL-D4  
 stn.4 EBBP-A

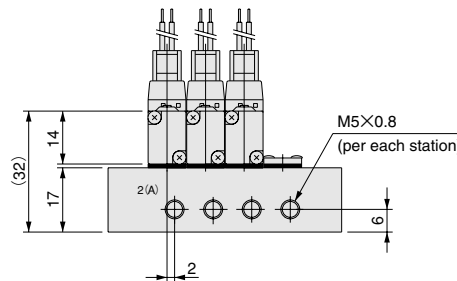

### Unit dimensions

Number of units	L	P
2	41.4	33.4
3	51.6	43.6
4	61.8	53.8
5	72.0	64.0
6	82.2	74.2
7	92.4	84.4
8	102.6	94.6
9	112.8	104.8
10	123.0	115.0
11	133.2	125.2
12	143.4	135.4
13	153.6	145.6
14	163.8	155.8
15	174.0	166.0
16	184.2	176.2
17	194.4	186.4
18	204.6	196.6
19	214.8	206.8
20	225.0	217.0

# Dimensions of EB Series Manifold (mm)

For 2, 3-port

## EBM□AJ

(Base piping type with quick fittings)

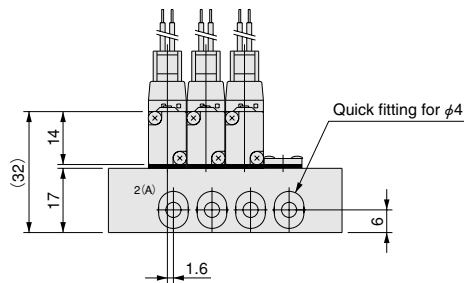
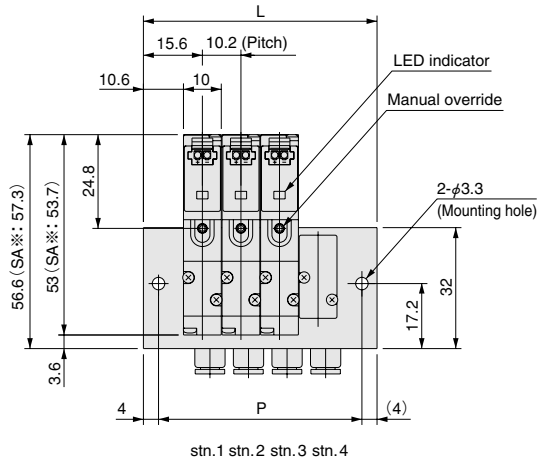
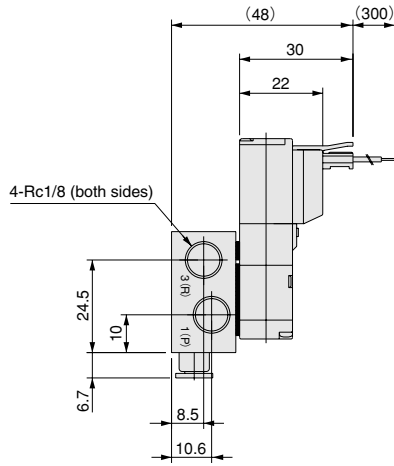

[Installation example]

- EBM4AJ**  
 stn.1 EB10A1-PL-D4  
 stn.2 EB10A3-PL-D4  
 stn.3 EB10A4-PL-D4  
 stn.4 EBBP-A

### Unit dimensions

Number of units	L	P
2	41.4	33.4
3	51.6	43.6
4	61.8	53.8
5	72.0	64.0
6	82.2	74.2
7	92.4	84.4
8	102.6	94.6
9	112.8	104.8
10	123.0	115.0
11	133.2	125.2
12	143.4	135.4
13	153.6	145.6
14	163.8	155.8
15	174.0	166.0
16	184.2	176.2
17	194.4	186.4
18	204.6	196.6
19	214.8	206.8
20	225.0	217.0





SOLENOID VALVES EA, EB SERIES



Before selecting and using products, please read all the Safety Precautions carefully to ensure proper product use. The Safety Precautions shown below are to help you use the product safely and correctly, and to prevent injury or damage to assets beforehand.

Follow the Safety Precautions for: ISO4414 (Pneumatic fluid power—Recommendations for the application of equipment to transmission and control systems), JIS B 8370 (Pneumatic system regulations)

**The directions are ranked according to degree of potential danger or damage: “DANGER!” “WARNING!” “CAUTION!” and “ATTENTION!”**

 <b>DANGER</b>	Expresses situations that can be clearly predicted as dangerous. If the noted danger is not avoided, it could result in death or serious injury. It could also result in damage or destruction of assets.
 <b>WARNING</b>	Expresses situations that, while not immediately dangerous, could become dangerous. If the noted danger is not avoided, it could result in death or serious injury. It could also result in damage or destruction of assets.
 <b>CAUTION</b>	Expresses situations that, while not immediately dangerous, could become dangerous. If the noted danger is not avoided, it could result in light or semi-serious injury. It could also result in damage or destruction of assets.
 <b>ATTENTION</b>	While there is little chance of injury, this content refers to points that should be observed for appropriate use of the product.

**■ This product was designed and manufactured as parts for use in General Industrial Machinery.**

- In the selection and handling of equipment, the system designer or other person with fully adequate knowledge and experience should always read the Safety Precautions, Catalog, User’s Manual and other literature before commencing operation. Making mistakes in handling is dangerous.
- After reading the Instruction Manual, Catalog, etc., always place it where it can be easily available for reference to users of this product.
- If transferring or lending the product to another person, always attach the Instruction Manual, Catalog, etc., to the product where it is easily visible, to ensure that the new user can use the product safely and properly.
- The danger, warning, and caution items listed under these “Safety Precautions” do not cover all possible cases. Read the catalog and user’s manual carefully, and always keep safety first.

 **DANGER**

- Do not use for the purposes listed below:
  1. Medical equipment related to maintenance or management of human lives or bodies.
  2. Mechanical devices or equipment designed for the purpose of moving or transporting people.
  3. Critical safety components in mechanical devices.
 This product has not been planned or designed for purposes that require advanced stages of safety. It could cause injury to human life.
- Do not use in locations with or near dangerous substances such as flammable or ignitable substances. This product is not explosion-proof. It could ignite or burst into flames.
- When attaching the product and workpiece, always ensure that it is securely mounted in place. Dropping or falling the product or improper operation could result in injury.
- Persons who use a pacemaker, etc., should keep a distance of at least one meter [3.28ft.] away from the product. There is a possibility that the pacemaker will malfunction due to the strong magnet built into the product.
- Never attempt to remodel the product. It could result in abnormal operation leading to injury, electric shock, fire, etc.
- Never attempt inappropriate disassembly, assembly or repair of the product’s basic construction, or of its performance or functions. It could result in injury, electric shock, fire, etc.
- Do not splash water on the product. Spraying it with water, washing it, or using it underwater could result in malfunction of the product leading to injury, electric shock, fire, etc.
- While the product is in operation, avoid touching it with your hands or otherwise approaching too close. In addition, do not make any adjustments to the interior or to the attached mechanisms (manual override, connecting and disconnecting of wiring connectors, adjustment of pressure switches, or release or connection of piping tubes or plugs) while in operation. The actuator can move suddenly, possibly resulting in injury.

 **WARNING**

- Do not use the product in excess of its specification range. Such use could result in product breakdowns, function stop or damage or drastically reduce the operating life.
- Before supplying air or electricity to the device and before starting operation, always conduct a safety check of the area of machine operation. Unintentional supply of air or electricity could possibly result in electric shocks, or in injury caused by contact with moving portion.
- Do not touch the terminal and the miscellaneous switches, etc., while the device is power on. There is a possibility of electric shock and abnormal operation.
- Do not allow the product to be thrown into fire. The product could explode and/or release toxic gases.
- Do not sit on the product, place your foot on it, or place other objects on it. Accidents such as falling and tripping over could result in injury. Dropping the product may result in injury, or also damage or break the product resulting in abnormal or erratic operation, or runaway etc.
- When conducting any kind of operation for the product, such as maintenance, inspection, repair, or connect/disconnect or replacement of piping, always turn off the air supply completely and confirm that residual pressure inside the product or in piping connected to the product is zero before proceeding. In particular, be aware that residual air will still be in the air compressor or air storage tank. The actuator could abruptly move if residual air pressure remains inside the piping, causing injury.
- Before commencing normal operation, always release the lock on the locking type manual override, and confirm that the manual override is in the normal position and that the main valve is in the proper switching position, and only then commence the operation. Failure to do so could lead to erroneous operation.
- Always shut off power when performing wiring operations. Leaving the power on could result in electric shocks.
- Apply the specified voltage for the solenoid. Using the wrong voltage level will prevent the solenoid from performing its function, and could lead to breakage or burn damage of the product itself.
- Avoid scratching the cords for the sensor switch lead wires, etc. Letting the cords be subject to scratching, excessive

bending, pulling, rolling up, or being placed under heavy objects or squeezed between two objects, may result in current leaks or defective transmission that lead to fires, electric shocks, or abnormal operation.

- Do not pull out the connectors while the power is ON. Also, do not put unnecessary stress on the connector. It could result in erroneous equipment operation that could lead to personal injury, equipment breakdown, or electrical shocks, etc.
- Always check the Catalog to ensure that the product wiring and piping is done correctly. Errors in wiring and piping could lead to abnormal operation of the actuators, etc.
- In the first operation after the equipment has been idle for 48 hours or more, or has been in storage, there is a possibility that contacting parts have been stuck, resulting in equipment operation delays or sudden movements. For these first operations, always run a test operation before use to check that operating performance is normal.
- In low frequency use (more than 30 days between uses), there is a possibility that contact parts will stick, resulting in equipment operation delays or sudden movements that could lead to personal injury. Run a test operation at least once every 30 days to confirm that movement is normal.
- For double solenoid type (excluding the Tandem 3-port valve), do not apply current through both solenoids simultaneously. It is impossible in such a situation to maintain the correct valve position, and the equipment may operate in an unintended direction, leading to the possibility of equipment breakdown or personal injury.
- Do not use the solenoid valves or the wiring that controls them, near power lines where large electrical currents are flowing, or in locations subject to powerful magnetic fields or power surges. Such application could lead to unintended operation.
- The solenoid valve can generate surge voltage and electromagnetic waves when the switch is turned off, affecting the operations of surrounding equipment. Use solenoids with surge suppression, or take countermeasures in the electrical circuits for surges or electromagnetic waves.
- Do not use where ozone may be generated, such as near ocean beaches or other places subject to direct sunlight or mercury lamps. Ozone can cause rubber parts to deteriorate, which can lead to degraded performance and functions, or to equipment stoppages and functional shutdown. (Excludes items where measures against ozone have been taken.)
- Do not use any media other than shown on the specifications. Use of non-specified media could lead to functional shutdown after a short period, to sudden performance drops, or to shorter operating life.
- If mounting the solenoid valve inside a control panel, or if energizing it for long periods, provide heat radiation measures to ensure that temperatures surrounding the solenoid valve always remain within the specified temperature range. If energizing the unit for long periods, consult us.
- After finishing wiring operations, always check to ensure that no wiring connection errors exist before turning on the power.
- Do not collect the exhaust lines for air cylinders, etc. with pilot exhaust lines for solenoid valves into the same piping, etc. Interference in the exhaust could result in erratic operation.

### CAUTION

- When mounting the product, leave room for adequate working space around it. Failure to ensure adequate working space will make it more difficult to conduct daily inspections or maintenance, which could eventually lead to system shutdown or damage to the product.
- For mounting or transport of heavy products, use a lift, supporting tool, or several people, to provide firm support, and proceed with due caution to ensure personal safety.
- Do not bring floppy disks or magnetic media, etc., within one meter [3.28ft.] of the product. There is the possibility that the data on the floppy disks will be destroyed due to the magnetism of the magnet.
- If leakage current is occurring in the control circuit, there is a possibility of the product performing an unintended operation. Take measures against current leaking in the control circuit, to ensure that the leakage current value does not exceed the allowed range in the product specifications.

- Do not block the product's breathing holes. Pressure changes occur due to changes in volume during operation. Blocking the breathing holes destroys the pressure balance, and could cause failure of the intended operation, equipment damage, or personal injury.
- Do not use the solenoid valve in locations subject to large electrical currents or magnetic fields. It could result in erratic operation.
- Oily materials from the compressor (excluding the oil-free compressor) can cause drastic deterioration in product performance, and even a functional shutdown. Always install a mist filter before pneumatic equipment to remove the oily component.
- The properties of the lubrication oil can change when used in dry air where dew point temperatures is lower than  $-20$  degrees Celsius [ $-4^{\circ}\text{F}$ ]. It could result in degraded performance or in functional shutdown.
- Do not use the product in locations of direct sunlight (ultraviolet), in locations subject to dust, salt, or iron powder, in locations with humidity and high temperature, or in the media and/or the ambient atmospheres that include organic solvents, phosphoric ester type hydraulic oil, sulfur dioxide, chlorine gas, or acids, etc. These conditions could lead to functional shutdowns, sudden degraded performance, or shortened operating life in a brief period of time. For materials used, see Major Parts and Materials.

### ATTENTION

- When considering the possibility of using this product in situations or environments not specifically noted in the Catalog or User's Manual, or in applications where safety is an important requirement, such as in an airplane facility, combustion equipment, leisure equipment, safety equipment and other places where human life or assets may be greatly affected, take adequate safety precautions such as application with enough margins for ratings and performance or fail-safe measures. Be sure to consult us with such applications.
- Always check the catalog and other reference materials for product wiring and piping.
- Install a muffler, etc. on the exhaust port. It is effective in reducing exhaust noise.
- When handling the product, wear protective gloves, safety glasses, safety boots, etc. to keep safety.
- When the product can no longer be used, or is no longer necessary, dispose of it appropriately as industrial waste.
- Pneumatic equipment can exhibit degraded performance and function over its operating life. Always conduct daily inspections of the pneumatic equipment, and confirm that all requisite system functions are satisfied, to prevent accidents from happening.
- Air leaks from the valve are not zero. For application of requiring holding pressure (including vacuum) inside the pressure vessel, consider adequate margin of capacity and holding time in design of the system.
- For inquiries about the product, consult your nearest Koganei sales office or Koganei overseas department. The address and telephone number is shown on the back cover of this catalog.

### OTHERS

- Always observe the following items.
  1. When using this product in pneumatic systems, always use genuine KOGANEI parts or compatible parts (recommended parts). When conducting maintenance and repairs, always use genuine KOGANEI parts or compatible parts (recommended parts). Always observe the required methods and procedure.
  2. Do not attempt inappropriate disassembly or assembly of the product relating to basic construction, or its performance or functions.

Koganei cannot be responsible if these items are not properly observed.



# General Precautions

## Mounting

1. While any mounting direction is allowed, be sure to avoid strong shocks or vibrations applied directly to the body. Also, avoid strong shocks in the lateral direction when using a mounting base for installation. For the order code, see the Additional Parts item under each series.
2. Avoid using in the locations and environment listed below, as it could result in malfunction of the valve. If use in such conditions is unavoidable, always provide a cover or other adequate protective measures.
  - Location directly exposed to water drops or oil drops
  - Environment where a valve body is subject to dew condensation
  - Location directly exposed to machining chips, dust, etc
3. Install a muffler, etc. in the exhaust port to prevent dust from entering into the piping.
4. In piping connection with valves, flush the tube completely (by blowing compressed air) before piping. Intrusion of machining chips or sealing tape, rust, etc., generated during plumbing could result in air leaks and other defective operations.
5. When mounting a valve unit inside the control panels or when the operation requires long energizing periods, consider providing heat radiation measure such as ventilation.
6. Never use the valve with the 4(A) and 2(B) ports vent to atmosphere.

## Media

1. Use air for the media. For the use of any other media, consult us.
2. Air used for the cylinder should be clean air that contains no deteriorated compressor oil, etc. Install an air filter (filtration of 40 μm or less) near the valve to remove collected liquid or dust. In addition, drain the air filter periodically.
3. When supply pressure is low, use piping for the 1(P) port with sufficient tube size.

## Lubrication

Can be used without lubrication. When the actuator requires lubrication, use Turbine Oil Class 1 (ISO VG32) or the equivalent. Avoid using spindle oil or machine oil.

## Atmosphere

The product cannot be used when the media or ambient atmosphere contains any of the substances listed below. Organic solvents, phosphate ester type hydraulic oil, sulphur dioxide, chlorine gas, or acids, etc.

## How to find the flow rate

Subsonic speed flow when  $P_1 + 0.1013 < 1.89 (P_2 + 0.1013)$

$$Q = 226S \sqrt{\Delta P (P_2 + 0.1013)}$$

Sonic speed flow when  $P_1 + 0.1013 \geq 1.89 (P_2 + 0.1013)$

$$Q = 113S (P_1 + 0.1013)$$

Q: Air flow rate [ℓ/min (ANR)]

S: Effective area [mm<sup>2</sup>]

ΔP: Pressure drop  $P_1 - P_2$  [MPa]

P<sub>1</sub>: Upstream pressure [MPa]

P<sub>2</sub>: Downstream pressure [MPa]

※ Corrections for variances in air temperature  
Multiply the flow rate calculated in the formula above by the coefficients in the table below.

Air temperature °C [°F]	-20 [-4]	-10 [14]	0 [32]	10 [50]	30 [86]	40 [104]	50 [122]	60 [140]
Correction coefficient	1.08	1.06	1.04	1.02	0.98	0.97	0.95	0.94

## Piping

Since the 1(P) and exhaust ports are on both ends of the manifold, piping direction can be selected depending on the application (excluding some models). At shipping, plugs are temporarily screwed in ports at one end, but are not firmly tightened. Regardless of which end piping is connected, always remove the plugs, use sealing tape or apply other sealing agent, and securely tighten the plugs into the unused ports.

### 1. Sealing tape wrapping method

- ① Before piping, use air blowing (flushing) or cleaning to eliminate any machining chips, cutting oil, or dust, etc., remaining inside the pipes.
- ② When screwing in piping or fittings, caution should be taken to avoid letting machining chips or sealing materials from entering into the valves. When using sealing tape, wrap it so that 1.5~2 screw threads remain.

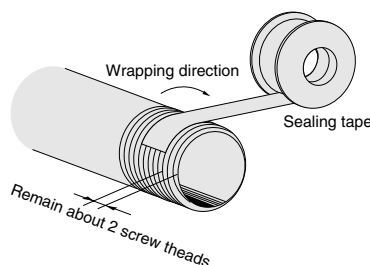

## 2. Tightening torque for piping

Connection thread	Suitable tightening torque N·cm (kgf·cm) [in·lbf]
M3	59 (6) [5.2]
M5×0.8	157 (16) [13.9]
Rc (PT) 1/8	686~883 (70~90) [60.8~78.1]
Rc (PT) 1/4	1177~1373 (120~140) [104~122]
Rc (PT) 3/8	2157~2354 (220~240) [191~208]
Rc (PT) 1/2	2746~2942 (280~300) [243~260]
Rc (PT) 3/4	2746~2942 (280~300) [243~260]
Rc (PT) 1	3530~3727 (360~380) [313~330]
Rc (PT) 1 1/4	3923~4119 (400~420) [347~365]
Rc (PT) 1 1/2	4707~4903 (480~500) [417~434]

## Block-off plate

To close the unused stations, use a block-off plate.

For the order code, see the Additional Parts item under each series.

- Cautions:**
1. For the 1(P) port piping, use a size that matches the manifold's piping connection port.
  2. When installing piping or mufflers to the exhaust port, ensure there will be minimum exhaust resistance.
  3. On rare occasions, exhaust can interfere with other valves and actuators. In this case, let exhaust from the R ports on both ends.
  4. When a multiple number of valves are operating simultaneously on a multi-unit manifold, or during high frequency applications, supply air from the 1(P) ports on both ends, and let exhaust from the R ports on both ends.
  5. Since the twin solenoid valve uses 2 stations, it cannot be mounted on the final station.
  6. In the 025 series, the seal between the valve and manifold is used reversed top-to-bottom, in accordance with the valve function (NC or NO). Install the seal as the mark (NC or NO) is located on the valve side and matches the valve function.

## Tube installation and removal

Insert the tube to connect as far as the tube stopper contacts the tubes. Pull the tube to confirm the connection.

For tube removal, push the release ring forward parallel to the ring, and pull the tube out.

## Tubes

Either nylon or urethane tubes can be used. Use tubes that are not scratched on their outer surface.

The tube's outer diameter tolerance should be within ±0.1mm [±0.004in.] of the nominal dimension, and within 0.2mm [0.008in.] for the ellipticity (difference between long and short diameter).

**Caution:** Do not excessively bend the tube near fittings.