

SOLENOID VALVES HJC, HJE SERIES INDEX

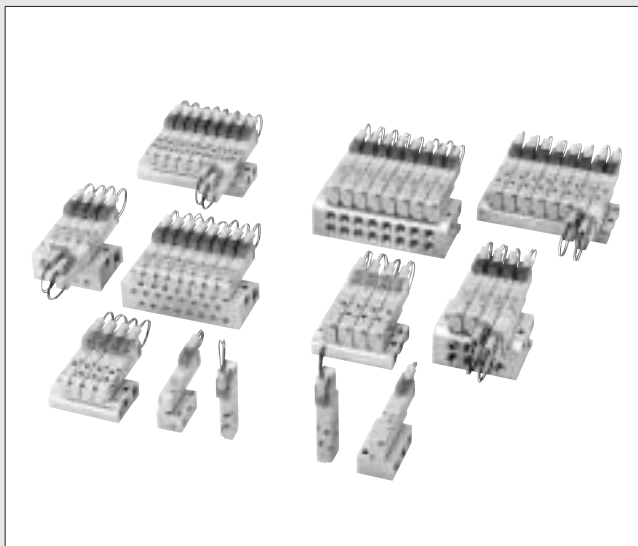

Features	229
Product Range	231
Handling Instructions and Precautions	232
HJC Series	
Specifications	235
Order Codes	239
Dimensions	242
HJE Series	
Specifications	249
Order Codes	253
Dimensions	256

Easy-to-use, simple construction valves!
 Suitable for various needs and offering high-performance control, while achieving still lower power consumption, quicker response, and a larger flow rate!

New Standard Valve Solenoid Valves HJC, HJE
 (2, 3, 5-port pilot type solenoid valves)

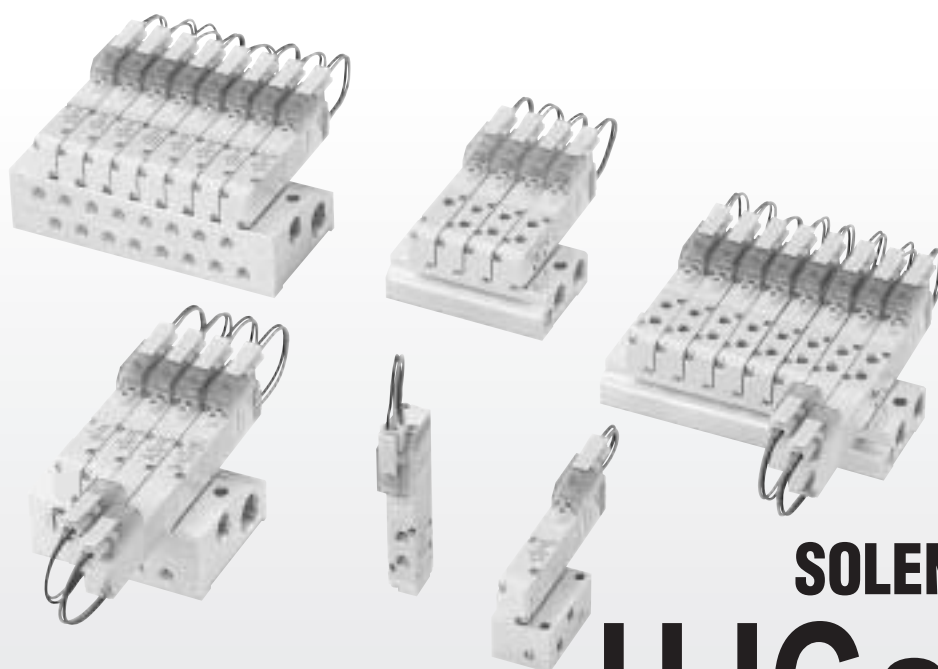

SOLENOID VALVES
HJC series

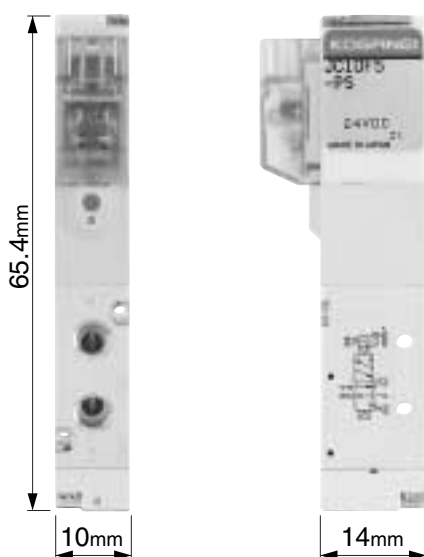

- **Space Saving—Thin and compact size**
 Valve width: 10mm [0.394in.]
 Valve length: 65.4mm [2.575in.]
- **Flow—Large flow rate with a compact body**
 Sonic conductance C: 0.6dm³/(s·bar)
 (Effective area S: 3.0mm² [Cv: 0.17])
 Optimum for operating up to ϕ 40 bore size cylinders.
- **Response—Quick response**
 Response time: When ON, 6ms or below
 When OFF, 7ms or below
 (in the case of quick response type single solenoid)
- **Power—Lower power consumption**
 Standard type: 0.55W, Low current type: 0.15W

Provides sure performance for all situations in which solenoid valves are required, in the manufacturing lines, in machinery, or in equipment. A NEW standard in compact valves!

● **Reliability—Improved reliability**

New solenoid and stem construction resulting for years of valve technology experience have boosted operating life, response, and other basic performance features.

● **Option—Mountable on DIN rail**

The A type manifold (base piping type) can be mounted on a DIN rail.
(for both the JC and JE series)



● **Environmental Protection—Improved performance**

Grommet type valves offer moisture proof specification.

(for both the JC and JE series)

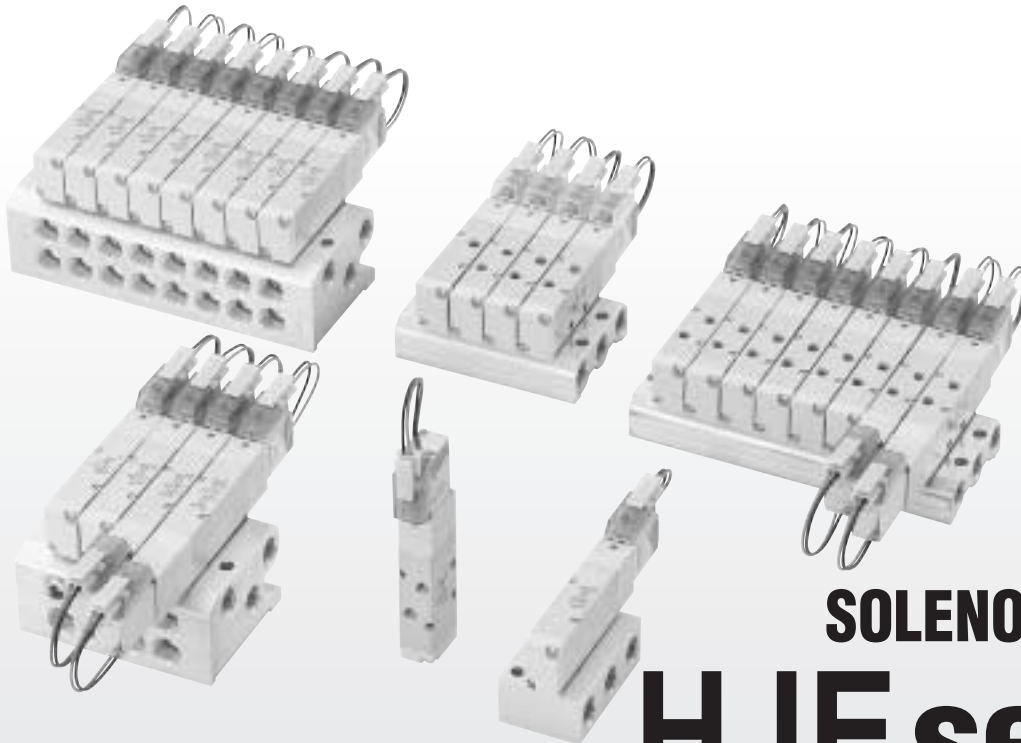

SOLENOID VALVES HJE series

SOLENOID VALVES HJC, HJE SERIES

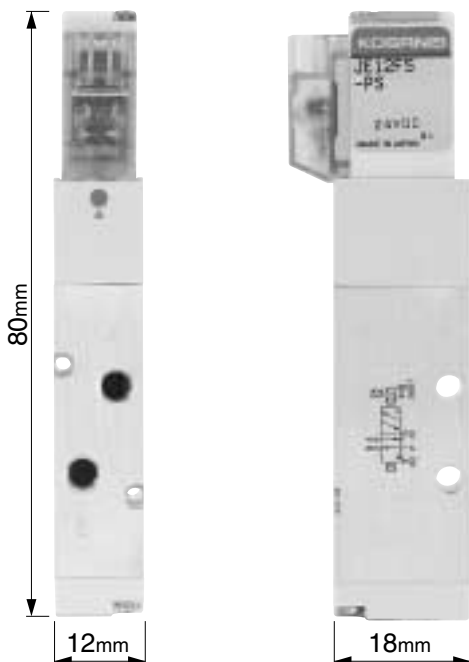

● **Space Saving—Thin and compact size**

Valve width: 12mm [0.472in.]
Valve length: 80mm [3.150in.]

● **Flow—Large flow rate with a compact body**

Sonic conductance C: 1.9dm³/(s·bar)
(Effective area: 9.5mm² [Cv: 0.53])
Optimum for operating up to ϕ 80 bore size cylinders.

● **Response—Quick response**

Response time: When ON, 6ms or below
When OFF, 10ms or below
(for quick response type single solenoid)

● **Power—Lower power consumption**

Standard type: 0.55W, Low current type: 0.15W

● **Safety—Configured to prevent erroneous operations**

Lever type manual override with erroneous operation prevention mechanism improves safety. (JE series only)



—Product Variety—
Provides a wide product range

Solenoid Valves HJC Series

Solenoid Valves HJE Series

**Single unit
(direct piping)**

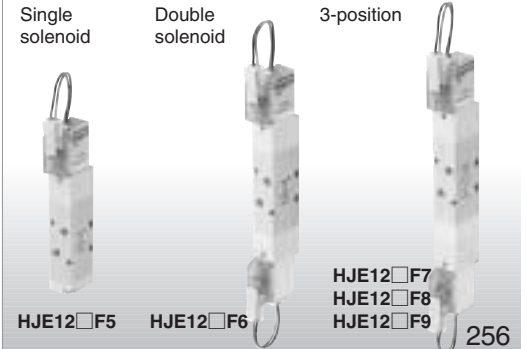
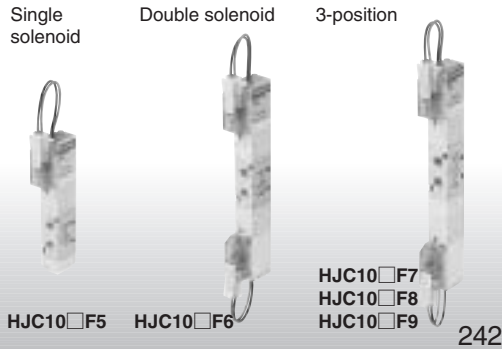

**Single unit
(base piping)**

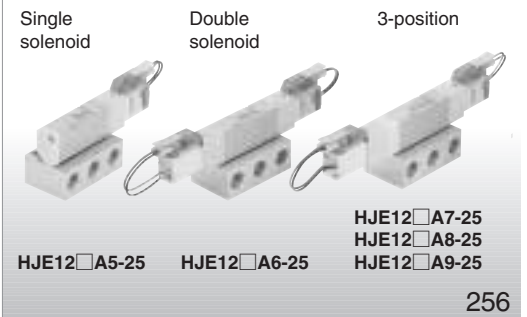
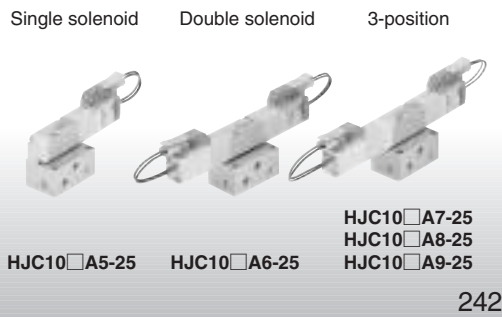

**F type manifold
(direct piping type)**

Manifold for combination mounting of 2, 3, 5-port valves

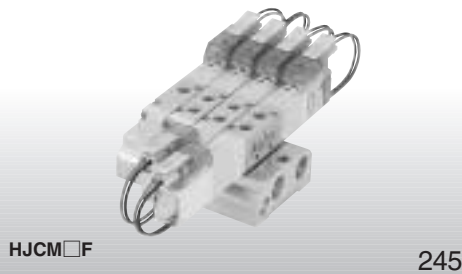

Manifold for combination mounting of 2, 3, 5-port valves

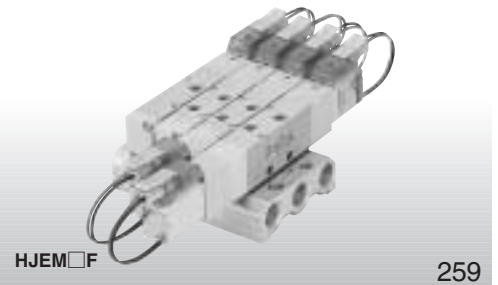

**A type manifold
(base piping type)**

Manifold for combination mounting of 2, 3, 5-port valves

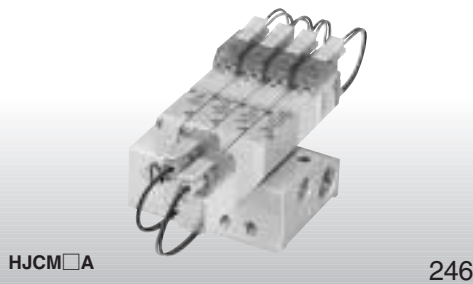

Manifold for combination mounting of 2, 3, 5-port valves

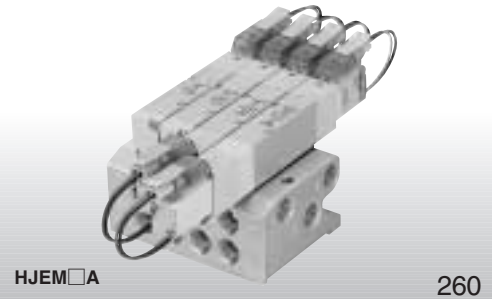

Function-specific solenoids (for both HJC and HJE series)

● Standard, low current and quick response types can be identified by the color of their housings.

Standard type: Blue



Low current type: Light blue



Quick response type: White





Solenoid

Internal circuit

●DC12V, DC24V

(Standard type)

Solenoid with LED indicator and surge suppression

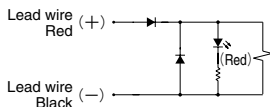

●DC24V

(Low current, quick response types)

Solenoid with LED indicator and surge suppression

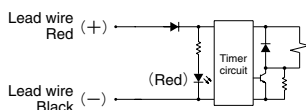

- Cautions:**
1. Do not apply megger between the pins.
 2. Leakage current inside the circuit could result in failure of the solenoid valve to return to the rest position or other erratic operation. Always use it at less than the allowable leakage current shown in the solenoid specifications on p.235, and 249. If circuit conditions, etc. cause the leakage current to exceed the maximum allowable leakage current, consult us.
 3. For the double solenoid configuration, avoid energizing both solenoids simultaneously.
 4. The standard housing type is colored blue, while the low current type is light blue, and the quick response type is white.
 5. The low current and quick response types will not activate when the power supply voltage is raised too slowly. Always apply the appropriate voltage.

Operating principles of low current and quick response types

The low current and quick response types use a timer circuit, as shown above, that achieves power savings by switching to the holding operations mode after a certain period of time and operates at about 1/3 of the starting power consumption.

●Power waveform for low current type

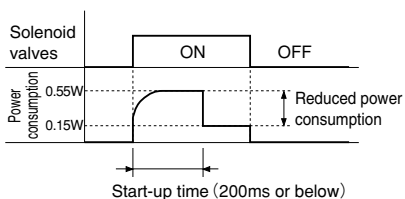

●Power waveform for quick response type

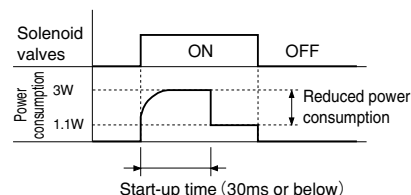

Plug connector

Attaching and removing plug connector

Use fingers to insert the connector into the pin, push it in until the lever claw latches onto the protruded section of the connector housing, and complete the connection. To remove the connector, squeeze the lever along with the connector, lift the lever claw up from the protruded section of the connector housing, and pull it out.

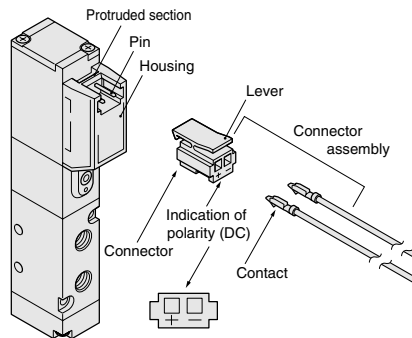

Crimping of connecting lead wire and contact

To crimp lead wires into contacts, strip off 4mm [0.16in.] of the insulation from the end of the lead wire, insert it into the contact, and crimp it. Be sure to avoid catching the insulation on the exposed wire crimping section.

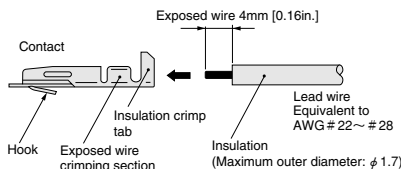

- Cautions:**
1. Do not pull hard on the lead wire.
 2. Always use a dedicated tool for crimping of connecting lead wire and contact.

Contact: Model 702062-2M
Manufactured by Sumiko Tech, Inc.

Crimping tool: Model F1-702062
Manufactured by Sumiko Tech, Inc.

Attaching and removing contact and connector

Insert the contact with lead wire into a plug connector □ hole until the contact hook latches on and is secured to the plug connector. Confirm that the lead wire cannot be easily pulled out.

To remove it, insert a tool with a fine tip (such as a small screwdriver) into the rectangular hole on the side of the plug connector to push up on the hook, and then pull out the lead wire.

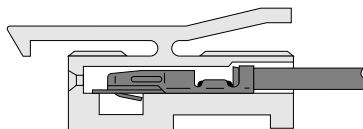

- Cautions:**
1. Do not pull hard on the lead wire. It could result in defective contacts, breaking wires, etc.
 2. If the pin is bent, use a small screwdriver, etc. to gently straighten out the pin, and then complete the connection to the plug connector.



Side mounting precautions (JE series)

When using a JE series single solenoid valve unit in a side mounting, as shown in the diagram below, mounting base -22 for the side mounting is required, because the fitting interferes with the mounting surface. The **TS6-M5** and **TL6-M5** quick fitting standard types for the 6mm tube cannot be mounted. Use the hexagon socket straight fitting or the quick fitting mini type instead.

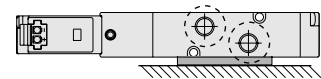

Manual override

Non-locking type

To operate the manual override, press it all the way down.

For the single solenoid, the valve works the same as when in the energized state as long as the manual override is pushed down, and returns to the rest position upon release.

For the double solenoid, pressing the manual override on the 14 (SA) side switches the 14 (SA) to the energized state, and the valve remains in that state even after the manual override is released. To return it to the rest position, operate the manual override on the 12 (SB) side. This is the same for the solenoid 12 (SB).

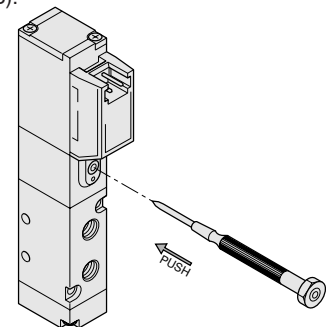

Locking type

To lock the manual override, use a small screwdriver to push down on the manual override all the way down and turn it clockwise 45 degrees. When locked, turning the manual override 45 degrees in the counterclockwise direction returns it to its rest position, and releases the lock. (Excluding the quick response type)

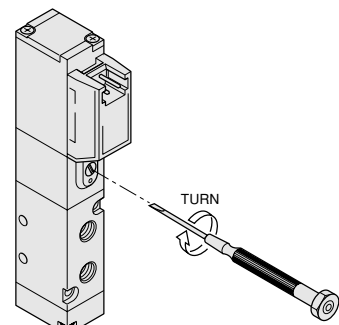

Lever type (JE series only)

To lock the manual override, push the manual lever all the way down and turn it clockwise 90 degrees. When locked, turning the manual lever 90 degrees in the counterclockwise direction returns it to its rest position and releases the lock. When the manual lever is not turned, this type acts just like the non-locking type, and the valve remains in the energized state as long as the manual lever is pushed down, and returns to the rest position upon release.

The manual lever is equipped with a safety plate to avoid erroneous operation. Care should be taken that the safety plate cannot be operated when the manual lever is locked in place.

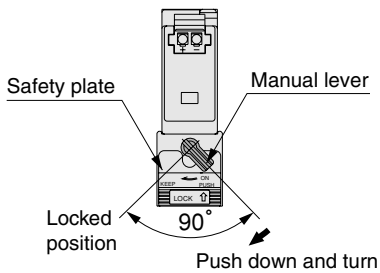

● Safety plate operation

- ① Check that the manual lever is in the off position.
- ② Slide the center of the safety plate in the direction shown by the arrow until it comes to a stop, at a distance of about 3mm [0.12in.]. In this position, the manual lever can no longer be pushed in.
- ③ To release the safety plate, slide it in the direction opposite to that shown by the arrow until it comes to a stop.

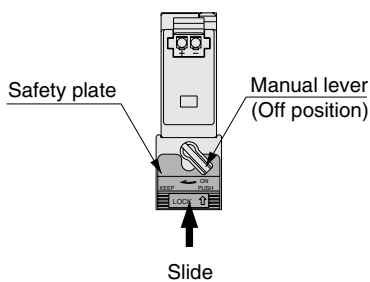

- Cautions:**
1. The JC and JE series are pilot type solenoid valves. As a result, the manual override button or manual lever cannot switch the main valve without air supplied from the 1(P) port.
 2. Always release the lock of the manual override button or manual lever before commencing normal operation.
 3. Do not attempt to operate the manual override button or manual lever with a pin or other object having an extremely fine tip. It could damage the button.
 4. For the lever type, do not apply excessive force when sliding the safety plate. It could result in a breakdown. (Recommended force: 3N)

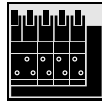

Manifold

Mounting on a DIN rail (A type manifold)

With the DIN rail mounting bracket option, a mounting bracket and mounting screw are provided. First, use the mounting screw to temporarily secure the mounting bracket on the manifold.

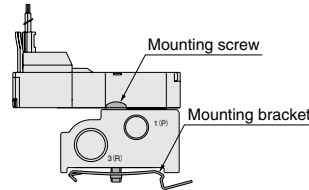

● Mounting

- ① Approaching from the direction shown in the diagram, let the mounting bracket hook latch onto the DIN rail fringe, then press down the manifold to secure the bracket onto the DIN rail.

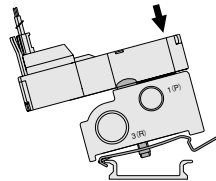

- ② To ensure that the mounting bracket is firmly set against the bottom of the manifold, tighten the mounting screw to secure the DIN rail in place. Recommended tightening torque: 98N·cm {10kgf·cm} [8.7in·lbf]

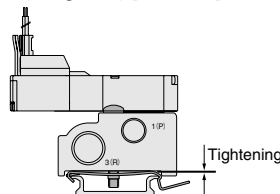

Caution: Since the mounting bracket cannot slide along the DIN rail once it is set onto the rail, make sure to set the manifold in the appropriate position beforehand.

● Removing

- ① Loosen the mounting screw and lift the manifold off and away from the mounting bracket.
- ② Insert a flatblade screwdriver, etc. underneath the mounting bracket's release lever, and gently pry it away to remove the mounting bracket.

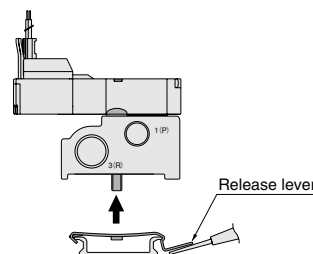

Cautions: Spring force from the mounting bracket's plate could cause the bracket to pop out during the removal operation. To ensure safety, proceed with caution during the operation. In addition, always use a flatblade screwdriver, etc. when removing the mounting bracket from the DIN rail. Never use your fingers because of the danger of serious injury due to the potential strong forces.

● Vertical mounting

When mounting the manifold in a vertical direction, mount it so that the release lever is pointing downward.

Caution: Caution should be taken not to drop the manifold.

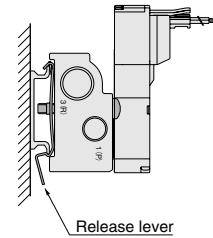

Mounting a valve on the manifold

When mounting a valve on the manifold, the recommended tightening torque for the valve mounting screw is 14.7N·cm {1.5kgf·cm} [1.30in·lbf].

Tube

1. Attaching and removing tubes

For tube connection, insert an appropriate size tube until it comes into contact with the tube stopper, and lightly pull it to check the connection.

For tube removal, push the tube against the tube stopper, then push the release ring and at the same time pull the tube out.

2. Either a nylon or urethane tube can be used.

Use tubes with an outer diameter tolerance within $\pm 0.1\text{mm}$ [$\pm 0.004\text{in.}$] of the nominal diameter, and ensure the ovalness (difference between large diameter and small diameter) is 0.2mm [0.008in.] or less. (Using Koganei tubes is recommended.)

- Cautions:**
1. Do not use extra-soft tubes since their pull-out strength is significantly reduced.
 2. Only use tubes without scratches on their outer surfaces. If a scratch occurs during repeated use, cut off the scratched section.
 3. Do not bend the tube excessively near the fittings. The minimum bending radius is as shown in the table below.
 4. When attaching or removing tubes, always stop the air supply. In addition, always confirm that air has been completely exhausted from the manifold.

Tube size	Minimum bending radius	
	Nylon tube	Urethane tube
φ3	—	7 [0.28]
φ4	20 [0.79]	10 [0.39]
φ6	30 [1.18]	15 [0.59]
φ8	50 [1.97]	20 [0.79]

Solenoid Valves HJC Series

(2, 3, 5-port pilot type solenoid valves)

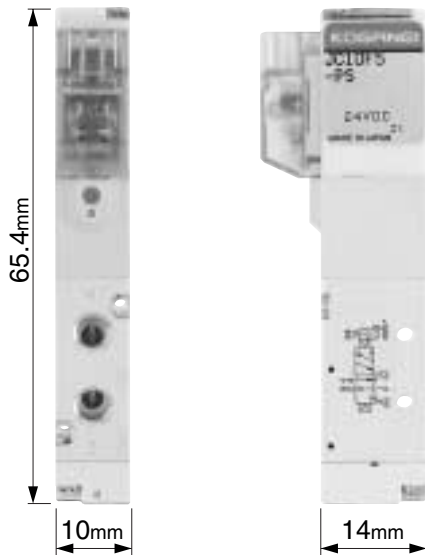

- **Space Saving—Thin and compact size**

Valve width: 10mm [0.394in.]
Valve length: 65.4mm [2.575in.]

- **Flow—Large flow rate with a compact body**

Sonic conductance C: 0.6dm³/(s·bar)
(Effective area S: 3.0mm² [Cv: 0.17])
Optimum for operating up to ϕ 40 bore size cylinders.

- **Response—Quick response**

Response time: When ON, 6ms or below
When OFF, 7ms or below
(in the case of quick response type single solenoid)

- **Power—Lower power consumption**

Standard type: 0.55W, Low current type: 0.15W

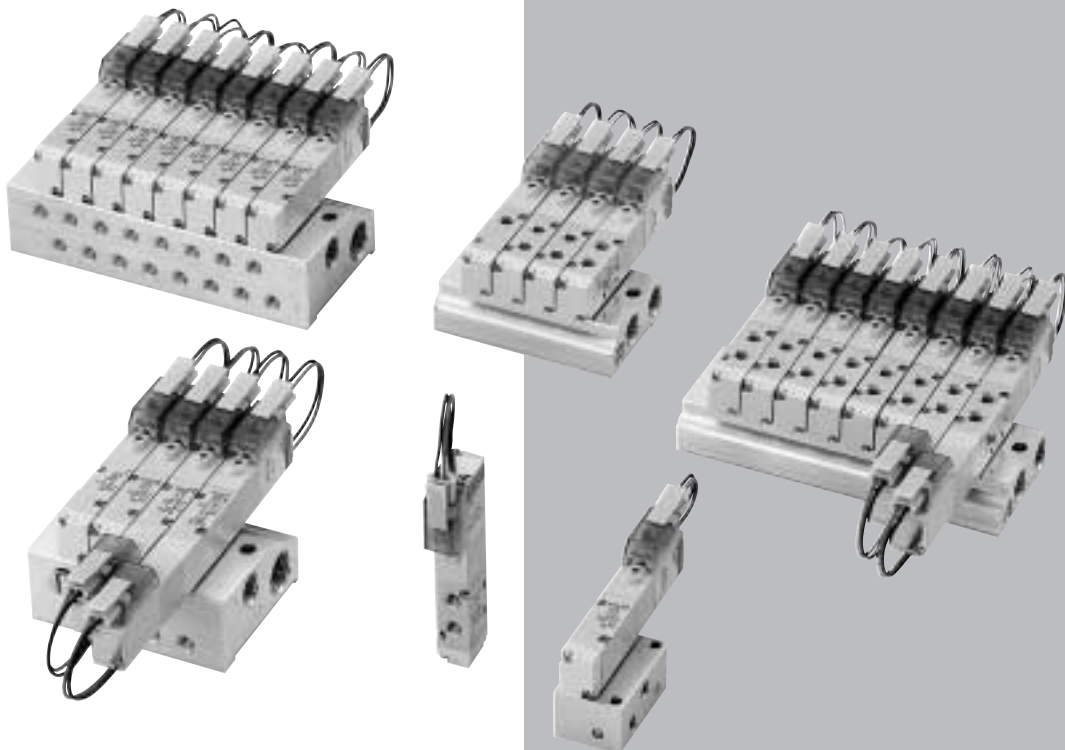

HJC SERIES SPECIFICATIONS

Specifications

Basic Models and Functions

Basic model	For direct piping, F type manifolds	HJC10□F1 ^{Note} HJC10□F2 ^{Note} HJC10□F3 ^{Note} HJC10□F4 ^{Note}	HJC10□F5	HJC10□F6	HJC10□F7 HJC10□F8 HJC10□F9
	For base piping, A type manifolds	HJC10□A1 ^{Note} HJC10□A2 ^{Note} HJC10□A3 ^{Note} HJC10□A4 ^{Note}	HJC10□A5	HJC10□A6	HJC10□A7 HJC10□A8 HJC10□A9
Item					
Number of positions		2 positions			3 positions
Number of ports		2, 3 ports	5 ports		
Valve function		Single solenoid NC, NO	Single solenoid	Double solenoid	Closed center, Exhaust center, Pressure center

Remark: For the optional specifications and order codes, see p.239.

Note: Valves with valve specifications F1, F2, F3, F4, A1, A2, A3, and A4 are for mounting on manifolds only, and cannot be used as single valve units.

Specifications

Basic model	For direct piping, F type manifolds	HJC10□F1 HJC10□F2 HJC10□F3 HJC10□F4	HJC10□F5	HJC10□F6	HJC10□F7 HJC10□F8 HJC10□F9
	For base piping, A type manifolds	HJC10□A1 HJC10□A2 HJC10□A3 HJC10□A4	HJC10□A5	HJC10□A6	HJC10□A7 HJC10□A8 HJC10□A9
Item					
Media		Air			
Operation type		Internal pilot type			
Flow rate characteristics ^{Note 1} Sonic conductance C dm ³ /(s·bar)		0.6			
Port size ^{Note 2}		10-32 UNF			
Lubrication		Not required			
Operating pressure range MPa {kgf/cm ² }[psi.]		0.2~0.7 {2~7.1} [29~102]		0.25~0.7 {2.5~7.1} [36~102]	
Proof pressure MPa {kgf/cm ² }[psi.]		1.05 {10.7} [152]			
Response time ^{Note 3} ON/OFF	ms	Standard type	10/20 or below	12 or below	10/30 or below
		Low current type (L)	10/50 or below	12 or below	10/60 or below
		Quick response type (S)	6/7 or below	6 or below	6/12 or below
Maximum operating frequency	Hz	Standard type	5		
		Low current type (L)	2		
		Quick response type (S)	10		
Minimum time to energize for self holding ^{Note 4}		ms	—	50	—
Operating temperature range (atmosphere and media)		°C [°F]			
Shock resistance		m/s ² {G}	1373.0 {140} (Axial direction 294.2 {30})	1373.0 {140} (Axial direction 147.1 {15})	1373.0 {140} (Axial direction 195.0 {20})
Mounting direction		Any			

Notes: 1. For details, see the flow rate characteristics on p.236.

2. For details, see the port size on p.237.

3. Values when air pressure is 0.5MPa [73psi.]. The values for the 3-position valves are switching time from the neutral position.

4. For double solenoid valve.

Solenoid Specifications

Item	Rated voltage	DC12V	DC24V	DC24V	DC24V	
		(Standard type)	(Standard type)	(Low current type)	(Quick response type)	
Operating voltage range	V	10.8~13.2 (12±10%)	21.6~26.4 (24±10%)	21.6~26.4 (24±10%)	21.6~26.4 (24±10%)	
Standard type	Current (when rated voltage is applied)	mA (r.m.s)	46	23	—	
	Power consumption	W	0.55	0.55	—	
Low current type Quick response type	Current (when rated voltage is applied)	Starting	mA	—	23	
		Holding	mA	—	6.3	
	Power consumption	Starting	W	—	—	0.55
		Holding	W	—	—	0.15
Start-up time (standard time)	ms	—	—	200 or below	30 or below	
Allowable leakage current	mA	2	1	0.5	4	
Insulation resistance	MΩ	Over 100 (value at DC500V megger)				
Color of LED indicator		Red				
Surge suppression (as standard)		Flywheel diode				

Flow Rate Characteristics

The test method for flow rate characteristics conforms to JIS B 8390:2000 (test method for pneumatic equipment — equipment for compressible fluids — flow rate characteristics).

● When used as a single unit (with fittings)

Basic model		Flow path	Sonic conductance C dm ³ /(s·bar)	Critical pressure ratio b	Effective area S mm ² [Cv]			
Direct piping ^{Note 1}	HJC10□F5 HJC10□F6	1 (P) → 4 (A)	—	—	2.80 [0.156]			
		1 (P) → 2 (B)	—	—				
		4 (A) → 5 (R1)	—	—				
	HJC10□F7 HJC10□F8 HJC10□F9	1 (P) → 4 (A)	1 (P) → 2 (B)	—	—	2.50 [0.139]		
			4 (A) → 5 (R1)	—	—			
		2 (B) → 3 (R2)	1 (P) → 2 (B)	—	—			
			4 (A) → 5 (R1)	—	—			
		Base piping ^{Note 1} (with sub-base)	HJC10□A5 HJC10□A6	1 (P) → 4 (A)	0.58		0.40	2.90 [0.161] ^{Note 3}
				1 (P) → 2 (B)	0.57		0.37	2.85 [0.158] ^{Note 3}
4 (A) → 5 (R1)	0.51			0.29	2.55 [0.142] ^{Note 3}			
2 (B) → 3 (R2)	0.61			0.26	3.05 [0.169] ^{Note 3}			
HJC10□A7 HJC10□A8 HJC10□A9	1 (P) → 4 (A)		0.52	0.36	2.60 [0.144] ^{Note 3}			
	1 (P) → 2 (B)		0.53	0.33	2.65 [0.147] ^{Note 3}			
	4 (A) → 5 (R1)		0.49	0.27	2.45 [0.136] ^{Note 3}			
	2 (B) → 3 (R2)		0.55	0.27	2.75 [0.153] ^{Note 3}			

● When mounted on a manifold (with fittings)

Basic model		Flow path	Sonic conductance C dm ³ /(s·bar)	Critical pressure ratio b	Effective area S ^{Note 3} mm ² [Cv]		
F type manifold ^{Note 2} (direct piping type)	HJC10□F1 HJC10□F2 HJC10□F3 HJC10□F4 HJC10□F5 HJC10□F6	1 (P) → 4 (A)	0.66	0.54	3.30 [0.183]		
		1 (P) → 2 (B)	0.62	0.46	3.10 [0.172]		
		4 (A) → 5 (R1)	0.58	0.33	2.90 [0.161]		
		2 (B) → 3 (R2)	0.55	0.14	2.75 [0.153]		
		1 (P) → 4 (A)	0.56	0.41	2.80 [0.156]		
		1 (P) → 2 (B)	0.56	0.42	2.80 [0.156]		
	HJC10□F7 HJC10□F8 HJC10□F9	4 (A) → 5 (R1)	0.53	0.32	2.65 [0.147]		
		2 (B) → 3 (R2)	0.50	0.13	2.50 [0.139]		
		A type manifold ^{Note 2} (base piping type)	HJC10□A1 HJC10□A2 HJC10□A3	1 (P) → 4 (A)	0.61	0.33	3.05 [0.169]
				1 (P) → 2 (B)	0.60	0.31	3.00 [0.167]
				4 (A) → 5 (R1)	0.61	0.08	3.05 [0.169]
			HJC10□A4 HJC10□A5 HJC10□A6	2 (B) → 3 (R2)	0.60	0.08	3.00 [0.167]
1 (P) → 4 (A)	0.54			0.29	2.70 [0.150]		
1 (P) → 2 (B)	0.54			0.30	2.70 [0.150]		
HJC10□A7 HJC10□A8 HJC10□A9	4 (A) → 5 (R1)	0.57	0.08	2.85 [0.158]			
	2 (B) → 3 (R2)	0.54	0.09	2.70 [0.150]			

- Notes: 1. Quick fitting TSH6-M5Ms are mounted on connection ports 1(P), 2(B), and 4(A).
 2. Quick fitting TSH6-M5Ms are mounted on connection ports 2(B) and 4(A).
 3. Figures in effective area S are calculated based on sonic conductance C ($S=5.0 \times C$).

(Effective area $S=3.0\text{mm}^2$ [Cv: 0.17])

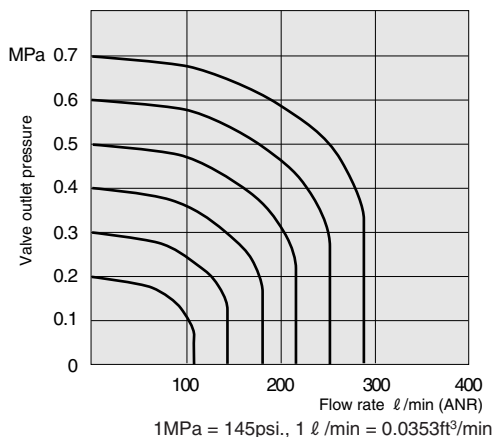

- The graph uses flow rate calculations based on the discharge method.
- Use the flow rate as a guide.

Port Size

Port specification		Port	2(B), 4(A)	1(P)	3, 5(R)
Single unit	Direct piping		10-32 UNF	10-32 UNF	M3×0.5
	Base piping (with sub-base)		10-32 UNF	10-32 UNF	10-32 UNF
Manifold	F type		10-32 UNF	NPT1/8	NPT1/8
	A type		10-32 UNF	NPT1/8	NPT1/4

Mass

Single Valve Unit Mass

g [oz.]

Basic model	Mass	Additional mass	
		-21 (with bottom mounting base)	-25 (with sub-base)
HJC10□F1	26 [0.92]	—	—
HJC10□F2			
HJC10□F3			
HJC10□F4			
HJC10□F5	26 [0.92]	4 [0.14]	—
HJC10□F6	40 [1.41]		
HJC10□F7	43 [1.52]	—	
HJC10□F8			
HJC10□F9			
HJC10□A1	26 [0.92]	—	—
HJC10□A2			
HJC10□A3			
HJC10□A4			
HJC10□A5	26 [0.92]	—	27 [0.95]
HJC10□A6	40 [1.41]		
HJC10□A7	43 [1.52]		
HJC10□A8			
HJC10□A9			

Manifold Mass

g [oz.]

Basic model	Mass calculation of each unit (n = number of units)	Block-off plate	With DIN rail mounting bracket
HJCM□F	$(12.5 \times n) + 20$ [(0.44×n)+0.71]	3 [0.11]	—
HJCM□A	$(22.5 \times n) + 42$ [(0.79×n)+1.48]		15 [0.53]

Calculation example: **HJCM8A**

stn.1~8 HJC10A5-PS-D4

$$(22.5 \times 8) + 42 + (26 \times 8) = 430\text{g} [15.17\text{oz.}]$$

5-port, 2-position

Single solenoid

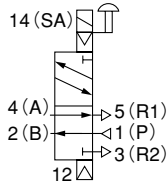

HJC10F5
De-energized

Double solenoid

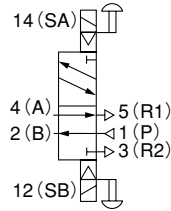

HJC10F6
[De-energized condition after energizing solenoid 12 (SB)]

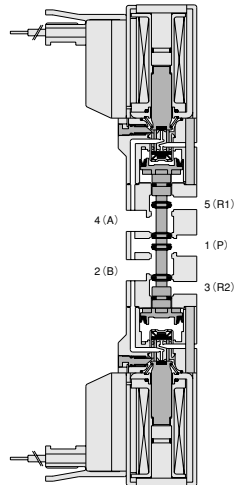
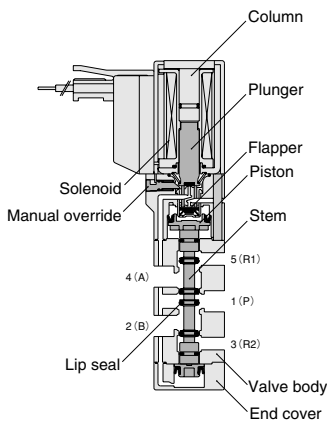

Major Parts and Materials

Parts	Materials
Body	Aluminum alloy
Stem	(anodized)
Lip seal	Synthetic rubber
Flapper	
Valve	
Mounting base	Mild steel (zinc plated)
Sub-base	Aluminum alloy (anodized)
Plunger	Magnetic stainless steel
Column	
End cover	Plastic
Manifold	
Body	Aluminum alloy (anodized)
Block-off plate	Mild steel (nickel plated)
Seal	Synthetic rubber

SOLENOID VALVES HJC, HJE SERIES

5-port, 3-position

[Both 14 (SA) and 12 (SB) are de-energized]

Closed center

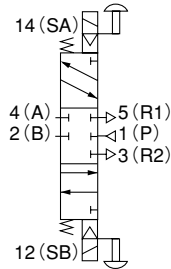

HJC10F7

Exhaust center

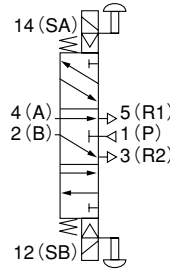

HJC10F8

Pressure center

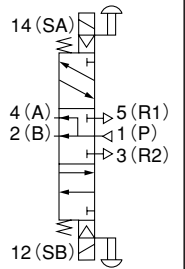

HJC10F9

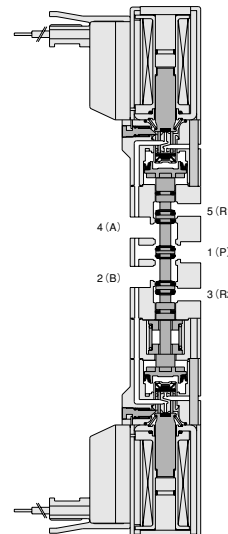
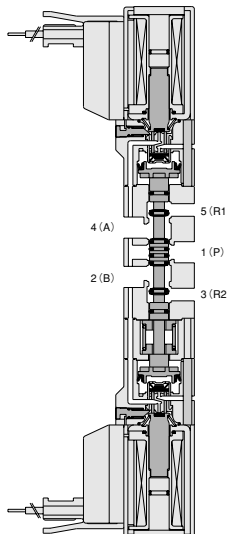
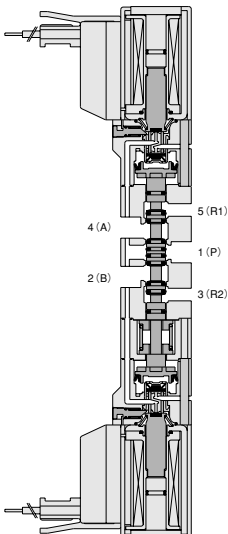

HJC Series Single Valve Unit Order Codes



Valve specification

- F1, A1: 2-port normally closed (NC)^{Note1}
- F2, A2: 2-port normally open (NO)^{Note1}
- F3, A3: 3-port normally closed (NC)^{Note1}
- F4, A4: 3-port normally open (NO)^{Note1}
- F5, A5: 5-port 2-position, single solenoid
- F6, A6: 5-port 2-position, double solenoid
- F7, A7: 3-position, closed center
- F8, A8: 3-position, exhaust center
- F9, A9: 3-position, pressure center

Model

- HJC10**
Standard type
- HJC10L**
Low current type
- HJC10S**
Quick response type

Sub-base

Without sub-base

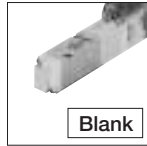

With sub-base

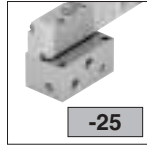

Manual override

Non-locking type

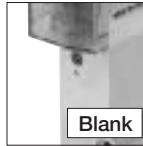

Locking type^{Note4}



Wiring specification

S type plug connector
Lead wire 300mm

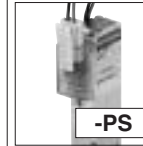

L type plug connector
Lead wire 300mm



S type plug connector
Lead wire 1000mm

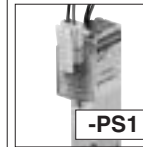

L type plug connector
Lead wire 1000mm

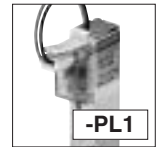

S type plug connector
Lead wire 3000mm

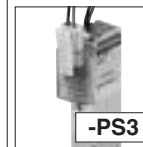

L type plug connector
Lead wire 3000mm



S type plug connector
Without connector ass'y



L type plug connector
Without connector ass'y



Grommet type^{Note5}
Lead wire 300mm
(moisture proof specification)



Voltage

- D4**
DC24V
- D5**
DC12V^{Note6}

300mm = [11.8in.]
1000mm = [39in.]
3000mm = [118in.]

Mounting base

Without mounting base

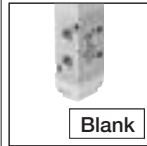

With mounting base

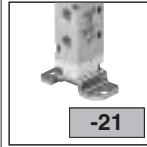

Muffler

Without muffler

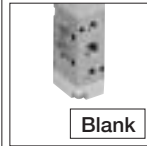

With muffler
for direct piping^{Note2}

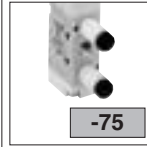

With muffler
for sub-base piping^{Note3}

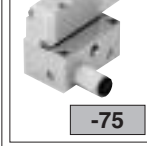

	Model	Valve specification	Mounting base	Sub-base	Muffler	Manual override	Wiring specification	Voltage
--	-------	---------------------	---------------	----------	---------	-----------------	----------------------	---------

Direct piping	HJC10 HJC10L HJC10S	F1 ^{Note1} F2 ^{Note1} F3 ^{Note1} F4 ^{Note1}	Blank -21		Blank -75 ^{Note2}	Blank -81 ^{Note4}	-PS -PS1 -PS3 -PSN -PL -PL1 -PL3 -PLN -GL ^{Note5}	-D4 -D5 ^{Note6}
		F5						
		F6 F7 F8 F9						
Base piping	HJC10 HJC10L HJC10S	A1 ^{Note1} A2 ^{Note1} A3 ^{Note1} A4 ^{Note1}	Blank -25	Blank -75 ^{Note3}	Blank -81 ^{Note4}	-PS -PS1 -PS3 -PSN -PL -PL1 -PL3 -PLN -GL ^{Note5}	-D4 -D5 ^{Note6}	
		A5 A6 A7 A8 A9						

Notes: 1. Valves with valve specifications F1, F2, F3, F4, A1, A2, A3, and A4 are for mounting on manifolds only, and cannot be used as single valve units.

2. The muffler thread for direct piping is M3X0.5 and the muffler cannot be used for sub-base piping.

3. When ordering the sub-base piping with muffler, always enter both -25 (sub-base) and -75 (muffler). The muffler thread for sub-base piping is 10-32 UNF and the muffler cannot be used for direct piping.

4. The locking-type manual override is not available in the quick response type HJC10S.

5. The grommet type is not available in the low current type HJC10L and quick response type HJC10S.

6. The DC12V specification is not available in the low current type HJC10L and quick response type HJC10S.

HJC Series Manifold Order Codes

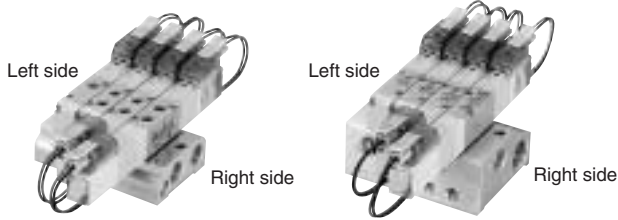

Manifold specification

F type (direct piping type)

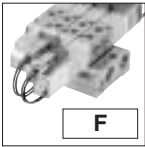

F

A type (base piping type)

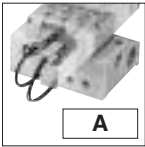

A

Mounting type

Direct mounting

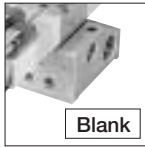

Blank

With DIN rail mounting bracket (A type manifold only)



-DN

Mounting bracket is included.

Valve specification

- F1, A1: 2-port normally closed (NC)
- F2, A2: 2-port normally open (NO)
- F3, A3: 3-port normally closed (NC)
- F4, A4: 3-port normally open (NO)
- F5, A5: 5-port 2-position, single solenoid
- F6, A6: 5-port 2-position, double solenoid
- F7, A7: 3-position, closed center
- F8, A8: 3-position, exhaust center
- F9, A9: 3-position, pressure center

Manual override

Non-locking type

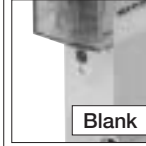

Blank

Locking type^{Note2}

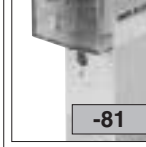

-81

Wiring specification

S type plug connector
Lead wire 300mm

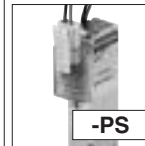

-PS

L type plug connector
Lead wire 300mm

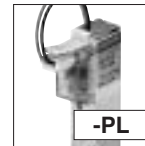

-PL

S type plug connector
Lead wire 1000mm



-PS1

L type plug connector
Lead wire 1000mm



-PL1

S type plug connector
Lead wire 3000mm



-PS3

L type plug connector
Lead wire 3000mm



-PL3

S type plug connector
Without connector ass'y



-PSN

L type plug connector
Without connector ass'y



-PLN

Grommet type^{Note3}
Lead wire 300mm
(moisture proof specification)

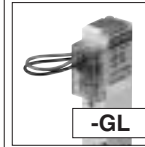

-GL

300mm = [11.8in.]
1000mm = [39in.]
3000mm = [118in.]

Voltage

-D4
DC24V

-D5
DC12V^{Note4}

Model

HJC10

Standard type

HJC10L

Low current type

HJC10S

Quick response type

Model	Number of units	Manifold specification	Mounting type	Station	Model	Valve specification	Manual override	Wiring specification	Voltage
Manifold model				Mounting valve model					

F type manifold (direct piping type)	HJCM	2 . . . 20	F		stn.1 . . . stn.□ Note1	HJC10 HJC10L HJC10S	F1 F2 F3 F4 F5 F6 F7 F8 F9	Blank -81 ^{Note2}	-PS -PS1 -PS3 -PSN -PL -PL1 -PL3 -PLN -GL ^{Note3}	-D4 -D5 ^{Note4}
			JCBP (for block-off plate)							
A type manifold (base piping type)			A	Blank -DN	stn.1 . . . stn.□ Note1	HJC10 HJC10L HJC10S	A1 A2 A3 A4 A5 A6 A7 A8 A9	Blank -81 ^{Note2}	-PS -PS1 -PS3 -PSN -PL -PL1 -PL3 -PLN -GL ^{Note3}	-D4 -D5 ^{Note4}
JCBP (for block-off plate)										

- Notes: 1. The valve mounting location is from the left side of the manifold.
 2. The locking-type manual override is not available in the quick response type HJC10S.
 3. The grommet type is not available in the low current type HJC10L and quick response type HJC10S.
 4. The DC12V specification is not available in the low current type HJC10L and quick response type HJC10S.

HJC Series Additional Parts Order Codes

Block-off plate (block-off plate and 2 mounting screws)
JCBP

Connector-related

EAZ - []

Connector specification

- P** : Connector, lead wire length 300mm [11.8in.]
- P1** : Connector, lead wire length 1000mm [39in.]
- P3** : Connector, lead wire length 3000mm [118in.]
- PN** : Connector, without lead wire (contacts included)

DIN rail mounting bracket (with screws)
JCZ -DN



Common connector assembly

EAZ - []

Connector specification

- PA** : Positive common A type, connector, lead wire length 300mm [11.8in.]
- PA1** : Positive common A type, connector, lead wire length 1000mm [39in.]
- PA3** : Positive common A type, connector, lead wire length 3000mm [118in.]
- PB** : Positive common B type, connector, lead wire length 300mm [11.8in.]
- PB1** : Positive common B type, connector, lead wire length 1000mm [39in.]
- PB3** : Positive common B type, connector, lead wire length 3000mm [118in.]
- PC** : Positive common C type, connector, lead wire length 300mm [11.8in.]
- PC1** : Positive common C type, connector, lead wire length 1000mm [39in.]
- PC3** : Positive common C type, connector, lead wire length 3000mm [118in.]
- CPN** : Positive common, connector, without lead wire (short bar and contacts included)

A type: EAZ-PA[]*



B type: EAZ-PB[]*

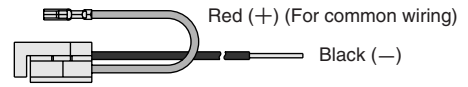

C type: EAZ-PC[]*

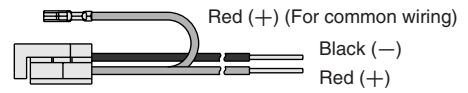

※Lead wire length **Blank** : 300mm [11.8in.]
 1 : 1000mm [39in.]
 3 : 3000mm [118in.]

Application example

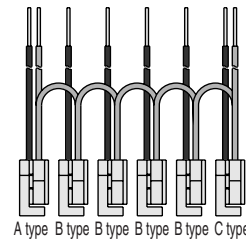

Dimensions of HJC Series Single Valve Unit (mm)

5-port, single solenoid
HJC10□F5-PL

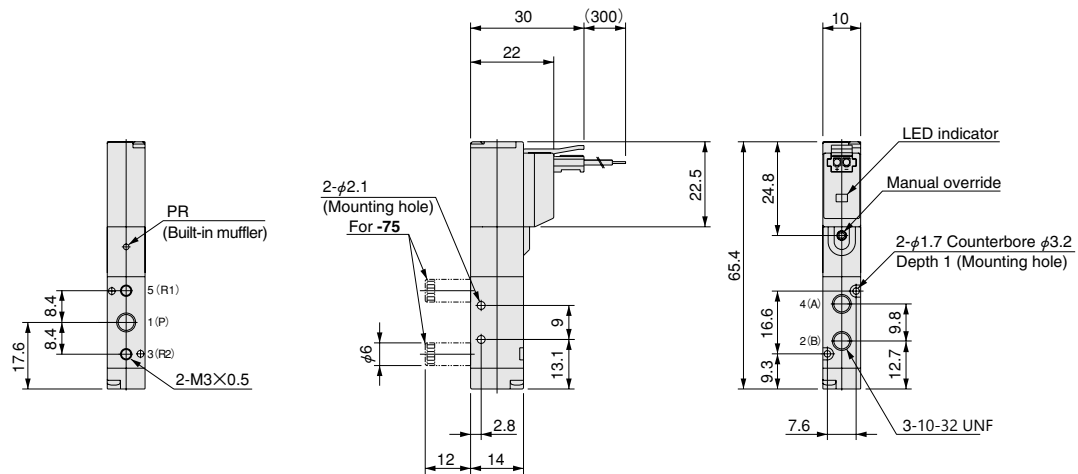

5-port, single solenoid (with sub-base)
HJC10□A5-25-PL

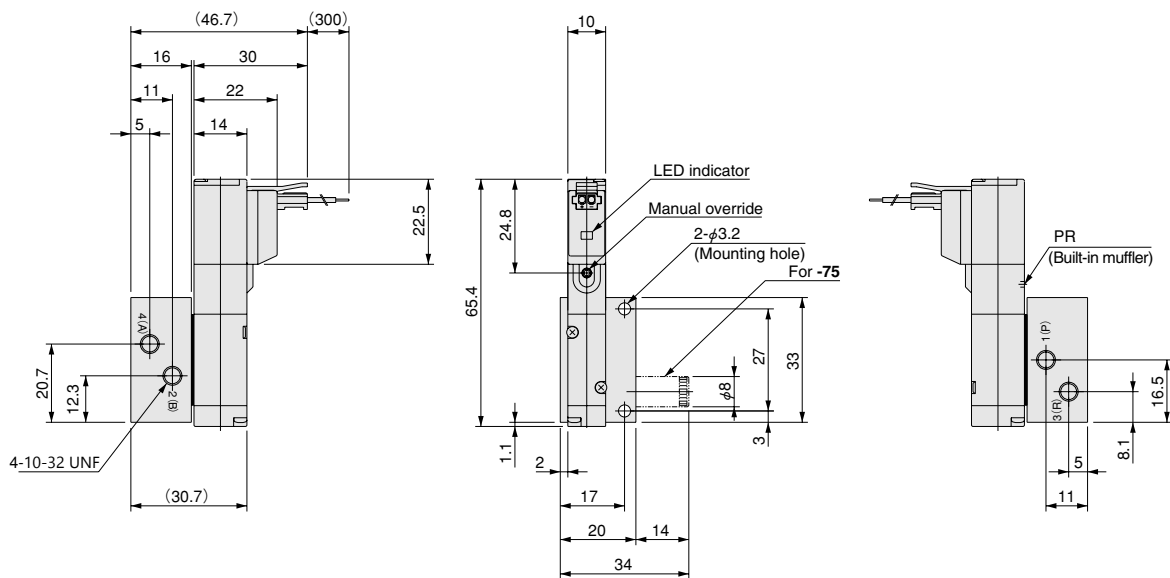

Options

- Mounting base: **-21**
- Locking type manual override: **-81**
- Grommet: **-GL**
- S type plug connector: **-PS**

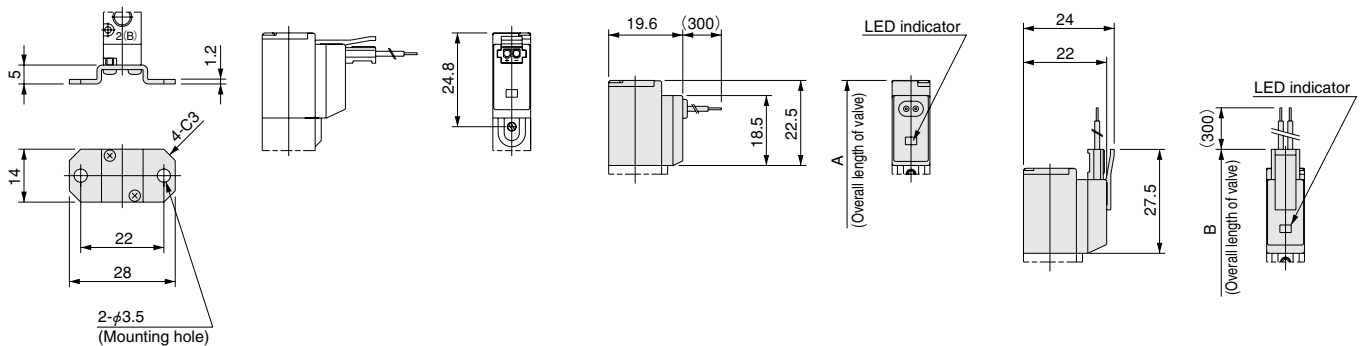

Model	Code	A	B	Remark
HJC10F5, HJC10A5		65.4	70.4	Overall length to the end of the valve
HJC10LF5, HJC10LA5, HJC10SF5, HJC10SA5		-	70.4	

Dimensions of HJC Series Single Valve Unit (mm)

5-port, double solenoid
HJC10□F6-PL

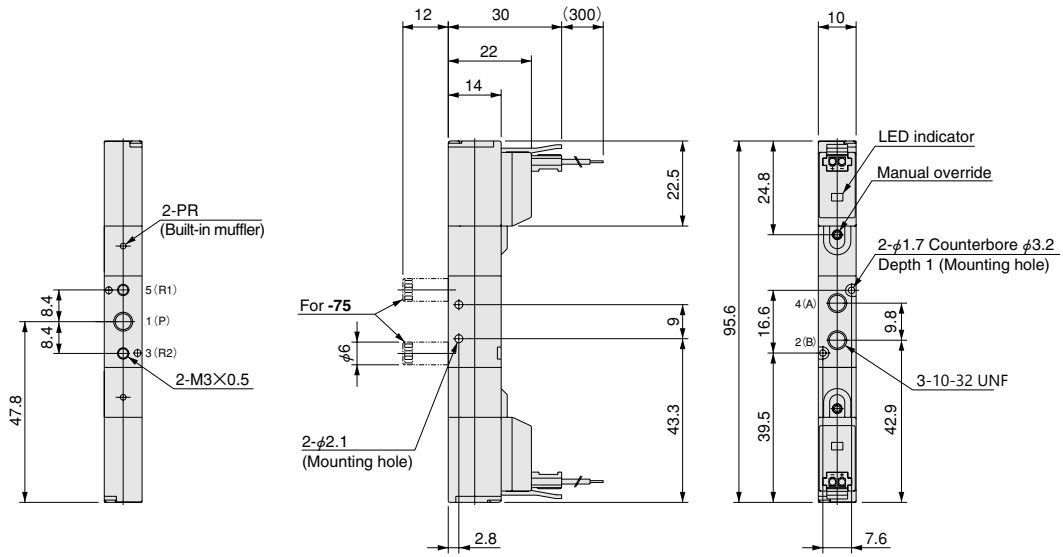

5-port, double solenoid (with sub-base)
HJC10□A6-25-PL

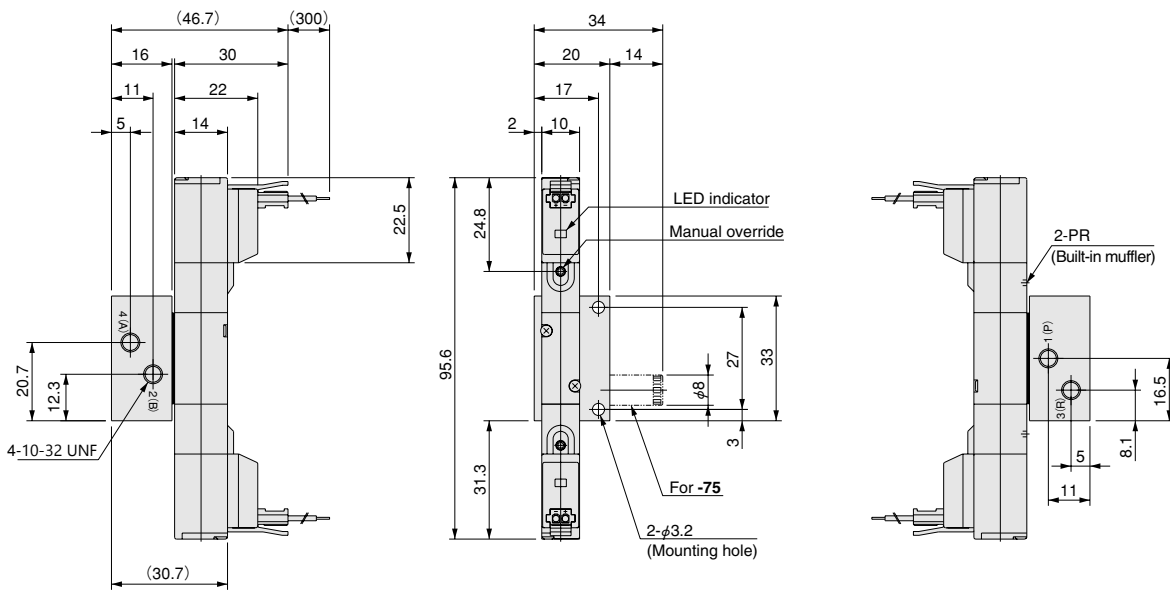

Dimensions of HJC Series Single Valve Unit (mm)

5-port, 3-position

- HJC10□F7-PL
- HJC10□F8-PL
- HJC10□F9-PL

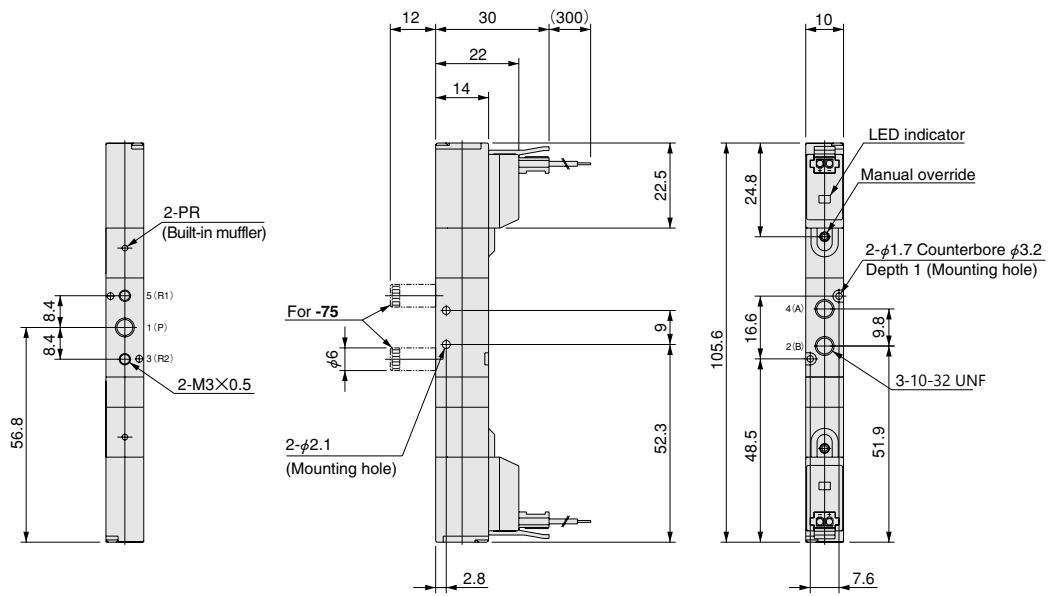

5-port, 3-position (with sub-base)

- HJC10□A7-25-PL
- HJC10□A8-25-PL
- HJC10□A9-25-PL

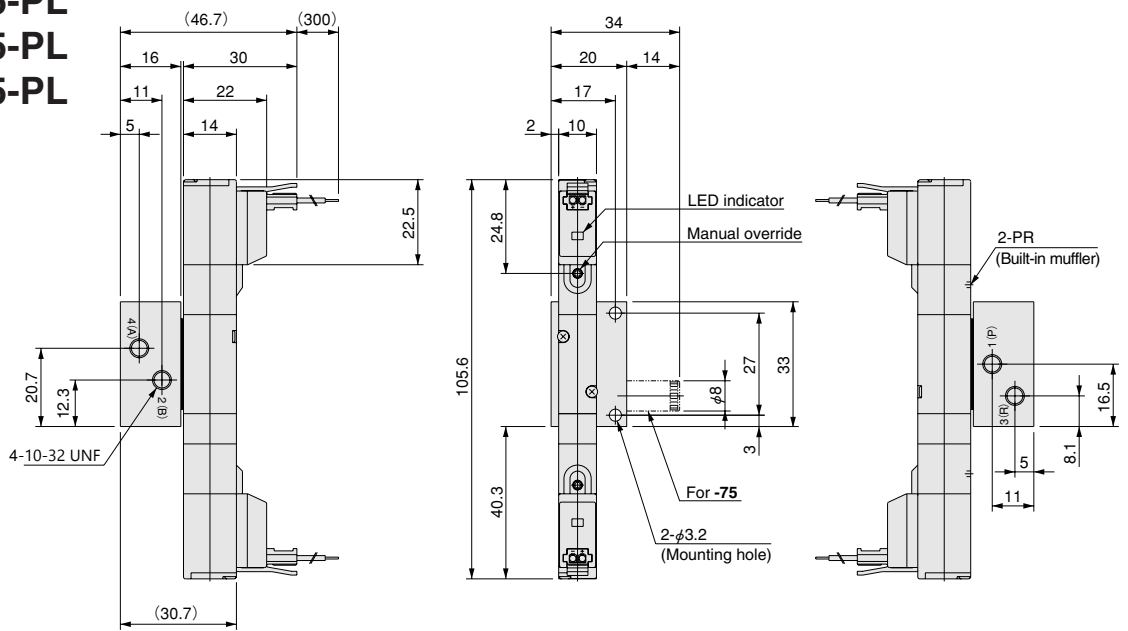

Options

● Locking type manual override: **-81**

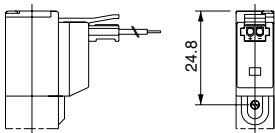

● Grommet: **-GL**

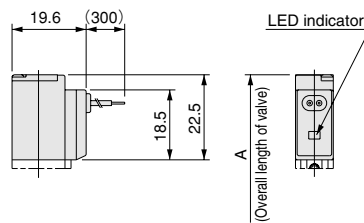

● S type plug connector: **-PS**

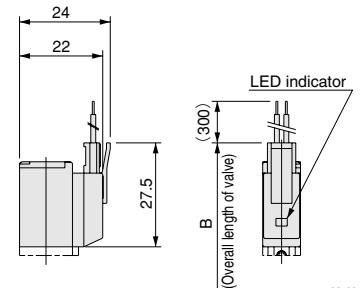

Model	Code	A	B	Remark
HJC10F6, HJC10A6		95.6	105.6	Overall length to the opposite end of the solenoid
HJC10F7~HJC10F9, HJC10A7~HJC10A9		105.6	115.6	
HJC10LF6, HJC10LA6, HJC10SF6, HJC10SA6		—	105.6	
HJC10LF7~HJC10LF9, HJC10LA7~HJC10LA9		—	115.6	
HJC10SF7~HJC10SF9, HJC10SA7~HJC10SA9		—	115.6	

Dimensions of HJC Series Manifold (mm)

Manifold for combination mounting of 2, 3, 5-port valves

HJCM□F (direct piping type)

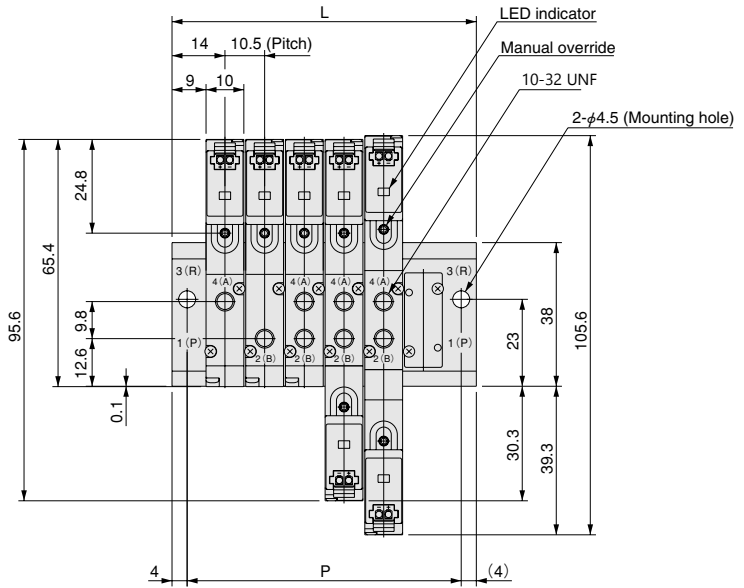
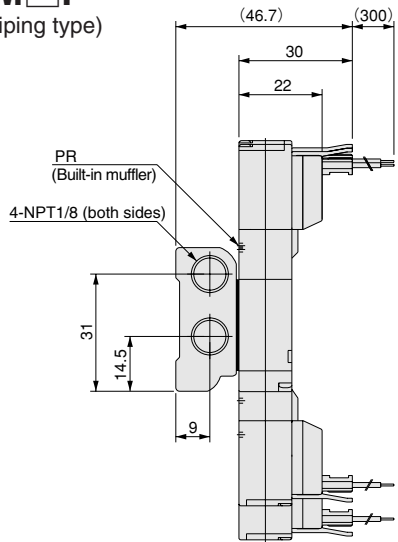

[Installation example]

HJCM6F

- stn.1 HJC10F3-PL-D4
- stn.2 HJC10F4-PL-D4
- stn.3 HJC10F5-PL-D4
- stn.4 HJC10F6-PL-D4
- stn.5 HJC10F7-PL-D4
- stn.6 HJCBP

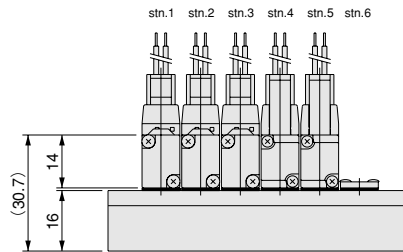

Unit dimensions

Number of units	L	P
2	38.5	30.5
3	49.0	41.0
4	59.5	51.5
5	70.0	62.0
6	80.5	72.5
7	91.0	83.0
8	101.5	93.5
9	112.0	104.0
10	122.5	114.5
11	133.0	125.0
12	143.5	135.5
13	154.0	146.0
14	164.5	156.5
15	175.0	167.0
16	185.5	177.5
17	196.0	188.0
18	206.5	198.5
19	217.0	209.0
20	227.5	219.5

Dimensions of HJC Series Manifold (mm)

Manifold for combination mounting of 2, 3, 5-port valves

HJCM□A (base piping type)

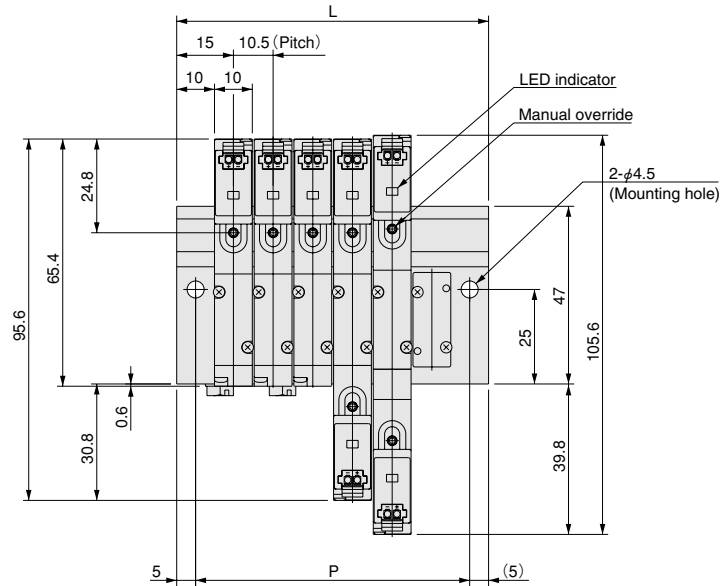
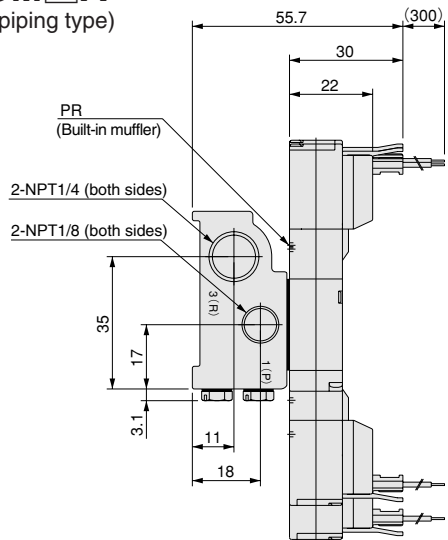

[Installation example]

HJCM6A

- stn.1 HJC10A3-PL-D4
- stn.2 HJC10A4-PL-D4
- stn.3 HJC10A5-PL-D4
- stn.4 HJC10A6-PL-D4
- stn.5 HJC10A7-PL-D4
- stn.6 HJCBP

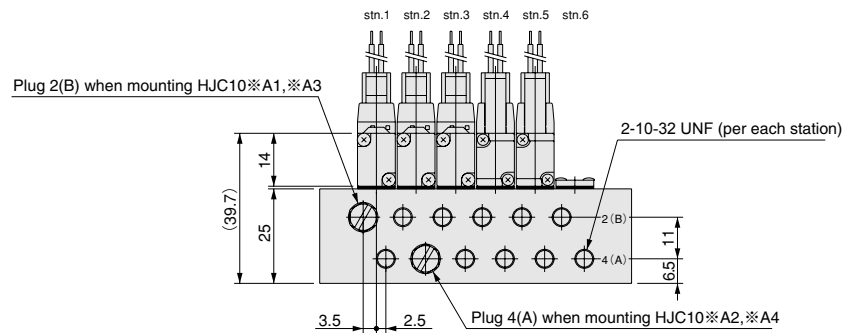

●DIN rail mounting bracket (-DN)

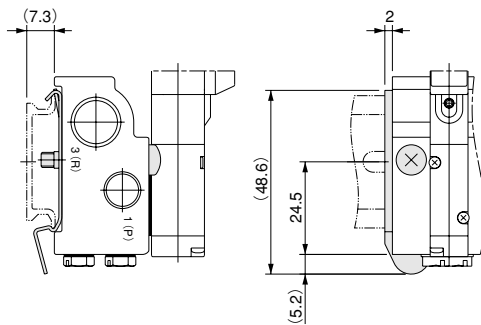

Unit dimensions

Number of units	L	P
2	40.5	30.5
3	51.0	41.0
4	61.5	51.5
5	72.0	62.0
6	82.5	72.5
7	93.0	83.0
8	103.5	93.5
9	114.0	104.0
10	124.5	114.5
11	135.0	125.0
12	145.5	135.5
13	156.0	146.0
14	166.5	156.5
15	177.0	167.0
16	187.5	177.5
17	198.0	188.0
18	208.5	198.5
19	219.0	209.0
20	229.5	219.5

Solenoid Valves HJE Series

(2, 3, 5-port pilot type solenoid valves)

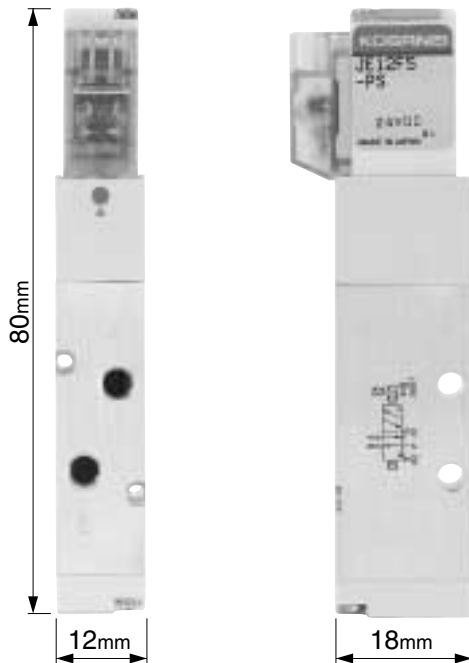

- **Space Saving—Thin and compact size**

Valve width: 12mm [0.472in.]
Valve length: 80mm [3.150in.]

- **Flow—Large flow rate with a compact body**

Sonic conductance C: 1.9dm³/(s·bar)
(Effective area: 9.5mm² [Cv: 0.53])
Optimum for operating up to ϕ 80 bore size cylinders.

- **Response—Quick response**

Response time: When ON, 6ms or below
When OFF, 10ms or below
(for quick response type single solenoid)

- **Power—Lower power consumption**

Standard type: 0.55W, Low current type: 0.15W

- **Safety—Configured to prevent erroneous operations**

Lever type manual override with erroneous operation prevention mechanism improves safety.

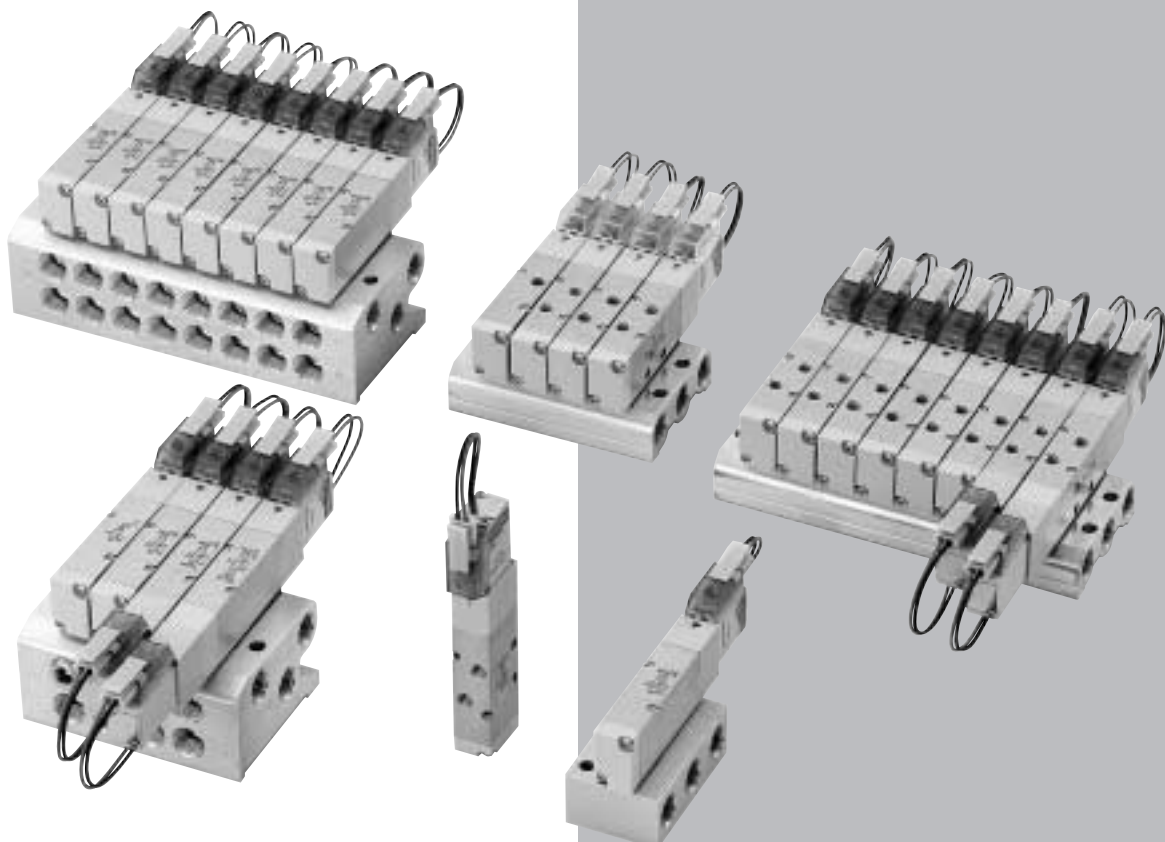

HJE SERIES SPECIFICATIONS

Specifications

Basic Models and Functions

Basic model	For direct piping, F type manifolds	HJE12□F1 ^{Note} HJE12□F2 ^{Note} HJE12□F3 ^{Note} HJE12□F4 ^{Note}	HJE12□F5	HJE12□F6	HJE12□F7 HJE12□F8 HJE12□F9
	For base piping, A type manifolds	HJE12□A1 ^{Note} HJE12□A2 ^{Note} HJE12□A3 ^{Note} HJE12□A4 ^{Note}	HJE12□A5	HJE12□A6	HJE12□A7 HJE12□A8 HJE12□A9
Item					
Number of positions		2 positions			3 positions
Number of ports		2, 3 ports	5 ports		
Valve function		Single solenoid NC, NO	Single solenoid	Double solenoid	Closed center, Exhaust center, Pressure center

Remark: For the optional specifications and order codes, see p.253.

Note: Valves with valve specifications F1, F2, F3, F4, A1, A2, A3, and A4 are for mounting on manifolds only, and cannot be used as single valve units.

Specifications

Basic model	For direct piping, F type manifolds	HJE12□F1 HJE12□F2 HJE12□F3 HJE12□F4	HJE12□F5	HJE12□F6	HJE12□F7 HJE12□F8 HJE12□F9
	For base piping, A type manifolds	HJE12□A1 HJE12□A2 HJE12□A3 HJE12□A4	HJE12□A5	HJE12□A6	HJE12□A7 HJE12□A8 HJE12□A9
Item					
Media		Air			
Operation type		Internal pilot type			
Flow rate characteristics ^{Note 1} Sonic conductance C dm ³ /(s · bar)		Base piping (A type): 1.9			
Port size ^{Note 2}		Direct piping (F type): 10-32 UNF, Base piping (A type): NPT1/8			
Lubrication		Not required			
Operating pressure range MPa {kgf/cm ² }[psi.]		0.2~0.7 {2~7.1} [29~102]			
Proof pressure MPa {kgf/cm ² }[psi.]		1.05 {10.7} [152]			
Response time ^{Note 3} ON/OFF	ms	Standard type	12/28 or below	20 or below	12/30 or below
		Low current type (L)	12/60 or below	20 or below	12/60 or below
		Quick response type (S)	6/10 or below	8 or below	6/10 or below
Maximum operating frequency	Hz	Standard type	5		
		Low current type (L)	2		
		Quick response type (S)	10		
Minimum time to energize for self holding ^{Note 4}		ms	—	50	—
Operating temperature range (atmosphere and media)		°C [°F] 5~50 [41~122]			
Shock resistance		m/s ² {G}	1373.0 {140} (Axial direction 294.2 {30})	1373.0 {140} (Axial direction 245.0 {25})	
Mounting direction		Any			

Notes: 1. For details, see the flow rate characteristics on p.250.

2. For details, see the port size on p.251.

3. Values when air pressure is 0.5MPa [73psi.]. The values for the 3-position valves are the switching time from the neutral position.

4. For double solenoid valve.

Solenoid Specifications

Item	Rated voltage	DC12V (Standard type)		DC24V (Standard type)		DC24V (Low current type)		DC24V (Quick response type)	
Operating voltage range		V		10.8~13.2 (12±10%)	21.6~26.4 (24±10%)	21.6~26.4 (24±10%)	21.6~26.4 (24±10%)	21.6~26.4 (24±10%)	21.6~26.4 (24±10%)
Standard type	Current (when rated voltage is applied)	mA (r.m.s)		46	23	—	—	—	—
	Power consumption	W		0.55	0.55	—	—	—	—
Low current type Quick response type	Current (when rated voltage is applied)	Starting	mA	—	—	23	—	125	—
		Holding	mA	—	—	6.3	—	46	—
	Power consumption	Starting	W	—	—	0.55	—	3	—
		Holding	W	—	—	0.15	—	1.1	—
Start-up time (standard time)		ms		—	—	200 or below	—	30 or below	—
Allowable leakage current		mA		2	1	0.5	—	4	—
Insulation resistance		MΩ		Over 100 (value at DC500V megger)					
Color of LED indicator		Red							
Surge suppression (as standard)		Flywheel diode							

Flow Rate Characteristics

The test method for flow rate characteristics conforms to JIS B 8390:2000 (test method for pneumatic equipment — equipment for compressible fluids — flow rate characteristics).

● When used as a single unit (with fittings)

Basic model		Flow path	Sonic conductance C dm ³ /(s·bar)	Critical pressure ratio b	Effective area S ^{Note 5} mm ² [Cv]	
Direct piping ^{Note 1}	HJE12□F5	1 (P) → 4 (A)	0.81	0.55	4.05 [0.225]	
		1 (P) → 2 (B)	0.81	0.54	4.05 [0.225]	
		4 (A) → 5 (R1)	0.75	0.44	3.75 [0.208]	
	HJE12□F6	2 (B) → 3 (R2)	0.76	0.43	3.80 [0.211]	
		HJE12□F7	1 (P) → 4 (A)	0.80	0.51	4.00 [0.222]
			1 (P) → 2 (B)	0.80	0.52	4.00 [0.222]
	HJE12□F8	4 (A) → 5 (R1)	0.71	0.41	3.55 [0.197]	
	HJE12□F9	2 (B) → 3 (R2)	0.72	0.43	3.60 [0.200]	
	Base piping ^{Note 2} (with sub-base)	HJE12□A5	1 (P) → 4 (A)	1.91	0.19	9.55 [0.531]
1 (P) → 2 (B)			1.93	0.18	9.65 [0.536]	
4 (A) → 5 (R1)			1.90	0.15	9.50 [0.528]	
HJE12□A6		2 (B) → 3 (R2)	1.90	0.12	9.50 [0.528]	
		HJE12□A7	1 (P) → 4 (A)	1.42	0.20	7.10 [0.394]
			1 (P) → 2 (B)	1.49	0.21	7.45 [0.414]
HJE12□A8		4 (A) → 5 (R1)	1.37	0.18	6.85 [0.381]	
HJE12□A9		2 (B) → 3 (R2)	1.28	0.14	6.40 [0.356]	

● When mounted on a manifold (with fittings)

Basic model		Flow path	Sonic conductance C dm ³ /(s·bar)	Critical pressure ratio b	Effective area S ^{Note 5} mm ² [Cv]	
F type manifold ^{Note 3} (direct piping type)	HJE12□F1	1 (P) → 4 (A)	0.88	0.64	4.40 [0.244]	
		HJE12□F2	1 (P) → 2 (B)	0.88	0.63	4.40 [0.244]
		HJE12□F3	4 (A) → 5 (R1)	0.90	0.20	4.50 [0.250]
	HJE12□F4	HJE12□F5	2 (B) → 3 (R2)	0.91	0.20	4.55 [0.253]
		HJE12□F6	1 (P) → 4 (A)	0.84	0.59	4.20 [0.233]
			1 (P) → 2 (B)	0.85	0.59	4.25 [0.236]
	HJE12□F7	4 (A) → 5 (R1)	0.85	0.20	4.25 [0.236]	
	HJE12□F8	2 (B) → 3 (R2)	0.85	0.21	4.25 [0.236]	
	A type manifold ^{Note 4} (base piping type)	HJE12□A1	1 (P) → 4 (A)	1.62	0.38	8.10 [0.450]
HJE12□A2			1 (P) → 2 (B)	1.63	0.38	8.15 [0.453]
HJE12□A3			4 (A) → 5 (R1)	1.82	0.10	9.10 [0.506]
HJE12□A4		HJE12□A5	2 (B) → 3 (R2)	1.77	0.18	8.85 [0.492]
		HJE12□A6	1 (P) → 4 (A)	1.34	0.40	6.70 [0.372]
			1 (P) → 2 (B)	1.37	0.24	6.85 [0.381]
HJE12□A7		4 (A) → 5 (R1)	1.34	0.08	6.70 [0.372]	
HJE12□A8		2 (B) → 3 (R2)	1.26	0.17	6.30 [0.350]	

- Notes: 1. Quick fitting TSH6-M5Ms are mounted on connection ports 1(P), 2(B), and 4(A).
 2. Quick 8mm fittings are mounted on connection ports 1(P), 2(B), and 4(A).
 3. Quick fitting TSH6-M5Ms are mounted on connection ports 2(B) and 4(A).
 4. Quick 6mm fittings are mounted on connection ports 2(B) and 4(A).
 5. Figures in effective area S are calculated based on sonic conductance C ($S=5.0 \times C$).

Base piping type
(Effective area S = 9.5mm² [Cv: 0.53])

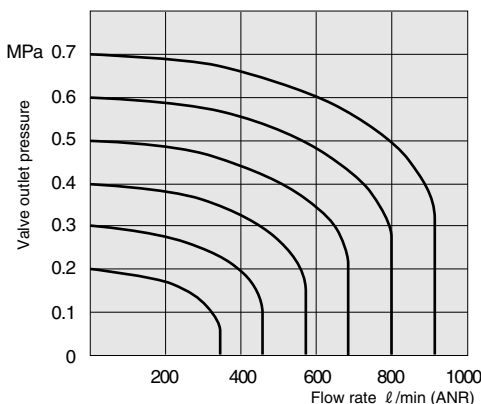

Direct piping type
(Effective area S = 4.4mm² [Cv: 0.25])

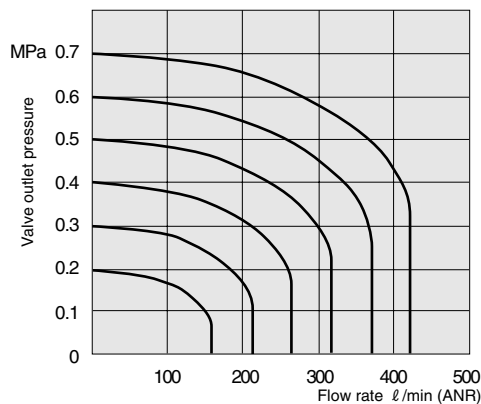

1MPa = 145psi., 1 l/min = 0.0353ft³/min

- Graphs use flow rate calculations based on the discharge method.
- Use the flow rate as a guide.

Port Size

Port specification	Port	2(B), 4(A)	1(P)	3, 5(R)
Single unit	Direct piping	10-32 UNF	10-32 UNF	10-32 UNF
	Base piping (with sub-base)	NPT1/8	NPT1/8	NPT1/8
Manifold	F type	10-32 UNF	NPT1/8	NPT1/8
	A type	NPT1/8	NPT1/8	NPT1/8

Mass

Single Valve Unit Mass

g [oz.]

Basic model	Mass	Additional mass		
		-21 (with bottom mounting base)	-22 (with side mounting base)	-25 (with sub-base)
HJE12□F1	39 [1.38]	—	—	—
HJE12□F2				
HJE12□F3				
HJE12□F4				
HJE12□F5	36 [1.27]	6 [0.21]	5 [0.18]	—
HJE12□F6	52 [1.83]			
HJE12□F7	55 [1.94]	—	5 [0.18]	—
HJE12□F8				
HJE12□F9				
HJE12□A1	39 [1.38]	—	—	—
HJE12□A2				
HJE12□A3				
HJE12□A4				
HJE12□A5	36 [1.27]	—	—	48 [1.69]
HJE12□A6	52 [1.83]			
HJE12□A7	55 [1.94]			
HJE12□A8				
HJE12□A9				

Manifold Mass

g [oz.]

Basic model	Mass calculation of each unit (n = number of units)	Block-off plate	With DIN rail mounting bracket
HJEM□F	$(13 \times n) + 17$ [(0.46 × n) + 0.60]	7 [0.25]	—
HJEM□A	$(32 \times n) + 59$ [(1.13 × n) + 2.08]		15 [0.53]

Calculation example: **HJEM8A**

stn.1~8 **HJE12A5-PS-D4**

$$(32 \times 8) + 59 + (36 \times 8) = 603\text{g} [21.27\text{oz.}]$$

5-port, 2-position

Single solenoid

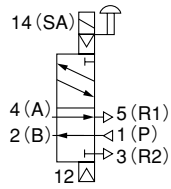

HJE12F5
De-energized

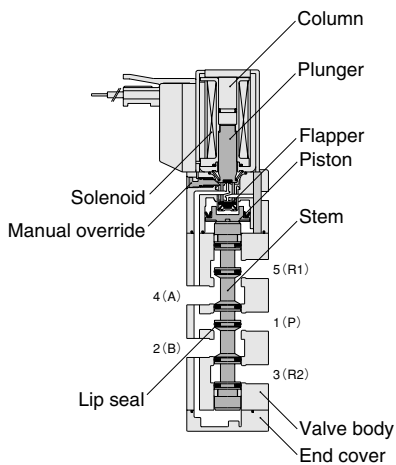

Double solenoid

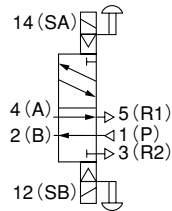

HJE12F6
[De-energized condition after energizing solenoid 12 (SB)]

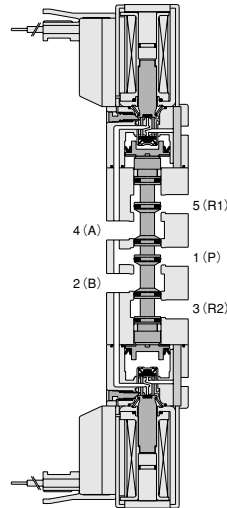

Major Parts and Materials

Parts	Materials
Body	Aluminum alloy
Stem	(anodized)
Lip seal	Synthetic rubber
Flapper	
Valve	Mounting base
	Mild steel (nickel plated)
	Sub-base
	Aluminum alloy (anodized)
	Plunger
	Magnetic stainless steel
	Column
	End cover
	Plastic
Manifold	Body
	Aluminum alloy (anodized)
	Block-off plate
	Mild steel (nickel plated)
	Seal
	Synthetic rubber

SOLENOID VALVES HJC, HJE SERIES

5-port, 3-position

[Both 14 (SA) and 12 (SB) are de-energized]

Closed center

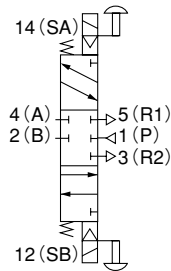

HJE12F7

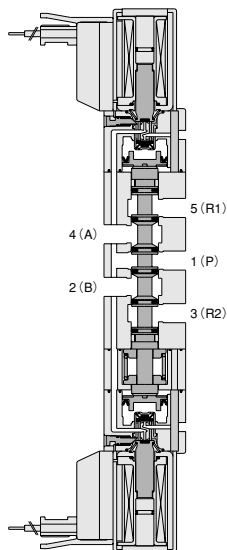

Exhaust center

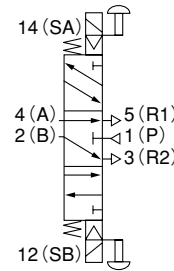

HJE12F8

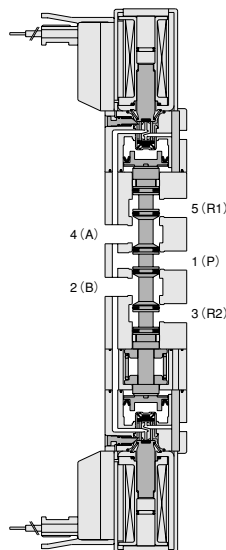

Pressure center

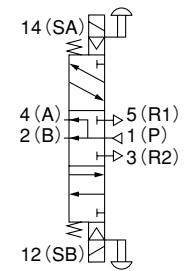

HJE12F9

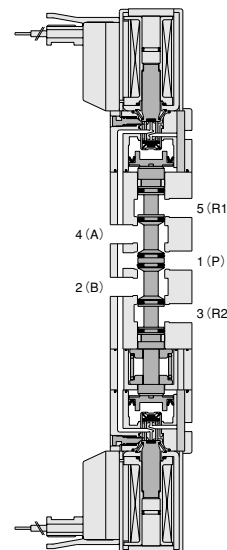

HJE Series Single Valve Unit Order Codes



Valve specification

- F1, A1: 2-port normally closed (NC)^{Note1}
- F2, A2: 2-port normally open (NO)^{Note1}
- F3, A3: 3-port normally closed (NC)^{Note1}
- F4, A4: 3-port normally open (NO)^{Note1}
- F5, A5: 5-port 2-position, single solenoid
- F6, A6: 5-port 2-position, double solenoid
- F7, A7: 3-position, closed center
- F8, A8: 3-position, exhaust center
- F9, A9: 3-position, pressure center

Model

HJE12
Standard type

HJE12L
Low current type

HJE12S
Quick response type

Mounting base

Without mounting base

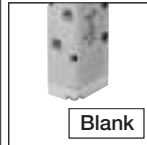

With mounting base (for bottom mounting)

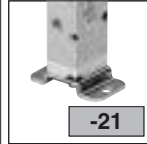

With mounting base (for side mounting)



Mounting base for side mounting is supplied with a valve.

Sub-base

Without sub-base

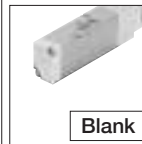

With sub-base

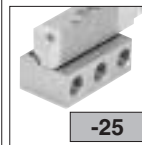

Muffler

Without muffler

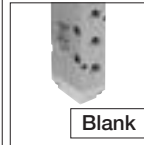

With muffler for direct piping^{Note2}

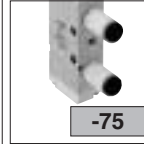

With muffler for sub-base piping^{Note3}

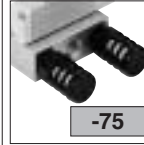

Manual override

Non-locking type



Locking type^{Note4}

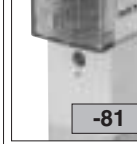

Lever type (with erroneous operation prevention mechanism)



Wiring specification

S type plug connector
Lead wire 300mm

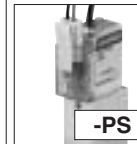

L type plug connector
Lead wire 300mm

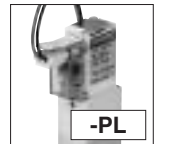

S type plug connector
Lead wire 1000mm

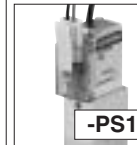

L type plug connector
Lead wire 1000mm



S type plug connector
Lead wire 3000mm



L type plug connector
Lead wire 3000mm



S type plug connector
Without connector ass'y



L type plug connector
Without connector ass'y



Grommet type^{Note5}
Lead wire 300mm
(moisture proof specification)



Voltage

-D4
DC24V

-D5
DC12V^{Note6}

300mm = [11.8in.]
1000mm = [39in.]
3000mm = [118in.]

	Model	Valve specification	Mounting base	Sub-base	Muffler	Manual override	Wiring specification	Voltage	
Direct piping	HJE12 HJE12L HJE12S	F1 ^{Note1} F2 ^{Note1} F3 ^{Note1} F4 ^{Note1}	Blank -21 -22		Blank -75 ^{Note2}	Blank -81 ^{Note4} -84	-PS -PS1 -PS3 -PSN -PL -PL1 -PL3 -PLN -GL ^{Note5}	-D4 -D5 ^{Note6}	
		F5	Blank -22						
		F6 F7 F8 F9	Blank -22						
Base piping	HJE12 HJE12L HJE12S	A1 ^{Note1} A2 ^{Note1} A3 ^{Note1} A4 ^{Note1}				Blank -81 ^{Note4} -84	-PS -PS1 -PS3 -PSN -PL -PL1 -PL3 -PLN -GL ^{Note5}	-D4 -D5 ^{Note6}	
		A5 A6 A7 A8 A9		Blank -25	Blank -75 ^{Note3}				

Notes: 1. Valves with valve specifications F1, F2, F3, F4, A1, A2, A3, and A4 are for mounting on manifolds only, and cannot be used as single valve units.

2. The muffler thread for direct piping is 10-32 UNF and the muffler cannot be used for sub-base piping.

3. When ordering the sub-base piping with muffler, always enter both -25 (sub-base) and -75 (muffler). The muffler thread for sub-base piping is NPT1/8 and the muffler cannot be used for direct piping.

4. The locking-type manual override is not available in the quick response type HJE12S.

5. The grommet type is not available in the low current type HJE12L and quick response type HJE12S.

6. The DC12V specification is not available in the low current type HJE12L and quick response type HJE12S.

HJE Series Manifold Order Codes

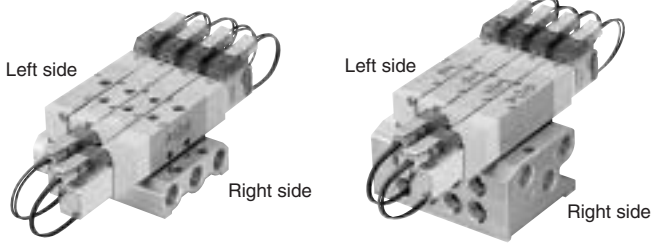

Manifold specification

F type (direct piping type)

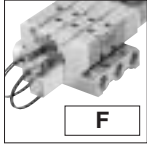

F

A type (base piping type)

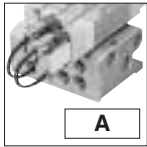

A

Mounting type

Direct mounting

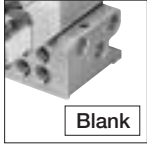

Blank

With DIN rail mounting bracket (A type manifold only)



-DN

Mounting bracket is supplied with a manifold.

Valve specification

- F1, A1:** 2-port normally closed (NC)
- F2, A2:** 2-port normally open (NO)
- F3, A3:** 3-port normally closed (NC)
- F4, A4:** 3-port normally open (NO)
- F5, A5:** 5-port 2-position, single sol.
- F6, A6:** 5-port 2-position, double sol.
- F7, A7:** 3-position, closed center
- F8, A8:** 3-position, exhaust center
- F9, A9:** 3-position, pressure center

Manual override

Non-locking type

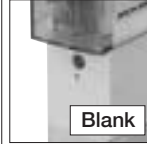

Blank

Locking type^{Note 2}



-81

Lever type (with erroneous operation prevention mechanism)



-84

Wiring specification

S type plug connector
Lead wire 300mm

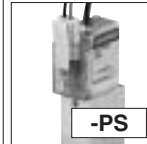

-PS

L type plug connector
Lead wire 300mm

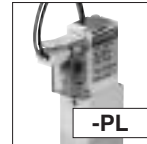

-PL

S type plug connector
Lead wire 1000mm

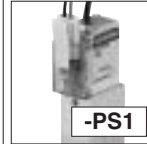

-PS1

L type plug connector
Lead wire 1000mm



-PL1

S type plug connector
Lead wire 3000mm

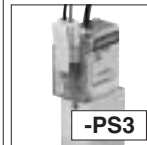

-PS3

L type plug connector
Lead wire 3000mm

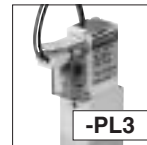

-PL3

S type plug connector
Without connector ass'y



-PSN

L type plug connector
Without connector ass'y



-PLN

Grommet type^{Note 3}
Lead wire 300mm
(moisture proof specification)



-GL

300mm = [11.8in.]
1000mm = [39in.]
3000mm = [118in.]

Model

HJE12

Standard type

HJE12L

Low current type

HJE12S

Quick response type

Model	Number of units	Manifold specification	Mounting type	Station	Model	Valve specification	Manual override	Wiring specification	Voltage
Manifold model				Mounting valve model					

F type manifold (direct piping type)	HJEM	2 . . . 20	F	stn.1 . . . stn.□ Note1	HJE12 HJE12L HJE12S	F1 F2 F3 F4 F5 F6 F7 F8 F9	Blank -81 ^{Note2} -84	-PS -PS1 -PS3 -PSN -PL -PL1 -PL3 -PLN -GL ^{Note3}	-D4 -D5 ^{Note4}
			HJEBP (for block-off plate)						
A type manifold (base piping type)	HJEM	2 . . . 20	A	stn.1 . . . stn.□ Note1	HJE12 HJE12L HJE12S	A1 A2 A3 A4 A5 A6 A7 A8 A9	Blank -81 ^{Note2} -84	-PS -PS1 -PS3 -PSN -PL -PL1 -PL3 -PLN -GL ^{Note3}	-D4 -D5 ^{Note4}
			HJEBP (for block-off plate)						

- Notes: 1. The valve mounting location is from the left side of the manifold.
 2. The locking-type manual override is not available in the quick response type HJE12S.
 3. The grommet type is not available in the low current type HJE12L and quick response type HJE12S.
 4. The DC12V specification is not available in the low current type HJE12L and quick response type HJE12S.

Dimensions of HJE Series Single Valve Unit (mm)

5-port, single solenoid HJE12□F5-PL

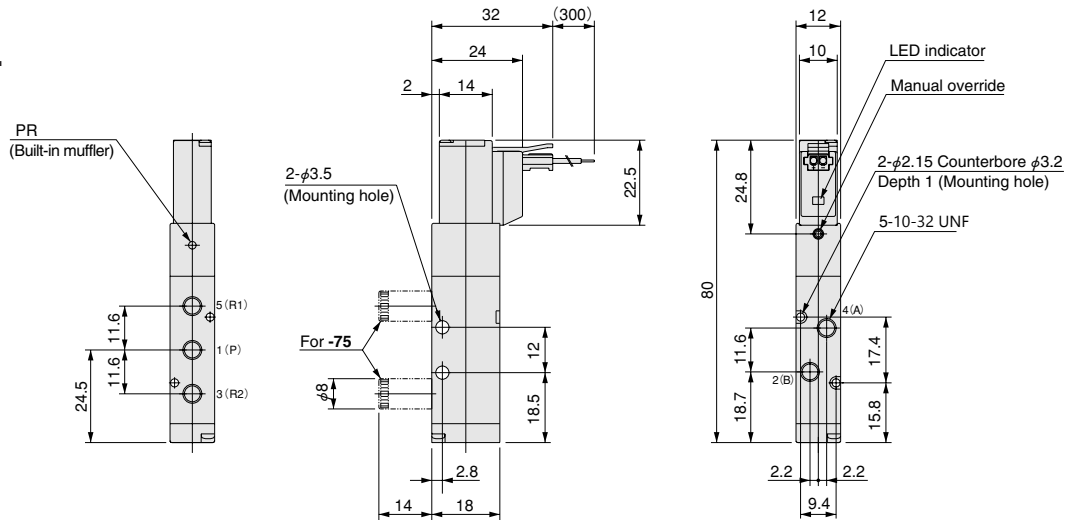

5-port, single solenoid (with sub-base) HJE12□A5-25-PL

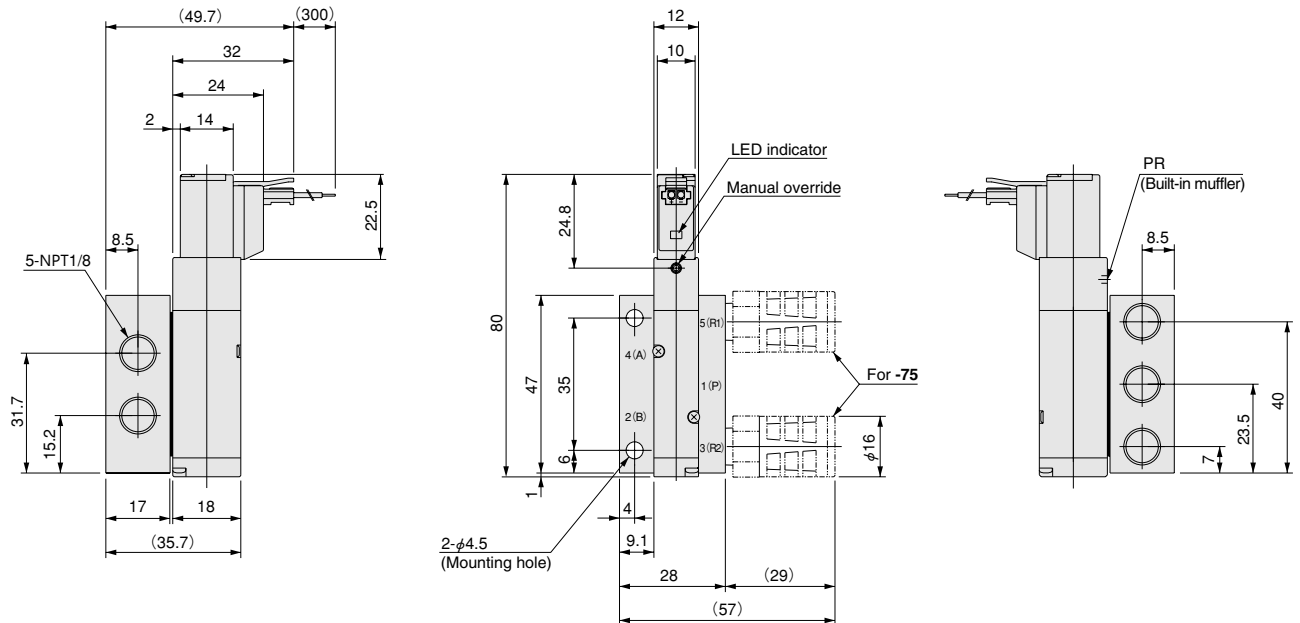

Options

● Mounting base: -21

● Mounting base: -22
(for side mounting)

● Locking type manual override: -81

● Grommet: -GL

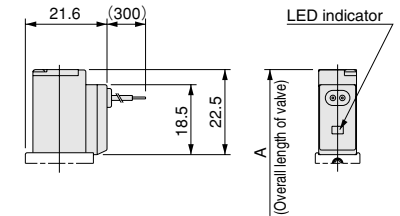
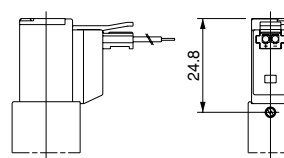
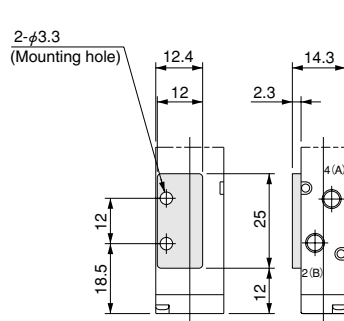
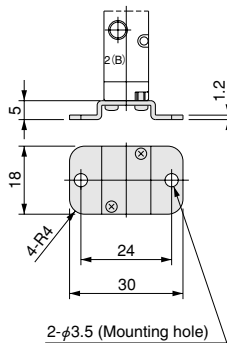

● Lever type manual override: -84

● S type plug connector: -PS

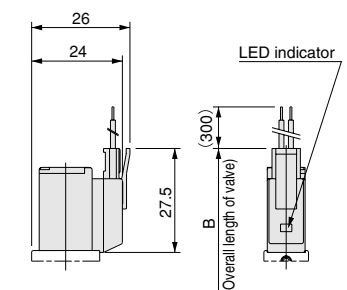
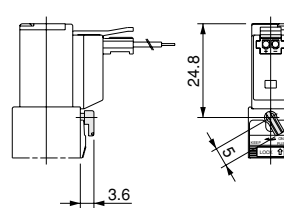

Model	Code	A	B	Remark
HJE12F5, HJE12A5		80	85	Overall length to the end of the valve
HJE12LF5, HJE12LA5, HJE12SF5, HJE12SA5		—	85	

Dimensions of HJE Series Single Valve Unit (mm)

5-port, double solenoid HJE12□F6-PL

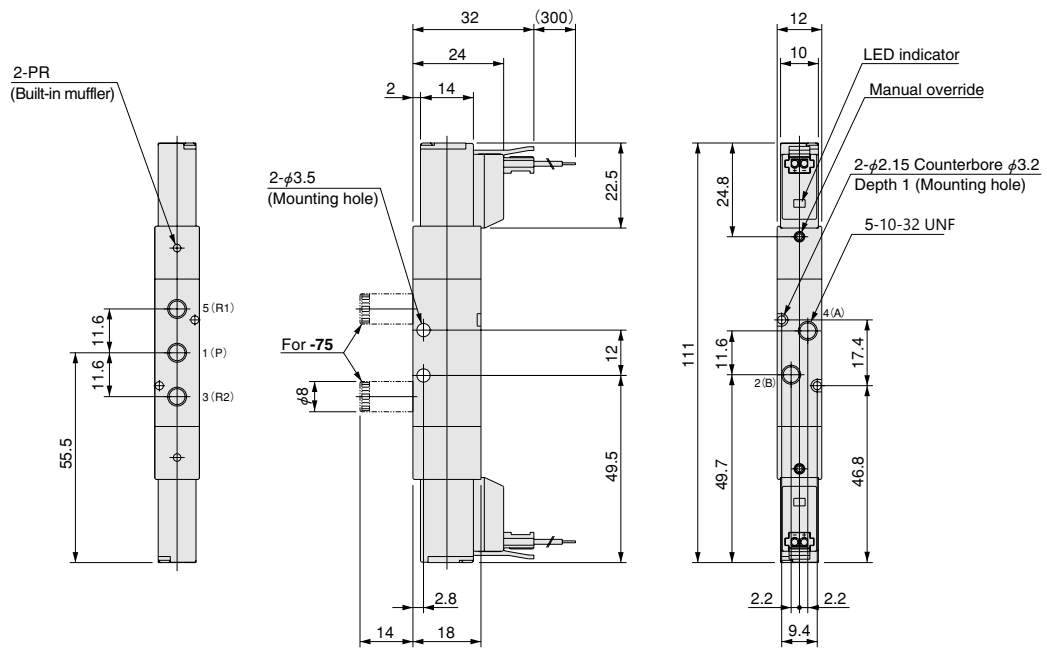

5-port, double solenoid (with sub-base) HJE12□A6-25-PL

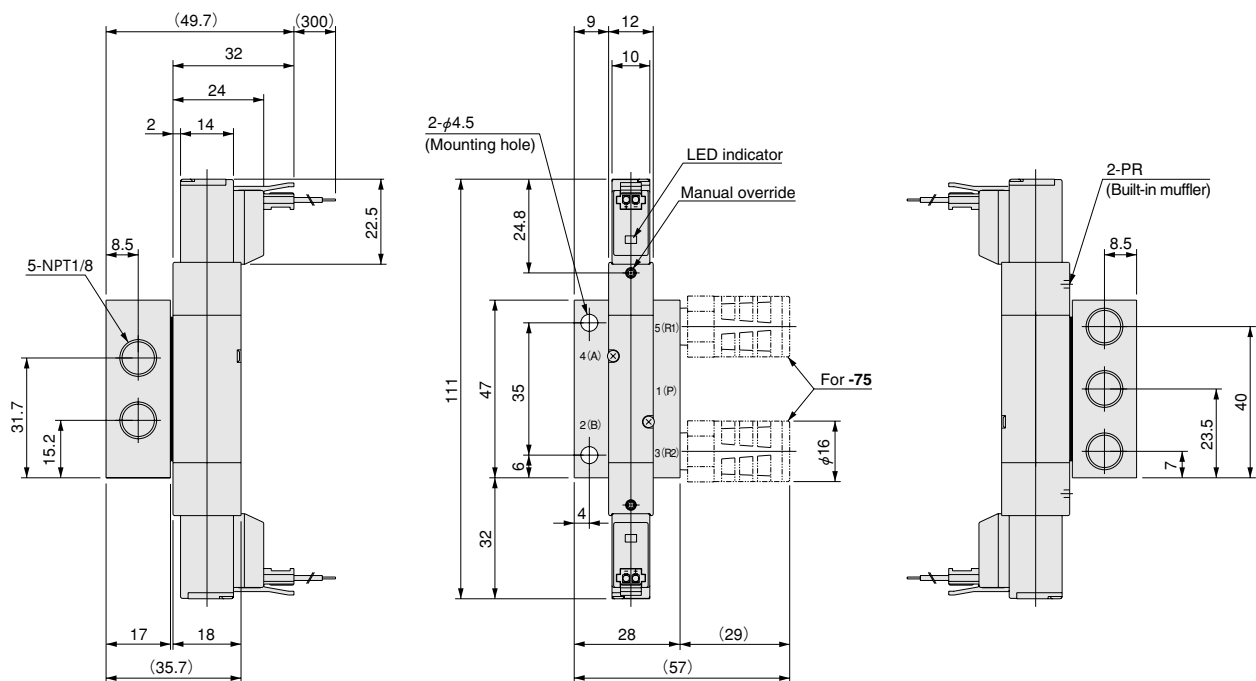

Dimensions of HJE Series Single Valve Unit (mm)

5-port, 3-position

HJE12□F7-PL
HJE12□F8-PL
HJE12□F9-PL

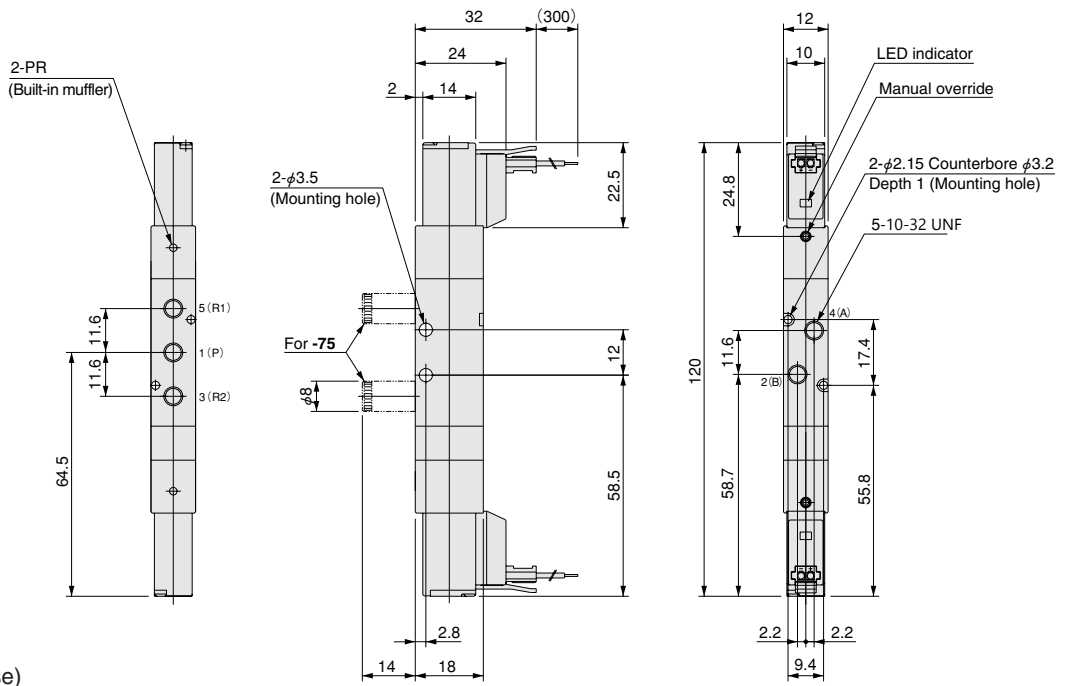

5-port, 3-position (with sub-base)

HJE12□A7-25-PL
HJE12□A8-25-PL
HJE12□A9-25-PL

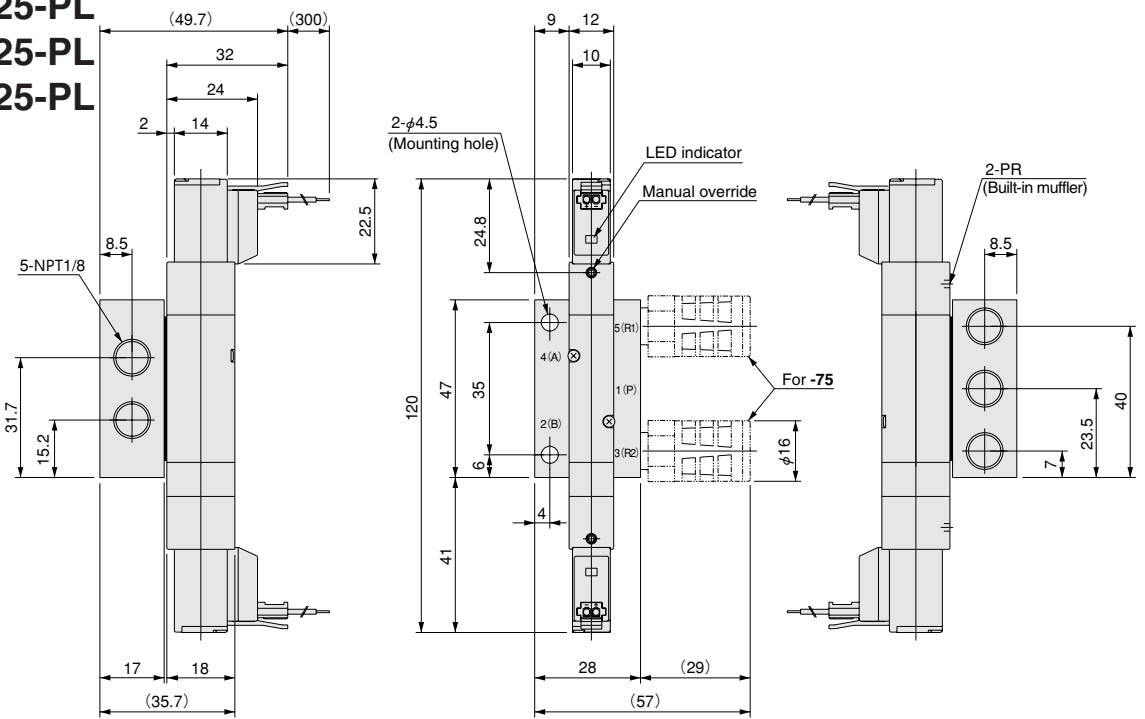

Options

● Mounting base: **-22**
(for side mounting)

● Locking type manual override: **-81**

● Lever type manual override: **-84**

● Grommet: **-GL**

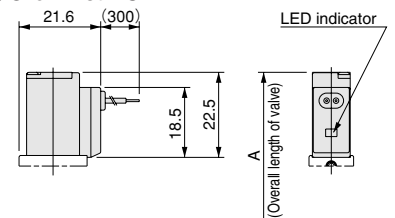
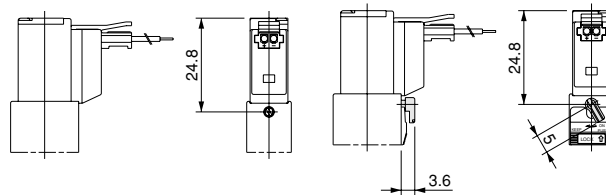
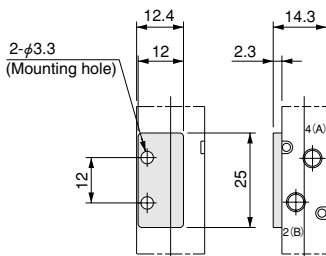

● S type plug connector: **-PS**

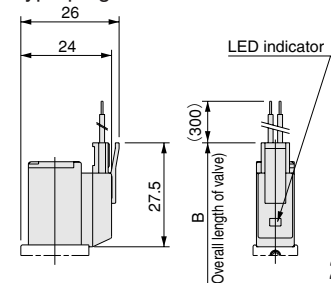

Model	Code	A	B	Remark
HJE12F6, HJE12A6		111	121	
HJE12F7~HJE12F9, HJE12A7~HJE12A9		120	130	
HJE12LF6, HJE12LA6, HJE12SF6, HJE12SA6		—	121	Overall length to the opposite end of the solenoid
HJE12LF7~HJE12LF9, HJE12LA7~HJE12LA9		—	130	
HJE12SF7~HJE12SF9, HJE12SA7~HJE12SA9		—	130	

Dimensions of HJE Series Manifold (mm)

Manifold for combination mounting of 2, 3, 5-port valves

HJEM□F

(Direct piping type)

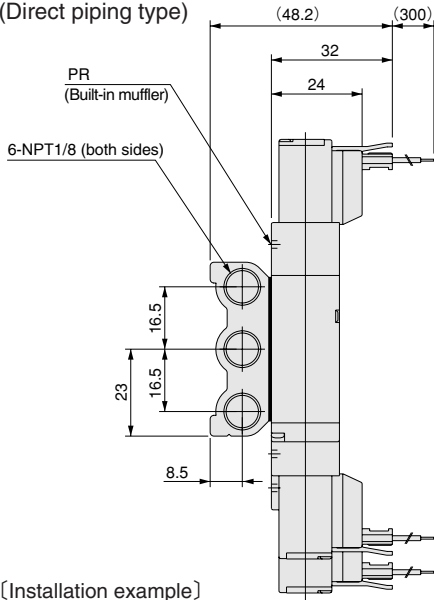

[Installation example]

HJEM6F

- stn.1 HJE12F3-PL-D4
- stn.2 HJE12F4-PL-D4
- stn.3 HJE12F5-PL-D4
- stn.4 HJE12F6-PL-D4
- stn.5 HJE12F7-PL-D4
- stn.6 HJE12F8-PL-D4

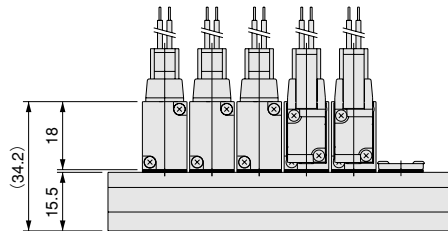
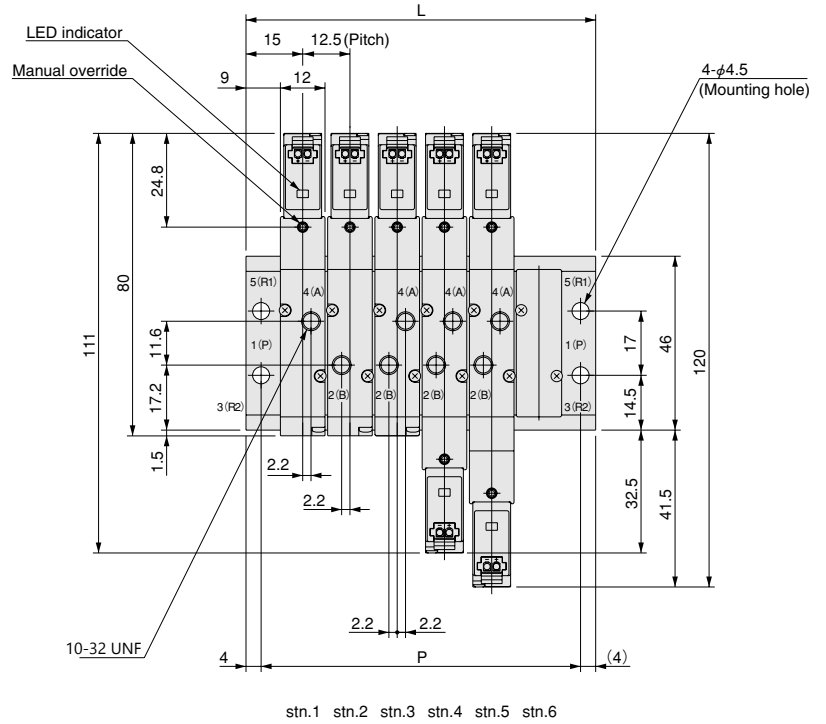

Unit dimensions

Number of units	L	P
2	42.5	34.5
3	55.0	47.0
4	67.5	59.5
5	80.0	72.0
6	92.5	84.5
7	105.0	97.0
8	117.5	109.5
9	130.0	122.0
10	142.5	134.5
11	155.0	147.0
12	167.5	159.5
13	180.0	172.0
14	192.5	184.5
15	205.0	197.0
16	217.5	209.5
17	230.0	222.0
18	242.5	234.5
19	255.0	247.0
20	267.5	259.5

Dimensions of HJE Series Manifold (mm)

Manifold for combination mounting of 2, 3, 5-port valves

HJEM□A

(Base piping type)

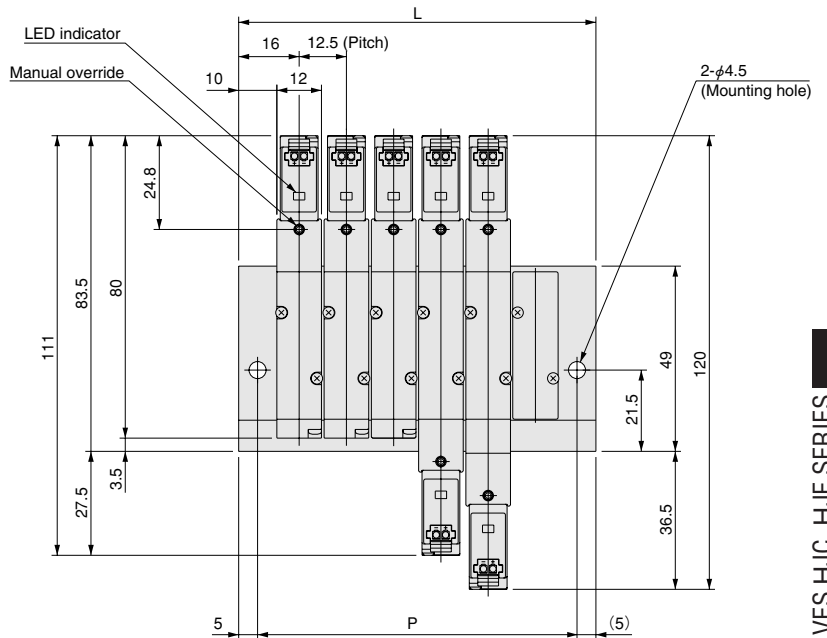
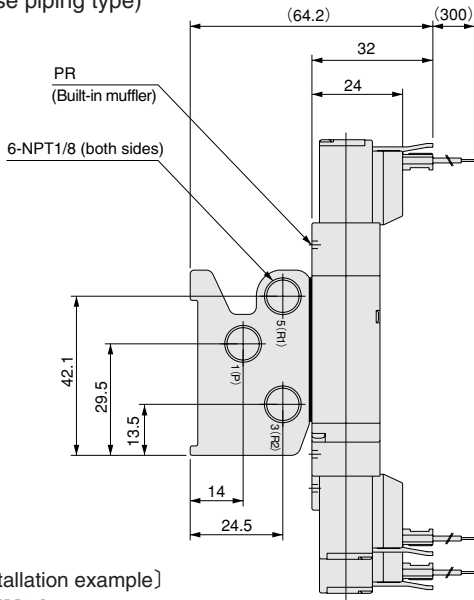

[Installation example]

HJEM6A

- stn.1 HJE12A3-PL-D4
- stn.2 HJE12A4-PL-D4
- stn.3 HJE12A5-PL-D4
- stn.4 HJE12A6-PL-D4
- stn.5 HJE12A7-PL-D4
- stn.6 HJE12A8-PL-D4

stn.1 stn.2 stn.3 stn.4 stn.5 stn.6

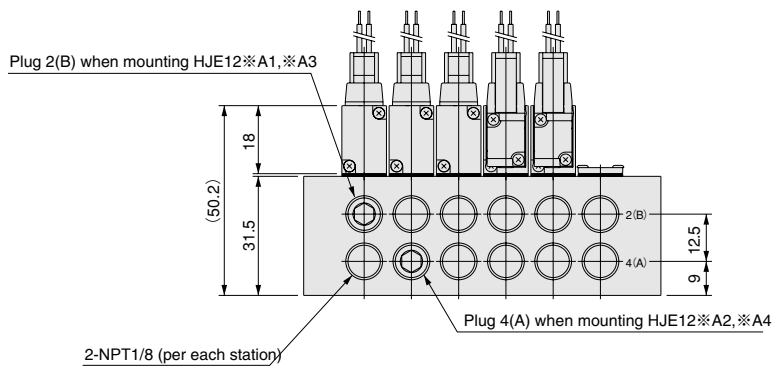

● DIN rail mounting bracket (-DN)

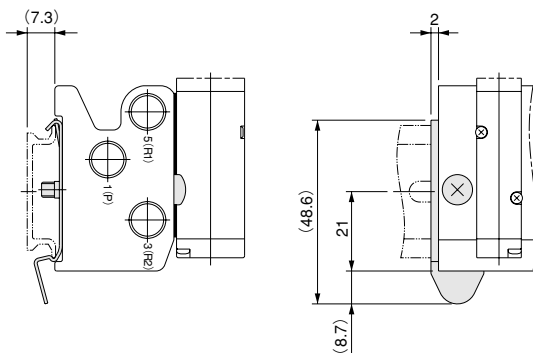





Unit dimensions

Number of units	L	P
2	44.5	34.5
3	57.0	47.0
4	69.5	59.5
5	82.0	72.0
6	94.5	84.5
7	107.0	97.0
8	119.5	109.5
9	132.0	122.0
10	144.5	134.5
11	157.0	147.0
12	169.5	159.5
13	182.0	172.0
14	194.5	184.5
15	207.0	197.0
16	219.5	209.5
17	232.0	222.0
18	244.5	234.5
19	257.0	247.0
20	269.5	259.5

Before selecting and using products, please read all the Safety Precautions carefully to ensure proper product use. The Safety Precautions shown below are to help you use the product safely and correctly, and to prevent injury or damage to assets beforehand.

Follow the Safety Precautions for: ISO4414 (Pneumatic fluid power—Recommendations for the application of equipment to transmission and control systems), JIS B 8370 (Pneumatic system regulations)

The directions are ranked according to degree of potential danger or damage: “DANGER!” “WARNING!” “CAUTION!” and “ATTENTION!”

 DANGER	Expresses situations that can be clearly predicted as dangerous. If the noted danger is not avoided, it could result in death or serious injury. It could also result in damage or destruction of assets.
 WARNING	Expresses situations that, while not immediately dangerous, could become dangerous. If the noted danger is not avoided, it could result in death or serious injury. It could also result in damage or destruction of assets.
 CAUTION	Expresses situations that, while not immediately dangerous, could become dangerous. If the noted danger is not avoided, it could result in light or semi-serious injury. It could also result in damage or destruction of assets.
 ATTENTION	While there is little chance of injury, this content refers to points that should be observed for appropriate use of the product.

■ This product was designed and manufactured as parts for use in General Industrial Machinery.

- In the selection and handling of equipment, the system designer or other person with fully adequate knowledge and experience should always read the Safety Precautions, Catalog, User’s Manual and other literature before commencing operation. Making mistakes in handling is dangerous.
- After reading the Instruction Manual, Catalog, etc., always place it where it can be easily available for reference to users of this product.
- If transferring or lending the product to another person, always attach the Instruction Manual, Catalog, etc., to the product where it is easily visible, to ensure that the new user can use the product safely and properly.
- The danger, warning, and caution items listed under these “Safety Precautions” do not cover all possible cases. Read the catalog and user’s manual carefully, and always keep safety first.

 **DANGER**

- Do not use for the purposes listed below:
 1. Medical equipment related to maintenance or management of human lives or bodies.
 2. Mechanical devices or equipment designed for the purpose of moving or transporting people.
 3. Critical safety components in mechanical devices.
 This product has not been planned or designed for purposes that require advanced stages of safety. It could cause injury to human life.
- Do not use in locations with or near dangerous substances such as flammable or ignitable substances. This product is not explosion-proof. It could ignite or burst into flames.
- When attaching the product and workpiece, always ensure that it is securely mounted in place. Dropping or falling the product or improper operation could result in injury.
- Persons who use a pacemaker, etc., should keep a distance of at least one meter [3.28ft.] away from the product. There is a possibility that the pacemaker will malfunction due to the strong magnet built into the product.
- Never attempt to remodel the product. It could result in abnormal operation leading to injury, electric shock, fire, etc.
- Never attempt inappropriate disassembly, assembly or repair of the product’s basic construction, or of its performance or functions. It could result in injury, electric shock, fire, etc.
- Do not splash water on the product. Spraying it with water, washing it, or using it underwater could result in malfunction of the product leading to injury, electric shock, fire, etc.
- While the product is in operation, avoid touching it with your hands or otherwise approaching too close. In addition, do not make any adjustments to the interior or to the attached mechanisms (manual override, connecting and disconnecting of wiring connectors, adjustment of pressure switches, or release or connection of piping tubes or plugs) while in operation. The actuator can move suddenly, possibly resulting in injury.

 **WARNING**

- Do not use the product in excess of its specification range. Such use could result in product breakdowns, function stop or damage or drastically reduce the operating life.
- Before supplying air or electricity to the device and before starting operation, always conduct a safety check of the area of machine operation. Unintentional supply of air or electricity could possibly result in electric shocks, or in injury caused by contact with moving portion.
- Do not touch the terminal and the miscellaneous switches, etc., while the device is power on. There is a possibility of electric shock and abnormal operation.
- Do not allow the product to be thrown into fire. The product could explode and/or release toxic gases.
- Do not sit on the product, place your foot on it, or place other objects on it. Accidents such as falling and tripping over could result in injury. Dropping the product may result in injury, or also damage or break the product resulting in abnormal or erratic operation, or runaway etc.
- When conducting any kind of operation for the product, such as maintenance, inspection, repair, or connect/disconnect or replacement of piping, always turn off the air supply completely and confirm that residual pressure inside the product or in piping connected to the product is zero before proceeding. In particular, be aware that residual air will still be in the air compressor or air storage tank. The actuator could abruptly move if residual air pressure remains inside the piping, causing injury.
- Before commencing normal operation, always release the lock on the locking type manual override, and confirm that the manual override is in the normal position and that the main valve is in the proper switching position, and only then commence the operation. Failure to do so could lead to erroneous operation.
- Always shut off power when performing wiring operations. Leaving the power on could result in electric shocks.
- Apply the specified voltage for the solenoid. Using the wrong voltage level will prevent the solenoid from performing its function, and could lead to breakage or burn damage of the product itself.
- Avoid scratching the cords for the sensor switch lead wires, etc. Letting the cords be subject to scratching, excessive

bending, pulling, rolling up, or being placed under heavy objects or squeezed between two objects, may result in current leaks or defective transmission that lead to fires, electric shocks, or abnormal operation.

- Do not pull out the connectors while the power is ON. Also, do not put unnecessary stress on the connector. It could result in erroneous equipment operation that could lead to personal injury, equipment breakdown, or electrical shocks, etc.
- Always check the Catalog to ensure that the product wiring and piping is done correctly. Errors in wiring and piping could lead to abnormal operation of the actuators, etc.
- In the first operation after the equipment has been idle for 48 hours or more, or has been in storage, there is a possibility that contacting parts have been stuck, resulting in equipment operation delays or sudden movements. For these first operations, always run a test operation before use to check that operating performance is normal.
- In low frequency use (more than 30 days between uses), there is a possibility that contact parts will stick, resulting in equipment operation delays or sudden movements that could lead to personal injury. Run a test operation at least once every 30 days to confirm that movement is normal.
- For double solenoid type (excluding the Tandem 3-port valve), do not apply current through both solenoids simultaneously. It is impossible in such a situation to maintain the correct valve position, and the equipment may operate in an unintended direction, leading to the possibility of equipment breakdown or personal injury.
- Do not use the solenoid valves or the wiring that controls them, near power lines where large electrical currents are flowing, or in locations subject to powerful magnetic fields or power surges. Such application could lead to unintended operation.
- The solenoid valve can generate surge voltage and electromagnetic waves when the switch is turned off, affecting the operations of surrounding equipment. Use solenoids with surge suppression, or take countermeasures in the electrical circuits for surges or electromagnetic waves.
- Do not use where ozone may be generated, such as near ocean beaches or other places subject to direct sunlight or mercury lamps. Ozone can cause rubber parts to deteriorate, which can lead to degraded performance and functions, or to equipment stoppages and functional shutdown. (Excludes items where measures against ozone have been taken.)
- Do not use any media other than shown on the specifications. Use of non-specified media could lead to functional shutdown after a short period, to sudden performance drops, or to shorter operating life.
- If mounting the solenoid valve inside a control panel, or if energizing it for long periods, provide heat radiation measures to ensure that temperatures surrounding the solenoid valve always remain within the specified temperature range. If energizing the unit for long periods, consult us.
- After finishing wiring operations, always check to ensure that no wiring connection errors exist before turning on the power.
- Do not collect the exhaust lines for air cylinders, etc. with pilot exhaust lines for solenoid valves into the same piping, etc. Interference in the exhaust could result in erratic operation.

CAUTION

- When mounting the product, leave room for adequate working space around it. Failure to ensure adequate working space will make it more difficult to conduct daily inspections or maintenance, which could eventually lead to system shutdown or damage to the product.
- For mounting or transport of heavy products, use a lift, supporting tool, or several people, to provide firm support, and proceed with due caution to ensure personal safety.
- Do not bring floppy disks or magnetic media, etc., within one meter [3.28ft.] of the product. There is the possibility that the data on the floppy disks will be destroyed due to the magnetism of the magnet.
- If leakage current is occurring in the control circuit, there is a possibility of the product performing an unintended operation. Take measures against current leaking in the control circuit, to ensure that the leakage current value does not exceed the allowed range in the product specifications.

- Do not block the product's breathing holes. Pressure changes occur due to changes in volume during operation. Blocking the breathing holes destroys the pressure balance, and could cause failure of the intended operation, equipment damage, or personal injury.
- Do not use the solenoid valve in locations subject to large electrical currents or magnetic fields. It could result in erratic operation.
- Oily materials from the compressor (excluding the oil-free compressor) can cause drastic deterioration in product performance, and even a functional shutdown. Always install a mist filter before pneumatic equipment to remove the oily component.
- The properties of the lubrication oil can change when used in dry air where dew point temperatures is lower than -20 degrees Celsius [-4°F]. It could result in degraded performance or in functional shutdown.
- Do not use the product in locations of direct sunlight (ultraviolet), in locations subject to dust, salt, or iron powder, in locations with humidity and high temperature, or in the media and/or the ambient atmospheres that include organic solvents, phosphoric ester type hydraulic oil, sulfur dioxide, chlorine gas, or acids, etc. These conditions could lead to functional shutdowns, sudden degraded performance, or shortened operating life in a brief period of time. For materials used, see Major Parts and Materials.

ATTENTION

- When considering the possibility of using this product in situations or environments not specifically noted in the Catalog or User's Manual, or in applications where safety is an important requirement, such as in an airplane facility, combustion equipment, leisure equipment, safety equipment and other places where human life or assets may be greatly affected, take adequate safety precautions such as application with enough margins for ratings and performance or fail-safe measures. Be sure to consult us with such applications.
- Always check the catalog and other reference materials for product wiring and piping.
- Install a muffler, etc. on the exhaust port. It is effective in reducing exhaust noise.
- When handling the product, wear protective gloves, safety glasses, safety boots, etc. to keep safety.
- When the product can no longer be used, or is no longer necessary, dispose of it appropriately as industrial waste.
- Pneumatic equipment can exhibit degraded performance and function over its operating life. Always conduct daily inspections of the pneumatic equipment, and confirm that all requisite system functions are satisfied, to prevent accidents from happening.
- Air leaks from the valve are not zero. For application of requiring holding pressure (including vacuum) inside the pressure vessel, consider adequate margin of capacity and holding time in design of the system.
- For inquiries about the product, consult your nearest Koganei sales office or Koganei overseas department. The address and telephone number is shown on the back cover of this catalog.

OTHERS

- Always observe the following items.
 1. When using this product in pneumatic systems, always use genuine KOGANEI parts or compatible parts (recommended parts). When conducting maintenance and repairs, always use genuine KOGANEI parts or compatible parts (recommended parts). Always observe the required methods and procedure.
 2. Do not attempt inappropriate disassembly or assembly of the product relating to basic construction, or its performance or functions.

Koganei cannot be responsible if these items are not properly observed.

General Precautions

Mounting

1. While any mounting direction is allowed, be sure to avoid strong shocks or vibrations applied directly to the body. Also, avoid strong shocks in the lateral direction when using a mounting base for installation. For the order code, see the Additional Parts item under each series.
2. Avoid using in the locations and environment listed below, as it could result in malfunction of the valve. If use in such conditions is unavoidable, always provide a cover or other adequate protective measures.
 - Location directly exposed to water drops or oil drops
 - Environment where a valve body is subject to dew condensation
 - Location directly exposed to machining chips, dust, etc
3. Install a muffler, etc. in the exhaust port to prevent dust from entering into the piping.
4. In piping connection with valves, flush the tube completely (by blowing compressed air) before piping. Intrusion of machining chips or sealing tape, rust, etc., generated during plumbing could result in air leaks and other defective operations.
5. When mounting a valve unit inside the control panels or when the operation requires long energizing periods, consider providing heat radiation measure such as ventilation.
6. Never use the valve with the 4(A) and 2(B) ports vent to atmosphere.

Media

1. Use air for the media. For the use of any other media, consult us.
2. Air used for the cylinder should be clean air that contains no deteriorated compressor oil, etc. Install an air filter (filtration of 40 μm or less) near the valve to remove collected liquid or dust. In addition, drain the air filter periodically.
3. When supply pressure is low, use piping for the 1(P) port with sufficient tube size.

Lubrication

Can be used without lubrication. When the actuator requires lubrication, use Turbine Oil Class 1 (ISO VG32) or the equivalent. Avoid using spindle oil or machine oil.

Atmosphere

The product cannot be used when the media or ambient atmosphere contains any of the substances listed below. Organic solvents, phosphate ester type hydraulic oil, sulphur dioxide, chlorine gas, or acids, etc.

How to find the flow rate

Subsonic speed flow when $P_1 + 0.1013 < 1.89 (P_2 + 0.1013)$

$$Q = 226S \sqrt{\Delta P (P_2 + 0.1013)}$$

Sonic speed flow when $P_1 + 0.1013 \geq 1.89 (P_2 + 0.1013)$

$$Q = 113S (P_1 + 0.1013)$$

Q: Air flow rate [ℓ/min (ANR)]

S: Effective area [mm²]

ΔP: Pressure drop $P_1 - P_2$ [MPa]

P₁: Upstream pressure [MPa]

P₂: Downstream pressure [MPa]

※ Corrections for variances in air temperature
Multiply the flow rate calculated in the formula above by the coefficients in the table below.

Air temperature °C [°F]	-20 [-4]	-10 [14]	0 [32]	10 [50]	30 [86]	40 [104]	50 [122]	60 [140]
Correction coefficient	1.08	1.06	1.04	1.02	0.98	0.97	0.95	0.94

Piping

Since the 1(P) and exhaust ports are on both ends of the manifold, piping direction can be selected depending on the application (excluding some models). At shipping, plugs are temporarily screwed in ports at one end, but are not firmly tightened. Regardless of which end piping is connected, always remove the plugs, use sealing tape or apply other sealing agent, and securely tighten the plugs into the unused ports.

1. Sealing tape wrapping method

- ① Before piping, use air blowing (flushing) or cleaning to eliminate any machining chips, cutting oil, or dust, etc., remaining inside the pipes.
- ② When screwing in piping or fittings, caution should be taken to avoid letting machining chips or sealing materials from entering into the valves. When using sealing tape, wrap it so that 1.5~2 screw threads remain.

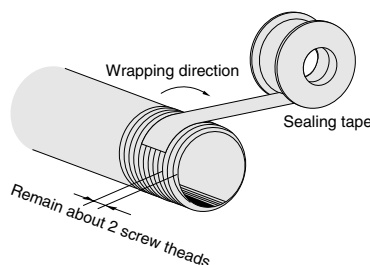

2. Tightening torque for piping

Connection thread	Suitable tightening torque N·cm (kgf·cm) [in·lbf]
M3	59 (6) [5.2]
M5×0.8	157 (16) [13.9]
Rc (PT) 1/8	686~883 (70~90) [60.8~78.1]
Rc (PT) 1/4	1177~1373 (120~140) [104~122]
Rc (PT) 3/8	2157~2354 (220~240) [191~208]
Rc (PT) 1/2	2746~2942 (280~300) [243~260]
Rc (PT) 3/4	2746~2942 (280~300) [243~260]
Rc (PT) 1	3530~3727 (360~380) [313~330]
Rc (PT) 1 1/4	3923~4119 (400~420) [347~365]
Rc (PT) 1 1/2	4707~4903 (480~500) [417~434]

Block-off plate

To close the unused stations, use a block-off plate.

For the order code, see the Additional Parts item under each series.

- Cautions:**
1. For the 1(P) port piping, use a size that matches the manifold's piping connection port.
 2. When installing piping or mufflers to the exhaust port, ensure there will be minimum exhaust resistance.
 3. On rare occasions, exhaust can interfere with other valves and actuators. In this case, let exhaust from the R ports on both ends.
 4. When a multiple number of valves are operating simultaneously on a multi-unit manifold, or during high frequency applications, supply air from the 1(P) ports on both ends, and let exhaust from the R ports on both ends.
 5. Since the twin solenoid valve uses 2 stations, it cannot be mounted on the final station.
 6. In the 025 series, the seal between the valve and manifold is used reversed top-to-bottom, in accordance with the valve function (NC or NO). Install the seal as the mark (NC or NO) is located on the valve side and matches the valve function.

Tube installation and removal

Insert the tube to connect as far as the tube stopper contacts the tubes. Pull the tube to confirm the connection.

For tube removal, push the release ring forward parallel to the ring, and pull the tube out.

Tubes

Either nylon or urethane tubes can be used. Use tubes that are not scratched on their outer surface.

The tube's outer diameter tolerance should be within ±0.1mm [±0.004in.] of the nominal dimension, and within 0.2mm [0.008in.] for the ellipticity (difference between long and short diameter).

Caution: Do not excessively bend the tube near fittings.