

KOGANEI

FA Series Flow Meter

Details

Instruction Manual Ver.1.0

Thank you for purchasing a Koganei FA Series Flow Meter.

To ensure safe use of this product, be sure to read the contents of this manual and gain an understanding of how to properly operate the product before actually trying to use it.





Keep this manual in a safe place for future reference.

Contents

<i>Safety Precautions</i>	2
<i>Handling Instructions and Precautions</i>	3
<i>Setup Guidelines</i>	7
<i>Maintenance and Troubleshooting</i>	14
<i>Bypass Unit Replacement Guidelines</i>	15
<i>Specifications</i>	16
<i>Order Codes</i>	17
<i>Pressure Loss</i>	18
<i>Dimensions</i>	19

Before selecting and using the products, please read all the Safety Precautions carefully to ensure proper product use. The Safety Precautions described below are to help you use the product safely and correctly, and to prevent injury or damage to you, other people, and assets. Always be sure to comply with ISO4414 (Pneumatic fluid power - Recommendations for the application of equipment to transmission and control systems) and JIS B8370 (Pneumatic system regulations) safety regulations.

The directions are ranked according to degree of potential danger or damage: “DANGER”, “WARNING”, “CAUTION”, and “ATTENTION”

 DANGER	Indicates situations that can be clearly predicted as dangerous. Failure to avoid the situation creates the risk of death or serious injury. It could also result in damage or destruction of assets.
 WARNING	Indicates situations that, while not immediately dangerous, could become dangerous. Failure to avoid the situation creates the risk of death or serious injury. It could also result in damage or destruction of assets.
 CAUTION	Indicates situations that, while not immediately dangerous, could become dangerous. Failure to avoid the situation creates the risk of minor or semi-serious injury. It could also result in damage or destruction of assets.
 ATTENTION	While there is little chance of injury, this content refers to points that should be observed for appropriate use of the product.

■ This product was designed and manufactured for use in general industrial machinery.

- When selecting and handling equipment, the system designer or another person with sufficient knowledge and experience should always read the Safety Precautions, catalog, Instruction Manual and other literature before commencing operation. Improper handling is dangerous.
- After reading the Instruction Manual, catalog, and other documentation, always store them in a location that allows easy availability for reference to users of this product.
- Whenever transferring or lending the product to another person, always attach the catalog, Instruction Manual, and other information to the product where they are easily visible in order to ensure that the new user can use the product safely and properly.
- The danger, warning and caution items listed under these Safety Precautions do not cover all possible contingencies. Read the catalog and Instruction Manual carefully, and always keep safety first.

 **DANGER**

- Do not use the product for the purposes listed below:
 1. Medical equipment related to maintenance or management of human lives or bodies.
 2. Machines or equipment designed for the purpose of moving or transporting people.
 3. Critical safety components in mechanical devices.
 This product has not been planned or designed for purposes that require high levels of safety. Using the product in any of the ways described above creates the risk of loss of human life.
- When mounting the product and workpiece, always make sure they are firmly supported and secured in place. Falling, dropping, or abnormal operation of the product creates the risk of personal injury.
- Never attempt to modify the product in any way. Doing so creates the risk of injury, electric shock, fire, etc.
- Never attempt inappropriate disassembly, assembly or repair of the product relating to basic construction, or to its performance or to functions. Doing so creates the risk of injury, electric shock, fire, etc.
- Do not splash water on the product. Water spraying on the product, washing the product, or using the product under water creates the risk of malfunction, leading to injury, electric shock, fire, etc.
- Do not use the product in locations with or near dangerous substances such as flammable or ignitable substances. This flow meter is not explosion-proof. Doing so creates the risk of ignition and fire.
- Do not attempt any adjustment (connecting or disconnecting tubes or connectors, piping work, etc.) to mechanisms attached to the product while the product is operating. Abnormal operation creates the risk of personal injury.

 **WARNING**

- Do not use the product in excess of its specification range. Doing so creates the risk of product breakdown, loss of function, or damage. It could also drastically reduce the product's operating life.
- Before supplying air or electricity to the device and before starting operation, always conduct a safety check of the area of machine operation. Unintentional supply of air or electricity could possibly result in electric shocks, or in injury caused by contact with moving parts.
- Do not touch terminals and other exposed electric parts while power is turned on. Doing so creates the risk of electric shock and abnormal operation.
- Do not allow the product to be thrown into fire. Doing so creates the risk of explosion, resulting in the release of toxic gasses.
- Do not sit on the product, place your foot on it, or place other objects on it. Doing so creates the risk of injury due to tripping or the product tipping over, resulting in product damage and abnormal, erratic, or runaway operation.

- When conducting any kind of operation for the product, such as maintenance, inspection, repair, or replacement, always turn off the air supply completely and confirm that residual pressure inside the product or in piping connected to the product is atmospheric pressure before proceeding. In particular, be aware that residual air will still be in the air compressor or air storage tank.
- Do not allow cables to be damaged. Allowing a cable to become cut, bent excessively, pulled, rolled up, placed under heavy objects, or squeezed between two objects creates the risk of current leaks or defective continuity that can lead to fire, electric shock, or abnormal operation.
- Do not allow the flow meter to be exposed to external magnetism while it is operating. Unintended movements could result in damage to the equipment or in personal injury.
- Use safety circuits or design a system that prevents damage to machinery and personal injury when the machine is shut down due to an emergency stop or electrical power failure.
- Do not share a conduit with or wire parallel to power lines or high voltage lines. Noise from these lines may cause the flow meter to operate erratically.
- When wiring, take care to ensure that wiring polarity is correct. Incorrect polarity creates the risk of damage to the flow meter.
- Do not use any type of medium that is not specifically stipulated in the specifications. Using a non-specified medium could lead to short term loss of function, sudden degradation of performance, and a reduced operating life.

 **CAUTION**

- Do not use in locations that are subject to direct sunlight (ultraviolet rays), dust, salt, iron powder, humidity, or in the media and/or the ambient atmospheres that include organic solvents, phosphate ester type hydraulic oil, sulfur dioxide, chlorine gas, acids, etc. It could lead to early shutdown of some functions or a sudden degradation of performance, and result in a reduced operating life. For the materials, see the Major Parts and Materials.
- When installing the product, be sure to allow adequate work space around it. Failure to do so will make it more difficult to conduct daily inspections or maintenance, which could eventually lead to system shutdown or damage to the product.
- Do not use the flow meter in locations subject to large electrical currents or strong magnetic fields. It could result in erratic operation.
- Do not scratch, dent, or deform the product by climbing on it, using it as a scaffold, or placing objects on top of it. Doing so creates the risk of damage to or breakage of the product, resulting in operational shutdown or degraded performance.
- Always post an "operations in progress" sign for installations, adjustments, or other operations, to avoid unintentional supplying of air or electrical power, etc. Unintended air or power supply can cause electric shock or sudden operation, creating the risk of personal injury.

Safety Precautions

- Do not subject the flow meter cables to excess load by pulling on them, by picking up the flow meter by them, or by placing heavy objects on them. Such actions could result in current leaks or defective continuity that lead to fire, electric shocks, or abnormal operation.
- While handling the flow meter, do not subject it to excessive shock (490 m/s² or greater) by hitting, dropping or bumping it. Even if the product appears undamaged, damage to internal components can cause abnormal operation.
- Avoid load short-circuit conditions.
Turning on switch output while a load short-circuit condition exists can cause damage to the flow meter due to over current.
Load short-circuit example: Connecting output lead wires of switch output to DC power supply.

ATTENTION

- Whenever considering use of this product in situations or environments not specifically noted in the catalog or instruction manual, or in applications where safety is an important requirement such as in aviation facilities, combustion equipment, leisure equipment, safety equipment, and other places where human life or assets may be greatly affected, take adequate safety precautions such as allowing plenty of margin for ratings and performance, or fail-safe measures. Be sure to consult us with such applications.
- Always check the catalog and other reference materials for product wiring and piping.
- Do not configure control of the system in a way that could cause workpieces to fall due to power failure.
Configure control of the system to prevent workpieces and other items from falling due to power failure or by emergency stops of mechanical devices.
- When handling the product, wear protective gloves, safety glasses, safety shoes, and other protective clothing.
- When the product can no longer be used or is no longer necessary, dispose of it appropriately as industrial waste.
- Pneumatic equipment can exhibit degraded performance and function over its operating life. Always conduct daily inspections of the pneumatic equipment, and confirm that all requisite system functions are satisfied, to prevent accidents from happening.
- For inquiries about the product, consult your nearest Koganei sales office or Koganei Overseas Department. The addresses and telephone numbers are shown on the back cover of this catalog.

Other

- Always observe the following items.
 1. When using this product in a system, use only genuine Koganei parts or equivalent (recommended) parts.
When conducting maintenance and repairs, always use genuine Koganei parts or compatible parts (recommended parts).
Always observe the prescribed methods and procedures.
 2. Never attempt inappropriate disassembly or assembly of the product relating to basic configurations, or its performance or functions.

Koganei shall not be held responsible for any problems that occur as a result of these items not being properly observed.

Handling Instructions and Precautions



General Precautions

Mounting location

Avoid installing the FA Series Flow Meter in the following types of locations.

1. Locations where the ambient temperature or product temperature is -10°C or less or exceeds 60°C .
2. Locations where the ambient humidity exceeds 90% RH.
3. Locations subjected to sudden temperature changes that can cause condensation.
4. Locations subjected to concentrations of corrosive and/or flammable gasses.
5. Locations subjected to high amounts of dust, salt, iron powder, or other conductive matter, moisture, oil mist, or organic solvents.
6. Locations where the product is directly subjected to vibration and/or impact.
7. Locations exposed to direct sunlight.
8. Locations where water, rain, or other moisture can get on the product.
9. Locations where oil or chemicals can get on the product.
10. Locations that are always wet or dusty, or subject to water or dust.
11. Locations where strong magnetism or strong electric fields are being generated.

Operation when the maximum flow rate range is exceeded

When the flow rate exceeds the maximum flow rate range of the FA Series Flow Meter, the alarm message "RL4D" will alternate on the display with the flow rate reading. Always use this flow meter within the specified maximum flow rate range.



Installation and Piping

Piping

1. The FA Series Flow Meter is a precision instrument. Take care when handling it. It can be damaged by dropping it or otherwise subjecting it to strong impact.
2. Whenever connecting piping to the FA Series Flow Meter, make sure that the direction of the arrow marked on it matches the flow direction of the fluid.
3. When connecting piping, do not apply force to the bypass unit section.
4. When connecting piping, secure the main flow channel and rotate the pipe to the suitable tightening torque range.

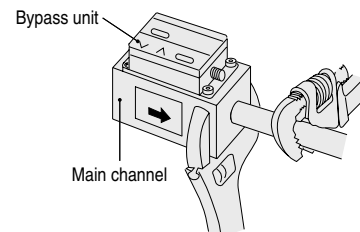

Model	Port size Rc	Suitable tightening torque N·m
FAS-002	1/4	12 to 14
FAS-005	1/2	31 to 33
FAS-030	1	36 to 38
FAS-060	1 1/2	59 to 61
FAS-120	2	74 to 76

5. Take care to keep foreign matter from flowing into the FA Series Flow Meter. Any rust, water droplets, oil mist, dust, or other foreign matter inside piping that gets into the FA Series Flow Meter creates the risk of measurement error and damage to the flow meter. Before installation, be sure to thoroughly flush both the upstream and downstream piping (pipe cleaning) and check to make sure there is no foreign matter present.

Handling Instructions and Precautions

6. When connecting piping, apply an appropriate amount of sealant. Do not apply sealant to the first two threads of the end of the pipe. Over-application of sealant can cause it to get inside the piping, creating the risk of measurement error and damage to the FA Series Flow Meter.

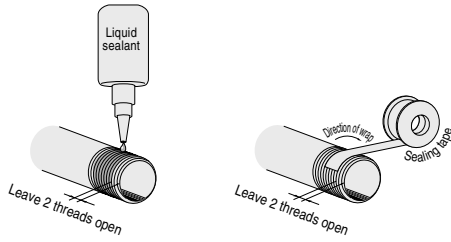

- 7. If different-diameter piping, a regulator, filter, valve, or other piping equipment is installed upstream from the FA Series Flow Meter, be sure to provide a straight pipe section as recommended. See "Specification accuracy and straight pipe section" for more information. Failure to provide a straight pipe section can cause flow rate errors.
- 8. Connecting expansion pipe or a tube coupler without providing a straight pipe section can produce a negative flow rate reading due to back flow in bypass unit, even though there is normal flow as far as the product is concerned.
- 9. Installing the display section on horizontal piping so it is in a downward orientation may cause rust, water droplets, oil mist, dust, or other foreign matter to adhere to the sensor, creating the risk of measurement errors and damage to the FA Series Flow Meter. Do not use the display section in a downward orientation. Installing the display section on horizontal piping in a sideways orientation will cause errors due to the effect of the attitude. For details, see "Installation Attitudes" below.
- 10. Do not install in locations where the effects of pulsating flow or flow maldistribution are present, such as in the vicinity of the compressor delivery port, on bellows piping, etc. Also, do not install in a location where a regulator or check valve is performing hunting. Doing so creates the risk of measurement error.

Installation attitude

Installation attitude 1: Installation on horizontal piping, the display up. (Standard installation)

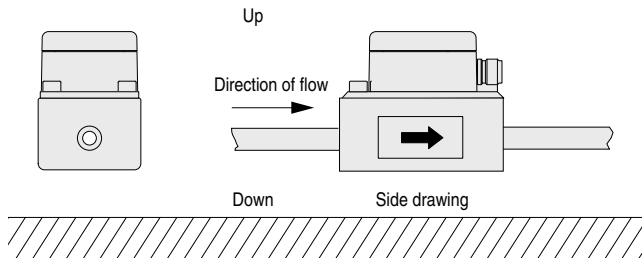

Installation attitude 2: Installation on horizontal piping, the display on the right when viewed from the flow meter IN side pipe. When using this installation attitude, set the low flow cut parameter value to 5. Failure to do so will cause the flow rate to be displayed (output) even when there is no fluid flowing. The normal flow side and back flow side integral functions activate, causing the flow rate values to be integrated.

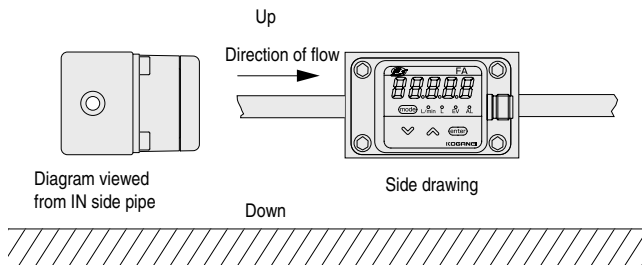

Operating pressure range	Flow rate range	Instantaneous flow rate display change amount
0 to 1 MPa	5 to 100% of FS flow rate ^{Note}	No more than 0.5% FS/0.1 MPa ± 1 digit
-0.07 to 0 MPa	5 to 100% of FS flow rate	No more than 0.5% FS/0.01 MPa ± 1 digit

Note: "FS flow rate" is the "full-scale flow rate".

Example At a pressure of 0.3 MPa when the flow meter is installed on horizontal piping with the display facing to the right, when viewed from the flow meter IN side pipe, causes a change in the flow rate that is no more than 1.5% FS ± 1 digit compared to the normal installation attitude.
 $0.5[\%FS/0.1MPa] \times 0.3[MPa] = 1.5[\%FS]$

Installation attitude 3: Installation on horizontal piping, the display on the left when viewed from the flow meter IN side pipe. When using this installation attitude, set the low flow cut parameter value to 5. Failure to do so will cause the flow rate to be displayed (output) even when there is no fluid flowing. The normal flow side and back flow side integral functions activate, causing the flow rate values to be integrated.

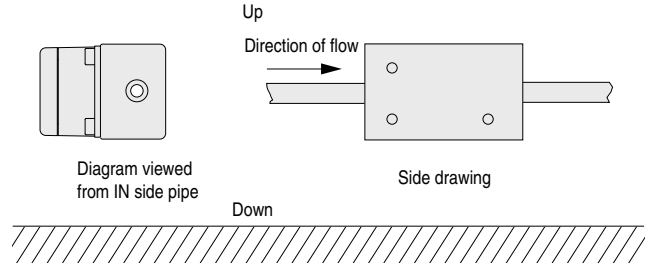

Operating pressure range	Flow rate range	Instantaneous flow rate display change amount
0 to 1 MPa	5 to 100% of FS flow rate	No more than -0.5% FS/0.1 MPa ± 1 digit
-0.07 to 0 MPa	5 to 100% of FS flow rate	No more than -0.5% FS/0.01 MPa ± 1 digit

Example At a pressure of 0.3 MPa when the flow meter is installed on horizontal piping with the display facing to the right when viewed from the flow meter IN side pipe, causes a change in the flow rate that is no more than -1.5% FS ± 1 digit compared to the normal installation attitude.
 $-0.5[\%FS/0.1MPa] \times 0.3[MPa] = -1.5[\%FS]$

Installation attitude 4: Installation on horizontal piping, the display down. Do not use the flow meter in this installation attitude.

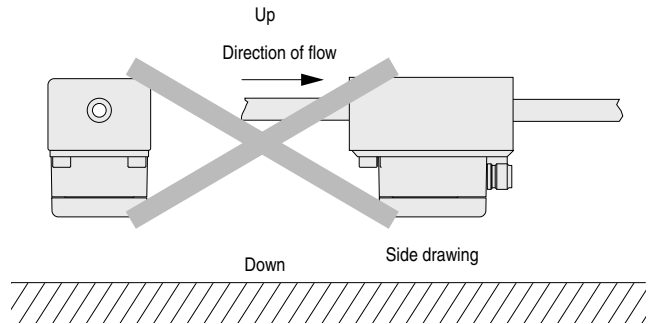

Installation attitude 5: Installation on vertical piping

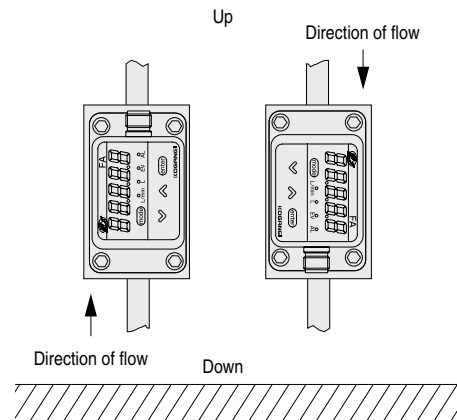

Handling Instructions and Precautions

Filter

- Whenever there is the risk of foreign matter (dust, sediment, oil mist, etc.) being mixed in with the measured fluid, be sure to install upstream from the FA Series Flow Meter a filter and mist filter that can remove foreign matter measuring $1\ \mu\text{m}$ or larger.
- Periodically inspect and replace filters, and perform any other necessary filter maintenance.

Specification accuracy and straight pipe section

Install the FA Series Flow Meter so the arrow marked on its label is pointed in the same direction as the fluid flow direction. When connecting different diameter tubing, valves, filters, and other equipment, provides straight pipe in accordance with the information in the table below.

A "straight pipe" is straight piping that is the same bore diameter as the flow meter. The following types of pipes are suitable as straight pipe: carbon steel pipes for ordinary piping (JIS G3452), carbon steel pipes for pressure service (JIS G3454), Schedule 40 or less, and stainless steel pipes (JIS G3459), Schedule 40. ^{Note 1.}

For equipment not included in the table below, provide 15D or larger straight piping when installing it upstream from the FA Series Flow Meter, and 5D or larger straight piping when installing it downstream from the FA Series Flow Meter. The letter D represents the bore diameter. ^{Note 2.}

When measuring back flow in addition to normal flow, the same length as the upstream straight pipe is required downstream from the FA Series Flow Meter.

Pipe, connected equipment	Connection location	Straight pipe section for FA Series Flow Meter	
		Specification range Within ($\pm 3\%$ FS)	Accuracy Within $\pm 5\%$ FS
Mist filter For FAS-002, FAS-005, FAS-030 ^{Notes 3, 5}	Upstream from flow meter	10D	Not required
Mist filter For FAS-060, FAS-120 ^{Notes 4, 5}	Upstream from flow meter	20D	Not required
1 size larger bore diameter piping (contraction piping connection) FAS-002 3/8B → 1/4B FAS-005 3/4B → 1/2B FAS-030 1 1/4B → 1B FAS-060 2B → 1 1/2B ^{Note 6}	Upstream from flow meter	5D	Not required
	Downstream from flow meter	Not required	Not required
		Not required	Not required
	More than 1 size larger bore diameter piping (contraction piping connection) FAS-120 2 1/2B → 2B ^{Note 6}	Upstream from flow meter	10D
Downstream from flow meter		5D	5D
1 size smaller bore diameter piping (expansion piping connection) FAS-002 1/8B → 1/4B FAS-005 3/8B → 1/2B FAS-030 3/4B → 1B FAS-060 1 1/4B → 1 1/2B ^{Note 7}	Upstream from flow meter	15D	Not required
	Downstream from flow meter	Not required	Not required
		Not required	Not required
	More than 1 size smaller bore diameter piping (expansion piping connection) FAS-120 1 1/2B → 2B ^{Note 7}	Upstream from flow meter	25D
Downstream from flow meter		5D	5D
Single elbow ^{Note 8}	Upstream from flow meter	10D	Not required
	Downstream from flow meter	Not required	Not required
Double elbow ^{Note 8}	Upstream from flow meter	10D	10D
	Downstream from flow meter	Not required	Not required
Ball valve (Full bore type, fully open) ^{Note 9}	Upstream from flow meter	20D	10D
	Downstream from flow meter	10D	5D
Regulator ^{Note 10} FAS-002	Upstream from flow meter	200D	Not required
	Downstream from flow meter	10D	Not required
Regulator ^{Note 10} FAS-005, FAS-030, FAS-060, FAS-120	Upstream from flow meter	30D	Not required
	Downstream from flow meter	5D	Not required
Air filter	Upstream from flow meter	25D	Not required

Note 1: Note that accuracy deteriorates when piping carbon steel pipes for pressure service (JIS G3454) or stainless steel pipes (JIS G3459), larger than Schedule 40 is connected. A larger schedule results in a smaller pipe inside diameter which causes a pipe effect and deteriorated accuracy.

2: The approximate D (bore diameter) for FAS-002 (1/4B) is 8 mm, for FAS-005 (1/2B) is 15 mm, for FAS-030 (1B) is 25 mm, for FAS-060 (1 1/2B) is 40 mm, and for FAS-120 (2B) is 50 mm.

3: Always provide a filter upstream from the mist filter.

Note 4: Contact Koganei about 1 1/2B and 2B size filters and mist filters.

5: Straight pipe section required connecting a filter with the same bore diameter as the flow meter.

6: An example of connecting contraction piping on FAS-002 (product specification range of within $\pm 3\%$ FS) is shown below.

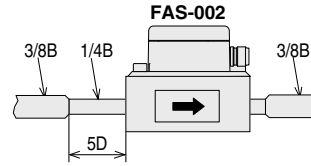

When connecting piping one size larger (such as 1/2B on FAS-002), use a prescribed value of +5D for the upstream straight pipe section* and +5D for the downstream straight pipe section.

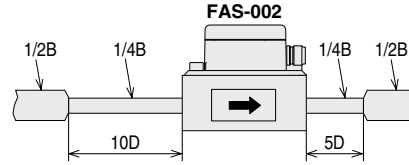

* Length when piping one size larger than the prescribed value is connected.

7: An example of connecting expansion piping on FAS-005 (product specification range of within $\pm 3\%$ FS) is shown below.

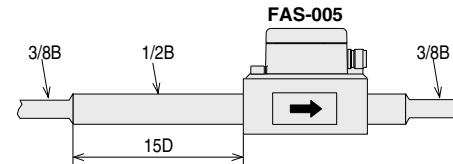

Do not connect piping with a diameter smaller than the connection pipe bore diameter without straight section piping. Even if flow in the main channel itself is normal direction flow, bypass unit back flow can produce a negative reading. Also, the readout may show an extremely low flow rate instead of the actual flow rate. When connecting piping one size smaller (such as 1/4B on FAS-005), use a prescribed value of +10D for the upstream straight pipe section* and +5D for the downstream straight pipe section.

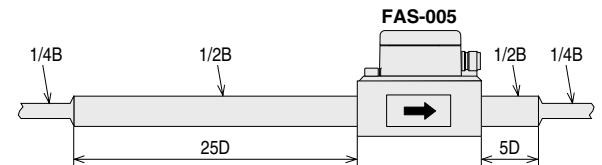

* Length when piping one size smaller than the prescribed value is connected.

8: The illustration below shows single-elbow and double-elbow configuration.

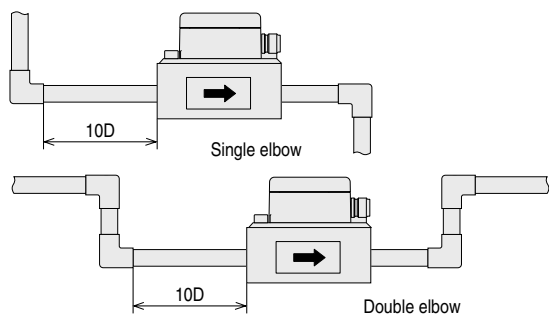

9: Install the flow rate adjustment valve downstream from the flow meter.

10: The distance from the flow meter to an elbow should be greater than the prescribed length. Piping from the regulator to the flow meter can be either tube piping or bent by an elbow. However, when connecting to the flow meter with an elbow be sure to provide the straight pipe section required by the elbow. Provide distance when installing a filter and mist filter between the flow meter and elbow.

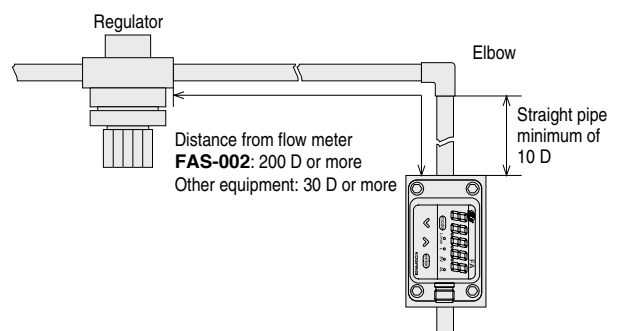

Handling Instructions and Precautions

Connecting to a quick fitting

Provide the straight pipe section noted in the table below when connecting the FA Series Flow Meter to a quick fitting. Connecting without a straight pipe section can produce a negative reading due to bypass unit back flow, even if flow in the main channel itself is normal direction flow. Also, the readout may show an extremely low flow rate instead of the actual flow rate.

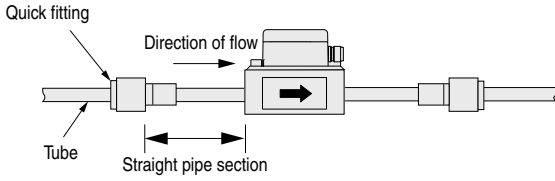

Pipe, connected equipment	Fitting type	Connection location	Straight pipe section for FA Series Flow Meter	
			Specification range ^{Note} Within (±3%FS)	Accuracy ^{Note} Within ±5%FS
Quick fitting Tube size φ 8 (For FAS-002)	Straight type	Upstream from flow meter	15D	5D
		Downstream from flow meter	Not required	Not required
	Elbow type	Upstream from flow meter	20D	10D
		Downstream from flow meter	5D	5D
Quick fitting Tube size φ 12 (For FAS-002)	Straight type	Upstream from flow meter	5D	Not required
		Downstream from flow meter	Not required	Not required
	Elbow type	Upstream from flow meter	10D	5D
		Downstream from flow meter	5D	5D
Quick fitting Tube size φ 12, φ 16 (For FAS-005)	Straight type	Upstream from flow meter	10D	5D
		Downstream from flow meter	Not required	Not required
	Elbow type	Upstream from flow meter	15D	10D
		Downstream from flow meter	5D	5D
Quick fitting Tube size φ 12, φ 16 (For FAS-030)	Straight type	Upstream from flow meter	10D	8D
		Downstream from flow meter	5D	5D
	Elbow type	Upstream from flow meter	15D	13D
		Downstream from flow meter	10D	10D

Note: Characteristics when the tube is extended straight out from the fitting about 300 mm.

Wiring

1. Use a power supply that is within the specification range.
2. Wire a cable with connector separately from power lines and high voltage lines (use a separate conduit). Noise from these lines may cause the equipment to operate erratically.
3. When connecting a cable with connector, align the core wire and push it in as far as it will go. Next, tighten the connector nut by hand. When tightening the nut, be sure to keep it within the prescribed torque (no more than 0.4 to 0.6 N · m). Failure to do so creates the risk of damage to the FA Series Flow Meter and inability to maintain the IP65 protective structure, and loosening of the nut due to vibration.
4. Do not pull on the cable with strong force and do not lift the FA Series Flow Meter by the cable (pull out strength: 40 N or less; bend strength; 20 N or less). Also, do not subject the cable to repeated bending or pulling force.
5. Do not rotate the center part of the connector (see figure below) while the connector is inserted fully into the FA Series Flow Meter. Doing so will cause the FA Series Flow Meter connector to rotate, which can cause internal wiring to twist and become damaged.

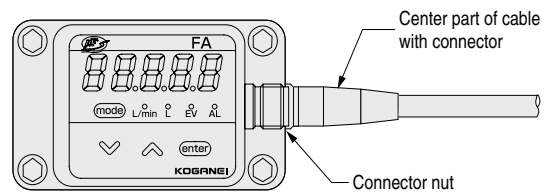

6. Always turn off the power supply before doing any wiring.
7. Keep load resistance connected to the instantaneous flow rate output below 300 Ω.
8. Keep cable and connector ends away from moisture when doing wiring.
9. Double-check to make sure that wiring is correct before turning on power. Wiring error creates the risk of damage and erratic operation.

Pin No.	Signal name	Description
1	V+	24VDC
2	I+	Instantaneous flow rate output (4-20 mA)
3	COM	COM
4	EV	Switch output

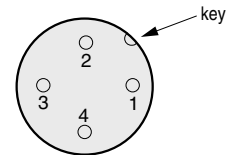

Cable wire colors and pin numbers

Pin No.	Signal name	Lead color
1	V+	Brown
2	I+	White
3	COM	Blue
4	EV	Black

Example connection

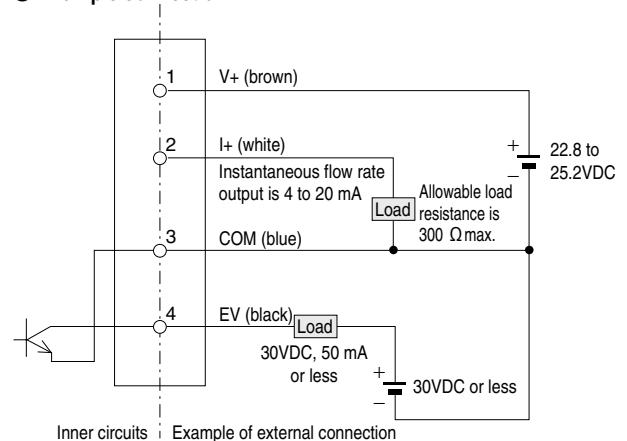

Setup Guidelines

Switch output

● Switches

One of the switches shown in the table below can be selected. Except for integrated pulse output, you can also select inverted output.

Switch	Operation
Instantaneous flow rate upper limit switch	Outputs when the value set with the instantaneous flow rate switch 1 parameter is exceeded.
Instantaneous flow rate lower limit switch	Outputs when the value set with the instantaneous flow rate switch 1 parameter is subceeded.
Instantaneous flow rate range switch	Outputs when instantaneous flow rate is within the range set by instantaneous flow rate switch 1 and instantaneous flow rate switch 2.
Integrated flow rate count up switch	Outputs when the value set with the integrated switch setting parameter is exceeded.
Integrated flow rate countdown switch	Outputs when a value of zero results after the value set with the integrated switch setting parameter is decremented.
Integrated pulse output	Performs pulse output of the integrated flow rate with the pulse weight set by switch output of the function setting. Function settings can be used to select a pulse width of 50 ms, 250 ms, or 500 ms. For information about the pulse weights see the table below.
Alarm output	Outputs when an alarm is generated.

Model-specific pulse weight

Model	Setting [ℓ /pulse]			Setting [m ³ /pulse, kg/pulse]		
	Minimum unit	Minimum unit x 10	Minimum unit x 100	Minimum unit	Minimum unit x 10	Minimum unit x 100
FAS-002	10	100	1000	0.01	0.1	1
FAS-005	10	100	1000	0.01	0.1	1
FAS-030	10	100	1000	0.01	0.1	1
FAS-060	100	1000	10000	0.1	1.0	10.0
FAS-120	100	1000	10000	0.1	1.0	10.0

● Switch hysteresis

When the instantaneous flow rate switch is selected, sets the hysteresis (operation interval).

● Switch on delay

When the instantaneous flow rate switch is selected, sets the delay until switch operation.

● Switch wait

When the instantaneous flow rate lower limit switch of the instantaneous flow rate switch is selected, specifies switch operation wait unit a lower limit setting value is exceeded once before power is turned on.

Displays

● Instantaneous flow rate screen and integrated flow rate screen

The seven segments of the display can be switched between instantaneous flow rate and integrated flow rate. Up to five digits are used for instantaneous flow rate display. A total of nine digits are shown for integrated flow rate value, with the displayed value is divided between the four highest digits five lowest digits.

When the four highest digits are displayed, the leftmost 7-segment LED shows “H” for countup or “d” for countdown. If there is no countdown/up indication, it means that the lowest digits are displayed.

● Instantaneous flow rate peak value and lower value

These values show the instantaneous flow rate peak value and low value during the measurement period. The measurement period can be reset (started) using a key operation.

● Information display

The information display function can be used to view the model ID, firmware version, cumulative integrated values, and integrated value before integration reset.

Flow rate display unit

The display unit for instantaneous flow rate and integrated flow rate can be changed as required.

Flow rate display example

Display unit setting	C02 : 00	C02 : 01	C02 : 02	C02 : 03
Unit	ℓ /min, ℓ	m ³ /h, m ³	m ³ /min, m ³	kg/h, kg
Instantaneous flow rate	200	12.0	0.200	15.5
Integrated flow rate	100000000	100000.000	100000.000	100000.000

Conversion from ℓ /min to each unit are shown below.

$$\text{m}^3/\text{h} = \ell / \text{min} \times 60 \div 1000$$

$$\text{kg}/\text{h} = \ell / \text{min} \times 60 \div 1000 \times 1.293$$

Density at 0°C and 101.325 kPa (abs) is assumed to be 1.293.

Note: After changing the unit of flow rate display, select the applicable sticker from among those provided and affix it to the flow meter.

Analog output

The instantaneous flow rate is output as an analog current (4 to 20 mA). Parameter settings can be used to change the flow rate value (display value) at 20 mA output. Setting resolution can be set in display value 1-digit intervals. Initial default settings are 4 mA at flow rate 0, and 20 mA at 100% FS flow rate.

Operating pressure selection

Selecting a value that is in the vicinity of operating pressure will perform output compensation of the selected pressure and reduce the effects of pressure characteristics.

Reference temperature selection

The flow rate display reference temperature can be set in 1°C steps within the range of 0 to 35°C.

(Factory default temperature is 0°C.)

Low flow cut

Low flow cut can be set in 1% steps within the range of 1 to 50% of FS flow rate (factory default: 1%).

At a setting of 1%, for example, 0 is always displayed as the flow rate when the FS flow rate is within the range of -1 to 1%.

The low flow cut setting is applied to instantaneous flow rate and integrated display values, and to the analog output value.

Self-diagnostic function

The self-diagnostic function automatically causes the FA Series Flow Meter to display an alarm whenever there is an abnormality in the output signal of the sensor that measures the flow rate or a memory abnormality.

Back flow measurement

Enables measurement of back flow up to -30% of the FS flow rate.

Note: For information about accuracy, see the specifications on page 16 and 17.

Flow rate range expansion function

Enables measurement up to 200% of the FS flow rate.

Note: For information about accuracy, see the specifications on page 16 and 17.

Setup Guidelines

Settings

● Mode navigation

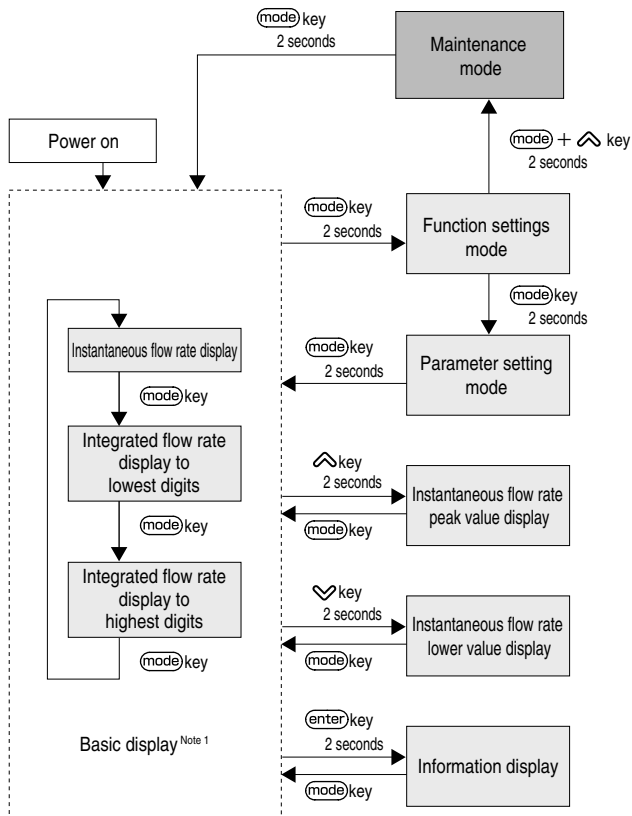

Note 1: The basic screen shows instantaneous flow rate, integrated flow rate lowest digits, or integrated flow rate highest digits, in accordance with the **C04** function number setting.

When an alarm is generated, the alarm code and basic screen alternate at an interval of two seconds.

Each press of the **(mode)** key cycles through the screens in the following sequence: Instantaneous flow rate → Integrated flow rate lowest digits → Integrated flow rate highest digits → Alarm code → Instantaneous flow rate.

2: Integrated value reset

While the integrated flow rate highest digits or lowest digits are displayed, hold down the **∨** and **∧** keys at the same time for about five seconds.

Normally this will reset the integrated value to "0". However, when the switch output select **C03** is configured for integration countdown (**09** or **10**), the integration switch setting values (**E 14 1** and **E 14 0**) will be set.

⚠ CAUTION

Do not operate keys by pressing with a mechanical pencil, a screw driver, or any other pointed object. Doing so can lead to malfunction.

● Function settings

① While the basic screen is displayed, hold down the **(mode)** key for about two seconds.

The three digits on the left will show the function number, while the two digits on the right will show the current setting of the function.

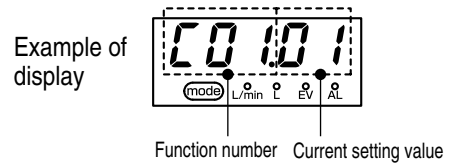

② Use the **∨** and **∧** keys to scroll through the function numbers and display the one you want to change. Next, press the **(enter)** key. This will cause the function number to disappear, leaving the two-digit setting value on the display.

③ Use the **∨** and **∧** keys to scroll through the settings and display the one you want. Next, press the **(enter)** key. This will apply the setting and display the corresponding function number and setting value. Instead of pressing the **(enter)** key in the above procedure, pressing the **(mode)** key will return to the function number/setting value display without changing the setting.

④ To configure other settings, repeat steps ② and ③ as many time as required.

To exit function selection, hold down the **(mode)** key for about two seconds to change to the parameter setting screen. Next, hold down the **(mode)** key again for about two seconds to return to the basic screen.

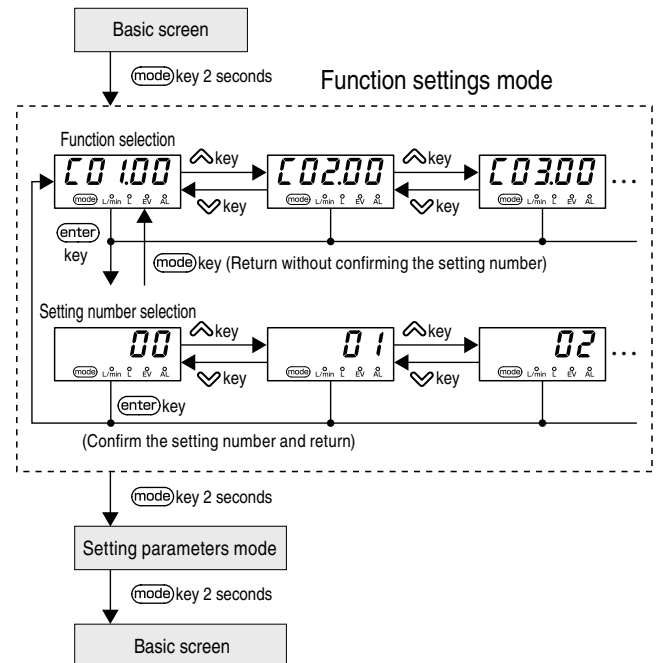

Setup Guidelines

Function setting list

Function number	Description	Setting number and description	Default	Remarks
C01	Setting key lock	00: No key lock 01: Key lock	00	You can also use this setting to cancel key lock. Performing a change operation while key lock is engaged will cause "LoL" to be displayed.
C02	Display unit setting	Instantaneous flow rate, integrated flow rate ^{Note} 00: ℓ /min, ℓ 01: m ³ /h, m ³ 02: m ³ /min, m ³ 03: kg/h, kg	00	Caution: After changing the unit, existing integrated values continue to be integrated in the previous unit. They are not converted automatically. After changing the unit, reset integration before using it again. • The peak value and lower value are reset when the unit is changed.
C03	Switch output	00: Not used 01: Instantaneous flow rate upper limit 02: Instantaneous flow rate lower limit 03: Instantaneous flow rate range 04: Instantaneous flow rate upper limit (inverted) 05: Instantaneous flow rate lower limit (inverted) 06: Instantaneous flow rate range (inverted) 07: Integrated count up 08: Integrated count up (inverted) 09: Integrated countdown 10: Integrated count down (inverted) 11: Integrated pulse (minimum unit) 12: Integrated pulse (Minimum unit x 10) 13: Integrated pulse (Minimum unit x 100) 14: Alarm generation switch 15: Alarm generation switch (inverted)	00	Inversion causes output ON and OFF to be inverted.
C04	Basic screen	00: Instantaneous flow rate screen 01: Integrated lowest digit screen 02: Integrated highest digit screen	00	Determines the content of the flow rate display when power is turned on. The function setting mode is entered from the basic screen.
C07	Switch wait	00: Not used 01: Use	00	
C08	Gas type	00: Air, nitrogen (fixed)	00	Cannot be changed.
C10	Operating pressure	00: 0.3 MPa standard 01: 0.1 MPa standard 02: 0.5 MPa standard 03: 0.7 MPa standard	00	When the installation attitude is "Installation attitude 2" or "Installation attitude 3", error due to installation attitude can be reduced by maintenance mode pressure compensation adjustment value and operating pressure. For details, see "Maintenance Mode" on page 13.
C11	Reference value conversion	00 to 35°C (1°C steps)	00	Changing setting resets peak value and lower value.
C12	Integration options	00: Integration with only normal flow rate 01: Integration with back flow compensation	00	
C14	Integrated pulse width	00: 50 ms 01: 250 ms 02: 500 ms	00	
C15	Fixed output during alarm	00: Not used 01: Up 02: Down (fixed)	00	Outputs a fixed value from instantaneous flow rate output when a sensor abnormality or memory abnormality occurs. Flow rate indication is zero when an alarm occurs.

Note: After changing the display unit setting, select the provided sticker that corresponds to the new unit and affix it to the flow meter.

Setting parameters

- While the basic screen is displayed, hold down the (mode) key for about two seconds to enter the function select mode. Next, hold down the (mode) key again for about two seconds to enter parameter setting mode.

Example of display when setting parameter items

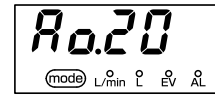

Example of display during setting

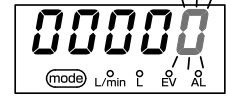

- Use the (left arrow) and (right arrow) keys to scroll through the setting items and display the one you want. Next, press the (enter) key. This will display a value with the rightmost digit flashing.

- Press the (mode) key to move the flashing to the left.

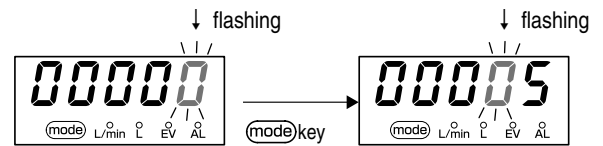

- Use the (left arrow) and (right arrow) keys to change the value of the currently flashing digit. Use the (left arrow) and (right arrow) keys to change each of the digits until the value is the one you want.

- After the value is the one you want, press the (enter) key. This will display the setting item and its set value.

- To configure other settings, repeat steps 2 through 5 as many times as required.

- To exit the setting procedure, while a setting item is displayed hold down the (mode) key for about two seconds to return to the basic screen.

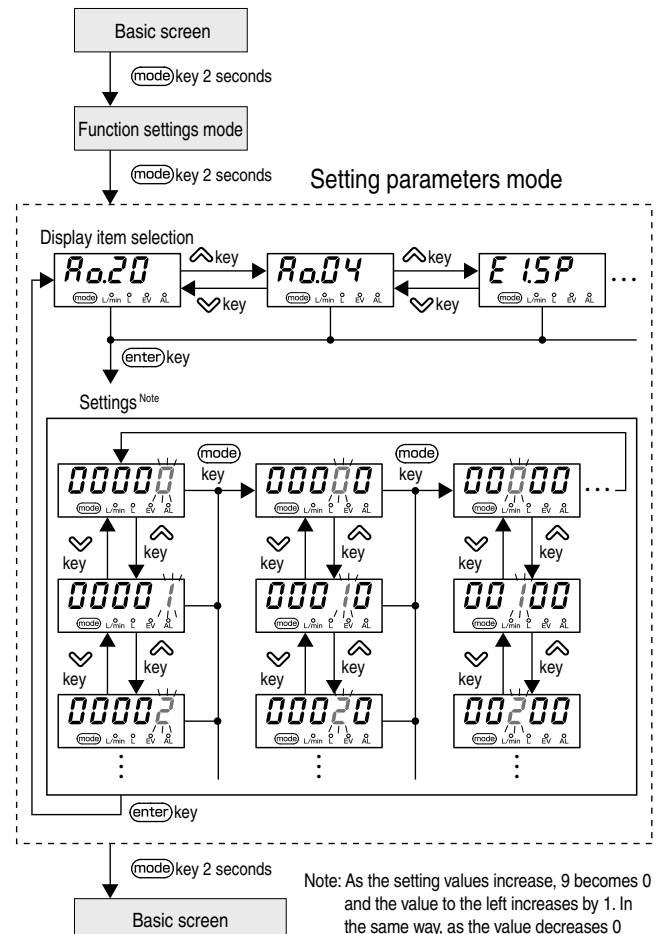

Note: As the setting values increase, 9 becomes 0 and the value to the left increases by 1. In the same way, as the value decreases 0 becomes 9 and the value to the left decreases by 1.

Setup Guidelines

Parameter setting list

Display item	Item content	Setting range	Default	Remarks
<i>R020</i>	Analog output 20 mA flow rate specification <small>Note 1</small>	Flow rate value equivalent to 0 to 400% FS can be set. <small>Note 5</small>	Depends on model number.	<ul style="list-style-type: none"> Initial default depends on model. FAS-002 → 200 FAS-005 → 500 FAS-030 → 3000 FAS-060 → 6000 FAS-120 → 12000 Setting ranges are values with decimal points removed. Decimal points will be added with model settings. Expected output cannot be obtained when the setting values is less than 10% of FS. Setting zero outputs fixed output during an alarm. Reconfigure this setting after changing the display unit setting with function selection Ⓒ02.
<i>R004</i>	Analog output 4mA flow rate specification <small>Note 1</small>	Flow rate value equivalent to 0 to 400% FS can be set. <small>Note 5</small>	0	<ul style="list-style-type: none"> Settings are values with decimal points removed. Decimal points will be added with model settings.
<i>E15P</i>	Instantaneous flow rate switch Output 1 <small>Note 2</small>	Flow rate value equivalent to 0 to 400% FS can be set. <small>Note 5</small>	0	<ul style="list-style-type: none"> This setting can be configured when function selection Ⓒ03 is set to 01 through 06.
<i>E1HYS</i>	Switch output hysteresis 1 <small>Note 2</small>	0 to 10% FS flow rate	1	<ul style="list-style-type: none"> Settings are values with decimal points removed. Decimal points will be added with model settings. Reconfigure this setting after changing the display unit setting with function selection Ⓒ02.
<i>E1dLY</i>	Switch output on delay 1 <small>Note 3</small>	0 to 60 s	0	<ul style="list-style-type: none"> Reconfigure this setting after changing the display unit setting with function selection Ⓒ02.
<i>E25P</i>	Instantaneous flow rate switch output 2 <small>Note 2</small>	Flow rate value equivalent to 0 to 400% FS can be set. <small>Note 5</small>	0	<ul style="list-style-type: none"> This setting can be configured when function selection Ⓒ03 is set to 03 or 06.
<i>E2HYS</i>	Switch output hysteresis 2 <small>Note 2</small>	0 to 10% FS flow rate	1	<ul style="list-style-type: none"> Settings are values with decimal points removed. Decimal points will be added with model settings. Reconfigure this setting after changing the display unit setting with function selection Ⓒ02.
<i>E2dLY</i>	Switch output on delay 2 <small>Note 3</small>	0 to 60 s	0	<ul style="list-style-type: none"> Reconfigure this setting after changing the display unit setting with function selection Ⓒ02.
<i>CF</i>	Output compensation factor	0.100 ~2.000	1.000	Can be set in 0.001 steps. Display value is reflected in output. Changing setting resets peak value and lower value.
<i>LFcut</i>	Low flow cut	1~50%	1	Applied to both normal and back flow.
<i>HILT</i>	Maximum display value	100~200%	200	Changes display range maximum value from standard 200% of FS. When flow rate exceeds setting value, set maximum display value alternates with error display RL40 (flow rate over).
<i>EILO</i>	Integration switch setting value lowest digits	00000 ~99990	0	Can be configured when function selection Ⓒ03 is set to 07 through 10 .
<i>EIH1</i>	Integration switch setting value highest digits	0000 ~9999	0	
<i>Cost</i>	Cost rate <small>Note 4</small>	1.0 ~100.0	100.0	Specifies the cost rate when cost is displayed on information display.

Note 1: Analog output scaling

Output for an instantaneous flow rate value is calculated using the formula below.

$$\frac{([\text{Indicated Flow Rate}] - [4 \text{ mA Setting Value}])}{([20 \text{ mA Setting Value}] - [4 \text{ mA Setting Value}])} \times 16 + 4 \text{ [mA]}$$

4 mA setting value : Instantaneous flow rate when 4 mA is output
 20 mA setting value : Instantaneous flow rate when 20 mA is output

- Minus flow output limit is 3.2 mA, plus side output upper limit is 20.8 mA.
- When $[4 \text{ mA Setting Value } R004] \geq [20 \text{ mA Setting Value } R020]$, a fixed output value will be output during an alarm.
- When $[20 \text{ mA Setting Value}] - [4 \text{ mA Setting Value}] < 10\%$ of FS flow rate, resolution is insufficient so desired output may not be possible.

Note 2: Instantaneous flow rate switch operation

Operation depends on the setting of function selection **Ⓒ03**.

- When function selection **Ⓒ03** is set to **01** or **04** (instantaneous flow rate upper limit switch) After exceeding the instantaneous flow rate upper limit value and the switch turning on, the settings for conditions to turn the switch off are set to hysteresis. $[\text{Switch OFF Conditions}] = [\text{Instantaneous Flow Rate Upper Limit Value}] - [\text{Hysteresis}]$ Hysteresis is specified as a percentage (%) of the FS flow rate.

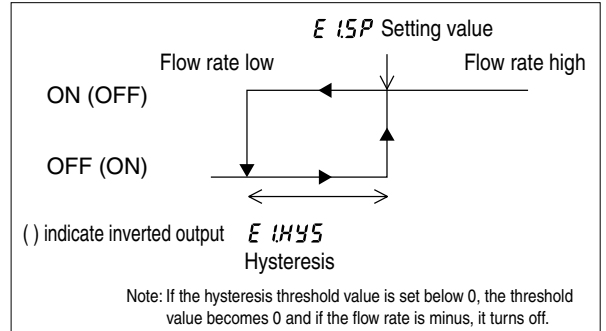

- When function selection **Ⓒ03** is set to **02** or **05** (instantaneous flow rate lower limit switch) After falling below the instantaneous flow rate lower limit value and the switch turns on, the settings for conditions to turn the switch off are set to hysteresis. $[\text{Switch OFF Conditions}] = [\text{Instantaneous Flow Rate Lower Limit Value}] + [\text{Hysteresis}]$ Hysteresis is specified as a percentage (%) of the FS flow rate.

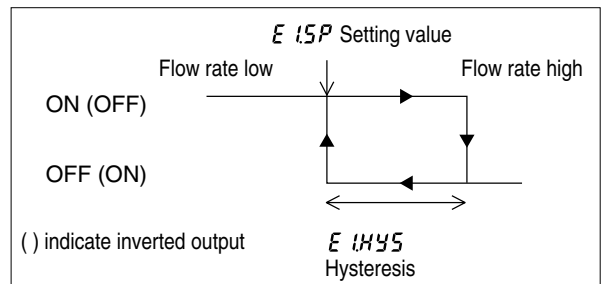

- When function selection **Ⓒ03** is **03** or **06** (instantaneous flow rate range switch) When $E15P > E25P$, the $E15P$ setting value is the upper limit and the $E25P$ setting value is the lower limit. When $E15P < E25P$, the $E15P$ setting value is the lower limit and the $E25P$ setting value is the upper limit. Operation does not work when $E15P = E25P$.

Hysteresis operation can be taken outside of the lower and upper limit setting values as shown below. Hysteresis is specified as a percentage (%) of the FS flow rate. Different settings can be specified for the upper limit value and lower limit value.

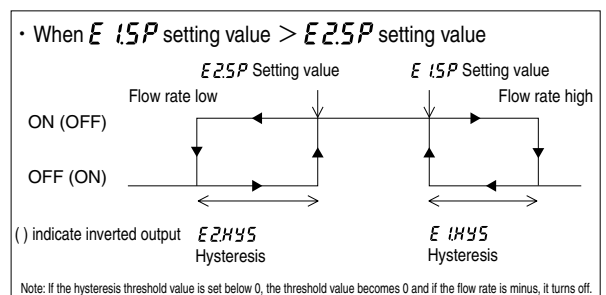
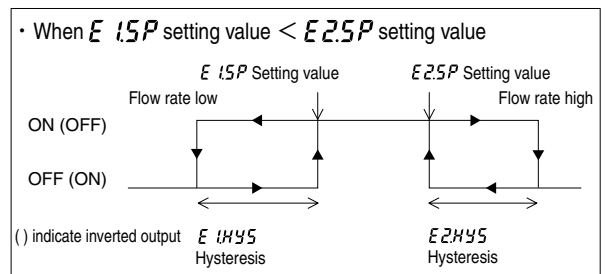

Setup Guidelines

Note 3: Switch on delay operation

Switch on delay specifies the delay time until a switch turns ON.
Switch on delay is enabled when the **E15P** setting is set to **E1dLY**, and the **E25P** setting is set to **E2dLY**.

Note 4: Cost rate

Cost rate is the rate specified in accordance with function selection "**E02**: display unit selection" setting.

E02 selection value	Cost rate setting unit
00: ℓ /min, ℓ	Per 1m ³
01: m ³ /h, m ³	
02: m ³ /min, m ³	
03: kg/h, kg	Per 1 kg

Note 5: Setting ranges

Setting ranges depend on the model number and display unit. The table below shows the available ranges.

E02 Setting value	FAS-002	FAS-005	FAS-030	FAS-060	FAS-120	Remarks
00: [ℓ /min]	0 to 800	0 to 2000	0 to 12000	0 to 24000	0 to 48000	Setting range upper limit is equivalent to a 400% FS flow rate value.
01: [m ³ /h]	0 to 48.0	0 to 120.0	0 to 720.0	0 to 1440.0	0 to 2880.0	
02: [m ³ /min]	0 to 0.800	0 to 2.000	0 to 12.000	0 to 24.000	0 to 48.000	
03: [kg/h]	0 to 62.1	0 to 155.2	0 to 931.0	0 to 1862.0	0 to 3724.0	

If a value that is greater than the maximum display value is set, instantaneous flow rate output will be up to equivalent to the maximum display value.
Do not set values that exceed the maximum display value for instantaneous flow rate switch output 1 and instantaneous flow rate switch output 2. The instantaneous flow rate may not reach the set value during operation in the case.

● Instantaneous flow rate peak value display

- While the instantaneous flow rate screen or integrated flow rate screen is displayed, hold down the **↖** key for about two seconds. This will change to the instantaneous flow rate peak value screen, which alternate between **FLoH I** and the peak value.
- To exit the peak value screen, press the **(mode)** key. This will return to the instantaneous flow rate screen or integrated flow rate screen.
 - To clear the current instantaneous flow rate peak value, display the peak value and then hold down the **↖** key for about five seconds.

● Instantaneous flow rate lower value display

- While the instantaneous flow rate screen or integrated flow rate screen is displayed, hold down the **↙** key for about two seconds. This will change to the instantaneous flow rate lower value screen, which alternate between **FLoLo** and the lower value.
- To exit the lower value screen, press the **(mode)** key. This will return to the instantaneous flow rate screen or integrated flow rate screen.
 - To clear the current instantaneous flow rate lower value, display the lower value and then hold down the **↙** key for about five seconds.

● Information display

- While the instantaneous flow rate screen or integrated flow rate screen is displayed, hold down the **(enter)** key for about two seconds. This will change to the information screen, which alternate between the display item and value.
- To go to the next item, press the **↖** key. To go to the previous item, press the **↙** key.
- To exit the information screen, press the **(mode)** key. This will go to the instantaneous flow rate screen or integrated flow rate screen.

Display content list

Display item	Item content	Description
id_01	Model ID	ID that identifies the model. FAS-002 → 0000 FAS-005 → 0001 FAS-030 → 0002 FAS-060 → 0003 FAS-120 → 0004
id_02	Range ID	ID that identifies the reference range FAS-002 → 02000 (200.0 ℓ /min) FAS-005 → 05000 (500.0 ℓ /min) FAS-030 → 03000 (3000 ℓ /min) FAS-060 → 06000 (6000 ℓ /min) FAS-120 → 12000 (12000 ℓ /min)
id_03	F/W version	
CoSt.L	Cost display (lowest digits)	Shows the cost. ^{Note 1}
CoSt.H	Cost display (highest digits)	
irE.L	Back flow rate integrated value (lowest digits)	Shows the back flow integrated flow rate. ^{Note 2}
irE.H	Back flow rate integrated value (highest digits)	
Itot.L	Cumulative integrated value (lowest digits)	Shows cumulative integrated value since shipment. This value is not returned to 0 by integrated value reset.
Itot.H	Cumulative integrated value (highest digits)	
IPrEL	Integrated value before integrated value reset (lowest digits)	Shows the integrated value immediately before an integrated value reset was performed.
IPrEH	Integrated value before integrated value reset (highest digits)	

- Note 1: The conversion rate can be changed by setting the cost rate setting of parameter setting "**CoSt**".
This item is not displayed when integrated countdown is selected.
- 2: When the function selection "**E12**" integration option is set to **01**, the remaining back flow amount will be displayed and decremented when there is normal flow.

Setup Guidelines

Maintenance mode

The maintenance mode of this product makes it possible to embed adjustment values, to adjust the output circuit, and to configure other special option settings, when replacing the bypass unit.

- While the basic screen is displayed, hold down the (mode) key for about two seconds to enter function selection mode. Next, hold down the (mode) and (enter) keys at the same time for about two seconds.
- Use the (down) and (up) keys to scroll through the setting items and display the one you want. Next, press the (enter) key. This will display a setting value with the rightmost digit flashing.
- Press the (mode) key to move the flashing to the left.

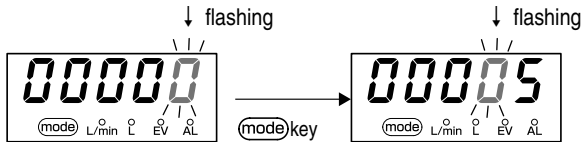

- Use the (down) and (up) keys to change the value of the currently flashing digit. Use the (down) and (up) keys to change each of the digits until the value is the one you want.
- After the setting value is the one you want, press the (enter) key. This will display the setting value so you can check it.
- To configure other settings, repeat steps ② through ⑤.
- To exit the setting procedure, while a setting item is displayed, hold down the (mode) key for about two seconds to return to the basic screen.

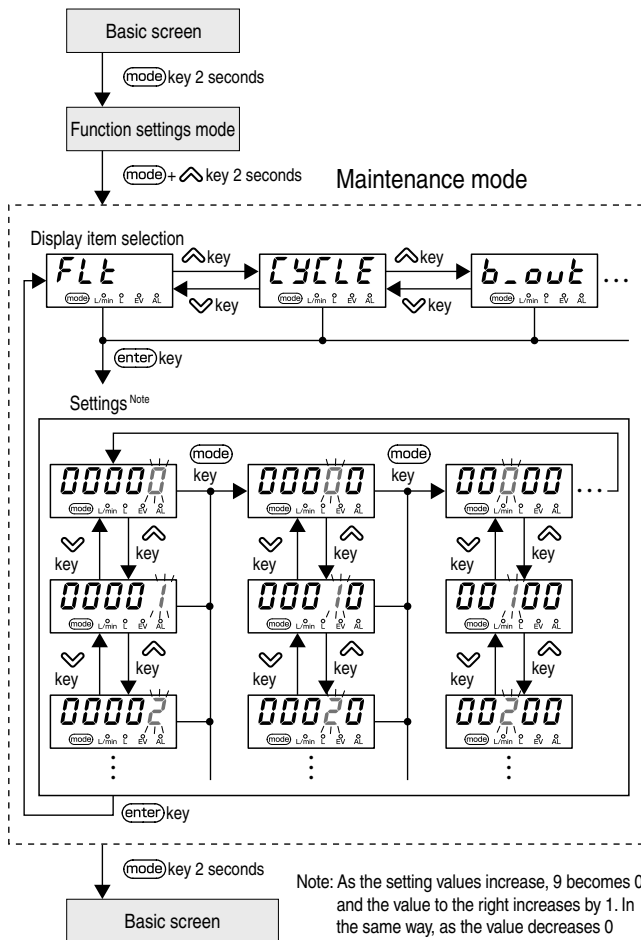

Note: As the setting values increase, 9 becomes 0 and the value to the right increases by 1. In the same way, as the value decreases 0 becomes 9 and the value to the left decreases by 1.

Setting list

Display item	Item content	Setting range	Default	Remarks
FLt	Calculation filter	1 to 16	8	
CYCLE	Measurement cycle	5 to 100	5	[×10ms]
b_out	Fixed output during alarm (Up)	0 to 120%	110	Step of 1
PSCF1	Pressure compensation adjustment value ^{Note}	Adjustment value	0.998	Compensation factor when 01 selected for CLD pressure compensation.
PSCF2	Pressure compensation adjustment value ^{Note}	Adjustment value	1.002	Compensation factor when 02 selected for CLD pressure compensation.
PSCF3	Pressure compensation adjustment value ^{Note}	Adjustment value	1.004	Compensation factor when 03 selected for CLD pressure compensation.
oP0	Channel ID number 0	Adjustment value	***	Configured when using the replacement bypass unit. Settings register main channel characteristic values. Not displayed for FAS-002, FAS-005. Do not change except when replacing bypass unit. Cannot be changed without inputting a password for the PLoDE reservation code.
oP1	Channel ID number 1	Adjustment value	***	
oP2	Channel ID number 2	Adjustment value	***	
54501	Model	FAS-030=2 FAS-060=3 FAS-120=4	***	Configured when using the replacement bypass unit. Note that proper flow rate measurement will not be possible if a different model number from the actual channel is selected. Not displayed for FAS-002, FAS-005. Do not change except when replacing bypass unit. Cannot be changed without inputting a password for the PLoDE reservation code.
PLoDE	Reservation code	***	0	For information about the reservation code, see "Bypass Unit Replacement Guidelines" on page 15.

Note: Certain operating pressures may cause errors in the displayed flow rate when the installation attitude is "Installation attitude 2" (Installation on horizontal piping, display on the right when viewed from the flow meter IN side pipe) or "Installation attitude 3" (Installation on horizontal piping, display on the left when viewed from the flow meter IN side pipe). However, error due to installation attitude can be reduced by setting the pressure compensation adjustment values to the values in the table below. For information about flow rate display change caused by installation attitude, see "Installation attitude" on page 4.

Setting conditions		Setting values	
Display direction	Operating pressure	CLD setting	Maintenance mode setting change
Installation on horizontal piping, display on the right when viewed from the flow meter IN side pipe, Installation attitude 2	0.3 MPa	Set to 01.	Change "PSCF1" to 0.997.
	0.1 MPa	01	Change "PSCF1" to 0.997.
	0.5 MPa	02	Change "PSCF2" to 0.997.
Installation on horizontal piping, display on the left when viewed from the flow meter IN side pipe, Installation attitude 3	0.7 MPa	03	Change "PSCF3" to 0.997.
	0.3 MPa	Set to 01.	Change "PSCF1" to 1.003.
	0.1 MPa	01	Change "PSCF1" to 0.999.
	0.5 MPa	02	Change "PSCF2" to 1.007.
	0.7 MPa	03	Change "PSCF3" to 1.011.

Note: Changing the pressure compensation adjustment value is not required when using an installation attitude other than "Installation Attitude 2" and "Installation Attitude 3".

Maintenance and Troubleshooting

Maintenance

To ensure proper operation, conduct periodic inspection at least once a year. If the self-diagnostic function displays an alarm that does not clear even though the cause of the alarm is eliminated, request servicing from Koganei. Contact the Overseas Department for more information.

The addresses and telephone numbers are shown at the back of this manual.

Troubleshooting

Abnormalities and remedies

Symptom	Remedy
Nothing appears on the display.	<ul style="list-style-type: none"> •Make sure the supply power voltage and polarity are being applied correctly. •Make sure that connectors are connected correctly.
The flow rate display does not become zero even when valves upstream or downstream from the flow meter is closed and there is no flow. (Output signal is not 4 mA.)	<ul style="list-style-type: none"> •Make sure there are no air leaks in the piping. •Make sure that wiring is correct. •When the flow meter is installed on horizontal piping with the display sideways, influence of the installation attitude may cause zero point drift. (Since installation on horizontal piping with the display sideways causes the accuracy guarantee flow rate range to become 5 to 100% FS, set the low flow cut in this case to 5%.) •In a location subject to large ambient temperature fluctuation and large flow fluid temperature fluctuation, convection within the piping may be detected as flow. Perform measurement after temperature has stabilized sufficiently.
Large instrument error compared against the standard instrument. The instrument is outside the accuracy range.	<ul style="list-style-type: none"> •Make sure there are no air leaks in the piping. •Check for foreign matter trapped in the main channel orifice. If foreign matter is present, remove it. •Check for dirt, oil, or other foreign matter in piping and the flow meter connection port. If foreign matter is present, Koganei servicing and replacement are required. Contact your nearest Koganei sales office or the Overseas Department. •Check to make sure that wiring is correct. •Check to make sure that there is no large fluctuation in flow rate within a few seconds and that the measurement range is not exceeded by a large amount.

Alarm displays and required actions

Alarm Code	Item	Description	Cause	Remedy
AL40	Flow rate over	A flow rate that exceeds the value set by the maximum display value parameter setting is flowing. Or a back flow that exceeds the back flow rate range is flowing.	There may be a high flow rate or back flow outside of the maximum display range. <small>Note 1</small>	Check if a high flow rate exists and eliminate its cause. If the instantaneous flow display when the alarm occurs shows a minus (-) sign, back flow occurs. Eliminate the cause of the back flow. The alarm will cease displaying when the actual flow rate becomes within the display range flow rate.
AL51	Registration data abnormality 1	Abnormal channel ID numbers registered. Correct flow rate calculation cannot be performed.	The registered channel ID numbers may be wrong.	Use maintenance mode to register the correct channel ID numbers. <small>Note 2</small> If changing the setting does not clear the alarm, turn the instrument off and then back on again. If this does not clear the alarm, request servicing.
AL52	Registration data abnormality 2	Correct calculation cannot be performed because of abnormal data registered for the flow sensor characteristic values.	Registered characteristic data may be corrupted, resulting in abnormal values.	Turn the instrument off and then back on again. If this does not clear the alarm, request servicing.
ALB1	Sensor abnormality 1	Flow rate signal is outside the proper range.	The signal level may be exceedingly low due to a short circuit caused by adherence of foreign matter or excessive back flow that exceeds the measurement range.	If excessive back flow is the cause, this error will clear automatically when the flow rate returns within the measurement range. If it is not due to excessive back flow and the alarm does not clear after a number of hours, request servicing.
ALB2	Sensor abnormality 2	Flow rate signal level may not match the actual flow rate.	Sensor may be malfunctioning or output may be dropping. Foreign matter may be adhering to sensor, or there may be condensation on the sensor, etc.	Pass dry air through the system. If the error does not clear after a number of hours, request servicing.
ALB3	Sensor abnormality 3			
ALB4	Sensor abnormality 4	Heater voltage is outside the proper range.	The sensor may be damaged, or there may be a short circuit due to the adherence of foreign matter, etc.	If the error does not clear after a number of hours, request servicing.
AL91	Memory abnormality	Instrument information data abnormality	Sum mismatch when accessing EEPROM.	Data may have been corrupted by noise, etc.
AL92		Characteristic value information data abnormality		
AL93		Setting information data abnormality		
AL94		Integrated information data abnormality		
			Power was cut off during data writing, which created the risk of abnormal completion.	Reconfigure the data, and then turn the instrument off and then back on again. If this does not eliminate the alarm, request servicing. Perform an integrated value reset, and then turn the instrument off and then back on again. If this does not eliminate the alarm, request servicing.

Note 1: If parameter setting were used to change the maximum display value, this alarm occurs in accordance with the changed setting.

Note 2: For information about channel ID numbers, see "Bypass Unit Replacement Guidelines" on page 15.

Bypass Unit Replacement Guidelines

CAUTION ● The following modes support bypass unit replacement: FAS-030, -060, and -120.

- Do not lift or carry the flow meter by holding the bypass unit. Doing so can damage the flow meter or cause it to fall, creating the risk of personal injury.
- When replacing the bypass unit, be sure to release flow meter internal pressure before removing the current bypass unit.
- Replacing the bypass unit causes the $\pm 3\%$ FS ± 1 digit instantaneous flow rate display accuracy to become $\pm 5\%$ FS ± 1 digit.

Removing the bypass unit

1. Prepare the following items: Safety glasses, helmet, gloves, hex key (for M5, between flats 4 mm)^{Note 1}
2. Release the pressure from inside the flow meter and piping, use a pressure gauge to confirm that pressure is zero.
3. Gradually loosen the four bolts that secure the bypass unit in place and then remove them.^{Note 2}

Note 1: For safety, wear safety glasses when removing the bypass unit.
 Note 2: Be sure to leave the gasket in place on the main channel.

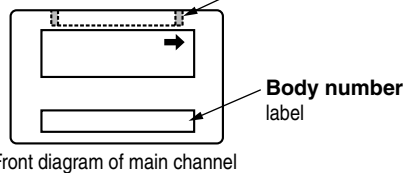
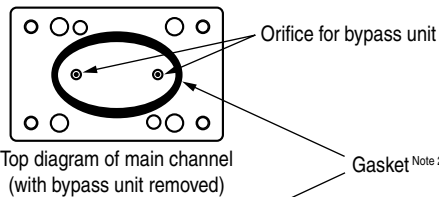
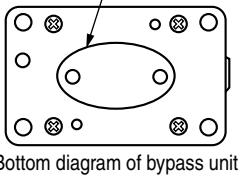
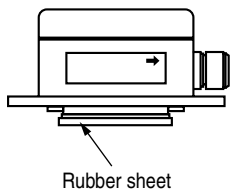

Mounting the bypass unit

1. Check to make sure that the rubber sheet of the new bypass unit is securely affixed and that the gasket that was in place when you purchased the unit is affixed to the main channel. With the arrow on the label of the bypass unit aligned with the arrow on the label of the main channel, mount the bypass unit on the main channel with four bolts. Be sure to tighten the bolts evenly to a tightening torque of 2.6 to 3.3 N·m.
2. Connect the cables and turn on power. Keep the tightening torque of the cable nut to 0.4 to 0.6 N·m range.
3. From the basic screen, enter maintenance mode. Input channel ID numbers for 0, 1, and 2, and input the model number. For details, see "Maintenance Mode" on page 13. If the new replacement bypass unit remains locked, normally the setting lock of the channel ID numbers and model number are disengaged, input 1111 for the P_Code reservation code in the case.
 - The channel ID numbers are marked on the **Body Number** label of the main channel.

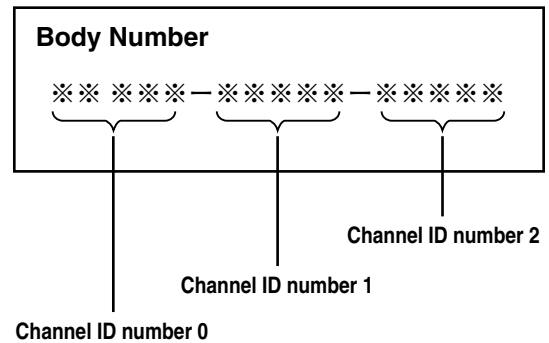

- Model numbers are 2 for the FAS-030, 3 for the FAS-060, and 4 for the FAS-120.
- Be sure to double check the channel ID numbers and the model number after you input them.

4. Check to make sure that the instantaneous flow rate display shows zero.
5. Apply pressure to the flow meter and inside the piping, and check to make sure that the instantaneous flow rate shows zero when there is no flow.
6. Be sure to check and make sure there are no external leaks.

Reference: Channel ID numbers

"Channel ID numbers" are main channel characteristic information that represent main channel's split flow ratio adjustment values. Channel ID numbers 0, 1, and 2 correspond to bypass flow ratio adjustment values 0, 1, and 2. Using maintenance mode to write these values into the bypass unit adjusts output to match the characteristics of each main channel, which makes it possible to maintain accuracy even if the bypass unit is replaced.

Specifications

Item	Model	FAS-002	FAS-005	FAS-030	FAS-060	FAS-120
Medium		Air, nitrogen (However, dry air that does not include any corrosive elements (chlorine, sulfur, acid, etc.), and clean air that does not include dust or oil mist)				
Port size		Rc 1/4	Rc 1/2	Rc1	Rc1 1/2	Rc2
Measurement flow rate range ^{Note 6}		4 to 200	10 to 500	60 to 3000	120 to 6000	240 to 12000
	ℓ /min (normal)	(10 to 200)	(25 to 500)	(150 to 3000)	(300 to 6000)	(600 to 12000)
Minimum sensitivity	ℓ /min (normal)	2	5	30	60	120
Maximum flow rate range	ℓ /min (normal)	−60 to 400	−150 to 1000	−900 to 6000	−1800 to 12000	−3600 to 24000
Display resolution ^{Note 5}	Instantaneous flow rate	1	1	5	10	10
	Integrated flow rate	10	10	10	100	100
Maximum display range	ℓ /min (normal)	−60 to 400	−150 to 1000	−900 to 6000	−1800 to 12000	−3600 to 24000
	m ³ /h (normal)	−3.6 to 24.0	−9.0 to 60.0	−54.0 to 360	−108.0 to 720.0	−220.0 to 1440.0
	m ³ /min (normal)	−0.060 to 0.400	−0.150 to 1.000	−0.900 to 6.000	−1.800 to 12.000	−3.600 to 24.000
	kg/h	−4.7 to 31.0	−11.6 to 77.6	−70 to 465.5	−140.0 to 931.0	−279.0 to 1862.0
Instantaneous flow rate display accuracy		±3% FS ±1 digit (2 to 100% of FS flow rate, 5 to 100% in the case of installation attitudes 2 and 3) ^{Note 9} On the order of ±6% FS (−30 to 0% of FS flow rate) On the order of ±10% RD (100 to 200% of FS flow rate) ^{Note 7}				
Instantaneous flow rate display repeatability		±1.0% FS ±1 digit (2 to 100% of FS flow rate) On the order of ±2% FS (−30 to 0% of FS flow rate) On the order of ±10% RD (100 to 200% of FS flow rate) ^{Note 7}				
Temperature characteristics		No more than 0.15% FS/°C ±1 digit				
Pressure characteristics	Operating pressure 0 to 1MPa	No more than −0.25% FS/0.1 MPa ±1 digit (2 to 40% of FS flow rate) No more than −0.55% FS/0.1 MPa ±1 digit (40 to 100% of FS flow rate)				
	Operating pressure −0.07 to 0 MPa	No more than ±0.25% FS/0.01 MPa ±1 digit (2 to 40% of FS flow rate) No more than ±0.55% FS/0.01 MPa ±1 digit (40 to 100% of FS flow rate)				
Instantaneous flow rate display Change amount ^{Note 8} at installation attitude 2	Operating pressure 0 to 1MPa	No more than 0.5% FS/0.1 MPa ±1 digit (5 to 100% of FS flow rate)				
	Operating pressure −0.07 to 0 MPa	No more than 0.5% FS/0.01 MPa ±1 digit (5 to 100% of FS flow rate)				
Instantaneous flow rate display Change amount ^{Note 8} at installation attitude 3	Operating pressure 0 to 1 MPa	No more than −0.5% FS/0.1 MPa ±1 digit (5 to 100% of FS flow)				
	Operating pressure −0.07 to 0 MPa	No more than −0.5% FS/0.01 MPa ±1 digit (5 to 100% of FS flow)				
Operating pressure range		−0.07 to 1.0 MPa (gauge pressure)				
Operating temperature range		−10 to +60°C (non-freezing)				
Operating humidity range		0 to 90% RH (Non-condensation)				
Storage temperature range		−20 to +70°C (non-freezing)				
Storage humidity range		0 to 90% RH (Non-condensation)				
Proof pressure		1.5 MPa (gauge pressure)				
External leakage amount		100 mL/h (normal) (when flow meter internal pressure is 1.5 MPa)				
Rated voltage		24VDC				
Power supply voltage range		22.8 to 25.2VDC				
Consumption current		120 mA max.				
Calculation cycle		50±5 ms (when shipped)				
Instantaneous flow rate output ^{Note 10}		1 current output: 4 to 20 mA (Output range: 3.2 to 20.8 mA) Fixed output during alarm (up): 21.6 ±0.4 mA (initial default, modifiable by setting) Fixed output during alarm (down): 0.0 ±0.4 mA fixed Allowable load resistance: 300 Ω max. Maximum output current: 24 mA max.				
Response time		Within 1.5 s (For 0 → 100% FS step input, time to reach 95% of maximum value, Calculation cycle: 50 ms)				
Switch output ^{Note 11}		1 open collector output: 30VDC, 50 mA max. One of the following functions can be selected. • Instantaneous flow rate upper limit, lower limit, range • Integrated flow rate countup, countdown • Alarm generation • Integrated pulse output (selection of three pulse weights)				

Specifications

Item	Model	FAS-002	FAS-005	FAS-030	FAS-060	FAS-120
Data recording		Semiconductor non-volatile memory EEPROM Recorded data: Function settings, parameters, integrated values, etc.				
Dielectric strength		Current leakage: No more than 1 mA 500 VAC applied for one second between connector pin and main channel or mounting bolts.				
Insulation resistance		50 MΩ min. Between connector pin and main channel or mounting bolts by 500VDC megger				
Cable		Option (with connector, oil resistant, flame retardant cable UL2464 standard)				
Installation attitude		See "Installation attitudes" on page 4.				
Protective structure		IP65 (JISC0920 and IEC529) water-resistant and dust-resistant construction assuming indoor installation.				
Gas contact portion material	Main channel	Aluminum alloy (anodized)				
	Bypass unit	SUS304, PBT, H-NBR (hydrogenated nitrile rubber)				
	Gasket	H-NBR (hydrogenated nitrile rubber)				
Bypass unit case material		Modified PPO				
Load mass	kg	0.4	0.4	0.5	0.7	1.1

- Note 1: (normal) is a calculated flow rate value for 0°C 101.325 kPa (abs).
 2: FS flow rate indicates the maximum flow rate of the flow meter range.
 3: RD stands for "reading".
 4: A minus (—) flow rate value indicates a back flow rate (flow in the direction opposite that indicated by the flow meter arrow).
 5: Regardless of the unit of display and, the decimal point position, this indicates resolution from the lowest display digit.
 6: A flow rate inside of parentheses () is for installation attitudes 2 and 3.
 7: This accuracy is a value representing instantaneous flow rate display accuracy along with instantaneous display repeatability.
 8: See the installation attitudes on page 4.
 9: Replacing the bypass unit with a new unit causes instantaneous flow rate display accuracy to become ±5% FS ±1 digit. (FAS-030, FAS-060, FAS-120)
 10: The back flow side cannot output.
 11: Back flow side settings cannot be configured.

Order Codes

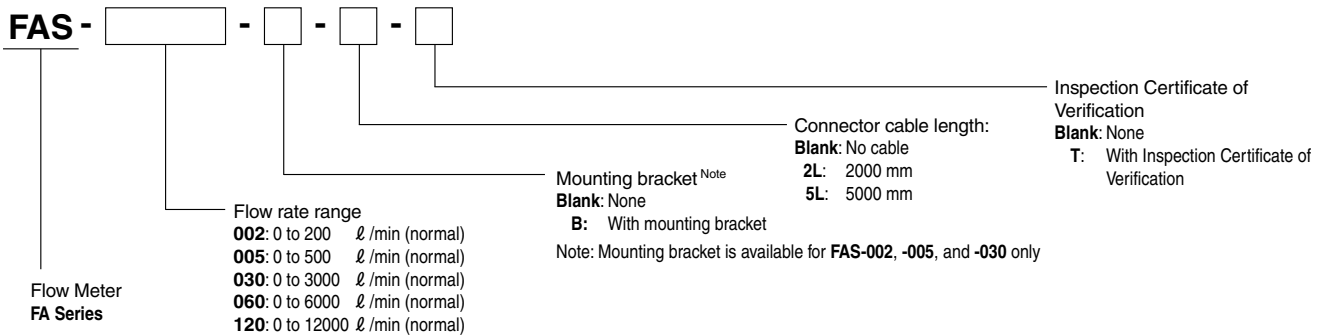

Additional Parts

● **Bypass unit**
 (For use with FAS-030, -060, and -120 only.)

FAB



● **Mounting bracket**
 (For use with FAS-002, -005, and -030 only.)

B-FAS

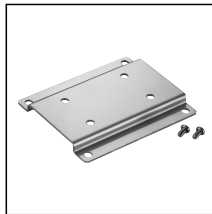

■ **Cable** (Yamatake Corporation)

PA5-41S × 2MK-E (Cable length: 2000 mm)
PA5-41S × 5MK-E (Cable length: 5000 mm)

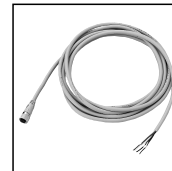

Pressure Loss

● FAS-002

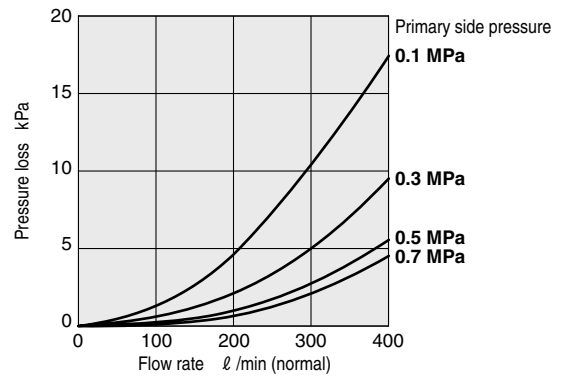
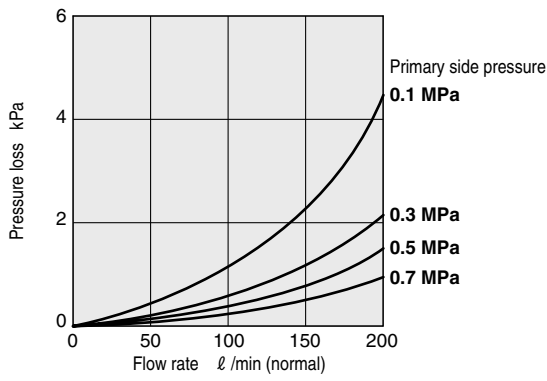

● FAS-005

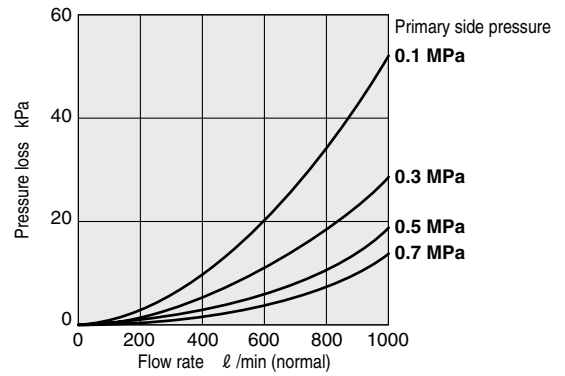
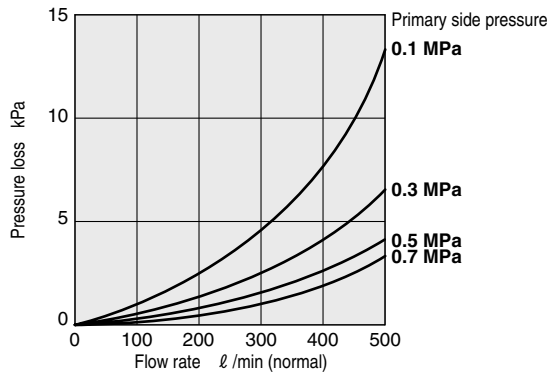

● FAS-030

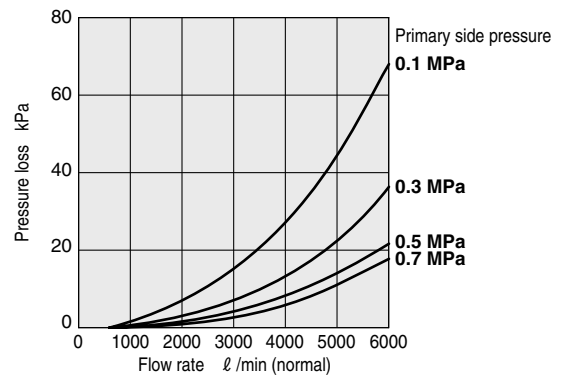
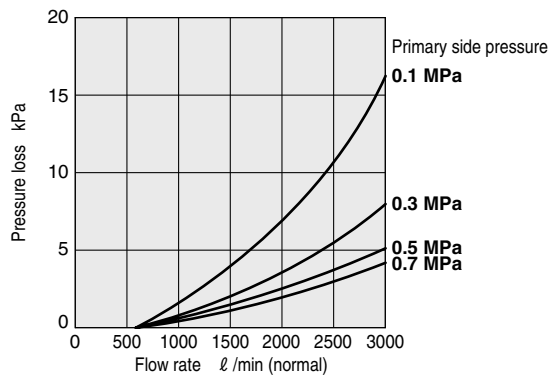

● FAS-060

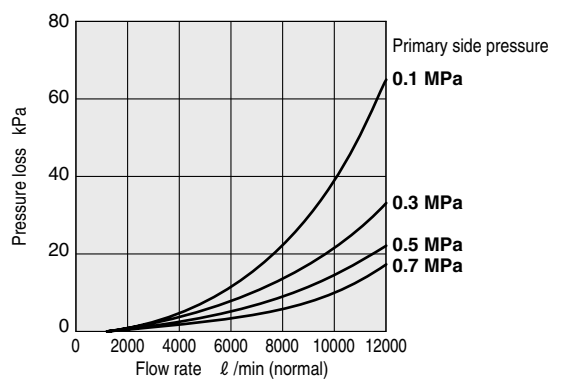
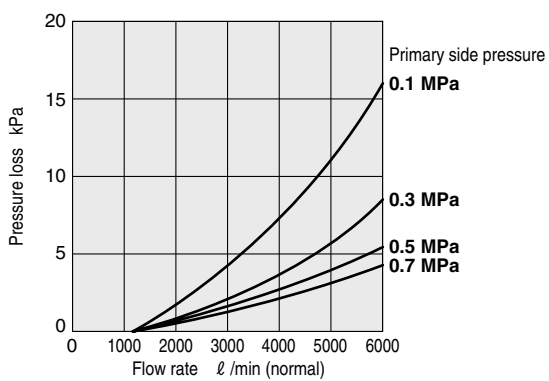

● FAS-120

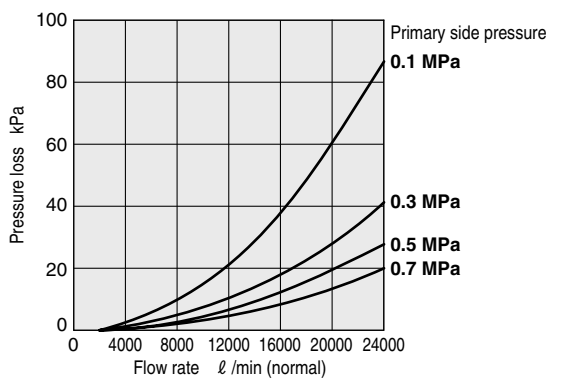
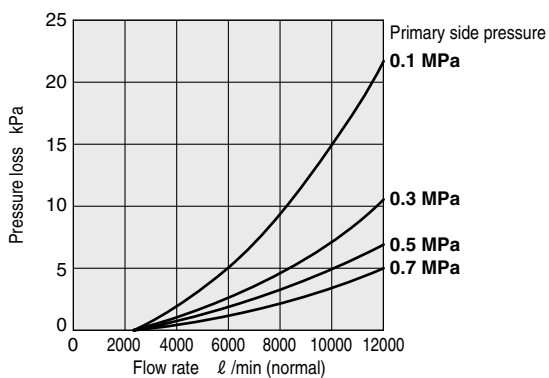

Dimensions (mm)

● FAS-002 · FAS-005

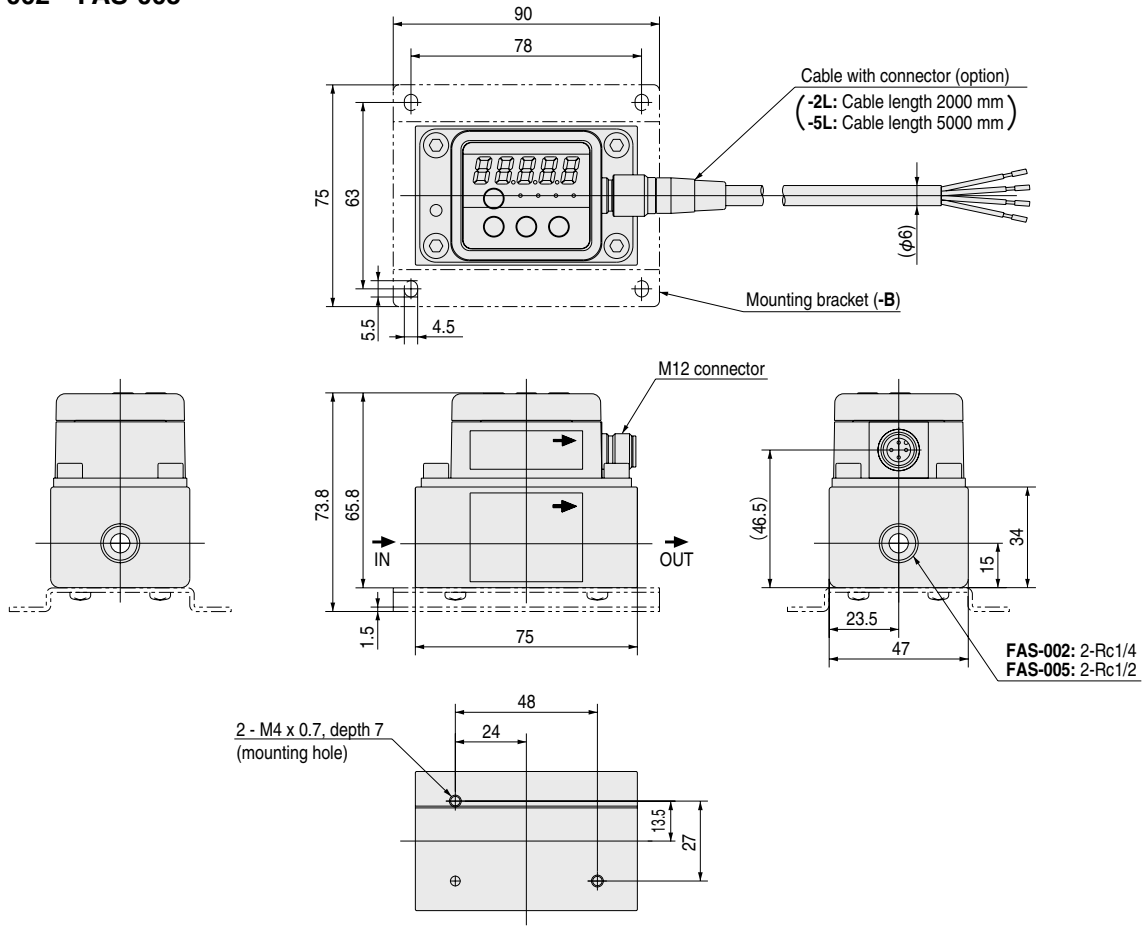

● FAS-030

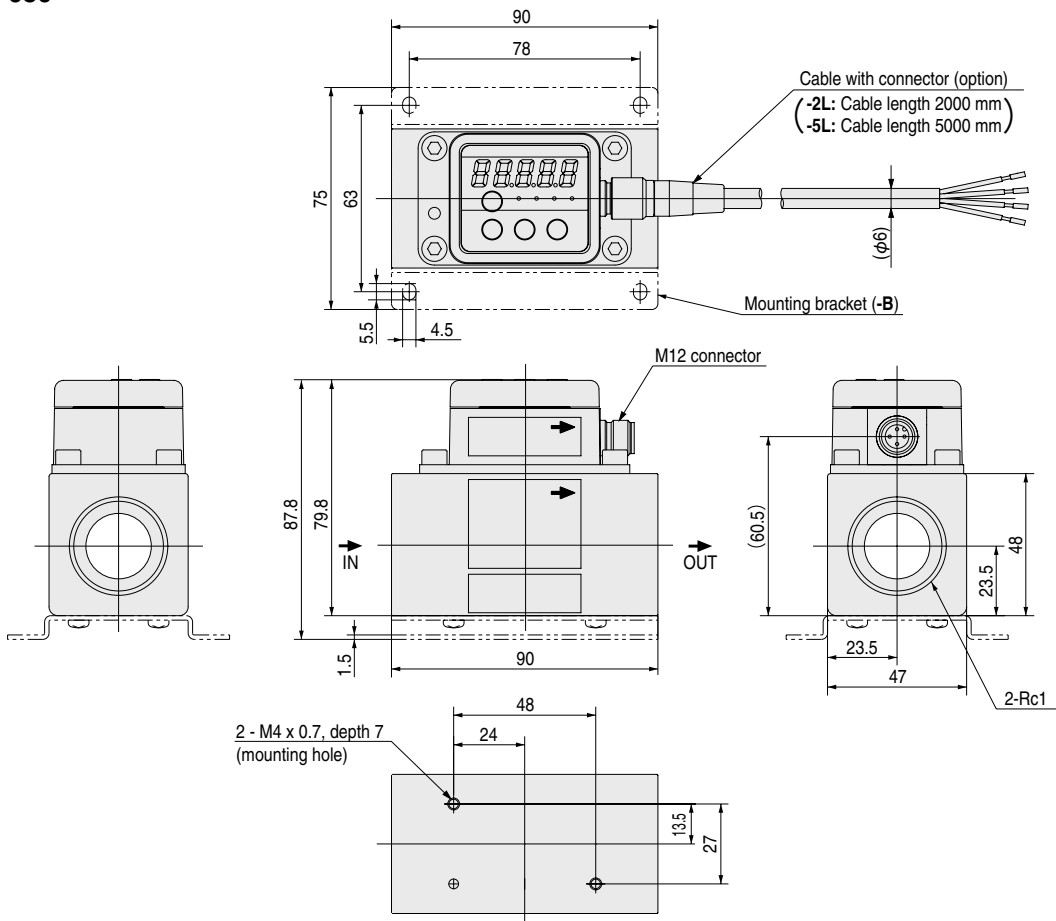

Dimensions (mm)

● FAS-060

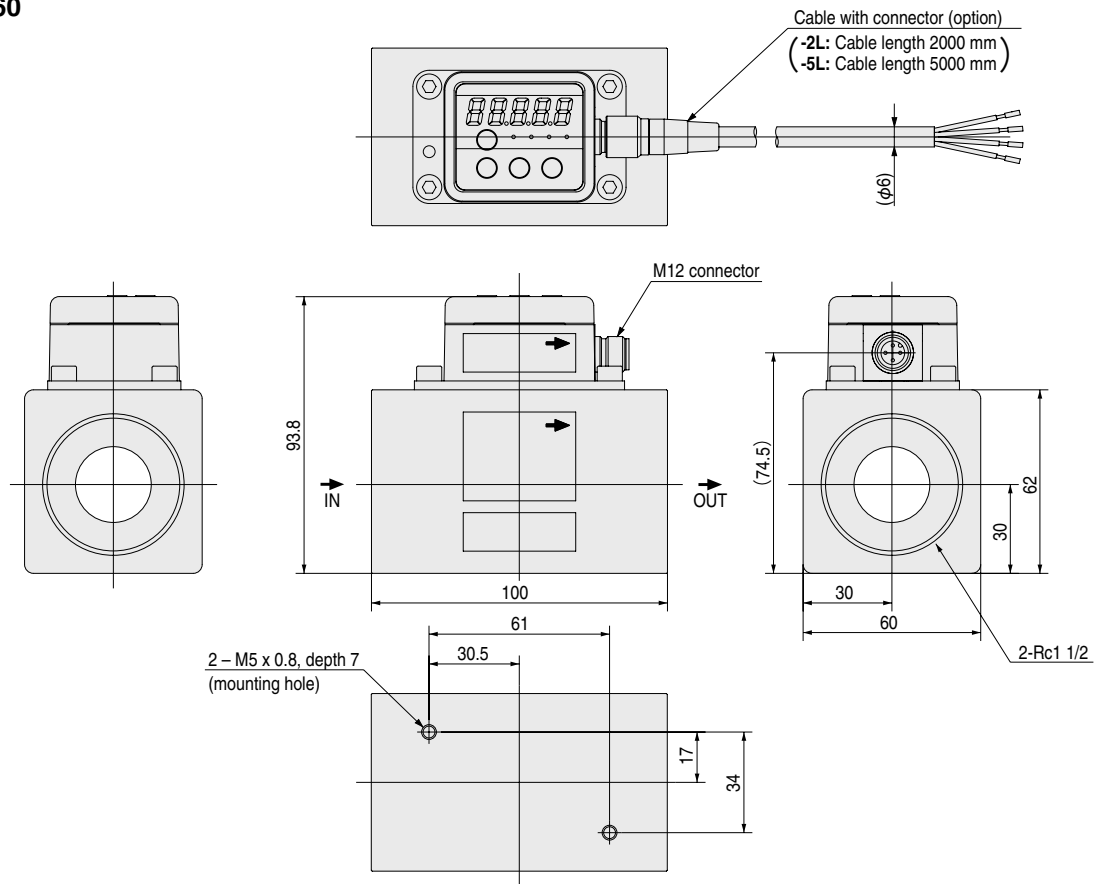

● FAS-120

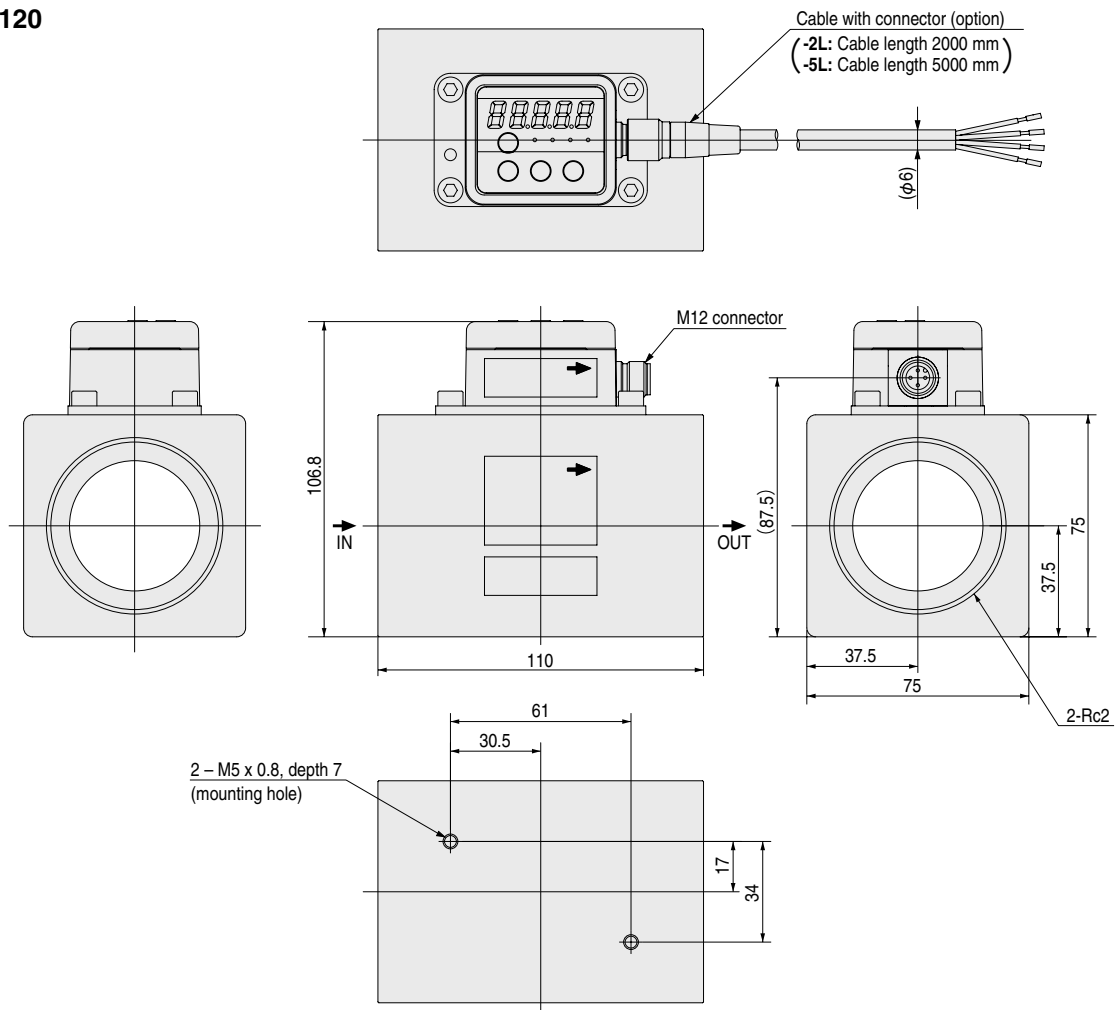

Additional Parts Dimensions (mm)

● **Bypass unit FAB**

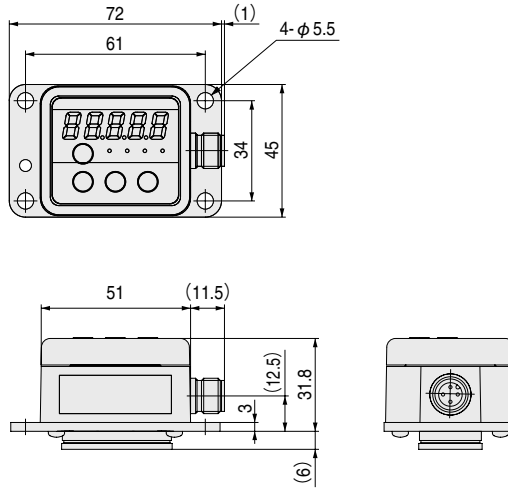

● **Mounting bracket B-FAS**

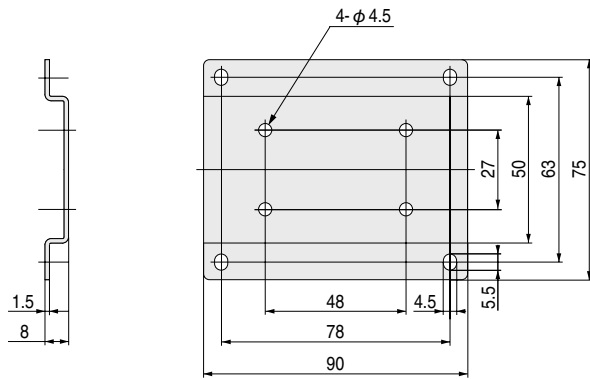

Cross head pan screw
M4 × 0.7 length 6 (2 pcs. supplied)

■ **Cable with connector (option)** **PA5-41S × 2MK-E** (Cable length: 2000 mm)
(Yamatake Corporation) **PA5-41S × 5MK-E** (Cable length: 5000 mm)

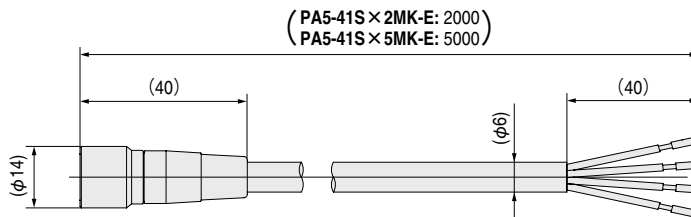

If parts of this document are unclear or you have technical questions, contact the Overseas Department, below.

Inquiries

Koganei Corporation, Overseas Department

3-11-28 Midori-cho, Koganei City, Tokyo 184-8533

TEL: 042-383-7172

FAX: 042-383-7206

FA Series Flow Meter

Detailed Instruction Manual

June 2011 Ver. 1.0 M140787

©Koganei Corporation, Overseas Department

Duplication or transfer of the content of this document in part or
in whole is forbidden.

- For other information and more detailed specifications, see the product catalog.
- For inquiries about the product, contact your nearest Koganei sales office or the Overseas Department noted below.



KOGANEI CORPORATION

OVERSEAS DEPARTMENT

3-11-28, Midori-cho, Koganei City, Tokyo 184-8533, Japan
Tel: 042-383-7271 Fax: 042-383-7276

SHANGHAI KOGANEI INTERNATIONAL TRADING CORPORATION

Room 2606-2607, Tongda Venture Building No. 1, Lane 600,
Tianshan Road, Shanghai, 200051, China
Tel: 021-6145-7313 Fax: 021-6145-7323

KOGANEI-PORNCHAI CO., LTD.

89/174 Moo 3, Vibhavadee Rangsit Road, Talad Bangkhen, Laksi, Bangkok
10210 Thailand
Tel: 02-551-4025 Fax: 02-551-4015

KOGANEI KOREA CO., LTD.

Room #301 Donghwa Bld, 25-5, Yoido, Yongdeunpo-Gu Seoul, Korea
Tel: 02-786-0413 Fax: 02-786-0415