



# KOGANEI

## VALVES GENERAL CATALOG

# SOLENOID VALVES 100 SERIES INDEX

SOLENOID VALVES 100 SERIES

Features	145
Basic Models and Configuration	145
Specifications	147
Solenoid Valve Order Codes	149
Manifold Order Codes	150
Operating Principles and Symbols	151
Dimensions of Solenoid Valve	152
Dimensions of Manifold	153
Handling Instructions and Precautions	156

The standard for square and direct acting types

# Solenoid Valves 100 Series



Offers reliable control of  $\phi 20$  [0.787in.]~  
 $\phi 50$  [1.969in.] bore size air cylinders.  
 Standard direct acting solenoid valve  
 offers a refined inner construction  
 and versatility with excellent reliability  
 and durability, responding with ease of  
 use and flexibility to its “reliable  
 operation” feature.

- The sealing method uses a pressure-balanced poppet for balancing supply pressure at the valve seat portion. Low power consumption translates to optimum performance for high cycle applications, and the valve is compact but large flow.
- An overspring mechanism prevents excessive force from being applied on the seal. It demonstrates excellent durability.
- The single solenoid 2-, 3-, 5-port valves offer assured operations even under low pressure. They demonstrate multiple performance capabilities as a low pressure specification actuator operation, selector valve, or divider valve.
- A flywheel diode is standard equipment for the AC solenoid (optional for the DC24V). Eliminates solenoid burning and humming.
- Responds to diversified needs. Wide selection of options. Units with LED indicators are now simpler than ever.

## 2-, 3-port Valves Valve Functions and Connection Port Configurations

		De-energized	Energized
2-port	Normally closed (NC)		
	Normally open (NO)		
3-port	Normally closed (NC)		
	Normally open (NO)		
Selector valve			
Divider valve			

## 100 Series Single Unit Basic Models and Configuration

2-, 3-port	5-port	
 <b>100E1</b>	2-position Single solenoid  <b>100-4E1</b>	Double solenoid  <b>100-4E2</b>

# 100 Series Manifold Basic Models and Configuration

Manifold for 2-, 3-port valves

**HM□T**—T type (1(P), 3(R) port) manifold



Manifold for combination mounting of 2-, 3-, 5-port valves

**HM□F**—F type (1(P), 3(R2), 5(R1) port) manifold

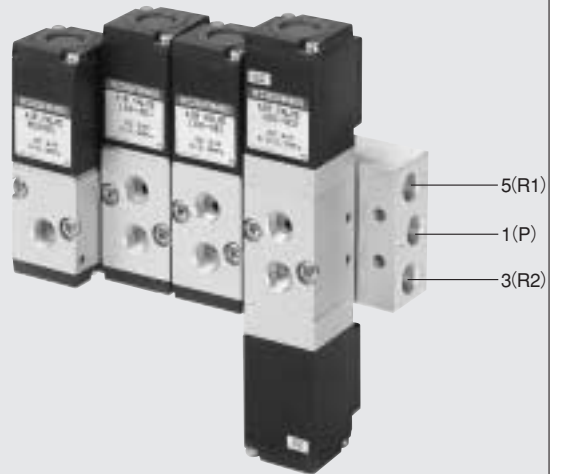

Manifold for combination mounting of 2-, 3-, 5-port valves

**HM□U**—U type (1(P) port) manifold



**HM□L**—L type (1(P) port) manifold



Manifold for 5-port valves only

**HM□A**—A type (all port) manifold

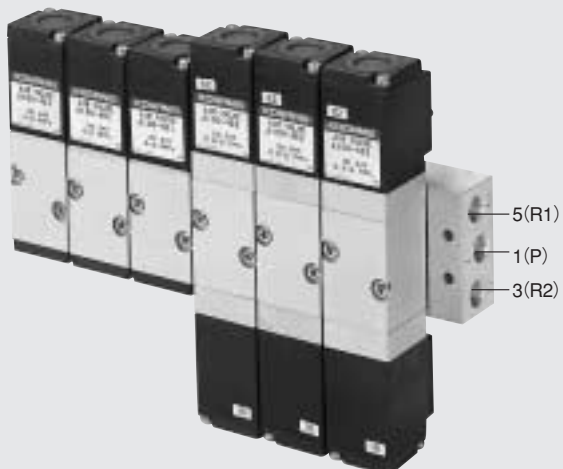

SOLENOID VALVES 100 SERIES

# SOLENOID VALVES

## 100 SERIES

### Basic Models and Functions

Item	Basic model	100E1 (M100E1 <sup>Note</sup> )	100-4E1	100-4E2
		Direct piping, T, F, U, L type manifolds		
	A type manifold	—	A100-4E1	A100-4E2
Number of positions	2 positions			
Number of ports	2, 3 ports		5 ports	
Valve function	Normally closed (NC) or Normally open (NO)		Single solenoid	Double solenoid

Remark: For optional specifications and order codes, see p.149~150.

Note: M100E1 is a dedicated valve for the manifold. For details, see "About M100E1" on p.149.

### Specifications

Item	Basic model	100E1 (M100E1)	100-4E1	100-4E2
		Direct piping, T, F, U, L type manifolds		
	A type manifold	—	A100-4E1	A100-4E2
Media	Air			
Operation type	Direct acting type			
Effective area [Cv]	mm <sup>2</sup>	5.0 [0.28]	3.4 [0.19]	3.0 [0.17]
Port size	Rc1/8			
Lubrication	Not required			
Operating pressure range	MPa(kgf/cm <sup>2</sup> ) [psi.]	0~0.9 {0~9.2} [0~131]		0.2~0.7 {2~7.1} [29~102]
Proof pressure	MPa(kgf/cm <sup>2</sup> ) [psi.]	1.35 {13.8} [196]		1.05 {10.7} [152]
Response time <sup>Note</sup> ms	DC24V	20/20 or below		20 or below
ON/OFF	AC100V, AC200V	20/20 or below		20 or below
Maximum operating frequency	Hz	5		
Minimum time to energize for self holding	ms	—		
Operating temperature range (atmosphere and media) °C [°F]		0~50 [32~122]		5~50 [41~122]
Shock resistance m/s <sup>2</sup> {G}	Lateral direction	1373.0 {140.0}		
	Axial direction	392.3 {40.0}		147.1 {15.0}
Mounting direction	Any			

Note: Values when air pressure is 0.5MPa {5.1 kgf/cm<sup>2</sup>} [73psi.]. Values of double solenoid valves are switching time from the opposite position.

### Solenoid Specifications

Item	Rated voltage	DC24V	AC100V		AC200V	
	Type		DC type	Flywheel diode type		
Operating voltage range	V	21.6~26.4 (24 ± 10%)	90~110 (100 ± 10%)		180~220 (200 ± 10%)	
Current <sup>Note 1</sup> (when rated voltage is applied)	Frequency	—	50	60	50	60
	Energizing <sup>Note 2</sup> mA(r.m.s)	270 (6.5W) {282 (6.8W)}	100 {107}	95 {101}	48 {50}	46 {48}
Maximum allowable leakage current	mA	20	10		5	
Insulation resistance	MΩ	10				
Wiring type and lead wire length	Standard	Grommet type: 300mm [11.8in.]				
	Optional	With DIN connector				
Color of lead wire		Red {Red (+), Blue (-)} <sup>Note 1</sup> Red (+), Black (-) <sup>Note 3</sup>	Yellow, Black		White, Black	
Color of LED indicator (optional)		Red	Yellow		Green	
Surge suppression	Standard	—				
	Optional	Flywheel diode	Flywheel diode <sup>Note 4</sup>			

Notes: 1. Figures in brackets [ ] are for solenoids with LED indicators.

2. Since the AC types have built-in flywheel diodes, the starting current value and energizing current value are virtually the same.

3. For solenoids with surge suppression, and solenoids with surge suppression and LED indicators.

4. Since the AC model has a built-in flywheel diode, they are sometimes not turned on by the solid-state relay (SSR) with zero-cross function.

For this reason, use it only after confirming the solid-state relay's ratings and precautions.

### Manifold Port Size

Manifold model	Port	Location of piping port	Port size
HM□T	1 (P)	Manifold	Rc 1/8
	2 (A)	Valve	
	3 (R)	Manifold	
HM□F	1 (P)	Manifold	Rc 1/8
	4 (A), 2 (B)	Valve	
	3 (R2), 5 (R1)	Manifold	
HM□U	1 (P)	Manifold	Rc 1/8
	4 (A), 2 (B)	Valve	
	3 (R2), 5 (R1)	Valve	
HM□L	1 (P)	Manifold	Rc 1/8
	4 (A), 2 (B)	Valve	
	3 (R2), 5 (R1)	Valve	
HM□A	1 (P)	Manifold	Rc 1/8
	4 (A), 2 (B)		
	3 (R2), 5 (R1)		

### Solenoid Valve Mass

g [oz.]

Basic model	Mass
100E1	190 [6.70]
M100E1	190 [6.70] <sup>Note</sup>
100-4E1	220 [7.76]
100-4E2	400 [14.11]
A100-4E1	230 [8.11]
A100-4E2	410 [14.46]

Note: Sub-plate not included. For sub-plate mass, see p.153.

### Manifold Mass

g [oz.]

Manifold model	Mass calculation of each unit (n=number of units)	Block-off plate
HM□T	$(73 \times n) + 73$ $[(2.57 \times n) + 2.57]$	21 [0.74]
HM□F	$(64 \times n) + 64$ $[(2.26 \times n) + 2.26]$	26 [0.92]
HM□U	$(26 \times n) + 130$ $[(0.92 \times n) + 4.59]$	11 [0.39]
HM□L	$(26 \times n) + 130$ $[(0.92 \times n) + 4.59]$	11 [0.39]
HM□A	$(64 \times n) + 64$ $[(2.26 \times n) + 2.26]$	26 [0.92]

### Cylinder Operating Speed

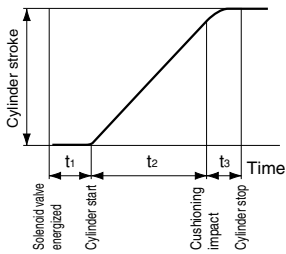

To obtain the time required for the cylinder to complete 1 stroke, add the cylinder's delay time  $t_1$  (time between energizing of the solenoid valve and actual starting of the cylinder), to the cylinder's max. operating speed time  $t_2$ . When a cushion is used, add the cushioning time  $t_3$ , to the above calculations. The standard cushioning time  $t_3$  is approximately 0.2 seconds.

### 100-4E1, 100-4E2

#### Measurement conditions

- Air pressure: 0.5MPa {5.1kgf/cm<sup>2</sup>} [73psi.]
- Piping inner diameter and length:  $\phi 6 \times 600$ mm
- Fitting: Quick fitting TS8-01
- Load ratio =  $\frac{\text{Load}}{\text{Cylinder theoretical thrust}}$  (%)
- Cylinder stroke: 150mm [5.91in.]

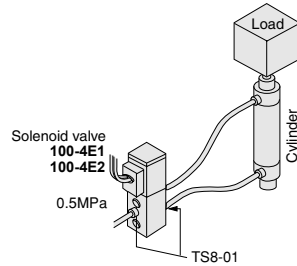

#### Maximum operating speed

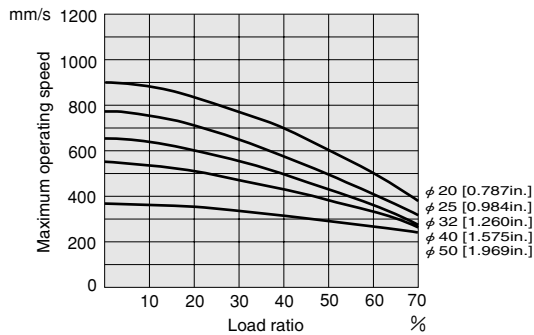

#### Delay time

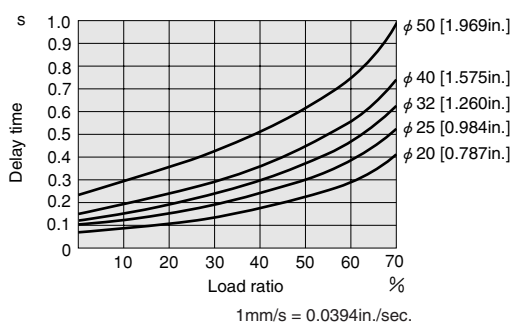

1mm/s = 0.0394in./sec.

### Flow Rate

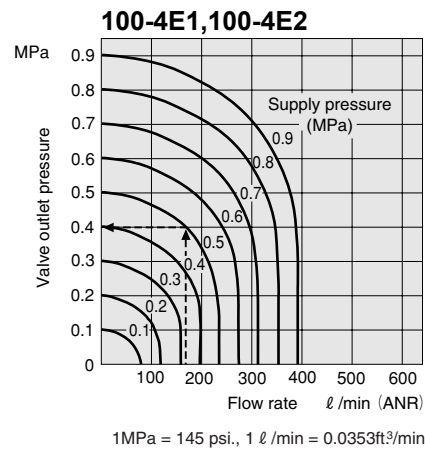
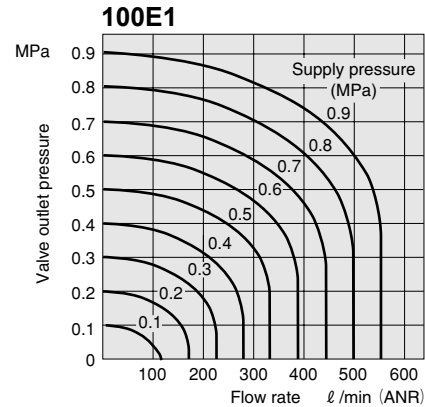







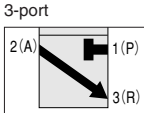
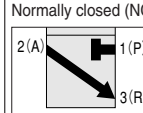

1MPa = 145 psi., 1 l/min = 0.0353ft<sup>3</sup>/min.

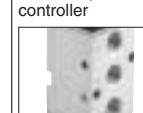
#### How to read the graph

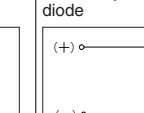
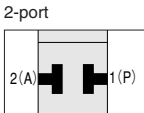
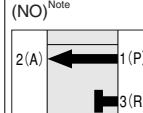
When the supply pressure is 0.5MPa [73psi.] and flow rate is 175 l/min [6.18ft<sup>3</sup>/min.] (ANR), the valve outlet pressure becomes 0.4 MPa [58psi.].

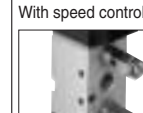
# 100 Series Solenoid Valve Order Codes

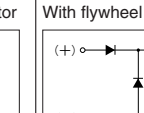
2-, 3-port valve Number of ports	2-, 3-port valve Valve function	Mounting base	Wiring type ●Lead wire length: 300mm [11.8in.] is standard.	Speed controller	Muffler	LED indicator	Flywheel diode					
3-port  Blank	Normally closed (NC)  Blank	Without mounting base  Blank	Grommet type  Blank	Without speed controller  Blank	Without muffler  Blank	Without LED indicator  Blank	Without flywheel diode  Blank					
2-port  -2	Normally open (NO) <sup>Note</sup>  -11	With mounting base  -21	DIN connector  -39	With speed controller  -70	With muffler  -75	With LED indicator  -LF	With flywheel diode  -SR					
		Basic model						Voltage				
Direct piping	2-, 3-port single solenoid	100E1	-2 <sup>Note4</sup>	-11 <sup>Note2</sup>	-21	-39	-70	-75	-LF	-SR	DC12V DC24V AC100V AC200V	
	5-port single solenoid	100-4E1										
	5-port double solenoid	100-4E2										
For manifold only <sup>Note1</sup>	2-, 3-port single solenoid	M100E1	-2	-11				-75 <sup>Note3</sup>				DC12V DC24V AC100V AC200V
	5-port single solenoid	A100-4E1			-39				-LF	-SR		
	5-port double solenoid	A100-4E2										

Notes : 1. Cannot be used as a single unit.

2. For 2-port only. Always enter **100E1-2-11**. For the 3-port, supplying air through the 3(R) port and exhausting through the 1(P) port makes it possible to use as a normally open (NO) type valve.

3. For U, L type manifolds only.

4. A plug is included. Always install it in position before use.

● **M100E1** includes sub-plates for mounting on the F type manifold, gaskets, and mounting screws.

● When ordering the non-ion specification, enter **-NCU** after the basic model code.

● Not available with DIN connector.

● For DC12V, DC24V only. For AC100V and AC200V, equipped as standard.

## Manifold Models and the Applicable Valves Basic Models

Valve specification Manifold model	2-, 3-port		5-port	
	Single solenoid	Single solenoid	Single solenoid	Double solenoid
HM□T	100E1 M100E1-11		—	
HM□F	M100E1 M100E1-11	100-4E1	100-4E2	
HM□U	100E1 M100E1-11	100-4E1	100-4E2	
HM□L				
HM□A		A100-4E1	A100-4E2	

## ● About M100E1

**M100E1** is a dedicated valve for the manifold.

Differences with **100E1** are as shown in the table below:

Model	Point of difference	Remarks
M100E1	With sub-plate <sup>Note</sup>	For F type manifold only
M100E1-11	With sub-plate <sup>Note</sup> Port location	For T, F, U, L type manifolds

Note: The sub-plate is only used for mounting on F type manifolds. For details, see p.153.

# 100 Series Manifold Order Codes

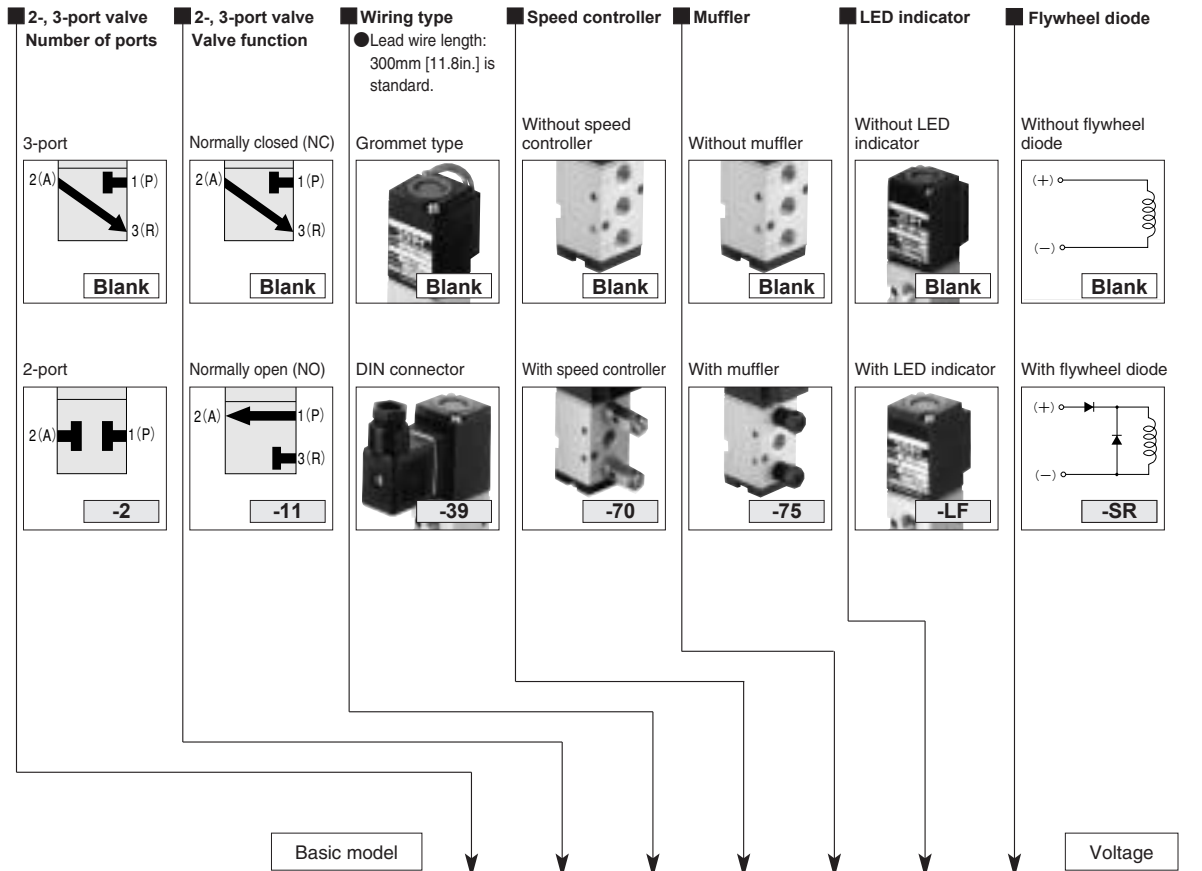

HM	2 : 10	T	stn. <input type="checkbox"/>	-100E1	-2	-11	-39	-LF	-SR	DC12V DC24V AC100V AC200V		
			stn. <input type="checkbox"/>	-M100E1 <sup>Note</sup>								
		F	stn. <input type="checkbox"/>	-M100E1 <sup>Note</sup>	-2	-11	-39	-LF	-SR	DC12V DC24V AC100V AC200V		
			stn. <input type="checkbox"/>	-100-4E1								
			stn. <input type="checkbox"/>	-100-4E2								
		U L	stn. <input type="checkbox"/>	-100E1	-2	-11	-39	-70	-75	-LF	-SR	DC12V DC24V AC100V AC200V
			stn. <input type="checkbox"/>	-M100E1 <sup>Note</sup>								
			stn. <input type="checkbox"/>	-100-4E1								
		A	stn. <input type="checkbox"/>	-A100-4E1			-39			-LF	-SR	DC12V DC24V AC100V AC200V
			stn. <input type="checkbox"/>	-A100-4E2								

Note: **-M100E1** should be used in the normally open type (optional code: **-11**) only.

- Specify the valve model for each station.
- Enter **-BP** when closing a station with a block-off plate without mounting a valve.
- When ordering the non-ion specification, enter **-NCU** after the basic model code.

● For DC12V, DC24V only. For AC100V and AC200V, equipped as standard.

● Not available with DIN connector.

● Valve mounting location from the left-hand side when facing the 4(A), 2(B) ports.

## Options

Mounting base



- For direct piping
- Not available with double solenoid

Speed controller

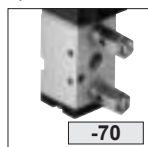

- For direct piping
- Not available with 2-, 3-port

Muffler

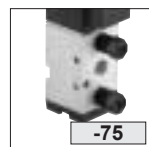

DIN connector



- Cannot be used with -LF

Built-in LED indicator

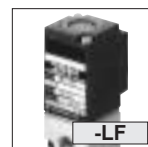

Built-in flywheel diode

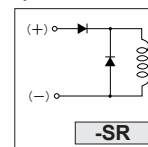

- Only for DC24V

Block-off plate

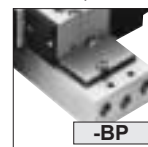

# Operating Principles and Symbols

## 3-port

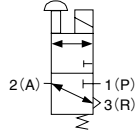

### 100E1

De-energized

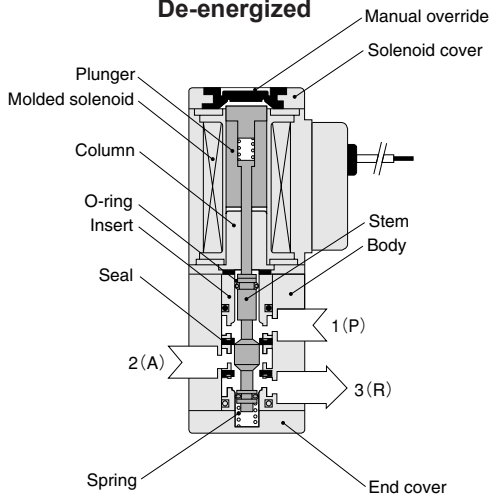

## Major Parts and Materials

	Parts	Materials
Valve	Body	Aluminum alloy (anodized)
	Stem	Stainless steel
	Seal	Synthetic rubber
	Insert	Aluminum alloy and brass
	Spring	Stainless steel
	Mounting base	Mild steel (zinc plated)
	Plunger	Magnetic stainless steel
Manifold	Column	Magnetic steel (zinc plated)
	Body	Aluminum alloy (anodized)
	Block-off plate	Mild steel (zinc plated)
	Seal	Synthetic rubber
	Mounting bracket	Mild steel (zinc plated)

Remark: Materials that generate copper ions are not used for the non-ion specification.

## 5-port

Single solenoid

Double solenoid

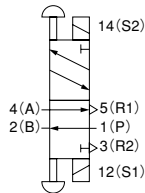
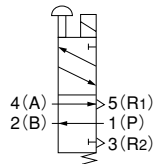

### 100-4E1

De-energized

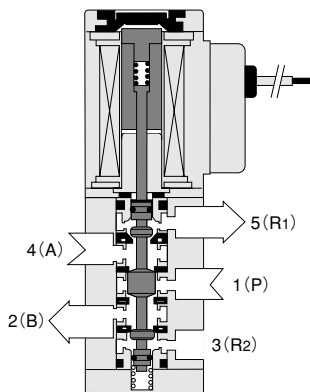

### 100-4E2

(De-energized condition after energizing solenoid 12(S1))

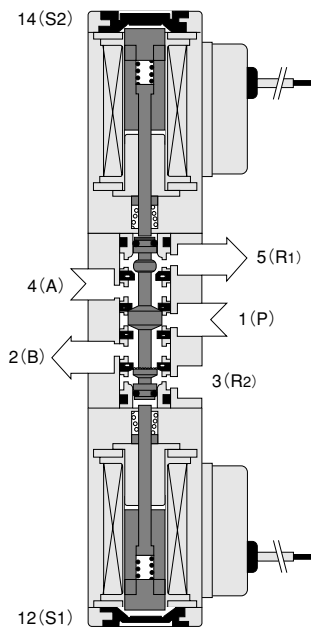



# Dimensions of Solenoid Valve (mm)

## 2-, 3-port

### 100E1

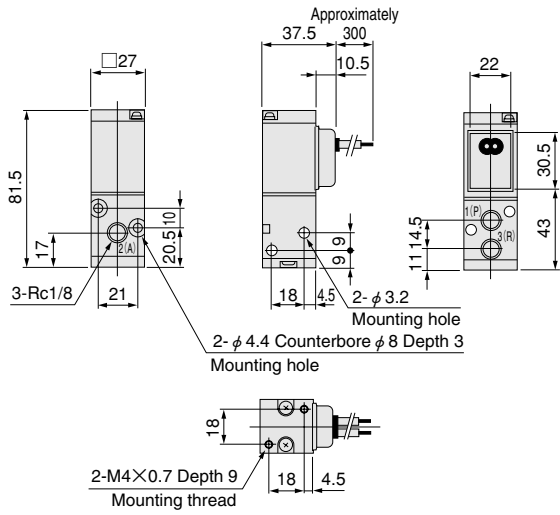

## 5-port

### 100-4E1

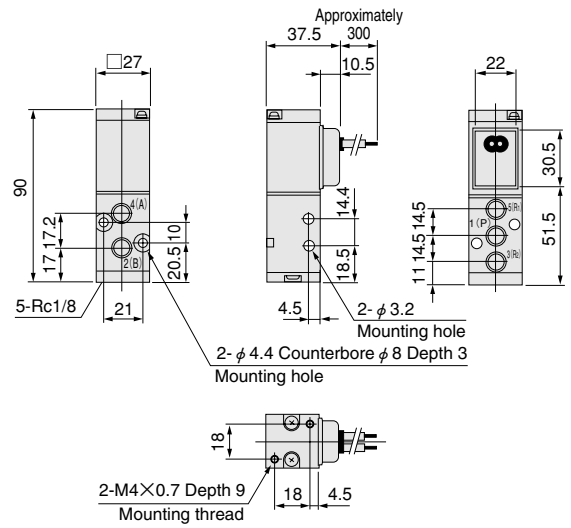

### 100-4E2

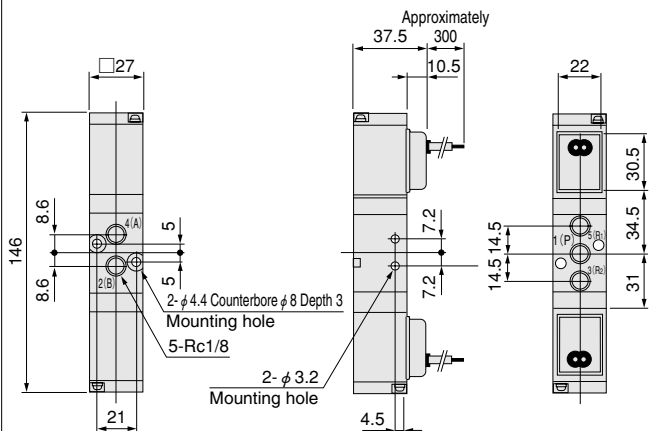

## Options (mm)

● Mounting base: -21

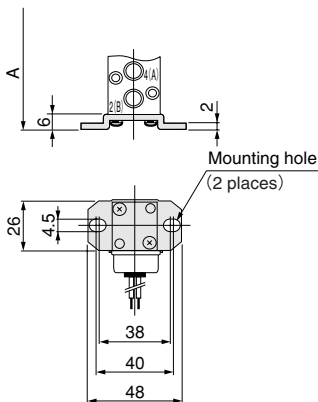

● Solenoid with DIN connector: -39

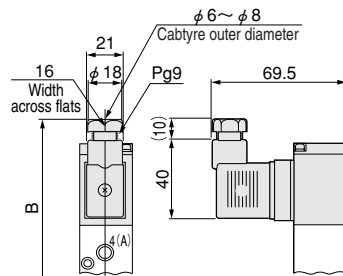

● Solenoid with LED indicator: -LF

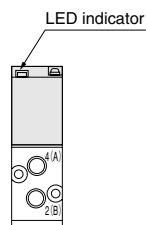

● Speed controller: -70

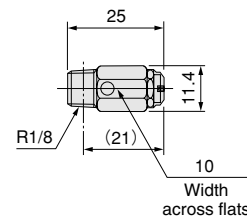

● Muffler: -75

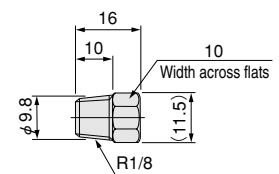

Model	Code	A	B	Remarks
100E1		87.5	94	A: Overall length to the top surface of the valve
100-4E1		96	103	B: Overall length to the bottom of the valve
100-4E2		—	172	Overall length to the end of the opposite side solenoid

# Dimensions of Manifold (mm)

## For 2-, 3-port

HM□T

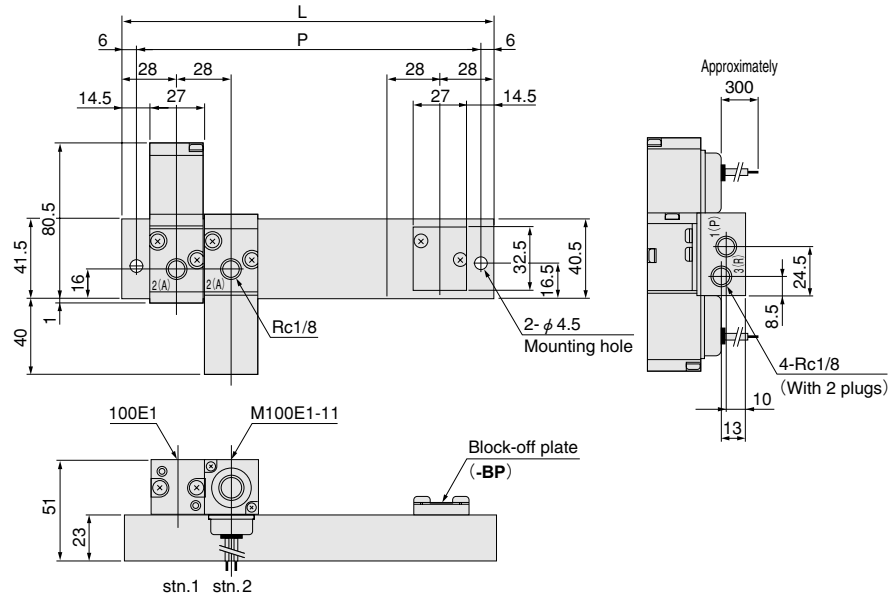

### Unit dimensions

Model	L	P
HM2T	84	72
3T	112	100
4T	140	128
5T	168	156
6T	196	184
7T	224	212
8T	252	240
9T	280	268
10T	308	296

## For combination mounting of 2-, 3-, 5-port

HM□F

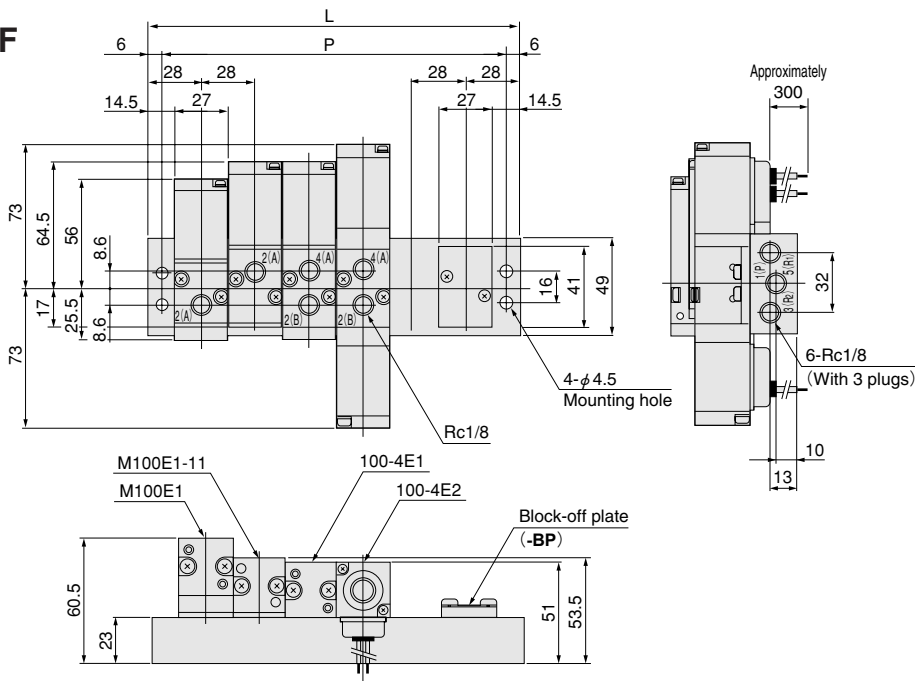

### Unit dimensions

Model	L	P
HM2F	84	72
3F	112	100
4F	140	128
5F	168	156
6F	196	184
7F	224	212
8F	252	240
9F	280	268
10F	308	296

### ● Mounting 2-, 3-port valves on HM□F

#### 1. Mounting normally closed type

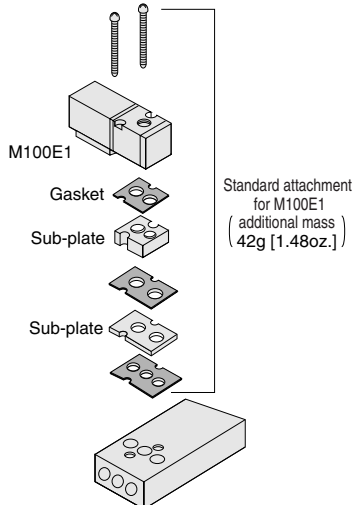

#### 2. Mounting normally open type

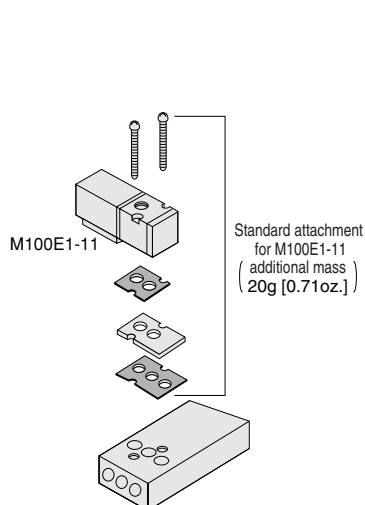

#### 3. Mounting normally closed or normally open with DIN connector

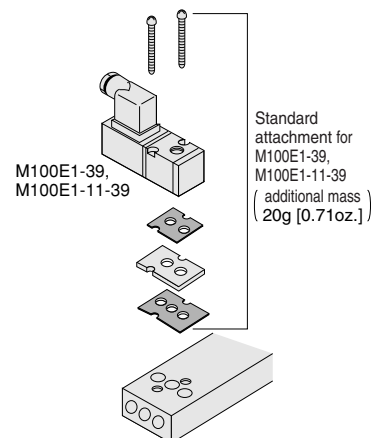

# Dimensions of Manifold (mm)

## For combination mounting of 2-, 3-, 5-port

### HM□U

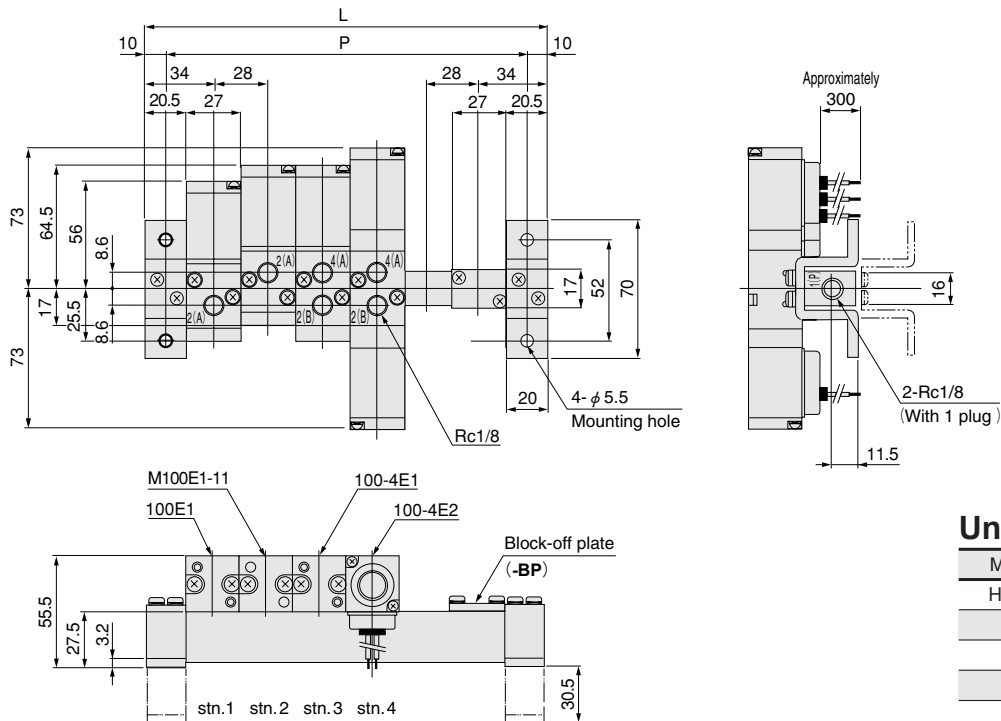

### Unit dimensions

Model	L	P
HM2U	96	76
3U	124	104
4U	152	132
5U	180	160
6U	208	188
7U	236	216
8U	264	244
9U	292	272
10U	320	300

### HM□L

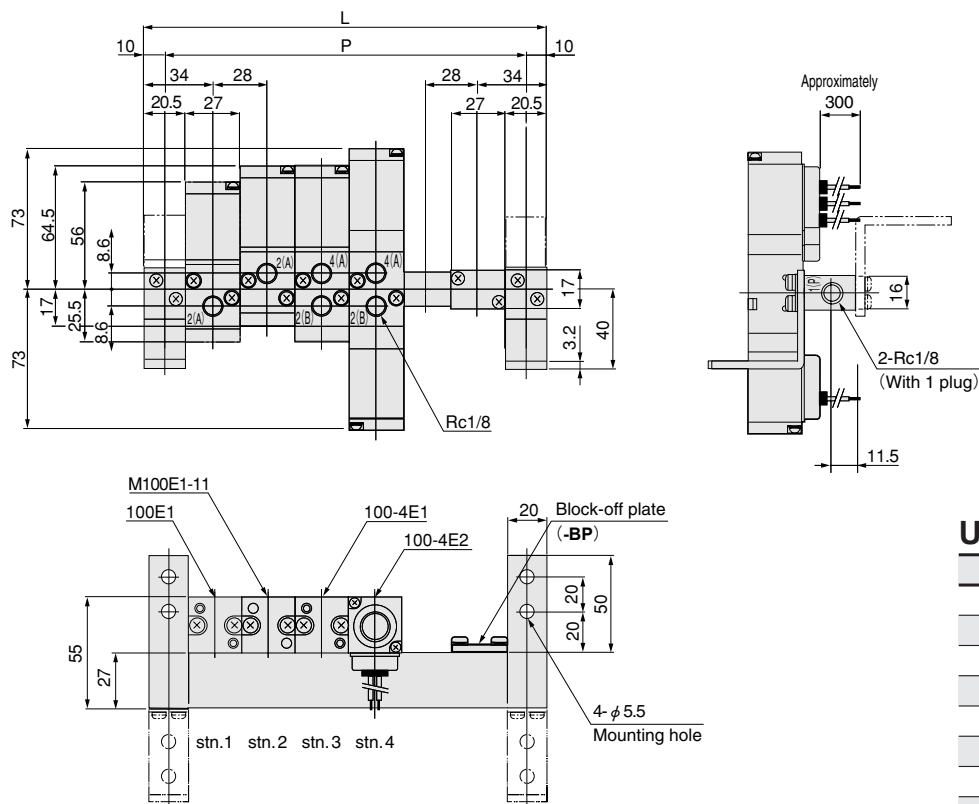

### Unit dimensions

Model	L	P
HM2L	96	76
3L	124	104
4L	152	132
5L	180	160
6L	208	188
7L	236	216
8L	264	244
9L	292	272
10L	320	300

For options, see p.152.

# Dimensions of Manifold (mm)

## For 5-port

HM□A

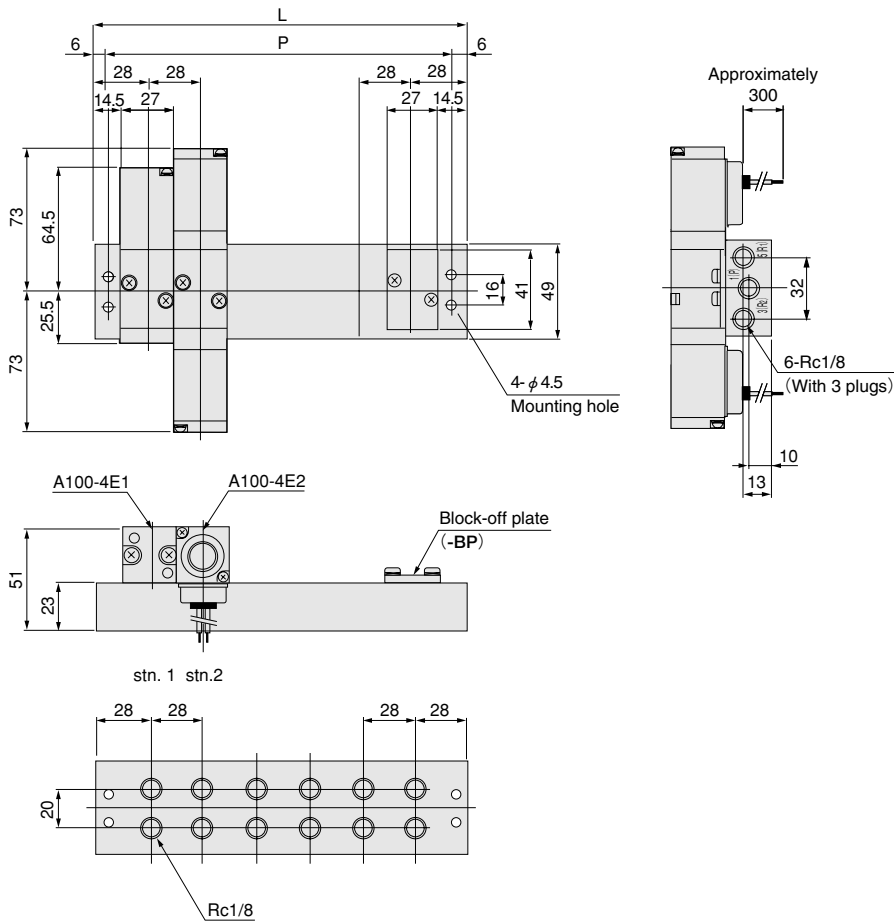

### Unit dimensions

Model	L	P
HM2A	84	72
3A	112	100
4A	140	128
5A	168	156
6A	196	184
7A	224	212
8A	252	240
9A	280	268
10A	308	296

For options, see p.152.

# Handling Instructions and Precautions



## Solenoid

### Internal circuit

#### ●DC24V

##### Standard solenoid

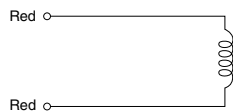

##### Solenoid with LED indicator

##### Order code: -LF

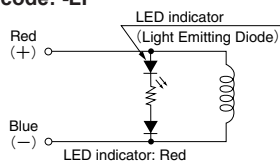

##### Solenoid (Surge suppression)

##### Order code: -SR

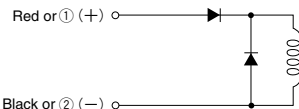

① and ② are for with DIN connector (order code: -39).

##### Solenoid with LED indicator (Surge suppression)

##### Order code: -LF-SR

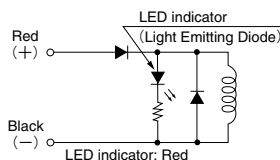

#### ●AC100V, AC200V (Surge suppression)

##### Standard solenoid

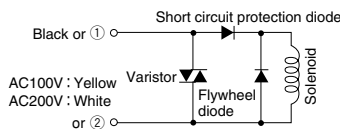

① and ② are for with DIN connector (order code: -39).

##### Solenoid with LED indicator

##### Order code: -LF

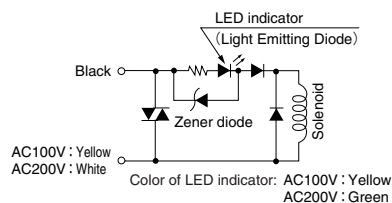

- Cautions:**
1. Do not apply megger between the lead wires.
  2. The DC solenoid will not short circuit even if the wrong polarity is applied, but the valve will not operate.
  3. Leakage current inside the circuit could result in failure of the solenoid valve to return, or in other erratic operation. Always use it within the range of the allowable leakage current. If circuit conditions, etc. cause the leakage current to exceed the maximum allowable leakage current, consult us.
  4. For a double solenoid valve, avoid energizing both solenoids simultaneously. The valve could fall into the neutral position.
  5. Since the AC solenoid uses diodes for the solenoid, always use lead wires of the same color when connecting a number of solenoid units in parallel. The DC24V standard solenoid, however, has no polarity, so either lead wire connection is acceptable.



### Manual override

#### Non-locking type

To operate the manual override, press it all the way down. The single solenoid valve works the same as when in the energized state as long as the manual override is pushed down, and returns to the rest position upon release.

For the double solenoid valve, pressing the manual override on the 12(S1) side switches the 12(S1) to the energized state, and the unit remains in that state even after the manual override is released. To return it to the rest position, operate the manual override on the 14(S2) side. This is the same for the solenoid 14(S2).

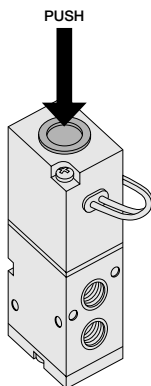

※ Illustration shows the 200 series.

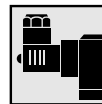

## DIN connector

### Wiring instructions

Remove the cover mounting screws, and lift the terminal cover off from the solenoid. Use a screwdriver (blade width 4~4.5mm [0.16~0.18in.]), etc. to push strongly against the terminal body through the hole of the terminal cover's mounting screw, and remove the terminal body.

Slip a cable gland, washer, and cable gasket over a cable (outer diameter 6~8mm [0.24~0.31in.]), insert the cable into the terminal cover's wiring port, and connect the lead wire to the terminal body (screwdriver blade width of about 3mm [0.12in.]).

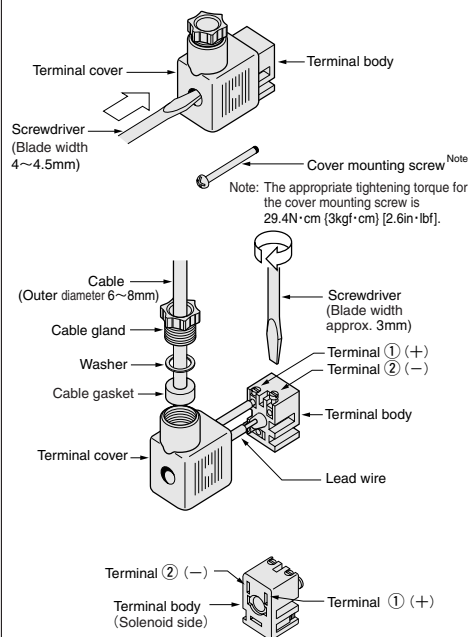

※ For the DC24V solenoid with surge suppression, connect (+) to Terminal ①, and (-) to Terminal ②.