



Electrostatic Potential Sensor

Introducing small sensors perfect for monitoring static electricity in-line!

These sensors can constantly monitor and measure the static electricity on assembly lines, which would be difficult with handheld measuring devices.

The integrated amplifier allows for low cost and total space saving.

Enables electrostatic control on production line

Constant monitoring of invisible static electricity can be performed without expending manhours on electrostatic measurement or controls.

Electrostatic controls through constant monitoring can be performed in measurement locations difficult to reach with handy-type measuring instruments.

2 output types

These sensors are provided with an output type that can do analog output, and a switch output type that can do judgment output.

Judgment output function (switch output type only)

If a judgement threshold is set, notification is made by a sensor LED and voltage comparison output (judgment output).

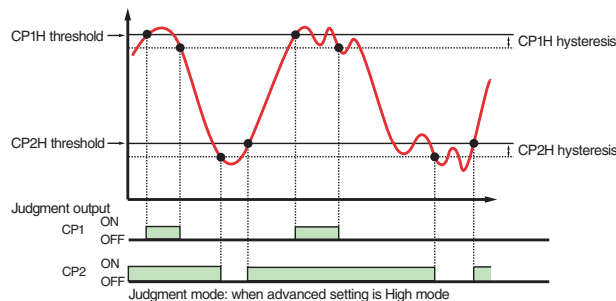

Three operation mode patterns are available

Selectable from the standard mode, high voltage mode, and ion balance monitor mode.

- **Standard mode**
Measurement distance of 6 to 15 mm [0.236 to 0.591 in], ± 1000 V range
16 to 100 mm [0.630 to 3.9 in], ± 2000 V range
- **High voltage mode**
Measurement distance of 6 to 15 mm [0.236 to 0.591 in], ± 10.00 kV range
16 to 100 mm [0.630 to 3.9 in], ± 20.00 kV range
- **Ion balance monitor mode**
Measures the ion balance of the ionizer.

With zero calibration function switch

The zero calibration function can be used to adjust the current measured value to 0V. (Settings can be done within a -200 V \leq measured value \leq $+200$ V range. Input and communication can be done with the switch on the product and zero calibration.)



Compact size

These are 46% of the volume, compared to existing EP sensor. The total space has been reduced due to the ability to directly connect to an external control device without the use of an amplifier, etc.

Use computer support software to set the electrostatic potential sensor

You can set the electrostatic potential sensor by using the support software on a computer. Settings are via RS485 communication. You can also acquire logs.

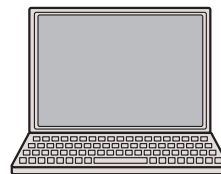

*Download the support software from Koganei's homepage (free of charge).

Enables confirmation of ionizer performance with ion balance measurement function

Easy checking of simple ion balance by mounting a monitor plate^{note}.

Note: Monitor plate is optional.

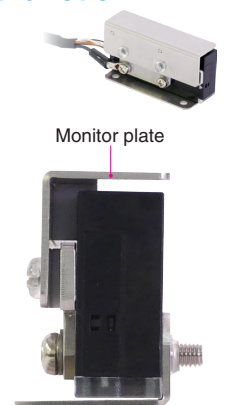
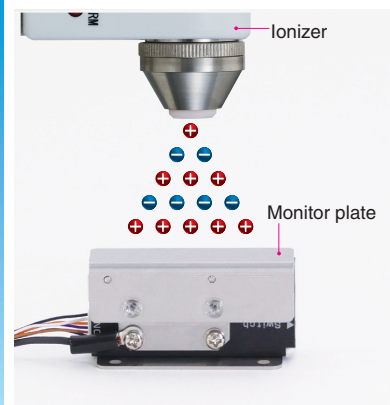

* For the distance between the ionizer and monitor plate, see the recommended minimum position distances set by each ionizer manufacturer.

Component bracket available

With a separately sold component bracket, various mounting directions become possible.



Measurement distance and measurement range/measured voltage range

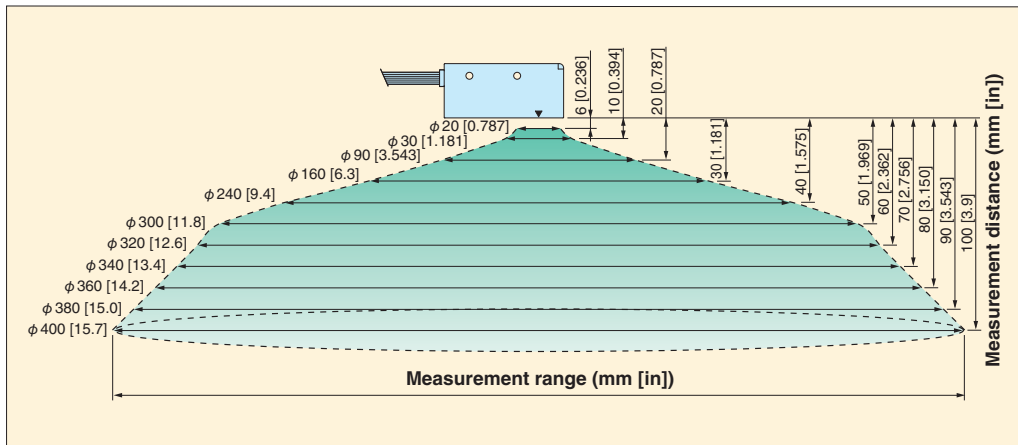

Measurement distance and measurement range

Measured distance	Measurement range	Measured distance	Measurement range
6 [0.236]	φ20 [0.787]	50 [1.969]	φ300 [11.8]
10 [0.394]	φ30 [1.181]	60 [2.362]	φ320 [12.6]
15 [0.591]	φ60 [2.362]	70 [2.756]	φ340 [13.4]
20 [0.787]	φ90 [3.543]	80 [3.150]	φ360 [14.2]
30 [1.181]	φ160 [6.3]	90 [3.543]	φ380 [15.0]
40 [1.575]	φ240 [9.4]	100 [3.9]	φ400 [15.7]

Note: Anything that disturbs an electric field (relays, solenoids, metal objects, etc.) between the vicinity of the electrostatic potential sensor and the sensor for the object being measured can affect measured values.

Measurement distance and measured voltage range

Measurement distance (mm [in])	Standard mode		High voltage mode	
	Range [V]	Resolution [V]	Range [kV]	Resolution [V]
6 to 15 [0.236 to 0.591]	±1000	1	±10.00	10
16 to 50 [0.630 to 1.969]	±2000	1	±20.00	10
51 to 100 [2.008 to 3.9]	±2000	2	±20.00	20

* The ion balance mode has a range of ± 1000 V and resolution of 1 V.

* Resolution capacity is for measuring an object that exceeds the measurement range. If the object being measured is smaller than the measurement range, the workpiece size can be set to compensate the amount of static charge that is output, but the resolution capacity will degrade.

Likewise, when the amount of static charge is within a ± 50 V range (a ± 500 V range in high voltage mode), the resolution capacity degrades more than that noted in the above table.

Application Examples

- Measure the potential before and after elimination

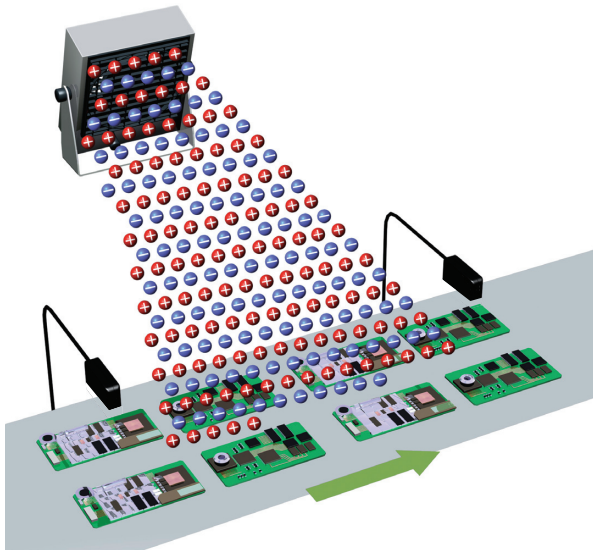

- Mount the monitor plate and measure the ion balance of the ionizer

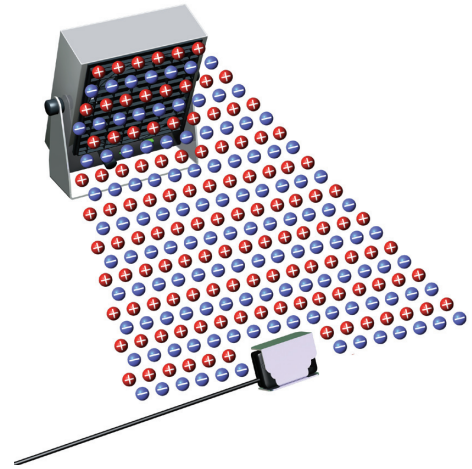

- Electric potential measurement of wafers, etc.

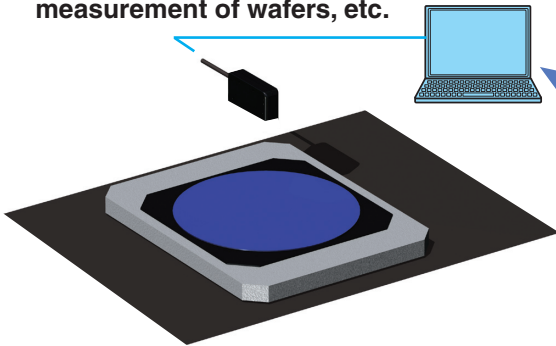

Settings, displays, and management can be done from the support software.

Free of charge

Support software's log data

Convert log data to a graph (image)

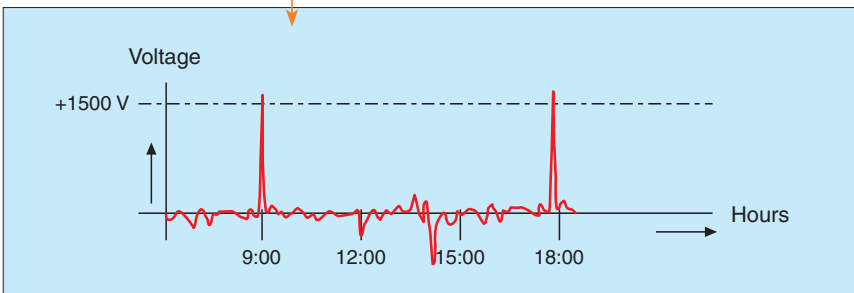

This is an example for which the spreadsheet software's graph display function was used (image).

Download the support software from our homepage to use it.

* Compatible OS: **Windows XP SP3** and higher
 * **NET FRAMEWORK 4.0** or higher must be installed

You can quickly determine the cause when abnormalities occur!

Connection Patterns

① Using the analog output type

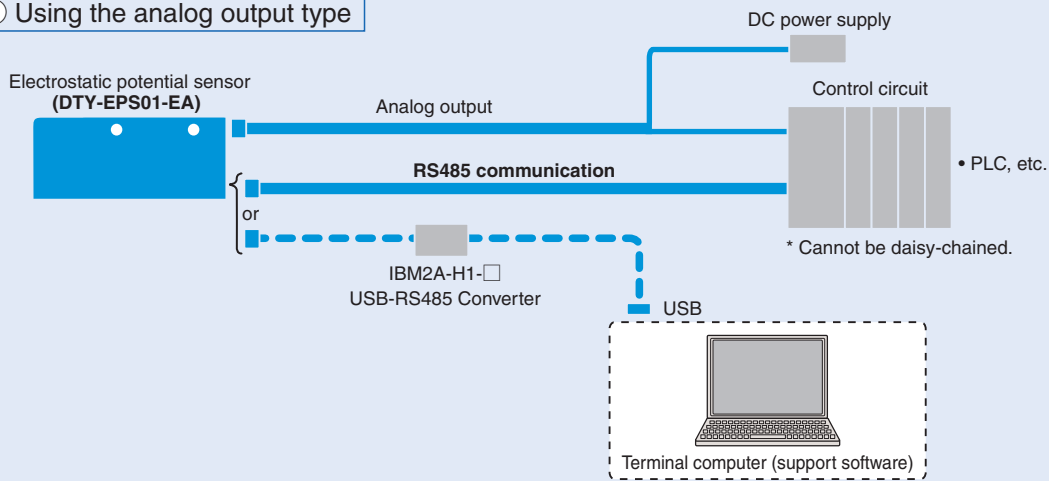

② Using the switch output type

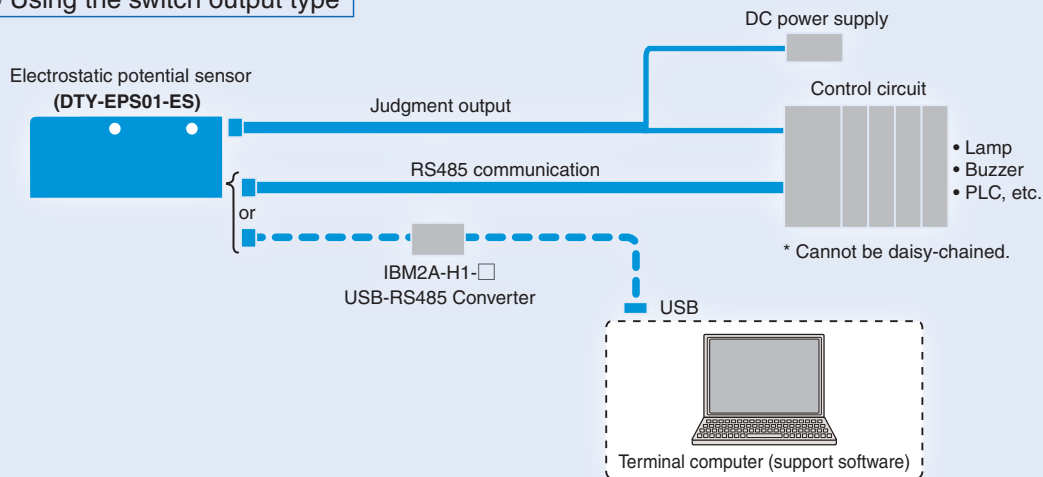

③ Status monitoring application

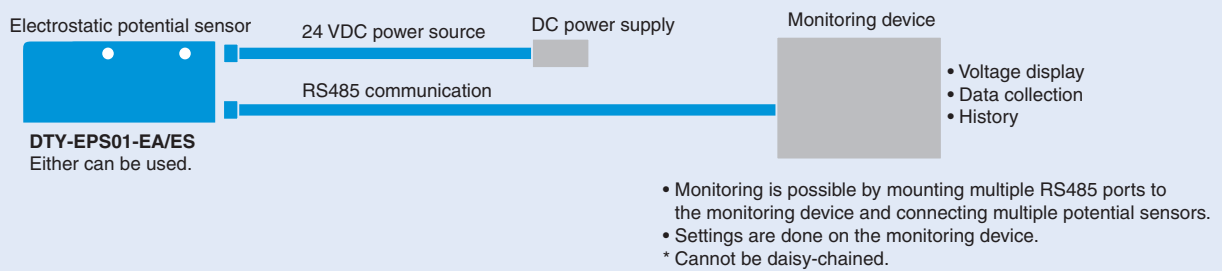

Handling Instructions and Precautions



General precautions

CAUTION

1. The product is an industrial sensor; it is not a meter for measuring absolute electric potential. Its measurement accuracy is not 100% guaranteed.
2. For the DC power source, use a power source that has 24 VDC output voltage with double or reinforced insulation between the input and output. For the DC power source, use a power source below 24 V/4 A (100 W).

Wiring

1. When using a power supply with a commercially available switching regulator, be sure to connect a frame ground (F.G.).
2. When using devices that generate noise (switching regulator, inverter motor, etc.) in the vicinity of the installed electrostatic potential sensor, be sure to connect a frame ground (F.G.) to the devices.
3. After completing wiring work, check to make sure that all connections are correct.
4. Wiring for the electrostatic potential sensor should be within 30 m [98.425 ft] as stipulated by EN standards.

Other

1. Check fluctuations in the power source to confirm they do not exceed the ratings before turning on the power.
2. Avoid use during the transitional state (0.5 second) when the power is turned on.
3. Never use a needle or any other sharp pointed object to perform key operations.

Names and functions for the electrostatic potential sensor

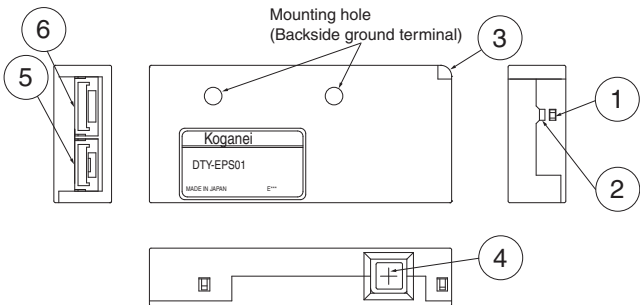

Name	Description
① Measurement mode switch/measurement modes	Press and hold for 5 seconds: switches Zero calibration switch Under 5 seconds: starts zero calibration
② LED for measurement modes (blue)	In standard mode: unlit, in high voltage mode: lit, in ion balance mode: flashing
③ Indicator LED (green/red/blue)	reen LED lit: normal Measurement value over range: red LED lit Error detected: green LED goes out, red LED lights Judgment output is on: yellow LED lit *switch output type only
④ Static charge potential measuring element	Use facing the static charge potential measuring element toward the object to be measured.
⑤ Communication connector (COM2)	Connect the communication cable or the cable for the USB-RS485 converter
⑥ Power and signal connectors (COM1)	Connect the power and signal cable

Measurement

If consistent measurements are needed, we recommend waiting 10 minutes or more after turning on the power before using the sensor. The measured values may fluctuate slightly immediately after the power is turned on because the circuits have not stabilized. After turning on the power, measurement starts after the green LED has flashed for 2 seconds. Furthermore, judgment output is after the data output cycle has elapsed.

Zero calibration

Zero calibration sets the measured value as 0 V for the standard potential, and 0 V potential is read.
Z.C. signal: Turn on the zero calibration (close the contact). The yellow LED flashes for 2 seconds. After that, it goes out. Zero calibration can also be done with the switch on the potential sensor.
Press the measurement range switch/zero calibration switch on the side of the potential sensor.
The yellow LED flashes for 2 seconds. After that, it goes out.

Note: Do not push and hold for 5 seconds during zero calibration. If you press and hold it for more than 5 seconds, the measurement range will change. If it happens to change, press and hold the switch again for more than 5 seconds to change it back to the measurement mode.

Installation

1. Install the surface of the measuring part of the potential sensor so it is parallel to the surface to be measured on the object from which to remove the static charge.
2. If the installation location is subject to vibrations, it may affect the accuracy of the measurements. Install the sensor where there are no vibrations.
3. Use high-strength frames and other hardware for installing the product. If it is not strong, it may affect the accuracy of the measurements. Also, be sure to use screws to mount the product.
4. Be careful to not overtighten the mounting screws when mounting the potential sensor on the mounting bracket. Doing so could damage or break the product. (Recommended tightening torque for the mounting screws: 0.3 N·m [0.221 in·lbf])
5. The measured electric potential is related to the proximity of and distance to the objects from which to remove the charge. Install it so the distance is as accurate as possible.
6. Always ground the potential sensor, because it has an effect on the accuracy of measurements. The cable or the mounting holes in the potential sensor are the ground.
7. If it is not possible to avoid some voltage in the installation location, use appropriate insulation. If you do not use insulation, it will affect not only the measured values, but it may also create a ground or short circuit.
8. The potential sensor measures the strength of the electric field, and then calculates the voltage value. Therefore, note that anything near the sensor or between the sensor and the object from which a charge is being removed that disrupts the magnetic field (such as relays, solenoids, metal scraps, etc.) affects the measured values.
9. The measurements will not be consistent if the sensor is installed near an ionizer. Install the sensor so it is as far away as possible. Installing the potential sensor on a straight line through the object from which to remove the charge and the ionizer may have an effect on the accuracy of measurements.

● Installing brackets

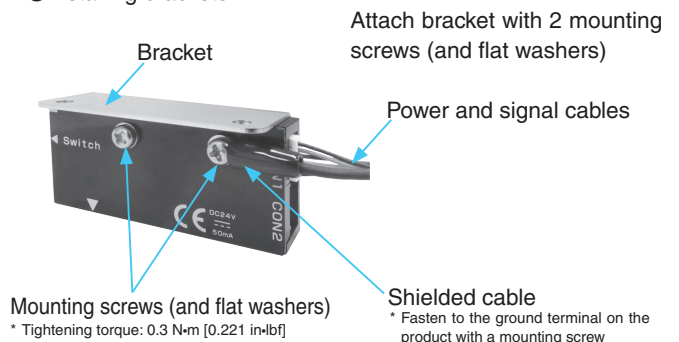

Electrostatic Potential Sensor Specifications

Item	Model	Analog output type	Switch output type
		DTY-EPS01-EA	DTY-EPS01-ES
Voltage	[V]	24 VDC \pm 10%	
Current	[mA]	max 50	
Indicator light		Power LED (green): lit when power is on	
		Indicator LED (blue) for settings mode: not lit in standard mode; lit in high voltage mode; flashes in ion balance mode	
		Indicator LED (red) for abnormalities: lit when over range or sensor abnormality occurs	
		—	Indicator LED (yellow) for switch: lit during switch output
Analog output ^{Note 1}		1 to 5 V analog output 1 (Zero-point 3 V, full scale 4 V) (Output impedance approximately 100 Ω)	—
Output		Alarm output 1 (NPN open collector output) (24 VDC \pm 10%/max 50 mA) (Internal voltage drop max 0.3 V @ 5 mA/max 1.0 V @ 50 mA)	Judgment output 2 Alarm output 1 (NPN open collector output) (24 VDC \pm 10%/max 50 mA) (Internal voltage drop max 0.3 V @ 5 mA/max 1.0 V @ 50 mA)
Input		Zero calibration input 1 (Shared 24 VDC output voltage power source, input current 4.8 mA @ 24 VDC, input impedance 4.7 k Ω) * Zero calibration is within \pm 200 V	
Measurement distance	(mm [in])	6 to 100 [0.236 to 3.9]	
Measurement range	(mm [in])	ϕ 20 to ϕ 400 [0.787 to 15.7]	
Accuracy		\pm 5% F.S.	
Data output cycle	[ms]	10 Smoothing: 50, 100, 200, 500, 1000 (depending on the setting)	
Settings mode		Ion balance mode/Standard mode/High voltage mode	
Button settings		1 pc. (Measurement mode switch/Zero calibration)	
Communication I/F		Set via RS485 communication	
Temperature characteristics		+0.5% F.S./ $^{\circ}$ C or under (0 to 40 $^{\circ}$ C [0 to 104 $^{\circ}$ F], standard of 25 $^{\circ}$ C [77 $^{\circ}$ F])	
Usage environment		0 to 40 $^{\circ}$ C [0 to 104 $^{\circ}$ F]/less than 65% (non-condensation, non-freezing)	
Storage environment		-20 to 60 $^{\circ}$ C [-68 to 140 $^{\circ}$ F] (non-condensation, non-freezing)	
Case material		Conductive ABS resin	
External dimensions	mm [in]	55 (W) \times 25 (H) \times 10.5 (D) [2.165 (W) \times 0.984 (H) \times 0.413 (D)]	
Weight	g [oz]	13 [0.459] (cable included)	
Accessories		1 L shaped mounting bracket with mounting screws, 2 flat washers	
		Attached according to order code	
		1 power and signal cable (blank: none, -3L: 3 m cable, -10L: 10 m cable) 1 communication cable (blank: none, -1RLN: 1 m cable, -3RLN: 3 m cable, -10RLN: 10 m cable)	

Note 1: If the electric charge goes over in the positive direction of the measured range, 5.2 V is output. If it goes over in the negative direction, 0.7 V is output. Do not short circuit the analog output.

Remark: If no measurement conditions are specified, the temperature range is 25 $^{\circ}$ C [77 $^{\circ}$ F].

Output Circuit for the Electrostatic Potential Sensor and Cable Signal Table

● Analog output type

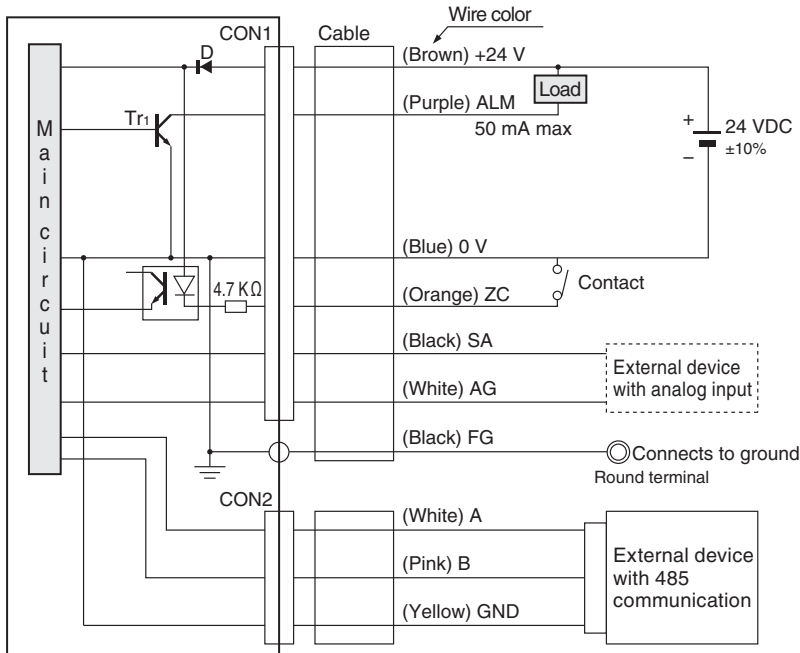

Cable signal table (analog output type)

Number	Name	Input/output	Cable color	Description
1	0 V Note	—	Blue	Power supply GND
2	+24 V	—	Brown	Power supply +24
3	Z.C	Input	Orange	Zero calibration input
4	ALM	Output	Purple	Sensor abnormality
5	AG Note	—	White	Analog GND
6	SA	Output	Black	Analog output (1 to 5 V)

Note: The 0 V (power ground), AG (analog ground), and ground terminal are internally connected.

● Switch output type

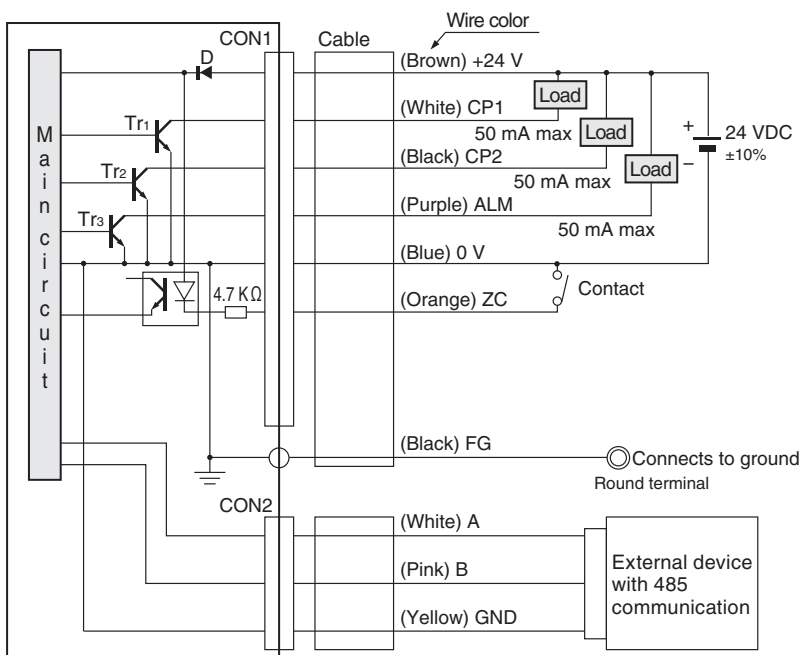

Cable signal table (switch output type)

Number	Name	Input/output	Cable color	Description
1	0 V	—	Blue	Power source GND
2	+24 V	—	Brown	Power supply +24
3	Z.C	Input	Orange	Zero calibration input
4	ALM	Output	Purple	Sensor abnormality
5	CP1	Output	White	Judgment output 1
6	CP2	Output	Black	Judgment output 2

Note: The 0 V (power ground) and ground terminal are connected inside.

Order Codes

Electrostatic Potential Sensor

DTY - EPS01 - - -

Electrostatic potential sensor

Communication cable

Blank : no communication cable
 1RLN : Cable length: 1 m [3.281 ft]
 3RLN : Cable length: 3 m [9.843 ft]
 10RLN : Cable length: 10 m [32.808 ft]

Power and signal cables

Blank : no cable
 3L : Cable length: 3 m [9.843 ft]
 10L : Cable length: 10 m [32.808 ft]

Output type

EA: Analog output type
 ES: Switch output type



Note: L shaped mounting bracket (mounting screws and flat washers, 2 each) are included for mounting to the electrostatic potential sensor.

Additional parts (to be ordered separately)

Component bracket

●DTY-EPP-BR2



Monitor plate

●DTY-EPP-MP01

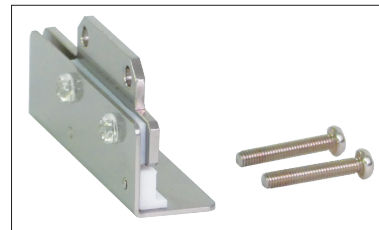

Power and signal cables

●DTY-EPP-CD-

Cable length
 3L: 3 m [9.843 ft]
 10L: 10 m [32.808 ft]

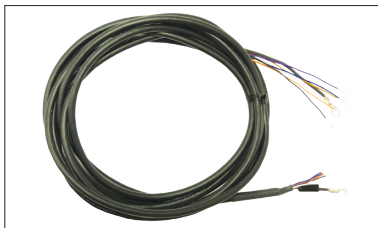

Communication cable

●DTY-EPP-CG-

Cable length
 1RLN: 1 m [3.281 ft]
 3RLN: 3 m [9.843 ft]
 10RLN: 10 m [32.808 ft]

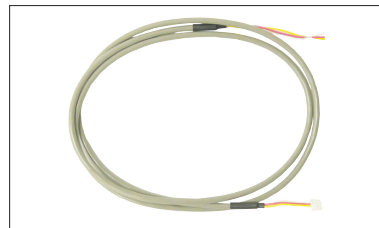

USB-RS485 Converter

●IBM2A-H1-

Cable included
 Blank : USB (mini-B) ⇔ USB (A), male
 N : Cable not included

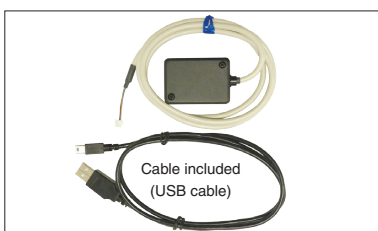

Dimensions (mm [in])

Electrostatic potential sensor

●DTY-EPS01-□

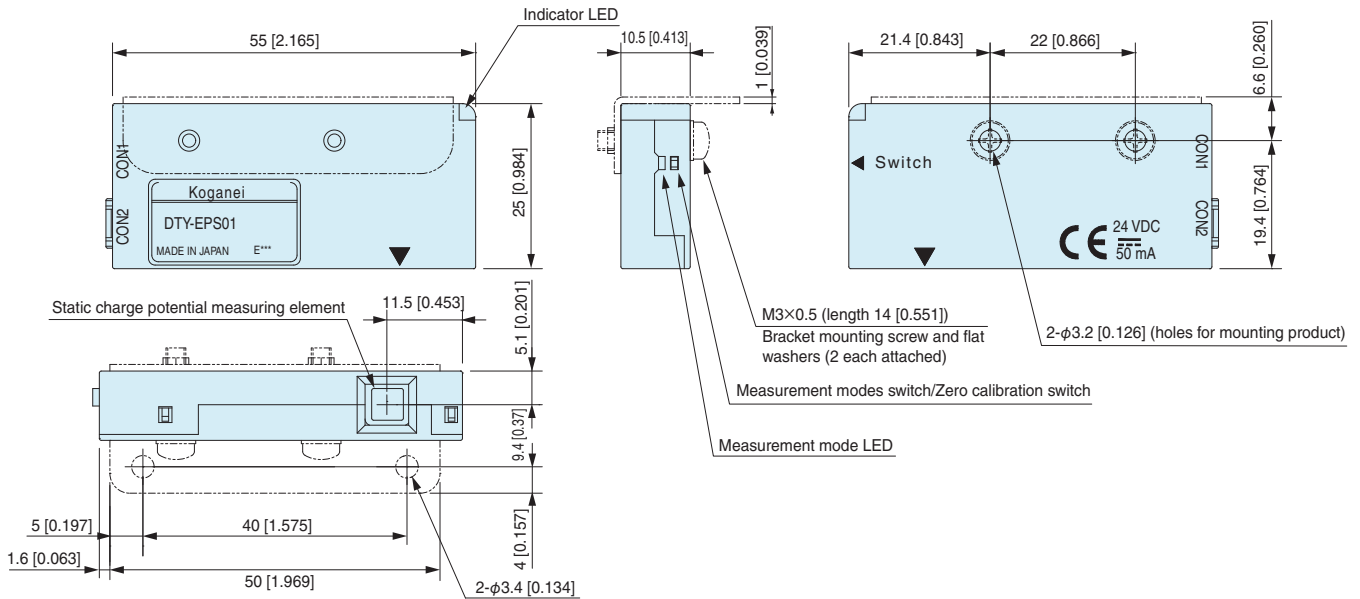

Component bracket

●DTY-EPP-BR2

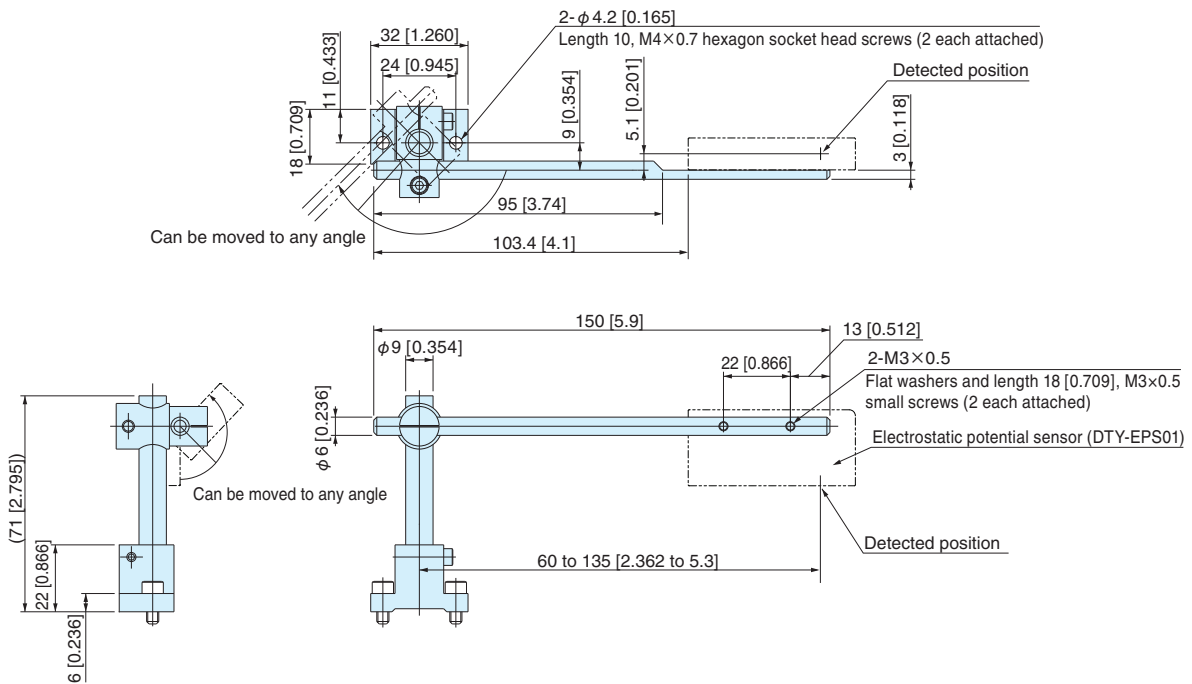

Monitor plate

●DTY-EPP-MP01

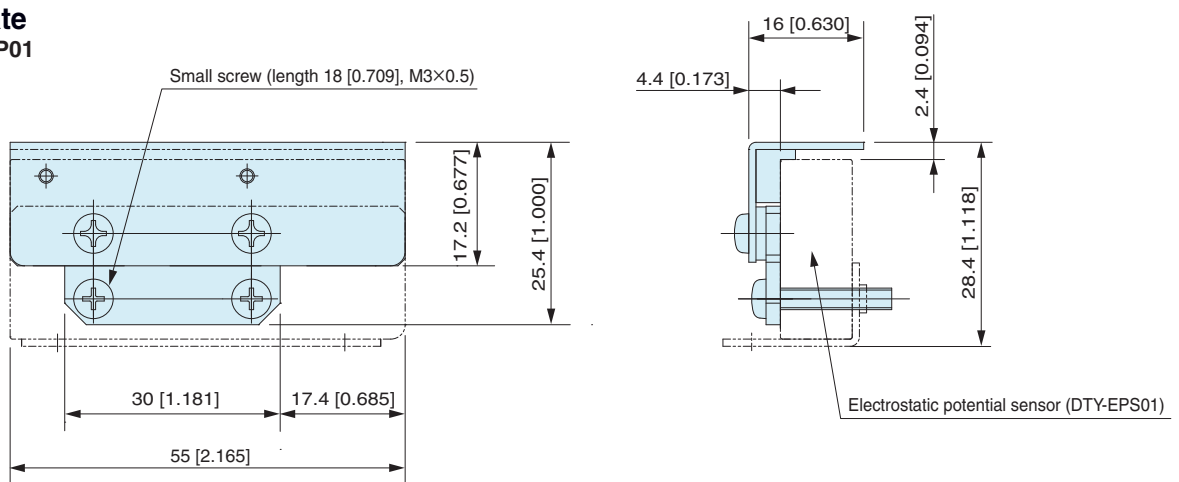

Dimensions (mm [in])

Power source and signal cables for the electrostatic potential sensor

●DTY-EPP-CD-□

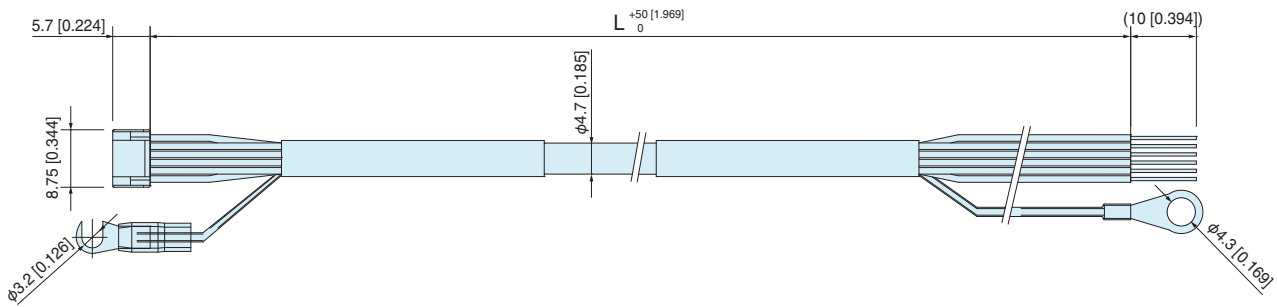

Models	L
DTY-EPP-CD-3L	3000 [118]
DTY-EPP-CD-10L	10000 [394]

Communication cables for the electrostatic potential sensor

●DTY-EPP-CG-□

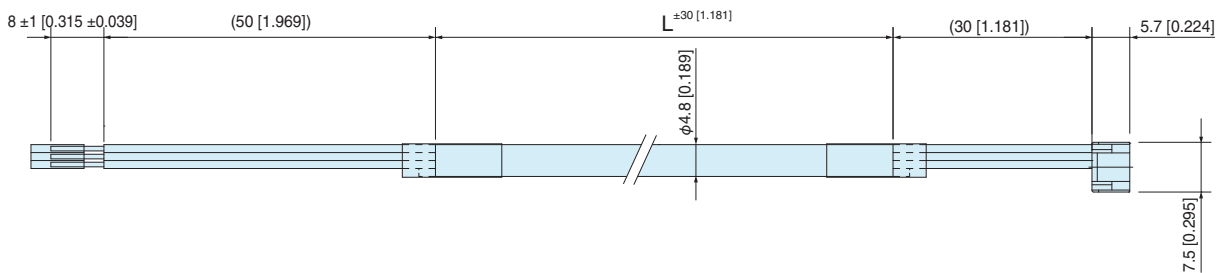

Models	L
DTY-EPP-CG-1RLN	1000 [39]
DTY-EPP-CG-3RLN	3000 [118]
DTY-EPP-CG-10RLN	10000 [394]

*Read the safety precautions and common precautions on the ionizer general catalog homepage before using this produce.



KOGANEI CORPORATION

OVERSEAS DEPARTMENT
3-11-28, Midori-cho, Koganei City, Tokyo 184-8533, Japan
Tel: 81-42-383-7271 Fax: 81-42-383-7276

KOGANEI ASIA PTE. LTD.
69 Ubi Road 1, #05-18 Oxley Bizhub,
Singapore 408731
Tel: 65-6293-4512 Fax: 65-6293-4513

KOGANEI (THAILAND) CO., LTD.
3300/90, Tower B, Elephant Tower, 16th Fl., Phaholyothin Road,
Chomphon, Chatuchak, Bangkok 10900, Thailand
Tel: 66-2-937-4250 Fax: 66-2-937-4254

Koganei International America, Inc.
39300 Civic Center Drive, Suite 280
Fremont, California 94538
Tel: 510-744-1626 Fax: 510-744-1676

URL <http://www.koganei.co.jp>

● Note that improvements may result in unannounced changes to the specifications and appearances described here.

August 17, 2016 First version KG © Koganei Corp. Printed in Japan