



CAD drawing data catalog is available.



# KOGANEI

## ACCESSORIES GENERAL CATALOG

AIR TREATMENT, AUXILIARY, VACUUM,  
AND FLUORORESIN PRODUCTS

## VACUUM PADS CONTENTS

Specifications	729
Order Codes	730
Theoretical Lifting Force, Rubber Pad Materials and Applications	731
Mass	732
Dimensions of Rubber Pads	733
Dimensions of KPHF	735
Dimensions of KPVF	737
Dimensions of KPPF	738
Dimensions of KPLF	739
Dimensions of KPHS	740
Dimensions of KPVS	742
Dimensions of KPPS	743
Dimensions of KPLS	744
Dimensions of Rubber Pad Mounting Portion	745
Handling Instructions and Precautions	747



### Caution

Before use, be sure to read the "Safety Precautions" on p. 49.

# VACUUM PADS

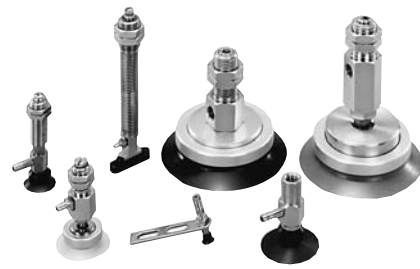

## Specifications

### ● Standard type, horizontal piping

Item	Model	Horizontal piping, fixed <sup>Note 3</sup>							Horizontal piping, with built-in spring <sup>Note 3</sup>							
		KPHF							KPHS							
Pad diameter <sup>Note 1</sup>	mm	2.5, 3.5	6, 8	10	25	35	60, 80	120	2.5, 3.5	6, 8	10	25, 30	60, 80	120		
		2×4		15		40		95	150		2×4		15	35	95	150
		3.5×7		20		50		100	200		3.5×7		20	40, 50	100	200
Applicable tube size or port thread	mm	4×2.5	6×4			Rc1/8		4×2.5	6×4			Rc1/8				
Spring stroke	mm [in.]	—							3 [0.12]	5 [0.20]	6 [0.24]	7 [0.28]	10 [0.39]	20 [0.79]		
Spring return force (at 1/2 stroke) N [lbf.]		—							1.8 [0.40]	2.6 [0.58]	1.0 [0.22]	3.5 [0.79]	9.8 [2.20]	10.8 [2.43]		
Materials	Major mounting body section	Body	Brass (nickel plated)				Steel (nickel plated)		Brass (nickel plated)			Steel (nickel plated)				
		Case body	—				Aluminum alloy (anodized)	—	—			Aluminum alloy (anodized)	—			
		Cover	—				Synthetic rubber: NBR		—			Synthetic rubber: NBR				
		O-ring	—				Synthetic rubber: NBR		—			Synthetic rubber: NBR				
		Guide	—				—		Brass (nickel plated)			Steel (nickel plated)				
		Spring	—				—		Stainless steel			Piano wire (zinc plated)				
Rubber pad (color)		Synthetic rubber: NBR (black), urethane (green), silicone (white), fluorine (black with white mark)														

### ● Standard type, vertical piping

Item	Model	Vertical piping, fixed				Vertical piping, with built-in spring			
		KPVF				KPVS			
Pad diameter <sup>Note 1</sup>	mm	2.5, 3.5	6, 8	10, 15, 20	25, 30, 35	2.5, 3.5	6, 8	10, 15, 20	25, 30, 35
		2×4, 3.5×7		40, 50	40, 50	2×4, 3.5×7		40, 50	
Applicable tube size <sup>Note 2</sup>	mm	4×2.5	6×4			4×2.5	6×4		
Spring stroke	mm [in.]	—				3 [0.12]	3 [0.12]	5 [0.20]	9 [0.35]
Spring return force (at 1/2 stroke) N [lbf.]		—				2.5 [0.56]	2.4 [0.54]	1.0 [0.22]	4.9 [1.10]
Materials	Body	Brass (nickel plated)							
	Rubber pad (color)	Synthetic rubber: NBR (black), urethane (green), silicone (white), fluorine (black with white mark)							

- Notes : 1. For the pad sizes inside the same pad diameter box, their mounting bodies are all the same. (Some of the rubber pad mounting screws are not identical).  
 2. For the tubes, select the urethane tube.  
 3. To change to the vertical piping of  $\phi 60 \sim \phi 200$ , replace the R1/8 piping plug.

### ● Ball joint type

Item	Model	Horizontal piping, fixed <sup>Note 2</sup>				Horizontal piping, with built-in spring <sup>Note 2</sup>				
		KPPF				KPPS				
Pad diameter <sup>Note 1</sup>	mm	10	20	40	60	10	20	40	60	
		15	25	50	80	15	25	50	80	
			30	50	80		35	50	80	
Applicable tube size or port thread	mm	6×4 (M5)		Rc 1/8	6×4 (M5)		Rc 1/8			
Spring stroke	mm [in.]	—				5 [0.20]	10 [0.39]	10 [0.39]		
		—				10 [0.39]	20 [0.79]	30 [1.18]		
		—				20 [0.79]	30 [1.18]	50 [1.97]		
		—				30 [1.18]	50 [1.97]	70 [2.76]		
Spring return force (at 1/2 stroke)	N [lbf.]	—				4.0 [0.90]		14.1 [3.17]		
Materials	Major mounting body portion	Body	Brass (nickel plated)						Steel (nickel plated)	
		Main shaft	Steel							
		Case body	Brass (nickel plated)	Steel (nickel plated)	Brass (nickel plated)		Steel (nickel plated)			
		Cover	Aluminum alloy (anodized)							
		O-ring	Synthetic rubber: NBR							
		Spring	—				Stainless steel			
Rubber pad (color)		Synthetic rubber: NBR (black), urethane (green), silicone (white), fluorine (black with white mark)								

- Notes: 1. For the pad sizes inside the same pad diameter box, their mounting bodies are all the same.  
 2. To change to the vertical piping, replace the horizontal piping use fitting and plug. (For pad sizes 60 and 80, replace only plug.)

### ● Non-rotating type

Item	Model	Horizontal piping, fixed <sup>Note 2</sup>		Horizontal piping, with built-in spring <sup>Note 2</sup>		
		KPLF		KPLS		
Pad shape		Round	Oval	Round	Oval	
Pad diameter <sup>Note 1</sup>	mm	6	2×4	4×20	6	4×20
			5×20	5×20		5×20
			6×20	6×20		6×20
			8×20	8×20		8×20
			8×20	8×20		8×20
Applicable tube size or port thread	mm	6	3.5×7	4×2.5 (M3)	8	3.5×7
			4×10	4×30		4×10
			5×10	5×30		5×10
			6×10	6×30		6×10
Spring stroke	mm [in.]	10	6×30	6×30	10	6×30
			8×30	8×30		8×30
			5 [0.20]	5 [0.20]		5 [0.20]
			10 [0.39]	10 [0.39]		10 [0.39]
Spring return force (at 1/2 stroke)	N [lbf.]	—	20 [0.79]	20 [0.79]	—	20 [0.79]
			30 [1.18]	30 [1.18]		30 [1.18]
			2.9 [0.65]	2.9 [0.65]		2.9 [0.65]
			—	—		—
Materials	Major mounting body portion	Rod	Brass (nickel plated)		Brass (chrome plated)	
		Guide	—		Oil-impregnated steel alloy	
		Spring	—		Stainless steel	
		Rubber pad (color)	Synthetic rubber: NBR (black), urethane (green), silicone (white), fluorine (black with white mark)			

- Notes: 1. For the pad sizes inside the same pad diameter box, their mounting bodies are all the same.  
 2. To change to the vertical piping, replace the horizontal piping use fitting and plug.

# Order Codes

## Conductive vacuum pad

### Vacuum pad model (with mounting body)

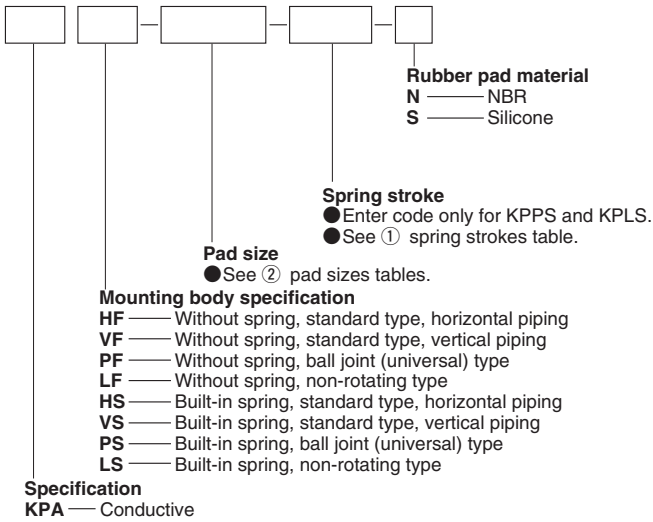

### Rubber pad model (without mounting body)

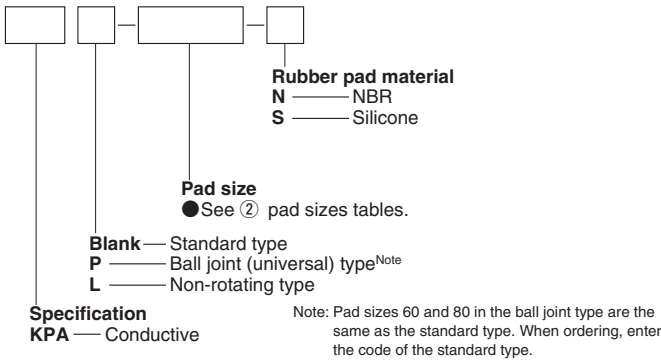

## ① Spring strokes

### (1) KPPS spring strokes

Pad diameter	Spring strokes mm					
	5	10	20	30	50	70
10, 15	○	○	○	○	—	—
20, 25, 30, 35	—	○	○	○	○	—
40, 50	—	○	○	○	○	—
60, 80	—	○	—	○	○	○

### (2) KPLS spring strokes

5mm, 10mm, 20mm, 30mm available in each pad size

## ② Pad sizes

### (1) Standard type

Model	Pad diameter
2	φ 2.5
3.5	φ 3.5
2×4	2×4 (oval)
3.5×7	3.5×7 (oval)
6	φ 6
8	φ 8
10	φ 10
15	φ 15
20	φ 20
25	φ 25
30	φ 30
35	φ 35
40	φ 40
50	φ 50
60	φ 60
80	φ 80
95	φ 95
100	φ 100
120	φ 120
150	φ 150
200	φ 200

### (2) Ball joint type

Model	Pad diameter
10	φ 10
15	φ 15
20	φ 20
25	φ 25
30	φ 30
35	φ 35
40	φ 40
50	φ 50
60	φ 60
80	φ 80

### (3) Non-rotating type

Model	Pad diameter
6	φ 6
8	φ 8
10	φ 10
2×4	2×4 (oval)
3.5×7	3.5×7 (oval)
4×10	4×10 (oval)
5×10	5×10 (oval)
6×10	6×10 (oval)
4×20	4×20 (oval)
5×20	5×20 (oval)
6×20	6×20 (oval)
8×20	8×20 (oval)
4×30	4×30 (oval)
5×30	5×30 (oval)
6×30	6×30 (oval)
8×30	8×30 (oval)

## ● Conductive vacuum pad (NBR, silicone)

The vacuum pad rubber material is conductive rubber, for passing static electricity and preventing electrification.

## Volume resistivity, and identification mark

Rubber pad material	Volume resistivity <sup>Note</sup>	ID mark
Conductive NBR	10 <sup>2</sup> ~10 <sup>5</sup> Ωcm	Blue point mark
Conductive silicone	1~10 <sup>2</sup> Ωcm	Yellow point mark

Note: Specified values for the materials.

# Theoretical Lifting Force

## ● Round pad

Vacuum kPa [in.Hg]	Pad diameter mm [in.]	φ 2.5	φ 3.5	φ 6	φ 8	φ 10	φ 15	φ 20	φ 25	φ 30	φ 35	φ 40	φ 50	φ 60	φ 80	φ 95	φ 100	φ 120	φ 150	φ 200
		[0.098]	[0.138]	[0.24]	[0.31]	[0.39]	[0.59]	[0.79]	[0.98]	[1.18]	[1.38]	[1.57]	[1.97]	[2.36]	[3.15]	[3.74]	[3.94]	[4.72]	[5.91]	[7.87]
	Pad area Acm <sup>2</sup> [in. <sup>2</sup> ]	0.049	0.096	0.283	0.502	0.785	1.766	3.14	4.906	7.065	9.616	12.56	19.63	28.26	50.24	70.85	78.5	113	176.6	314
		[0.0076]	[0.0149]	[0.0439]	[0.0778]	[0.1217]	[0.2738]	[0.4868]	[0.7606]	[1.095]	[1.4909]	[1.947]	[3.043]	[4.381]	[7.789]	[10.984]	[12.17]	[17.5]	[27.38]	[48.7]
-93.3 [-27.56]		0.457	0.896	2.64	4.68	7.32	16.48	29.3	45.8	65.9	89.7	117.2	183.1	264	469	661	732	1054	1648	2930
		[0.103]	[0.201]	[0.593]	[1.05]	[1.65]	[3.70]	[6.59]	[10.30]	[14.81]	[20.16]	[26.35]	[41.16]	[59.35]	[105]	[149]	[165]	[237]	[370]	[659]
-80.0 [-23.62]		0.392	0.768	2.26	4.02	6.28	14.13	25.1	39.2	56.5	76.9	100.5	157.0	226	402	567	628	904	1413	2512
		[0.088]	[0.173]	[0.508]	[0.90]	[1.41]	[3.18]	[5.64]	[8.81]	[12.70]	[17.29]	[22.59]	[35.29]	[50.80]	[90]	[127]	[141]	[203]	[318]	[565]
-66.7 [-19.69]		0.327	0.640	1.89	3.35	5.24	11.78	20.9	32.7	47.1	64.1	83.8	130.9	188	335	473	524	754	1178	2094
		[0.074]	[0.144]	[0.425]	[0.75]	[1.18]	[2.65]	[4.70]	[7.35]	[10.59]	[14.41]	[18.84]	[29.43]	[42.26]	[75]	[106]	[118]	[169]	[265]	[471]
-53.3 [-15.75]		0.261	0.512	1.51	2.68	4.18	9.41	16.7	26.1	37.7	51.3	66.9	104.6	151	268	378	418	602	941	1674
		[0.059]	[0.115]	[0.339]	[0.60]	[0.94]	[2.12]	[3.75]	[5.87]	[8.47]	[11.53]	[15.04]	[23.51]	[33.94]	[60]	[85]	[94]	[135]	[212]	[376]
-40.0 [-11.81]		0.196	0.384	1.13	2.01	3.14	7.06	12.6	19.6	28.3	38.5	50.2	78.5	113	201	283	314	452	706	1256
		[0.044]	[0.086]	[0.254]	[0.45]	[0.71]	[1.59]	[2.83]	[4.41]	[6.36]	[8.65]	[11.28]	[17.65]	[25.40]	[45]	[64]	[71]	[102]	[159]	[282]
-26.7 [-7.87]		0.131	0.256	0.76	1.34	2.10	4.72	8.4	13.1	18.9	25.7	33.5	52.4	75	134	189	210	302	472	838
		[0.029]	[0.058]	[0.171]	[0.30]	[0.47]	[1.06]	[1.89]	[2.94]	[4.25]	[5.78]	[7.53]	[11.78]	[16.86]	[30]	[42]	[47]	[68]	[106]	[188]
-13.3 [-3.94]		0.065	0.128	0.38	0.67	1.04	2.35	4.2	6.5	9.4	12.8	16.7	26.1	38	67	94	104	150	235	418
		[0.015]	[0.029]	[0.085]	[0.15]	[0.23]	[0.53]	[0.94]	[1.46]	[2.11]	[2.88]	[3.75]	[5.87]	[8.54]	[15]	[21]	[23]	[34]	[53]	[94]

Note: Figures in the above table are calculated values.

## ● Oval pad

Vacuum kPa [in.Hg]	Pad diameter mm [in.]	2×4	3.5×7	4×10	5×10	6×10	4×20	5×20	6×20	8×20	4×30	5×30	6×30	8×30
		[0.08×0.16]	[0.14×0.28]	[0.16×0.39]	[0.20×0.39]	[0.24×0.39]	[0.16×0.79]	[0.20×0.79]	[0.24×0.79]	[0.31×0.79]	[0.16×1.18]	[0.20×1.18]	[0.24×1.18]	[0.31×1.18]
	Pad area Acm <sup>2</sup> [in. <sup>2</sup> ]	0.0714	0.2187	0.3657	0.4463	0.5227	0.7657	0.9963	1.1227	1.4627	1.1657	1.4463	1.7227	2.2627
		[0.01107]	[0.03391]	[0.05670]	[0.06919]	[0.08104]	[0.11871]	[0.15447]	[0.17406]	[0.22678]	[0.18073]	[0.22423]	[0.26709]	[0.35081]
-93.3 [-27.56]		0.666	2.040	3.412	4.16	4.88	7.14	9.30	10.47	13.65	10.88	13.49	16.07	21.11
		[0.150]	[0.459]	[0.767]	[0.94]	[1.10]	[1.61]	[2.09]	[2.35]	[3.07]	[2.45]	[3.03]	[3.61]	[4.75]
-80.0 [-23.62]		0.571	1.750	2.926	3.57	4.18	6.13	7.97	8.98	11.70	9.33	11.57	13.78	18.10
		[0.128]	[0.393]	[0.658]	[0.80]	[0.94]	[1.38]	[1.79]	[2.02]	[2.63]	[2.10]	[2.60]	[3.10]	[4.07]
-66.7 [-19.69]		0.476	1.459	2.439	2.98	3.49	5.11	6.65	7.49	9.76	7.78	9.65	11.49	15.09
		[0.107]	[0.328]	[0.548]	[0.67]	[0.78]	[1.15]	[1.49]	[1.68]	[2.19]	[1.75]	[2.17]	[2.58]	[3.39]
-53.3 [-15.75]		0.381	1.166	1.949	2.38	2.79	4.08	5.31	5.98	7.80	6.21	7.71	9.18	12.06
		[0.086]	[0.262]	[0.438]	[0.54]	[0.63]	[0.92]	[1.19]	[1.34]	[1.75]	[1.40]	[1.73]	[2.06]	[2.71]
-40.0 [-11.81]		0.286	0.875	1.463	1.79	2.09	3.06	3.99	4.49	5.85	4.66	5.79	6.89	9.05
		[0.064]	[0.197]	[0.329]	[0.40]	[0.47]	[0.69]	[0.90]	[1.01]	[1.32]	[1.05]	[1.30]	[1.55]	[2.03]
-26.7 [-7.87]		0.191	0.584	0.976	1.19	1.40	2.04	2.66	3.00	3.91	3.11	3.86	4.60	6.04
		[0.043]	[0.131]	[0.219]	[0.27]	[0.31]	[0.46]	[0.60]	[0.67]	[0.88]	[0.70]	[0.87]	[1.03]	[1.36]
-13.3 [-3.94]		0.095	0.291	0.486	0.59	0.70	1.02	1.33	1.49	1.95	1.55	1.92	2.29	3.01
		[0.021]	[0.065]	[0.109]	[0.13]	[0.16]	[0.23]	[0.30]	[0.33]	[0.44]	[0.35]	[0.43]	[0.51]	[0.68]

Note: Figures in the above table are calculated values.

# Rubber Pad Materials and Applications

## ● Rubber pad materials and characteristics

Item	Hardness Hs	Operating temperature range °C [°F]	Tensile strength (N/cm <sup>2</sup> ) [psi.]	Elonga- tion (%)	Oil resistance (gasoline)	Oil resistance (benzol)	Weather resistance	Ozone resistance	Alkali resistance	Acid resistance	Water resistance	Wear resistance	Electrical insulation	Tear resistance
NBR (N)	70±5	0~100 [32~212]	1970 [2860]	740	◎	△	○	×	○	○	◎	◎	○	○
Silicone (S)	50±5	-30~200 [-22~392]	830 [1200]	300	△	△	◎	◎	◎	△	○	×	◎	×

Remark: ◎Optimum ○Suitable under certain conditions △Not recommended ×Cannot be used

Note: This table shows the general characteristics of rubber. Take full consideration of various operating conditions.

# Mass

## ● Standard type

		g [oz.]																				
Model	Pad diameter mm [in.]	2.5	3.5	2×4	3.5×7	6	8	10	15	20	25	30	35	40	50	60	80	95	100	120	150	200
		[0.10]	[0.14]	[0.08×0.16]	[0.14×0.28]	[0.24]	[0.31]	[0.39]	[0.59]	[0.79]	[0.98]	[1.18]	[1.38]	[1.57]	[1.97]	[2.36]	[3.15]	[3.74]	[3.94]	[4.72]	[5.91]	[7.87]
Fixed type	KPHF	3	3	3	3	11	11	14	15	16	31	31	36	37	47	216	224	234	235	573	619	1085
	KPVF	8	8	8	8	9	9	13	14	15	33	34	34	36	36	—	—	—	—	—	—	—
Spring type	KPHS	5	6	6	6	21	21	35	36	36	73	73	77	75	86	368	374	384	386	800	843	1311
	KPVS	9	9	9	9	10	10	24	25	26	50	50	51	53	63	—	—	—	—	—	—	—

## ● Ball joint type

		g [oz.]			
Model	Mass	Model	Mass		
Fixed type	KPPF-10	38 [1.34]	Spring type	KPPS-50-10	132 [4.66]
	KPPF-15	38 [1.34]		KPPS-50-20	142 [5.01]
	KPPF-20	52 [1.83]		KPPS-50-30	152 [5.36]
	KPPF-25	52 [1.83]		KPPS-50-50	172 [6.07]
	KPPF-30	55 [1.94]		KPPS-60-10	702 [24.76]
	KPPF-35	55 [1.94]		KPPS-60-30	779 [27.48]
	KPPF-40	101 [3.56]		KPPS-60-50	840 [29.63]
	KPPF-50	104 [3.67]		KPPS-60-70	902 [31.82]
	KPPF-60	436 [15.38]		KPPS-80-10	710 [25.04]
	KPPF-80	445 [15.70]		KPPS-80-30	787 [27.76]
Spring type	KPPS-10-5	61 [2.15]	KPPS-80-50	848 [29.91]	
	KPPS-10-10	66 [2.33]	KPPS-80-70	910 [32.10]	
	KPPS-10-20	76 [2.68]			
	KPPS-10-30	86 [3.03]			
	KPPS-15-5	61 [2.15]			
	KPPS-15-10	66 [2.33]			
	KPPS-15-20	76 [2.68]			
	KPPS-15-30	86 [3.03]			
	KPPS-20-10	80 [2.82]			
	KPPS-20-20	90 [3.17]			
	KPPS-20-30	100 [3.53]			
	KPPS-20-50	122 [4.30]			
	KPPS-25-10	80 [2.82]			
	KPPS-25-20	90 [3.17]			
	KPPS-25-30	100 [3.53]			
	KPPS-25-50	122 [4.30]			
	KPPS-30-10	80 [2.82]			
	KPPS-30-20	90 [3.17]			
	KPPS-30-30	100 [3.53]			
	KPPS-30-50	122 [4.30]			
	KPPS-35-10	80 [2.82]			
	KPPS-35-20	90 [3.17]			
	KPPS-35-30	100 [3.53]			
	KPPS-35-50	122 [4.30]			
	KPPS-40-10	128 [4.51]			
	KPPS-40-20	138 [4.87]			
	KPPS-40-30	148 [5.22]			
	KPPS-40-50	168 [5.93]			

## ● Non-rotating type

		g [oz.]			
Model	Mass	Model	Mass		
Fixed type	KPLF-6	13 [0.46]	Spring type	KPLS-5×10-5	39 [1.38]
	KPLF-8	13 [0.46]		KPLS-5×10-10	43 [1.52]
	KPLF-10	13 [0.46]		KPLS-5×10-20	52 [1.83]
	KPLF-2×4	13 [0.46]		KPLS-5×10-30	60 [2.12]
	KPLF-3.5×7	13 [0.46]		KPLS-6×10-5	39 [1.38]
	KPLF-4×10	13 [0.46]		KPLS-6×10-10	43 [1.52]
	KPLF-5×10	13 [0.46]		KPLS-6×10-20	52 [1.83]
	KPLF-6×10	13 [0.46]		KPLS-6×10-30	60 [2.12]
	KPLF-4×20	15 [0.53]		KPLS-4×20-5	42 [1.48]
	KPLF-5×20	15 [0.53]		KPLS-4×20-10	46 [1.62]
Spring type	KPLF-6×20	15 [0.53]	KPLS-4×20-20	55 [1.94]	
	KPLF-8×20	15 [0.53]	KPLS-4×20-30	63 [2.22]	
	KPLF-4×30	16 [0.56]	KPLS-5×20-5	42 [1.48]	
	KPLF-5×30	16 [0.56]	KPLS-5×20-10	46 [1.62]	
	KPLF-6×30	16 [0.56]	KPLS-5×20-20	55 [1.94]	
	KPLF-8×30	16 [0.56]	KPLS-5×20-30	63 [2.22]	
	KPLS-6-5	39 [1.38]	KPLS-6×20-5	42 [1.48]	
	KPLS-6-10	43 [1.52]	KPLS-6×20-10	46 [1.62]	
	KPLS-6-20	52 [1.83]	KPLS-6×20-20	55 [1.94]	
	KPLS-6-30	60 [2.12]	KPLS-6×20-30	63 [2.22]	
	KPLS-8-5	39 [1.38]	KPLS-8×20-5	42 [1.48]	
	KPLS-8-10	43 [1.52]	KPLS-8×20-10	46 [1.62]	
	KPLS-8-20	52 [1.83]	KPLS-8×20-20	55 [1.94]	
	KPLS-8-30	60 [2.12]	KPLS-8×20-30	63 [2.22]	
	KPLS-10-5	39 [1.38]	KPLS-4×30-5	42 [1.48]	
	KPLS-10-10	43 [1.52]	KPLS-4×30-10	46 [1.62]	
	KPLS-10-20	52 [1.83]	KPLS-4×30-20	55 [1.94]	
	KPLS-10-30	60 [2.12]	KPLS-4×30-30	63 [2.22]	
	KPLS-2×4-5	39 [1.38]	KPLS-5×30-5	42 [1.48]	
	KPLS-2×4-10	43 [1.52]	KPLS-5×30-10	46 [1.62]	
	KPLS-2×4-20	52 [1.83]	KPLS-5×30-20	55 [1.94]	
	KPLS-2×4-30	60 [2.12]	KPLS-5×30-30	63 [2.22]	
	KPLS-3.5×7-5	39 [1.38]	KPLS-6×30-5	42 [1.48]	
	KPLS-3.5×7-10	43 [1.52]	KPLS-6×30-10	46 [1.62]	
	KPLS-3.5×7-20	52 [1.83]	KPLS-6×30-20	55 [1.94]	
	KPLS-3.5×7-30	60 [2.12]	KPLS-6×30-30	63 [2.22]	
	KPLS-4×10-5	39 [1.38]	KPLS-8×30-5	42 [1.48]	
	KPLS-4×10-10	43 [1.52]	KPLS-8×30-10	46 [1.62]	
KPLS-4×10-20	52 [1.83]	KPLS-8×30-20	55 [1.94]		
KPLS-4×10-30	60 [2.12]	KPLS-8×30-30	63 [2.22]		

Note: The mass values shown above are the mass of a mounting body with rubber pad (NBR) attached.

# Dimensions of Rubber Pads (mm)

- KP-2
- KP-3.5

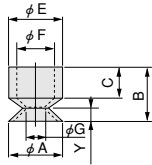

Model	Code	A	B	C	E	F	G	Y
KP-2		2.5	3.3	2	3.5	2.5	0.8	0.8
KP-3.5		3.9	3.5	2	3.5	2.5	1.6	1

- KP-6

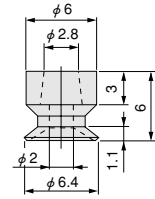

- KP-2×4
- KP-3.5×7

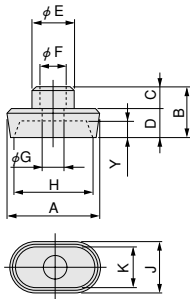

Model	Code	A	B	C	D	E	F
KP-2×4		5.5	4	2	2	3.5	2.4
KP-3.5×7		8	4.5	2	2.5	3.5	2.4

  

Model	Code	G	H	J	K	Y
KP-2×4		1.8	4	3.5	2	1.0
KP-3.5×7		2	7	4.5	3.5	1.5

- KP-8

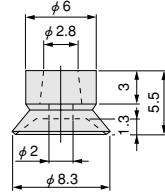

- KP-10
- KP-15
- KP-20
- KP-25

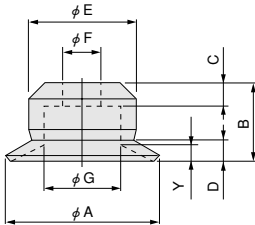

Model	Code	A	B	C	D	E	F	G	Y
KP-10		10	8	4	1.5	10	4.8	6	1.5
KP-15		15	8	3	2	11	4.8	8	1.2
KP-20		20	10	4	2.6	14	4.8	10.5	1.6
KP-25		25	14	4	5	15	5.8	10.5	2.2

- KP-30
- KP-35
- KP-40
- KP-50

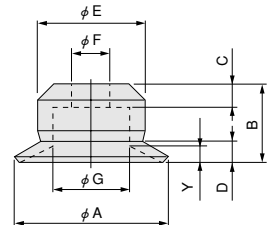

Model	Code	A	B	C	D	E	F	G	Y
KP-30		31	12	5	5	15	5.8	10.2	2.6
KP-35		35	14	6	5	15	5.8	10.2	1.6
KP-40		40.5	14	6	6	16	5.8	10.2	3.2
KP-50		50.5	15	6.5	7	24	8	20	2.9

- KPP-10

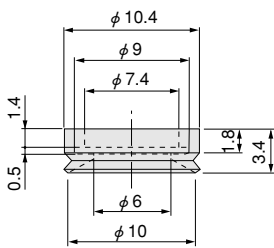

- KPP-15

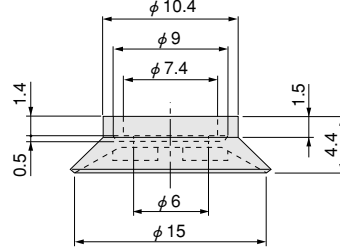

- KPP-20
- KPP-25
- KPP-30
- KPP-35

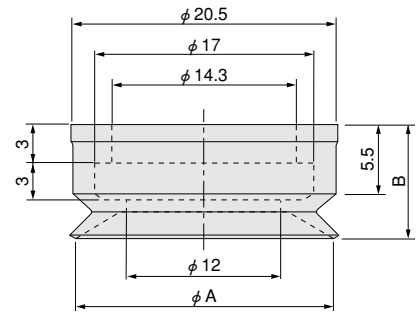

Model	Code	A	B
KPP-20		20	9
KPP-25		25	9
KPP-30		30	10.5
KPP-35		35	10.5

- KPP-40
- KPP-50
- KP-60
- KP-80
- KP-95
- KP-100

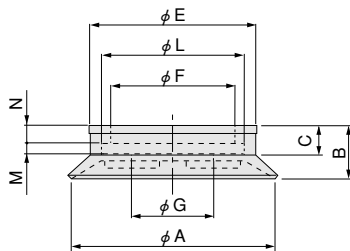

Model	Code	A	B	C	E	F	G	L	M	N
KPP-40		40	10.5	5.7	32.5	24.3	16	28	2	3.5
KPP-50		50	12	5.9	32.5	24.3	16	28	2	3.5
KP-60		60	15	7	60.5	48.3	26	54	3	4
KP-80		80	18	10	60.5	48.3	26	54	3	4
KP-95		95	21	8.4	60.5	48.3	26	54	3	4
KP-100		100	22	8	60.5	48.3	26	54	3	4

- KP-120
- KP-150
- KP-200

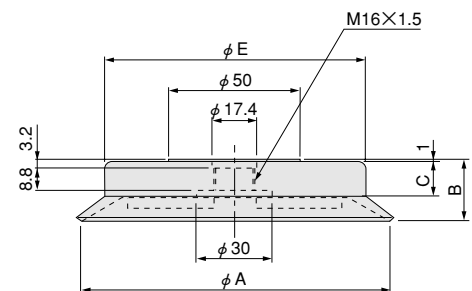

Model	Code	A	B	C	E
KP-120		120	24	13.3	100
KP-150		150	27	10.4	100
KP-200		200	32	11.9	146



● 2, 3.5  
2×4, 3.5×7

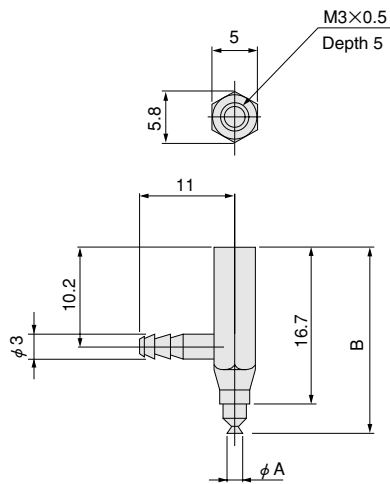

Pad model	Item	Pad diameter A	Overall length B	Applicable tube size
Round pad	KPHF-2	$\phi$ 2.5	20	Urethane tube 4×2.5
	KPHF-3.5	$\phi$ 3.5	20.2	
Oval pad	KPHF-2×4	2×4	20.7	
	KPHF-3.5×7	3.5×7	21.2	

● 6, 8

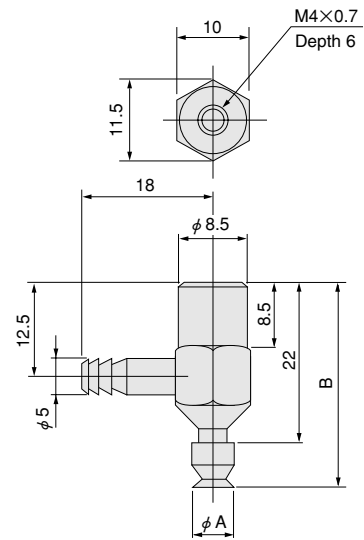

Pad model	Item	Pad diameter A	Overall length B	Applicable tube size
Round pad	KPHF-6	6	28	Urethane tube 6×4
	KPHF-8	8	27.5	

● 10, 15, 20

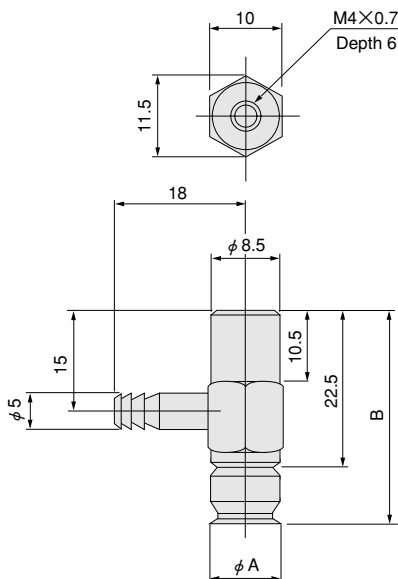

Pad model	Item	Pad diameter A	Overall length B	Applicable tube size	
Round pad	KPHF-10	10	30.5	Urethane tube 6×4	
	KPHF-15	15	30.5		
	KPHF-20		20		32.5

● 25, 30, 35, 40, 50

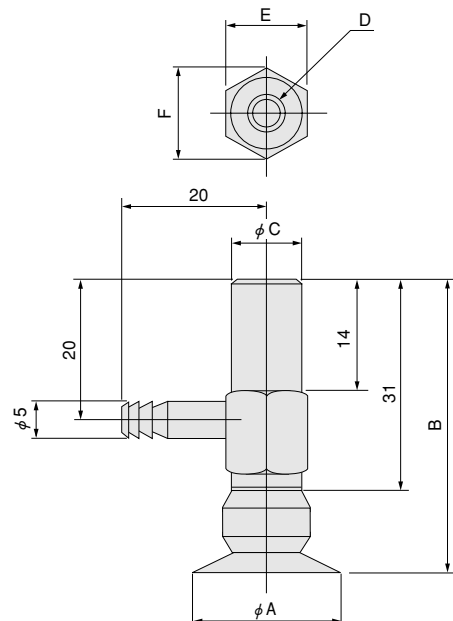

Pad model	Item	Pad diameter A	Overall length B	C	D	E	F	Applicable tube size
Round pad	KPHF-25	25	45	11	M5×0.8 Depth 10	12	13.9	Urethane tube 6×4
	KPHF-30	30	43					
	KPHF-35	35	45	12	M8×1 Depth 12	14	16.2	
	KPHF-40	40	45					
	KPHF-50	50	47					



● 60, 80, 95, 100

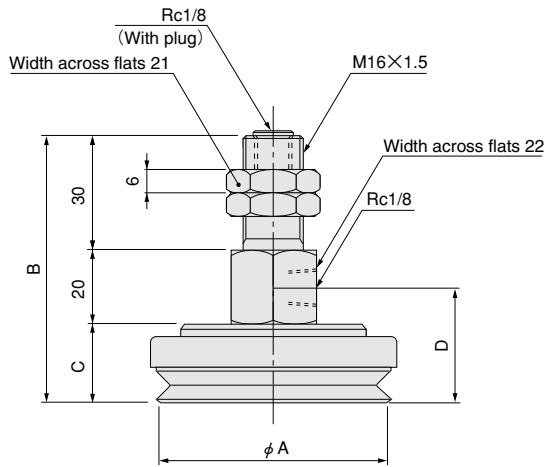

Pad model	Item	Pad diameter A	Overall length B	Pad length C	Piping port location D
Round pad	KPHF-60	60	70	20	30
	KPHF-80	80	73	23	33
	KPHF-95	95	76	26	36
	KPHF-100	100	77	27	37

Remark: Changing the location of the plug allows for vertical pipe installation use.

● 120, 150, 200

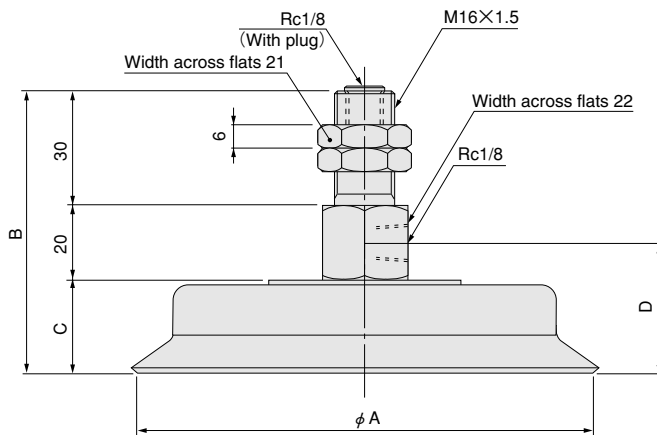

Pad model	Item	Pad diameter A	Overall length B	Pad length C	Piping port location D
Round pad	KPHF-120	120	74	24	34
	KPHF-150	150	77	27	37
	KPHF-200	200	82	32	42

Remark: Changing the location of the plug allows for vertical pipe installation use.

● 2, 3.5  
2×4, 3.5×7

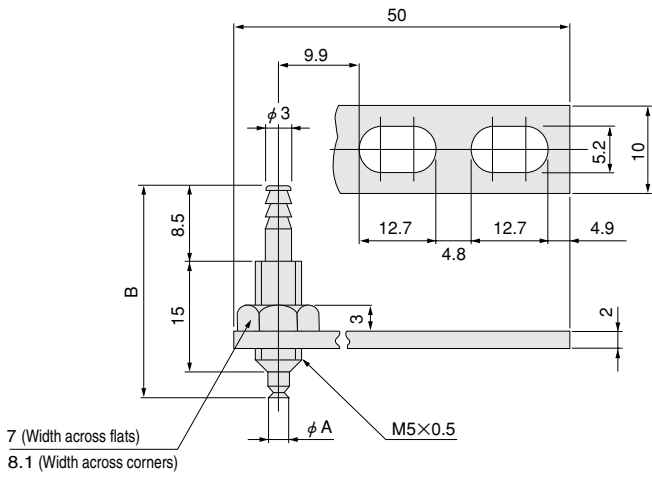

Pad model	Item	Pad diameter A	Overall length B	Applicable tube size
Round pad	KPVF-2	φ 2.5	26.8	Urethane tube 4×2.5
	KPVF-3.5	φ 3.5	27	
Oval pad	KPVF-2×4	2×4	27.5	
	KPVF-3.5×7	3.5×7	28	

● 6, 8

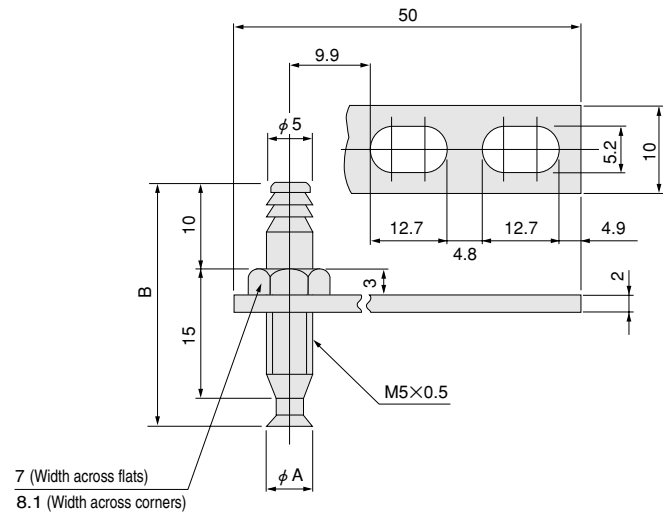

Pad model	Item	Pad diameter A	Overall length B	Applicable tube size
Round pad	KPVF-6	6	31	Urethane tube 6×4
	KPVF-8	8	30.5	

● 10, 15, 20

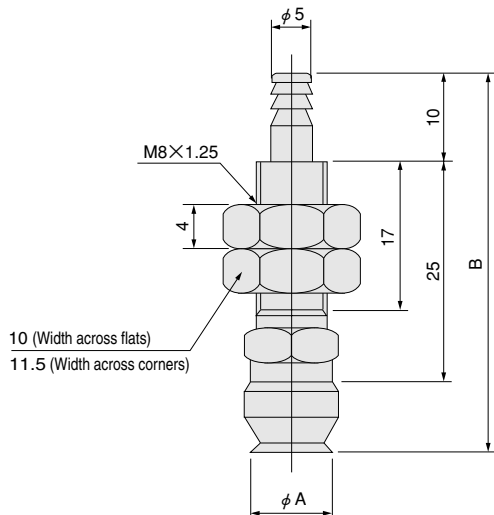

Pad model	Item	Pad diameter A	Overall length B	Applicable tube size
Round pad	KPVF-10	10	43	Urethane tube 6×4
	KPVF-15	15	43	
	KPVF-20	20	45	

● 25, 30, 35, 40, 50

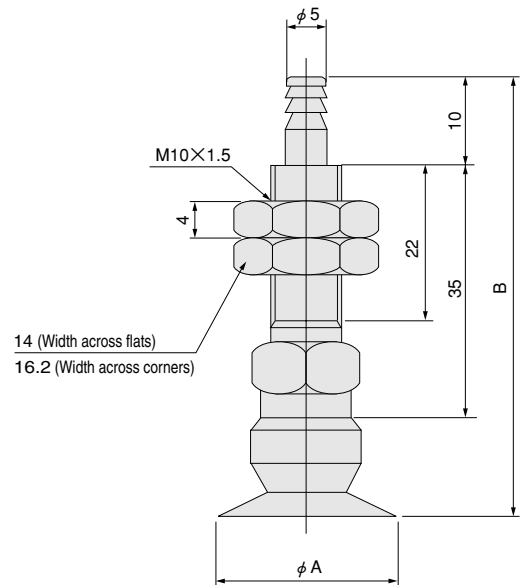

Pad model	Item	Pad diameter A	Overall length B	Applicable tube size
Round pad	KPVF-25	25	59	Urethane tube 6×4
	KPVF-30	30	58	
	KPVF-35	35	60	
	KPVF-40	40	60	
	KPVF-50	50	62	

● 10, 15

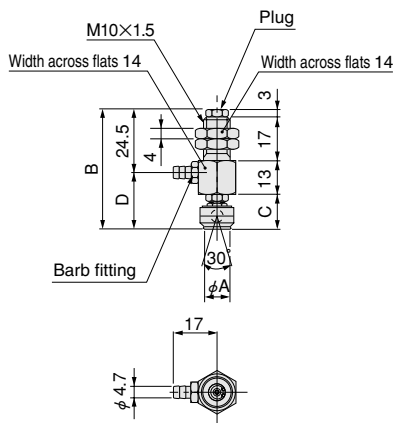

Pad model	Item	Pad diameter A	Overall length B	C	Piping port location D	Applicable tube size
Round pad	KPPF-10	10	46.5	13.5	22	Urethane tube 6x4
	KPPF-15	15	47.5	14.5	23	

Remark: Switching between the plug and barb fitting allows for vertical piping installation use.

● 40, 50

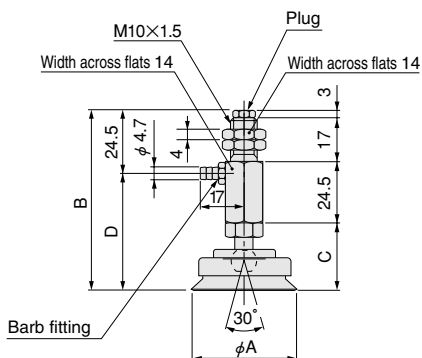

Pad model	Item	Pad diameter A	Overall length B	C	Piping port location D	Applicable tube size
Round pad	KPPF-40	40	71	26.5	46.5	Urethane tube 6x4
	KPPF-50	50	72.5	28	48	

Remark: Switching between the plug and barb fitting allows for vertical piping installation use.

● 20, 25, 30, 35

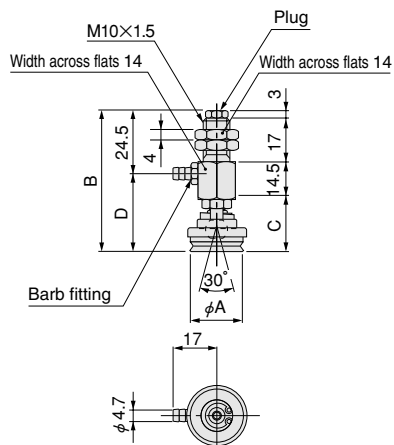

Pad model	Item	Pad diameter A	Overall length B	C	Piping port location D	Applicable tube size
Round pad	KPPF-20	20	55	20.5	30.5	Urethane tube 6x4
	KPPF-25	25				
	KPPF-30	30	56.5	22	32	
	KPPF-35	35				

Remark: Switching between the plug and barb fitting allows for vertical piping installation use.

● 60, 80

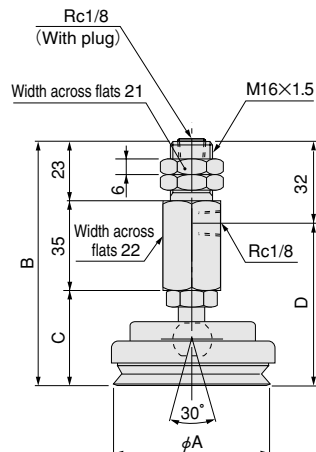

Pad model	Item	Pad diameter A	Overall length B	C	Piping port location D
Round pad	KPPF-60	60	96	38	64
	KPPF-80	80	99	41	67

Remark: Changing the location of the plug allows for vertical pipe installation use.

- 6, 8, 10
- 2×4
- 3.5×7
- 4×10
- 5×10
- 6×10

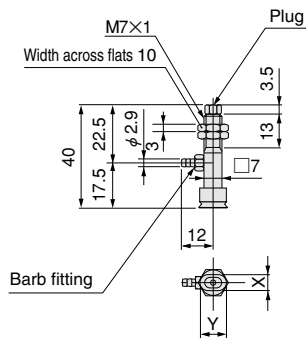

- 4×20
- 5×20
- 6×20
- 8×20
- 4×30
- 5×30
- 6×30
- 8×30

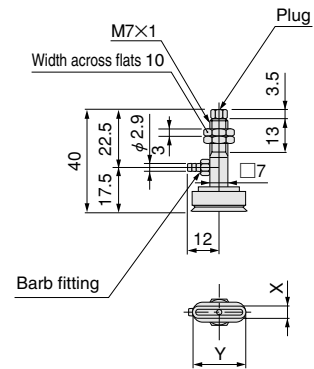

Pad model	Item	Pad diameter X × Y	Applicable tube size
Round pad	KPLF-6	φ 6	Urethane tube 4×2.5
	KPLF-8	φ 8	
	KPLF-10	φ 10	
Oval pad	KPLF-2×4	2×4	
	KPLF-3.5×7	3.5×7	
	KPLF-4×10	4×10	
	KPLF-5×10	5×10	
	KPLF-6×10	6×10	

Remark: Switching between the plug and barb fitting allows for vertical piping installation use.

Pad model	Item	Pad diameter X × Y	Applicable tube size
Oval pad	KPLF-4×20	4×20	Urethane tube 4×2.5
	KPLF-5×20	5×20	
	KPLF-6×20	6×20	
	KPLF-8×20	8×20	
	KPLF-4×30	4×30	
	KPLF-5×30	5×30	
	KPLF-6×30	6×30	
	KPLF-8×30	8×30	

Remark: Switching between the plug and barb fitting allows for vertical piping installation use.

● 2, 3.5  
2×4, 3.5×7

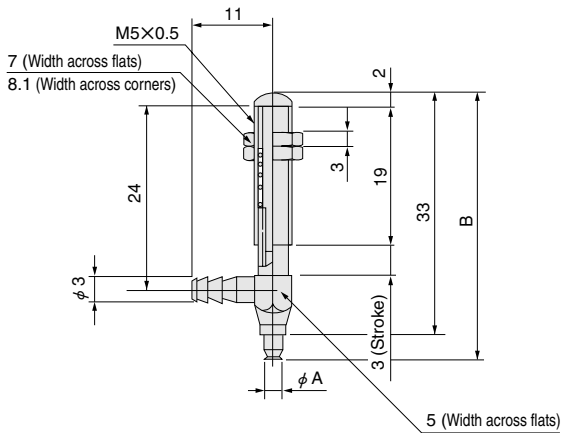

Pad model	Item	Pad diameter A	Overall length B	Applicable tube size	Spring stroke
Round pad	KPHS-2	φ 2.5	36	Urethane tube 4×2.5	3
	KPHS-3.5	φ 3.5	36.2		
Oval pad	KPHS-2×4	2×4	36.7		
	KPHS-3.5×7	3.5×7	37.2		

● 6, 8

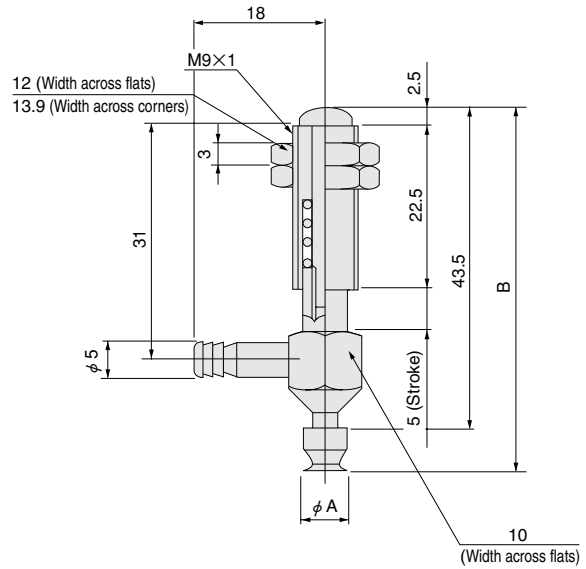

Pad model	Item	Pad diameter A	Overall length B	Applicable tube size	Spring stroke
Round pad	KPHS-6	6	50	Urethane tube 6×4	5
	KPHS-8	8	49.5		

● 10, 15, 20

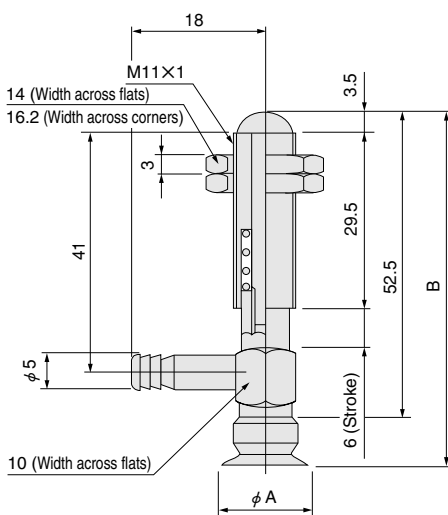

Pad model	Item	Pad diameter A	Overall length B	Applicable tube size	Spring stroke
Round pad	KPHS-10	10	60.5	Urethane tube 6×4	6
	KPHS-15	15	60.5		
	KPHS-20	20	62.5		

● 25, 30, 35, 40, 50

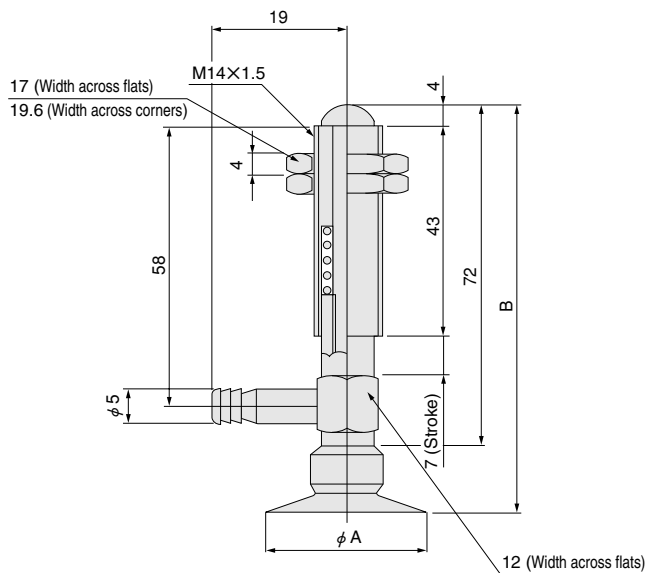

Pad model	Item	Pad diameter A	Overall length B	Applicable tube size	Spring stroke
Round pad	KPHS-25	25	85	Urethane tube 6×4	7
	KPHS-30	30	83		
	KPHS-35	35	85		
	KPHS-40	40	85		
	KPHS-50	50	87		

●60, 80, 95, 100

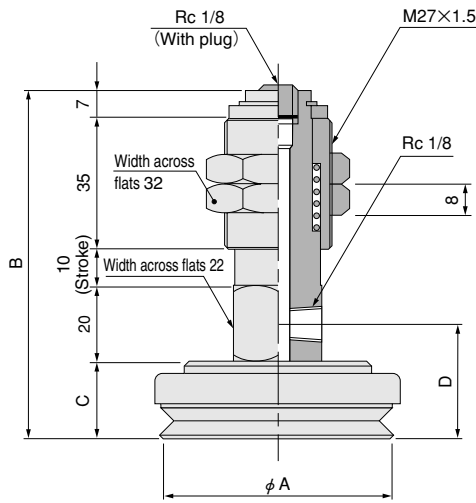

Pad model	Item	Pad diameter A	Overall length B	Pad height C	Piping port location D	Spring stroke
Round pad	KPHS-60	60	92	20	30	10
	KPHS-80	80	95	23	33	
	KPHS-95	95	98	26	36	
	KPHS-100	100	99	27	37	

Remark: Changing the location of the plug allows for vertical pipe installation use.

●120, 150, 200

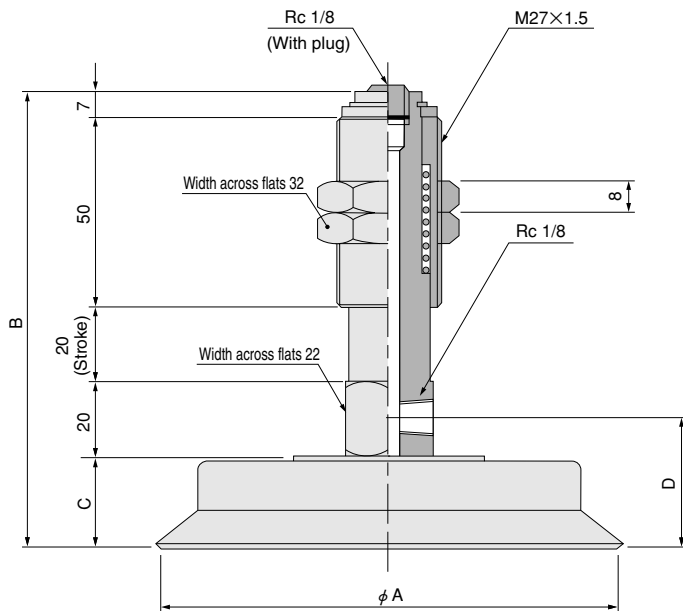

Pad model	Item	Pad diameter A	Overall length B	Pad height C	Piping port location D	Spring stroke
Round pad	KPHS-120	120	121	24	34	20
	KPHS-150	150	124	27	37	
	KPHS-200	200	129	32	42	

Remark: Changing the location of the plug allows for vertical pipe installation use.

● 2, 3.5  
2×4, 3.5×7

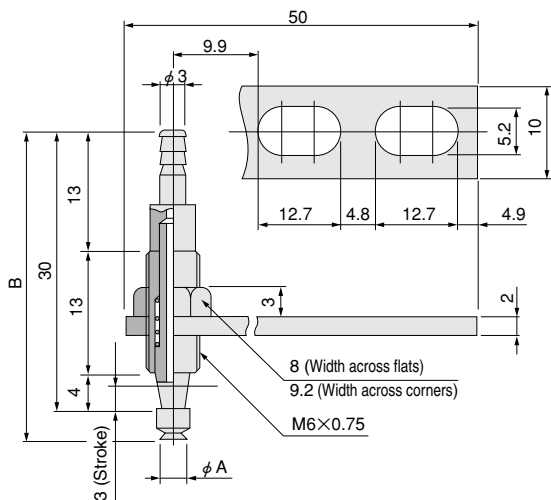

● 6, 8

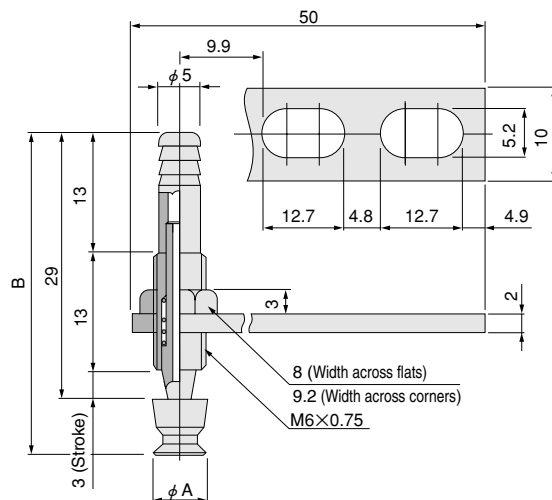

Pad model	Item	Pad diameter A	Overall length B	Applicable tube size	Spring stroke
Round pad	KPVS-2	φ 2.5	33.3	Urethane tube 4×2.5	3
	KPVS-3.5	φ 3.5	33.5		
Oval pad	KPVS-2×4	2×4	34		
	KPVS-3.5×7	3.5×7	34.5		

Pad model	Item	Pad diameter A	Overall length B	Applicable tube size	Spring stroke
Round pad	KPVS-6	6	35	Urethane tube 6×4	3
	KPVS-8	8	34.5		

● 10, 15, 20

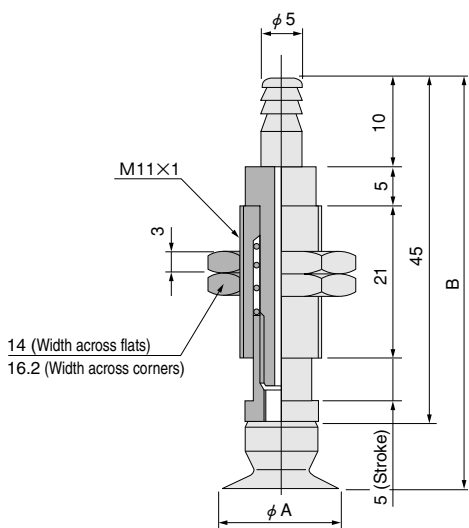

● 25, 30, 35, 40, 50

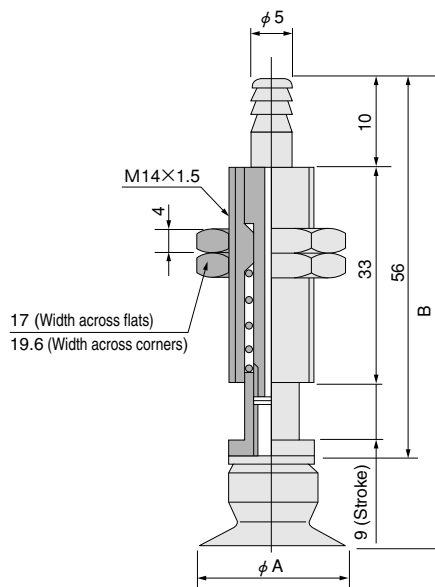

Pad model	Item	Pad diameter A	Overall length B	Applicable tube size	Spring stroke
Round pad	KPVS-10	10	53	Urethane tube 6×4	5
	KPVS-15	15	53		
	KPVS-20	20	55		

Pad model	Item	Pad diameter A	Overall length B	Applicable tube size	Spring stroke
Round pad	KPVS-25	25	70	Urethane tube 6×4	9
	KPVS-30	30	68		
	KPVS-35	35	70		
	KPVS-40	40	70		
	KPVS-50	50	72		

● 10, 15

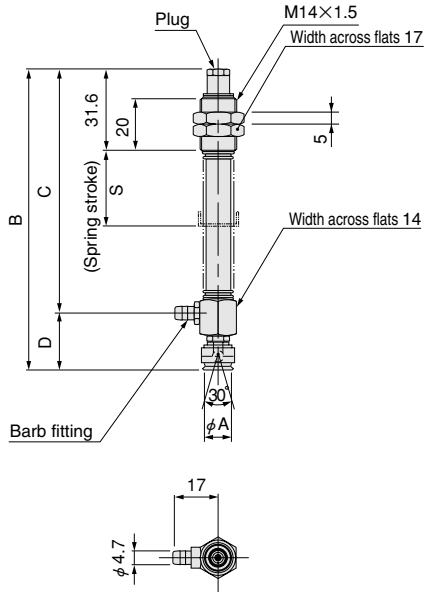

Pad model	Item	Pad diameter A	Spring stroke S	Overall length B	C	Piping port location D	Applicable tube size
Round pad	KPPS-10	10	5	69.5	47.5	22	Urethane tube 6×4
			10	78.5	56.5		
			20	96.5	76.5		
	KPPS-15	15	5	70.5	47.5	23	
			10	79.5	56.5		
			20	99.5	76.5		
		30	119.5	96.5			

Remark: Switching between the plug and barb fitting allows for vertical piping installation use.

● 20, 25, 30, 35

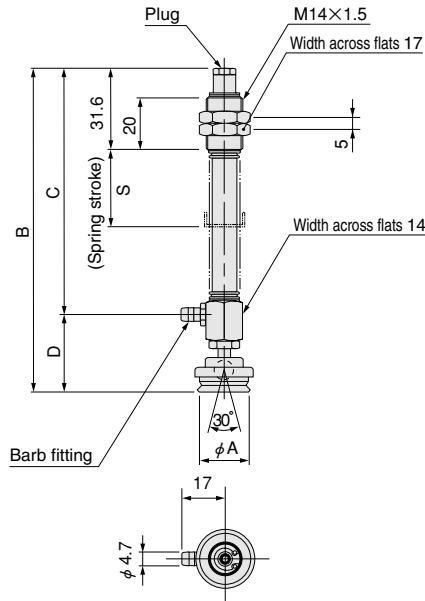

Pad model	Item	Pad diameter A	Spring stroke S	Overall length B	C	Piping port location D	Applicable tube size
Round pad	KPPS-20	20	10	87	56.5	30.5	Urethane tube 6×4
			20	107	76.5		
			30	127	96.5		
	KPPS-30	30	10	88.5	56.5	32	
			20	108.5	76.5		
			30	128.5	96.5		
		35	168.5	136.5			

Remark: Switching between the plug and barb fitting allows for vertical piping installation use.

● 40, 50

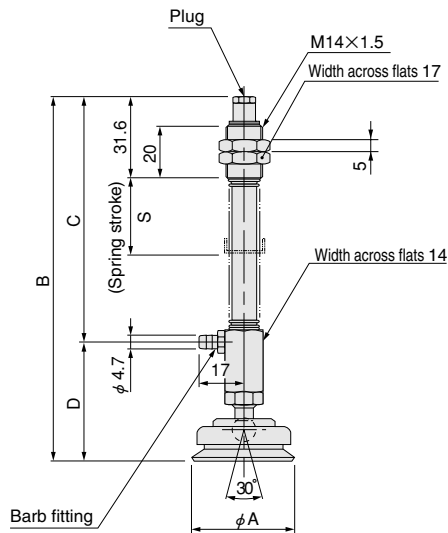

Pad model	Item	Pad diameter A	Spring stroke S	Overall length B	C	Piping port location D	Applicable tube size
Round pad	KPPS-40	40	10	103	56.5	46.5	Urethane tube 6×4
			20	123	76.5		
			30	143	96.5		
	KPPS-50	50	10	104.5	56.5	48	
			20	124.5	76.5		
			30	144.5	96.5		
		50	184.5	136.5			

Remark: Switching between the plug and barb fitting allows for vertical piping installation use.

● 60, 80

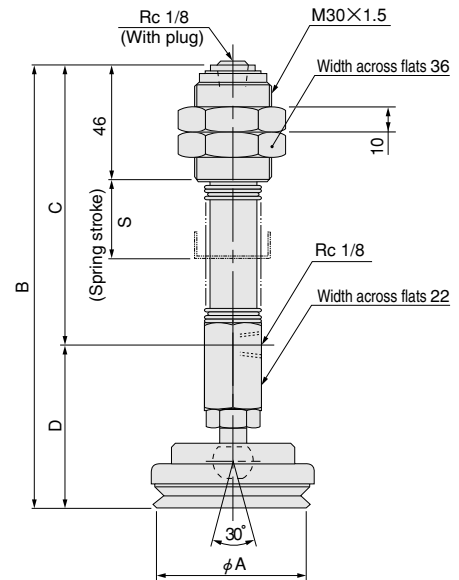

Pad model	Item	Pad diameter A	Spring stroke S	Overall length B	C	Piping port location D	Applicable tube size
Round pad	KPPS-60	60	10	138	74	64	Urethane tube 6×4
			30	174	110		
			50	204	140		
	KPPS-80	80	10	141	74	67	
			30	177	110		
			50	207	140		
		70	237	170			

Remark: Changing the location of the plug allows for vertical pipe installation use.



# Dimensions of KPLS (mm)

- 6, 8, 10
- 2×4
- 3.5×7
- 4×10
- 5×10
- 6×10

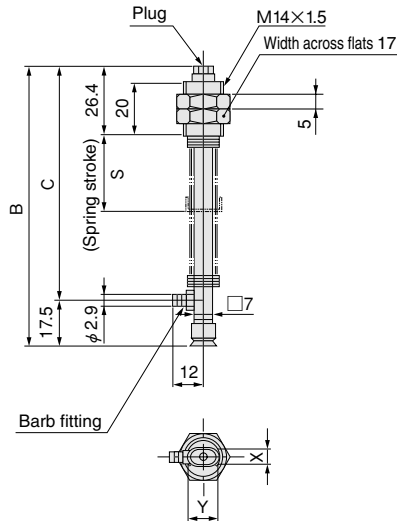

Pad model	Item	Pad diameter X×Y	Spring stroke S	Overall length B	C	Applicable tube size
Round pad	KPLS-6	φ 6	5	59	41.5	Urethane tube 4×2.5
	KPLS-8	φ 8	10	69	51.5	
	KPLS-10	φ 10	20	89	71.5	
Oval pad	KPLS-2×4	2×4	5	59	41.5	
	KPLS-3.5×7	3.5×7	10	69	51.5	
	KPLS-4×10	4×10	20	89	71.5	
	KPLS-5×10	5×10	30	109	91.5	
	KPLS-6×10	6×10	30	109	91.5	

Remark: Switching between the plug and barb fitting allows for vertical piping installation use.

- 4×20
- 5×20
- 6×20
- 8×20
- 4×30
- 5×30
- 6×30
- 8×30

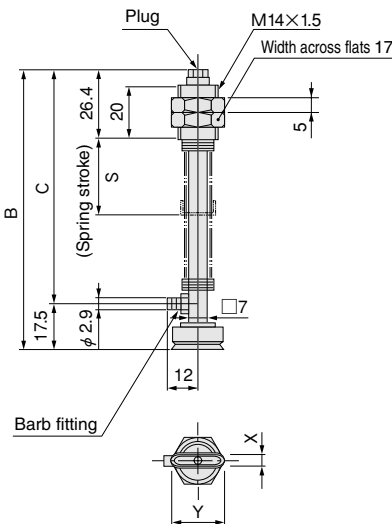

Pad model	Item	Pad diameter X×Y	Spring stroke S	Overall length B	C	Applicable tube size
Oval pad	KPLS-4×20	4×20	5	59	41.5	Urethane tube 4×2.5
	KPLS-5×20	5×20				
	KPLS-6×20	6×20	10	69	51.5	
	KPLS-8×20	8×20				
	KPLS-4×30	4×30	20	89	71.5	
	KPLS-5×30	5×30				
	KPLS-6×30	6×30	30	109	91.5	
	KPLS-8×30	8×30				

Remark: Switching between the plug and barb fitting allows for vertical piping installation use.

# Dimensions of Rubber Pad Mounting Portion (mm)

- KP-2
- KP-3.5
- KP-2×4
- KP-3.5×7

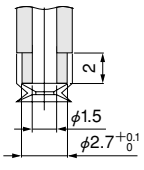

- KP-6
- KP-8

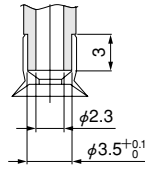

- KP-10

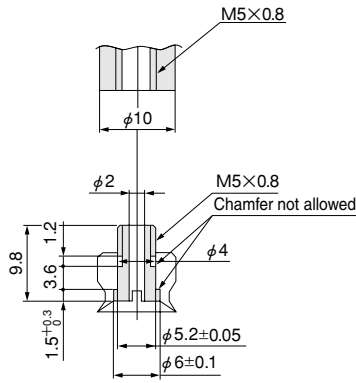

- KP-15
- KP-20

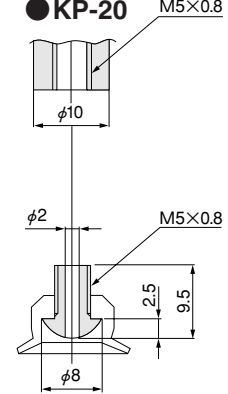

- KP-25
- KP-30
- KP-35
- KP-40

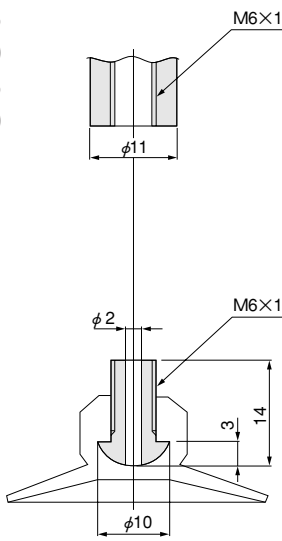

- KP-50

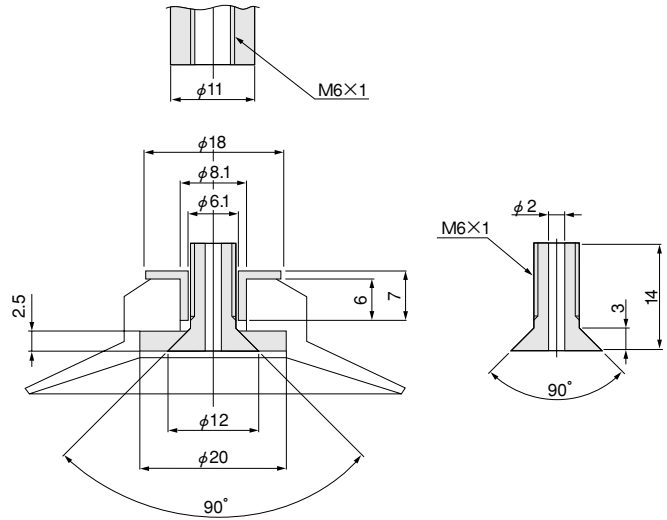

- KPL-4×20~8×30

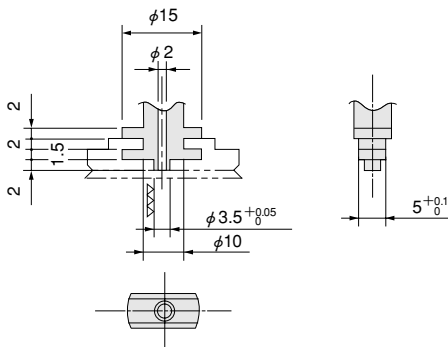

- KPL-6~10
- KPL-2×4~6×10

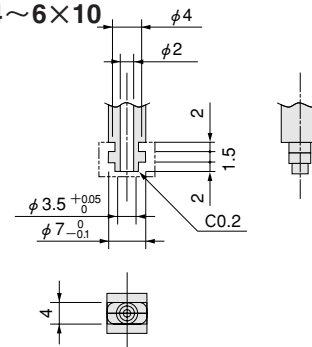

- KP-60, 80
- KPP-95, 100

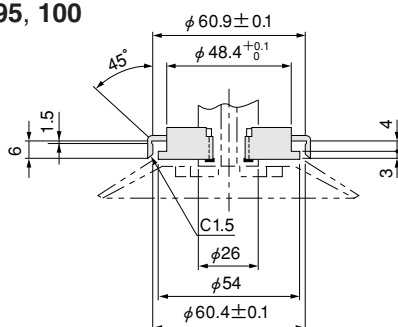

- KP-120~200

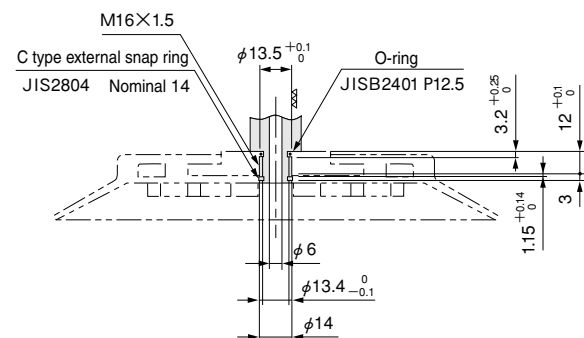

● KPP-10, 15

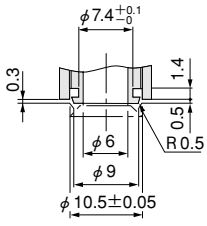

● KPP-20~35

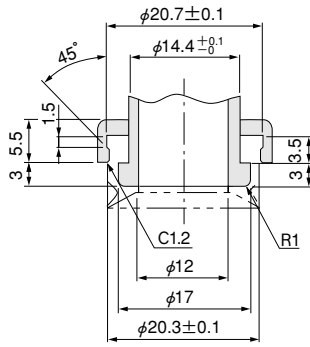

● KPP-40, 50

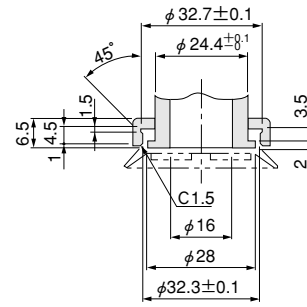

# Handling Instructions and Precautions



Vacuum pad

### Piping

To reduce piping resistance, keep the piping length as short and straight as possible, and avoid use of spiral piping.

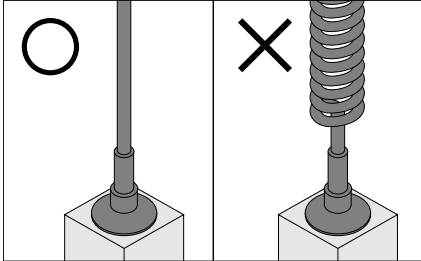

### Mounting position

In principle, use perpendicular lifting, and avoid slanted or parallel lifting if at all possible. If such an application cannot be avoided, ensure adequate safety margins. (For details, see p.615)

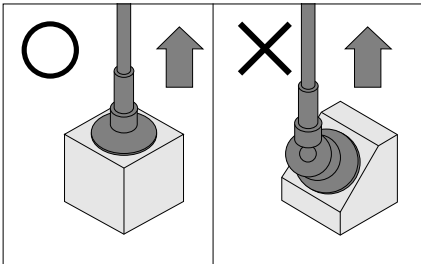

### Storage

1. The vacuum pad (including rubber pad) uses various kinds of rubber. The rubber can deteriorate due to direct sunlight, oil, water, and ozone, etc. Before use, always store it indoors, sealed in a polyethylene bag.
2. Maintain the storage temperature at room temperature.
3. Limit storage to two years from the date of manufacture.

### Replacement of rubber pad

When replacing the rubber pad, refer to the dimensions of rubber pad mounting portion to remove the rubber pad, screw, and mounting body, etc., and then replace the rubber pad. When assembling the mounting body to rubber pad KP-15 to KP-40, slowly screw the mounting screw to assemble the mounting body and rubber pad. To securely tighten, rotate the mounting screw by one-half turn (180°) further after they are closely contacted. Note that the rubber pad mounting screw differs for each rubber pad size, from KP-10 to KP-50. For details, see "Dimensions of Rubber Pad Mounting Portion." (For details, consult us.)

### General precautions

1. Use one vacuum pad for one micro ejector unit. Use of two or more vacuum pads could result in picking errors, and extend the amount of time required to reach the set vacuum level.

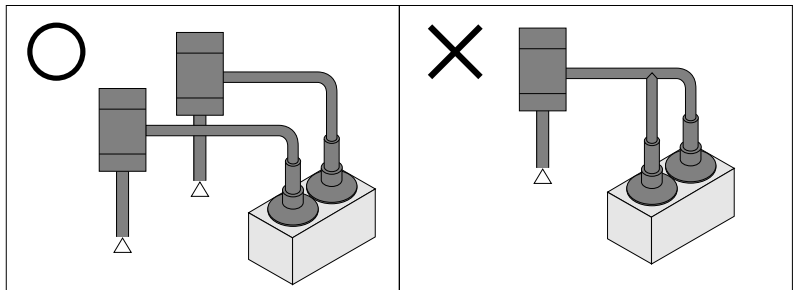

2. When connecting piping to the spring type vacuum pad with mounting body, be careful to avoid applying excessive force to the body, as it could result in defective spring operation or in wear on moving parts.

### Tightening torque

When mounting a vacuum pad, use the values in the table to the right for the nut tightening torque.

Model	Thread	Tightening torque N · cm [in · lbf]
KPHF-2~3.5×7	M3×0.5	29 [2.57]
KPHF-6, 8	M4×0.7	69 [6.11]
KPHF-10, 20	M4×0.7	69 [6.11]
KPHF-25, 30	M5×0.8	147 [13.0]
KPHF-35~50	M8×1	686 [60.7]
KPHF-60~200	M16×1.5	5884 [521]
KPVF-2~3.5×7	M5×0.5	343 [30.4]
KPVF-6, 8	M5×0.5	343 [30.4]
KPVF-10~20	M8×1.25	686 [60.7]
KPVF-25~50	M10×1.5	2157 [191]
KPPF-10~50	M10×1.5	883 [78.2]
KPPF-60, 80	M16×1.5	5884 [521]
KPPF- All types	M7×1	588 [52.0]
KPHS-2~3.5×7	M5×0.5	59 [5.22]
KPHS-6, 8	M9×1	686 [60.7]
KPHS-10~20	M11×1	883 [78.2]
KPHS-25~50	M14×1.5	1275 [113]
KPHS-60~200	M27×1.5	19613 [1736]
KPVS-2~3.5×7	M6×0.75	196 [17.3]
KPVS-6, 8	M6×0.75	196 [17.3]
KPVS-10~20	M11×1	883 [78.2]
KPVS-25~50	M14×1.5	1275 [113]
KPPS-10~50	M14×1.5	2942 [260]
KPPS-60, 80	M30×1.5	29420 [2604]
KPLS- All types	M14×1.5	1275 [113]