

# DIGITAL PRESSURE SWITCHES

## GS6 Series

### Two-screen, Three-color Display Makes Operations Simple!

Allows you to check the “current value” and the “threshold value” at the same time!

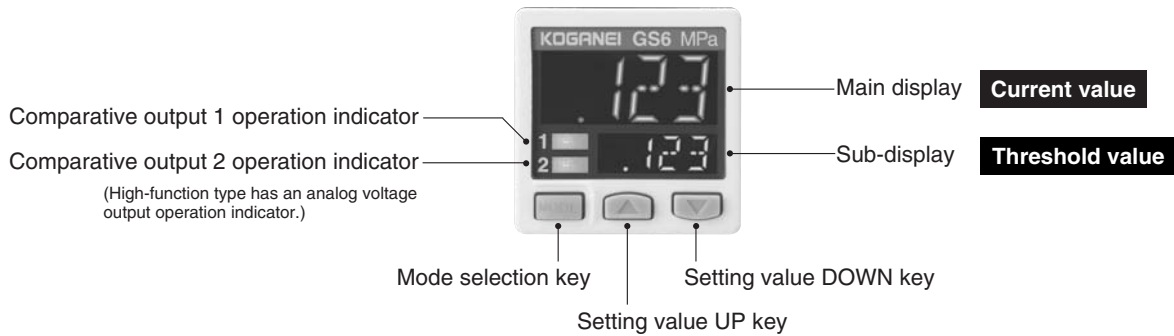

#### Three-color display (Red/Green/Orange)

The main display changes color in line with output ON/OFF operations, and can also change color during settings. This simplifies the operator’s grasp of pressure switch conditions, to reduce operating errors.

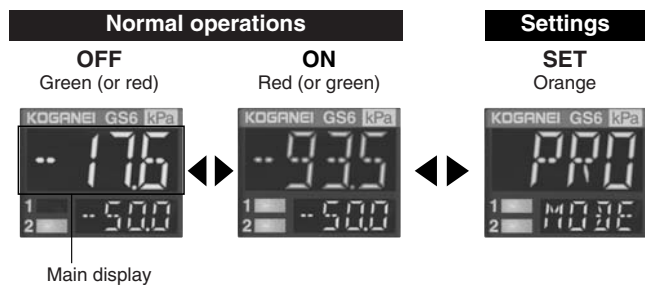

#### Easy to read! Digital display

An alphanumeric display with 12 segments is used, for improved visibility of the alphanumeric characters.

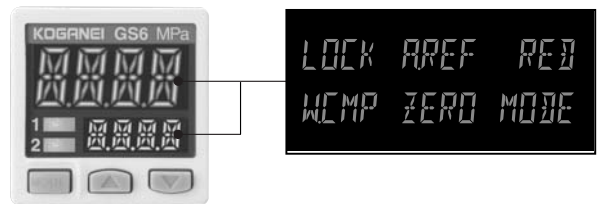

PRESSURE SWITCHES

### Direct Setting of Threshold Values

Comes with two screens in a 30mm compact size. Since both the current value and threshold value can be checked at the same time, checking and setting the threshold value proceeds smoothly without the need to switch between screens. Since ON/OFF operations can proceed even during setting of the threshold value, the setting can be performed with the same way as a volume-knob style pressure switch. Naturally, a key lock function is also provided.

#### Previous single-screen model

Threshold value setting method

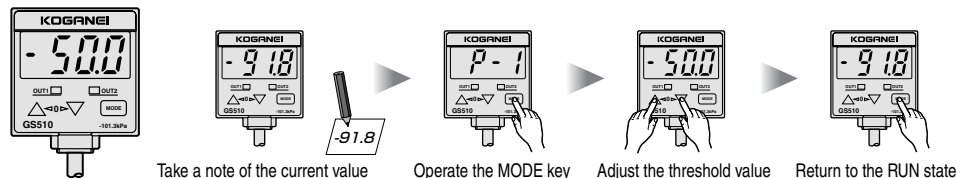

#### Two-screen GS6 series

Threshold value setting method



While in the RUN state, just press the button.

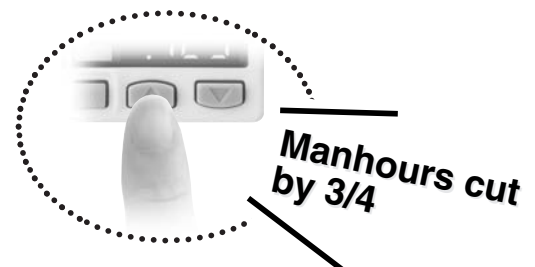

# Copy Function Offers Easy Operation

Copy function reduces manhours and human errors

Setting content of a master pressure switch can be copied via data transmission to other pressure switches by connecting them one at a time to the master pressure switch. This prevents problems arising due to setting mistakes when multiple switches are being set to the same setting, and also reduces the amount of changes required in the work instructions when design changes are made to devices.

**Merit 1** Shortens the pressure switch setting time

**Merit 2** Avoids operation errors

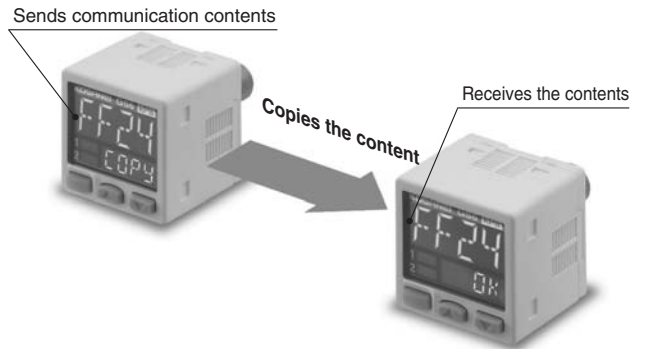
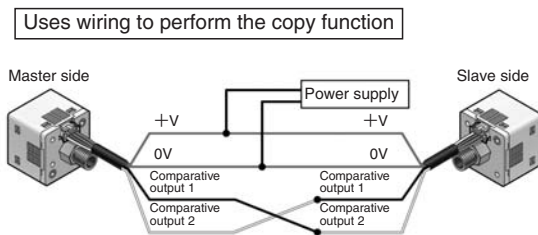

# Setting Is Simple and Smooth

Pressure switch operation mode can be set to three configuration levels depending on frequency of use

**RUN mode: Daily operation setting**

**Menu setting mode: Basic setting**

**PRO mode: High-level function setting**



Enables threshold value adjustment, key lock, and other actions during operations.



Enables output mode setting, N.O./N.C. switching, and other basic settings.



Enables hysteresis adjustment, copy function, and other high-level function settings.

## Initial setting can be used unchanged

The initial setting is made to be easy to use for applications where pressure switches are used frequently. The initial setting for the low pressure type is optimum for vacuum holding check, while the one for the high pressure type is optimum for source pressure check. This helps to reduce pressure switch setting operations.

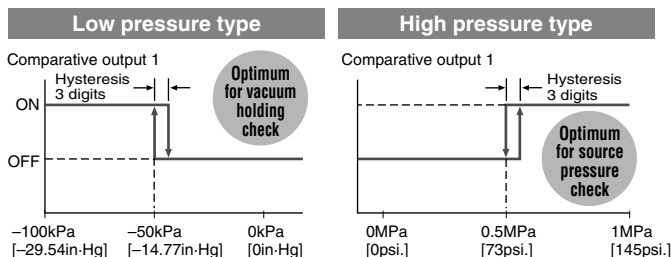

## Tactile click buttons

Buttons are designed for a tactile click when touched, to smooth the setting operations.



**This click can be felt even through gloves.**

## Reset function in case of setting failures

If the pressure switch setting fails for some reason, it automatically returns to the initial state.

# Performance and Functions Concentrated into a Compact Body

All models in the lineup are the compound pressure type

Since there is no need to select the pressure switch for positive or negative pressure, the registered product numbers can be reduced.

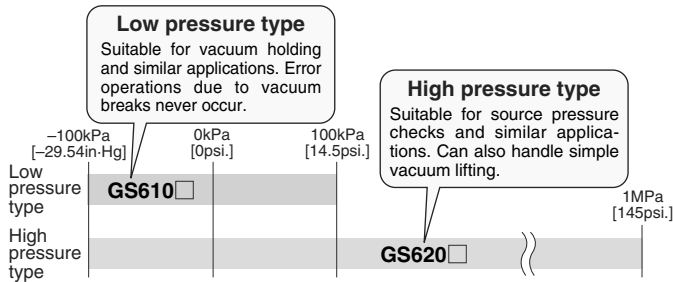

Achieves highest performance in its class

Low pressure type

The low pressure type has a resolution of 1/2000, in a 0.1kPa [0.0145psi.] unit display, and with a response time of 2.5ms (variable up to 5000ms), temperature characteristics of  $\pm 0.5\%$ F.S., and repeatability of  $\pm 0.1\%$ F.S., to achieve the highest performance in its class.

0.1kPa unit display

Resolution: 1/2000  
Response time: 2.5ms  
Temperature characteristics:  $\pm 0.5\%$ F.S.  
Repeatability:  $\pm 0.1\%$ F.S.



Equipped with two independent outputs

Standard type

Equipped with two independent comparative outputs, and the sensing mode can be separately selected for each. One of the comparative outputs can be used as a warning output. Or, the unused output can also be disabled.

Can also check vacuum breaks during vacuum lifting application!

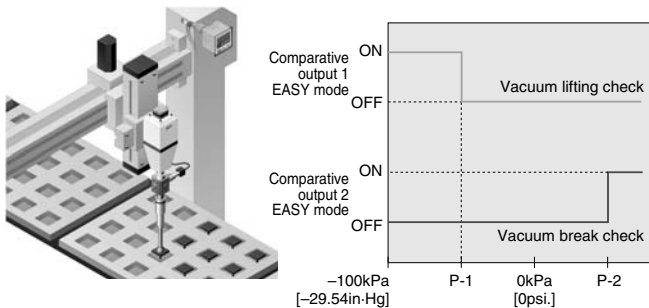

Can also produce pressure warning output during a source pressure check!

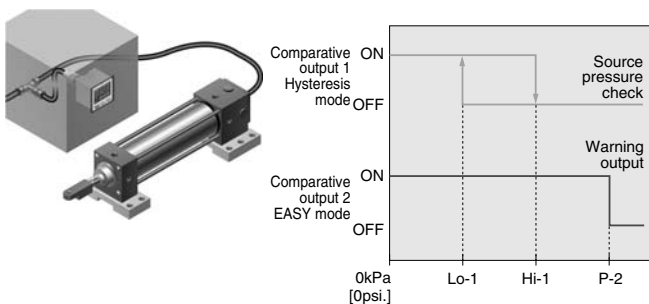

Three output modes offer response to a wide range of applications

## 1. EASY mode

ON / OFF of the comparative output is controlled in this mode.

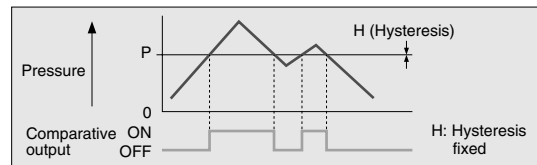

Notes: 1. Hysteresis can be fixed in eight steps.  
2. "P-1" is displayed for comparative output 1 and "P-2" for comparative output 2 on the sub-display.

## 2. Hysteresis mode

The comparative output ON / OFF state can be controlled with the desired set hysteresis in this mode.

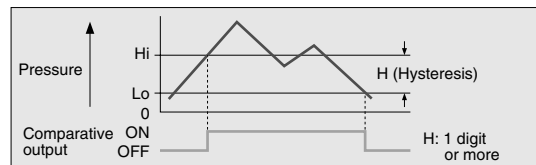

Note: "Hi - 1" or "Lo - 1" is displayed for comparative output 1 and "Hi - 2" or "Lo - 2" for comparative output 2 on the sub-display.

## 3. Window comparator mode

In this mode, the ON or OFF state of the comparative output is controlled with a pressure in the set range.

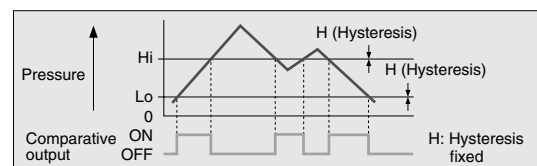

Notes: 1. Hysteresis can be fixed in eight steps.  
2. "Hi - 1" or "Lo - 1" is displayed for comparative output 1 and "Hi - 2" or "Lo - 2" for comparative output 2 on the sub-display.

## Can switch between analog output and external input High-function type

The high-function type offers selection between analog voltage output and external input (Auto-reference/Remote zero-adjustment). Capable of handling diverse applications.

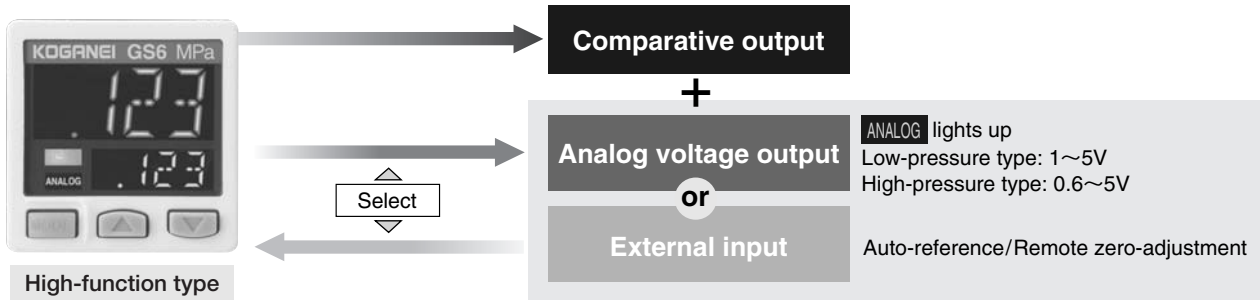

## Equipped with auto-reference/remote zero-adjustment functions High-function type

Achieves more precise high pressure control with minimum effort

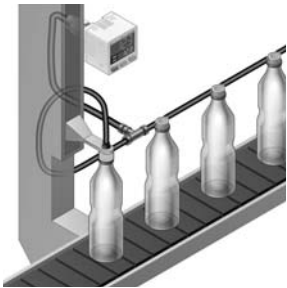

When the source pressure in devices is fluctuating, external input can be used to select between the auto-reference function, which shifts the comparative output judgment level to correct for source pressure fluctuation, and the remote zero-adjustment function, which corrects the display value to zero. Contributes greatly to use in locations with severe fluctuations of source pressure, or locations where precise settings are required.

### Without auto-reference/remote zero-adjustment functions

Comparative output: Hi-1...30, Lo-1...25  
Window comparator mode Setting value fixed

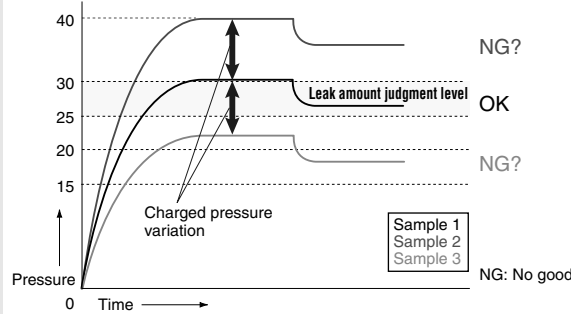

Since the judgment level is fixed in ordinary pressure switches, source pressure fluctuation can lead to judgment errors.

### When using the auto-reference function

Comparative output: Hi-1...0, Lo-1...-5  
Window comparator mode Sets the judgment level to the absolute amount

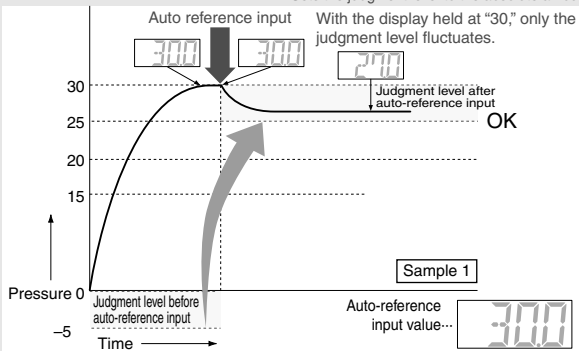

Adds the reference pressure "30" determined during auto-reference input to the judgment level. Even if the reference pressure changes to "20" or "40," the auto-reference input can be used to ignore the variation in charged pressure because of judgment level fluctuation.

### When using the remote zero-adjustment function

Comparative output: Hi-1...0, Lo-1...-5  
Window comparator mode Sets the judgment level to the absolute amount

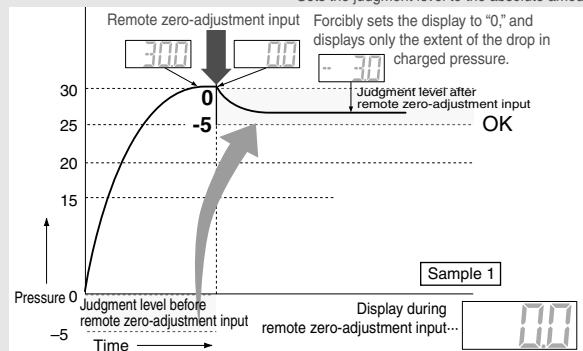

Forcibly sets the reference pressure determined during remote zero-adjustment input to "0." Even if the reference pressure changes to "20" or "40," the remote zero-adjustment input can be used to ignore the variation in charged pressure because the reference pressure becomes "0."

# Other Convenient Functions

## Customizing the sub-display

Other desired values and characters besides the threshold value can be displayed on the sub-display. This eliminates the effort required to post labels on the device showing the positive pressure value, etc.

### Displays desired values and characters

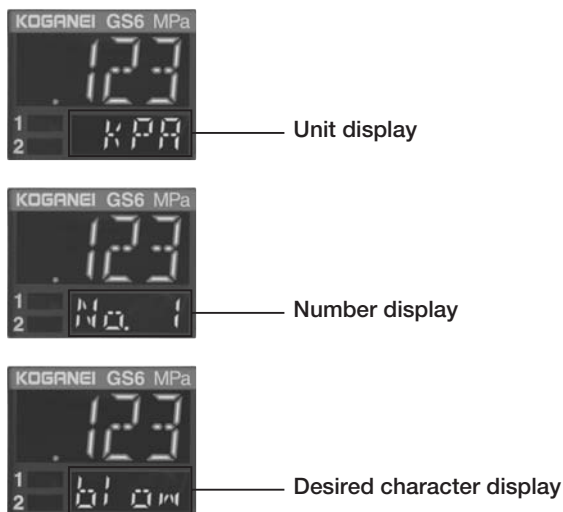

## Peak/bottom hold function

Uses two screens to display the peak value and bottom value of fluctuating pressure.

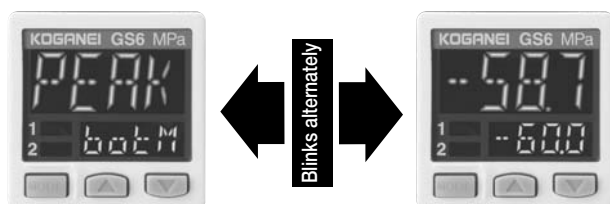

## Installation is also simple!

### Allows close mounting on panels

Optional part for mounting on a panel that is capable of handling panel thicknesses of 1 to 6mm [0.04 to 0.24in.] is available.

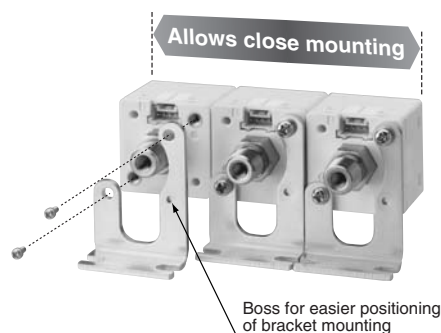
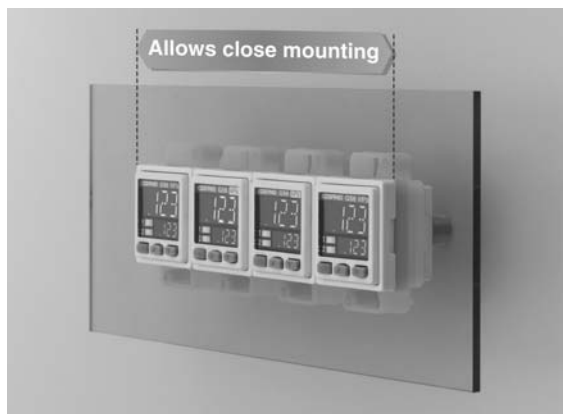

## Energy-saving design! ECO mode provided

Restricts brightness on display, to cut power consumption by 30%. Furthermore, shutting off lights on display can cut consumption by a maximum of about 40%.

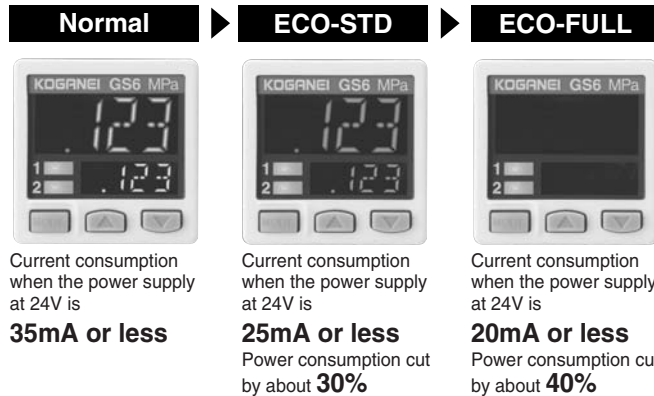

## Variable display update cycle

The display update cycle for the digital display can be changed in three steps: at 250ms, 500ms, and 1000ms. Extending the display update cycle can limit display flicker.

## Response time can be changed

The response time can be changed in 10 steps, from 2.5ms to 5000ms. This prevents chattering or erratic operation due to sudden changes in pressure.

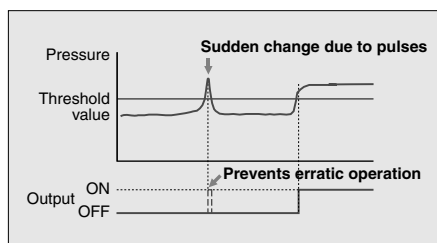

# Handling Instructions and Precautions



## General precautions

### Wiring

1. Make sure that the power supply is off while wiring.
2. Verify that the supply voltage variation is within the rating.
3. If power is supplied from a commercial switching regulator, ensure that the frame ground (F.G.) terminal of the power supply is connected to an actual ground.
4. When noise generating equipment (switching regulator, inverter motor, etc.) is used in the vicinity of pressure switch mounting portion, connect the frame ground (F.G.) terminal of the equipment to an actual ground.
5. Do not run the wires together with high-voltage lines or power lines or put them in the same conduit. This can cause malfunction due to induction.
6. Take care that wrong wiring will damage the sensor.
7. When wiring is completed, check that there is no error in the wiring connections.

### Connections

Do not apply stress directly to the cable leads or connectors.

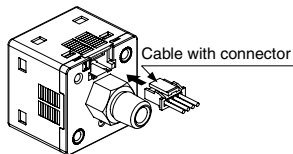

### Mounting

1. The sensor mounting bracket **GS6-B** (optional) is available. When mounting the sensor onto the sensor mounting bracket, etc., the tightening torque should not exceed 0.5N·m [0.37ft·lb].

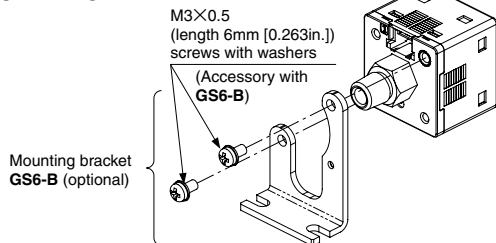

2. The parts for panel mounting **GS6-P** (optional) are also available.

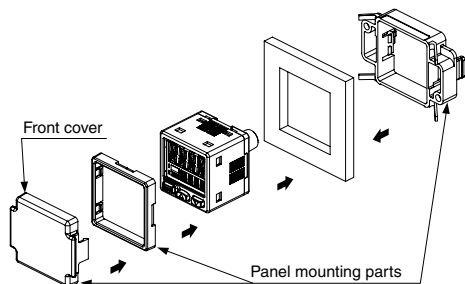

### Piping

When connecting a commercial fitting to the pressure port, apply a 12mm [0.472in.] spanner to the pressure port's hexagon section to secure the port, and then tighten with a tightening torque not exceeding 9.8N·m [7.23ft·lb] (M5 female: 1N·m [0.74ft·lb]). The commercial fitting or pressure port section will be damaged if the tightening torque is excessive. Wrap sealing tape around the fitting thread when connecting to prevent leaks.

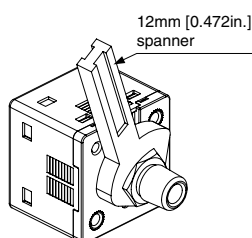

### Others

1. GS6 series is designed for use with non-corrosive gas. It cannot be used for liquid or corrosive gas.
2. Use within the rated pressure range.
3. Do not apply pressure exceeding the proof pressure value. The diaphragm will get damaged and correct operation shall not be maintained.
4. Do not use during the initial transient time (0.5 sec.) after the power supply is switched on.
5. Avoid dust, dirt, and steam in operating conditions.
6. Take care that the sensor does not come in direct contact with water, oil, grease, or organic solvents, such as thinner, etc.
7. Do not insert a wire, etc., into the pressure port. The diaphragm will get damaged and correct operation shall not be maintained.
8. Do not operate the keys with pointed or sharp objects.

### RUN mode

This is the normal operation mode.

Setting item	Description
Threshold value setting	Changes the ON/OFF threshold value merely by pressing the UP key or DOWN key.
Zero-adjustment function	Forcibly sets the pressure value to 'zero' when the pressure port vents to the atmosphere.
Key lock function	Rejects acceptance of key operations.
Peak/bottom hold function	Displays the peak value and bottom value of the fluctuating pressure. The peak value is displayed on the main display and the bottom value is displayed on the sub-display.

### Menu setting mode

1. When the mode selection key is held down for two seconds in the RUN mode, the menu setting mode will open.
2. The mode will change to the RUN mode when the mode selection key is held down during this setting process. In this case, the changed item is entered.

Setting item	Description
Comparative output 1 output mode setting	Sets the output mode of comparative output 1.
Comparative output 2 output mode setting (Standard type only)	Sets the output mode of comparative output 2.
Analog voltage output/external input selection (High-function type only)	Selects analog voltage output, auto-reference input, or remote zero-adjustment input.
N.O. / N.C. selection	Normal open (N.O.) or normal close (N.C.) can be selected.
Response time setting	Sets the response time. The response time can be selected from 2.5ms, 5ms, 10ms, 25ms, 50ms, 100ms, 250ms, 500ms, 1000ms or 5000ms.
Displayed color of the main display selection	Displayed color of the main indicator can be changed. Output ON/OFF can be designated either "red/green" or "green/red." The display can also permanently be fixed to "red" or "green."
Unit selection (High-pressure type only)	Pressure unit (MPa and kPa) can be changed.

Remarks: For details about each mode, function, or numerical setting, see the Owner's Manual supplied with the product.

# Input/Output Circuits and Connections

## I/O circuit diagrams

### ● Standard type

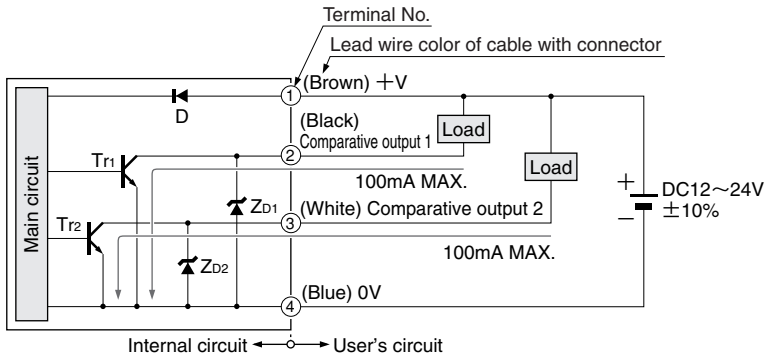

Key to codes... D: Reverse current protection diode for power supply  
 Z<sub>D1</sub>, Z<sub>D2</sub>: Zener diode for surge voltage absorption  
 T<sub>r1</sub>, T<sub>r2</sub>: NPN output transistor

### ● High-function type

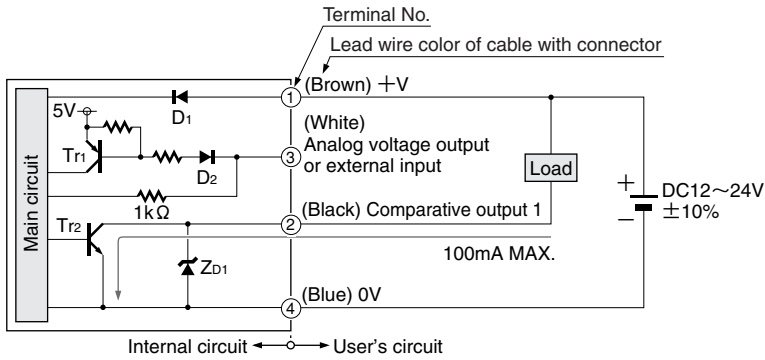

Key to codes... D: Reverse current protection diode for power supply  
 Z<sub>D1</sub>: Zener diode for surge voltage absorption  
 T<sub>r1</sub>: PNP input transistor  
 T<sub>r2</sub>: NPN output transistor

## Terminal arrangement diagram

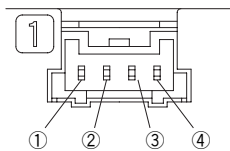

Terminal No.	Name
①	+V
②	Comparative output 1
③	Standard type: Comparative output 2 High-function type: Analog voltage output or external input
④	0V

# Specifications

Item	Type Model	Standard type		High-function type		
		Low pressure type	High pressure type	Low pressure type	High pressure type	
		GS610	GS620	GS610A	GS620A	
Pressure type	Gauge pressure					
Rated pressure range	-100.0 to +100.0kPa [-29.54in-Hg to 14.5psi.]	-0.100 to +1.000MPa [-29.54in-Hg to 145psi.]	-100.0 to +100.0kPa [-29.54in-Hg to 14.5psi.]	-0.100 to +1.000MPa [-29.54in-Hg to 145psi.]		
Set pressure range	-100.0 to +100.0kPa [-29.54in-Hg to 14.5psi.]	-0.100 to +1.000MPa [-29.54in-Hg to 145psi.]	-100.0 to +100.0kPa [-29.54in-Hg to 14.5psi.]	-0.100 to +1.000MPa [-29.54in-Hg to 145psi.]		
Proof pressure	500kPa [73psi.]	1.5MPa [218psi.]	500kPa [73psi.]	1.5MPa [218psi.]		
Applicable fluid	Non-corrosive gas					
Supply voltage	DC12 to 24V ±10%, Ripple P-P 10 % or less					
Power consumption	Normal operation: 840mW or less (current consumption 35mA or less at 24V supply voltage) ECO mode (STD): 600mW or less (current consumption 25mA or less at 24V supply voltage), ECO mode (FULL): 480mW or less (current consumption 20mA or less at 24V supply voltage)					
Comparative output	NPN open-collector transistor · Maximum sink current: 100mA · Applied voltage: DC30V or less (between comparative output and 0V) · Residual voltage: 0.5V or less (at sink current of 100mA, assuming a cable of 2m [6.56ft.] or less)					
	Output operation	Selectable either N.O. or N.C., with key operation				
	Output mode	EASY mode / hysteresis mode / window comparator mode				
	Hysteresis	Min. 1 digit (variable)				
	Repeatability	±0.1%F.S. (±within 2 digits)	±0.2%F.S. (±within 2 digits)	±0.1%F.S. (±within 2 digits)	±0.2%F.S. (±within 2 digits)	
	Response time	2.5ms, 5ms, 10ms, 25ms, 50ms, 100ms, 250ms, 500ms, 1000ms, or 5000ms selectable with key operations				
	Short-circuit protection	Equipped				
External input [Auto-reference function/Remote zero- adjustment function]	—		ON voltage: DC0.4V or less OFF voltage: DC5~30V or open Input impedance: 10kΩ approx. Input time: 1ms or more			
Analog voltage output	—		Output voltage: 1 to 5V Zero point: Within 3V±5% F.S. Span: Within 4V±5% F.S. Linearity: Within ±1% F.S. Output impedance: 1kΩ approx.	Output voltage: 0.6 to 5V Zero point: Within 1V±5% F.S. Span: Within 4.4V±5% F.S. Linearity: Within ±1% F.S. Output impedance: 1kΩ approx.		
Display	4 column+4 column 3 color LCD display (Display update cycle: 250ms, 500ms, or 1000ms, selectable with key operations)					
Display pressure range	-100.0 to +100.0kPa [-29.54in-Hg to 14.5psi.]	-0.100 to +1.000MPa [-29.54in-Hg to 145psi.]	-100.0 to +100.0kPa [-29.54in-Hg to 14.5psi.]	-0.100 to +1.000MPa [-29.54in-Hg to 145psi.]		
Indicator	Orange LED (Comparative output 1 operation indicator, Comparative output 2 operation indicator: Lights up when comparative output is ON)		Orange LED (Comparative output 1 operation indicator: Lights up when comparative output is ON, Analog voltage output operations indicator: Lights up when set)			
	IP40 (IEC)					
environment resistance	Ambient temperature: -10 to +50°C [14 to 122°F], Storage: -10 to +60°C [14 to 140°F]					
	Ambient humidity: 35 to 85%RH (No dew condensation or icing allowed), Storage: 35 to 85%RH					
	Dielectric strength: AC1000V 1 minute between charging part and case					
	Insulation resistance: At DC500V Megger, 50MΩ or more between charging part and case					
	Vibration resistance: Endurance 10 to 500Hz with total amplitude 3mm [0.118in.] in XYZ directions for 2 hours (When panel mounted: Endurance 10 to 150Hz with total amplitude 0.75mm [0.0295in.] in XYZ directions for 2 hours)					
	Shock resistance: Endurance 100m/s <sup>2</sup> (about 10G) in XYZ directions, three times					
Temperature characteristics	Within ±0.5%F.S. (+20°C [68°F] reference)	Within ±1%F.S. (+20°C [68°F] reference)	Within ±0.5%F.S. (+20°C [68°F] reference)	Within ±1%F.S. (+20°C [68°F] reference)		
Pressure port	M5×0.8 female thread and R1/8 male thread					
Material	Enclosure: PTB (with glass fiber), LCD display: Acrylic, Pressure port: Stainless steel (SUS303), Mounting screw section: Brass (nickel-plated), Switch: Silicone rubber					
Connection method	Connector connections					
Wiring length	Capable of up to 100m [328ft.] on a cable of 0.3mm <sup>2</sup> or larger					
Weight	40g [1.41oz.] approx.					
Accessories	Cable with a connector (cable length 2m [6.56ft.]): 1 pc.					

Note: If not specified, measurement condition assumes ambient temperature: +20°C [68°F].



# PRO Mode

- When the mode selection key is held down for five seconds in the RUN mode, the PRO mode will open.
- The mode will change to the RUN mode when the mode selection key is held down during this setting process. In this case, the changed item is entered.

Setting item	Description
Sub-display selection	Switches to desired alphanumeric characters on sub-display area during RUN mode.
Display update cycle switching	Switches the display update cycle for pressure value displayed on the main display area.
Hysteresis fixed value selection	Sets hysteresis of the EASY mode and the window comparator mode. (eight steps)
Displayed color change selection (Standard type only)	The displayed color for main display can be changed with either output operation of comparative output 1 or comparative output 2.
Eco mode setting	Darkens or switches off the display area to restrict power consumption.
Setting check code	Current setting contents can be checked.
Setting copy mode	The setting of the master pressure sensor can be copied to the slave side pressure sensors.
Reset setting	Returns to default settings (factory settings).

## Code table

Code	First digit		Second digit			Third digit	Fourth digit	
	Comparative output 1	N.O./N.C. selection	Comparative output 2	N.O./N.C. selection	High-function type		Standard type only	Standard type only
0	EASY	N.O.	OFF	OFF	Analog voltage output	P-1, Lo-1	Red when ON	Comparative output 1
1		N.C.	EASY	N.O.	Auto-reference	Hi-1		Comparative output 2
2	Hysteresis	N.O.		Hysteresis	N.C.	Remote zero-adjustment	P-2, Lo-2	Green when ON
3		N.C.	N.O.		—	Hi-2	Comparative output 2	
4	Window comparator	N.O.	Window comparator	N.C.	—	ADJ.	Always Red	Comparative output 1
5		N.C.		N.O.	—	—		Comparative output 2
6	—	—	—	N.C.	—	—	Always Green	Comparative output 1
7	—	—	—	—	—	—		Comparative output 2

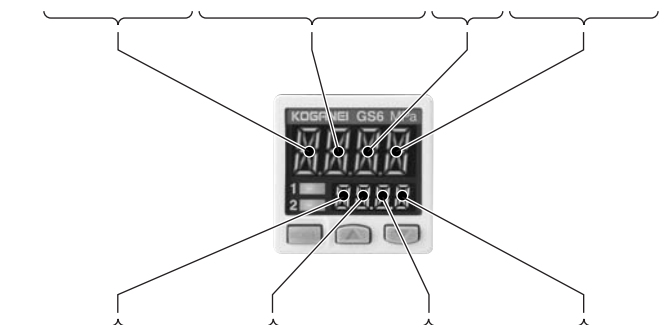

Code	Fifth digit	6th digit	7th digit	8th digit
	Response time	Unit selection	Display speed	Eco mode
0	2.5ms	MPa	250ms	OFF
1	5ms	kPa	500ms	Std
2	10ms	—	1000ms	Full
3	25ms	—	—	—
4	50ms	—	—	—
5	100ms	—	—	—
6	250ms	—	—	—
7	500ms	—	—	—
8	1000ms	—	—	—
9	5000ms	—	—	—

PRESSURE SWITCHES

## Order Codes

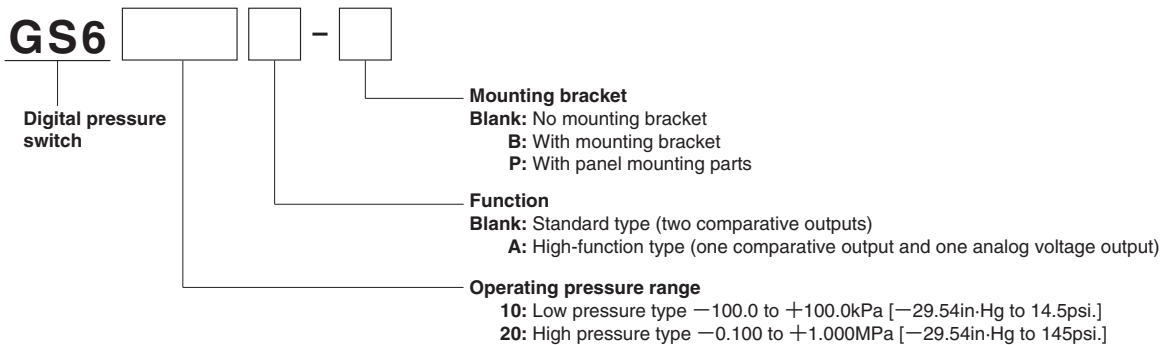

## Additional parts (to be ordered separately)

### Mounting bracket



### Panel mounting parts



**Dimensions mm [in.]**

**GS6** □ 0 □

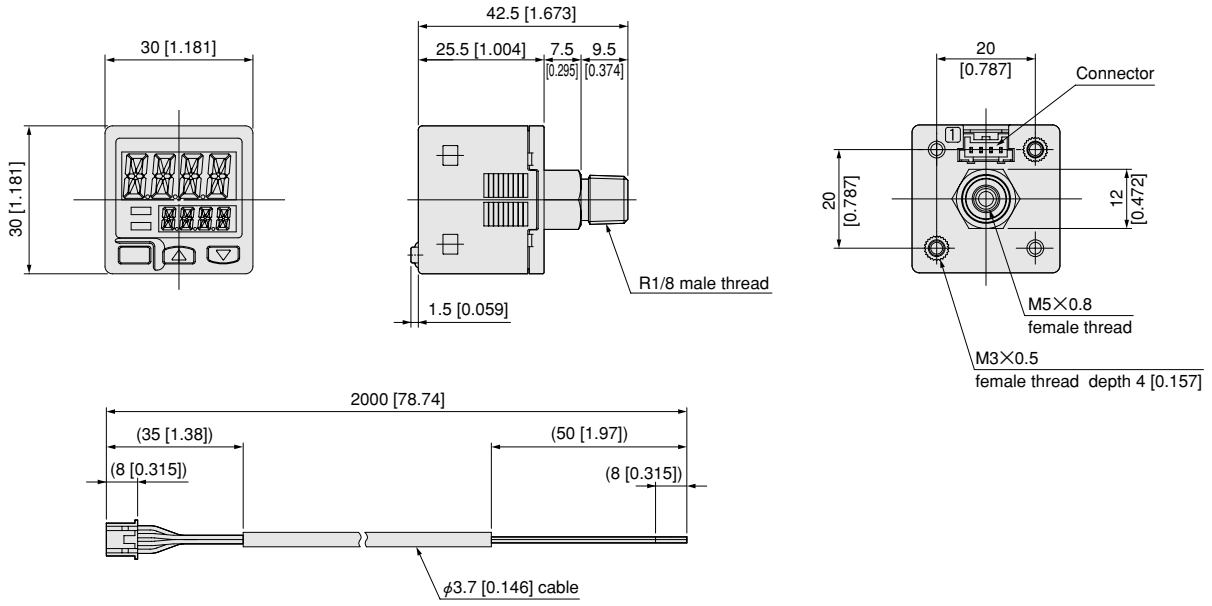

**GS6-B Mounting bracket (to be ordered separately)**

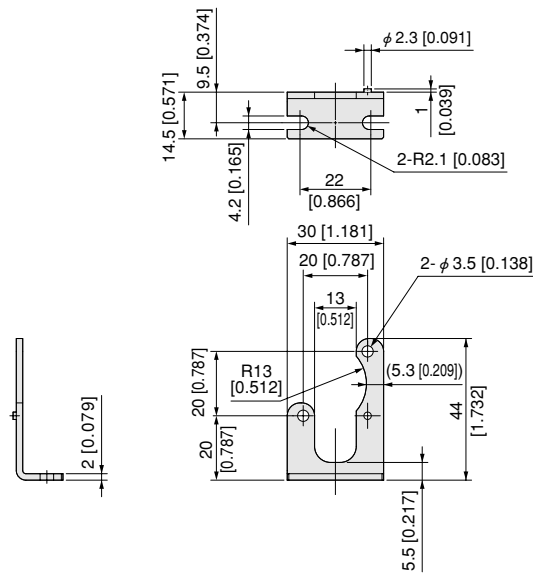

**Installation drawing**

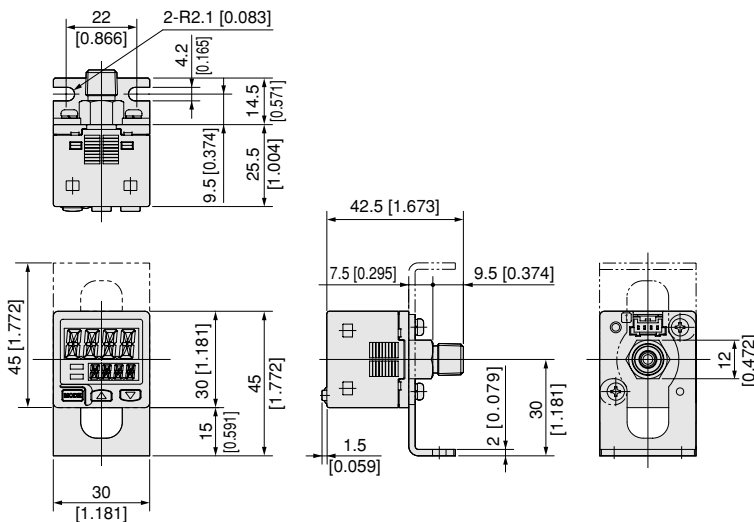

**GS6-P Panel mounting parts (to be ordered separately)**

**Installation drawing**

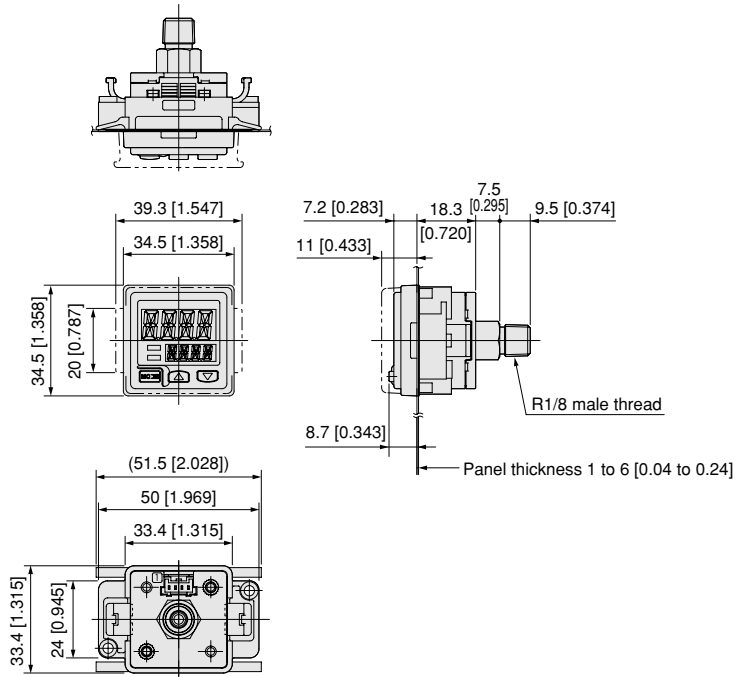

**Panel cut-out size**

**When mounting one unit**

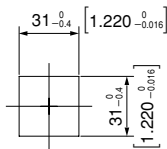

**When mounting N units in series in horizontal direction**

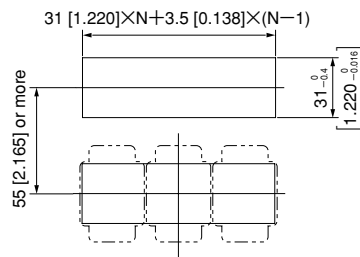

Note: Set the panel thickness to 1 to 6mm [0.04 to 0.24in.].

**When mounting N units in series in vertical direction**

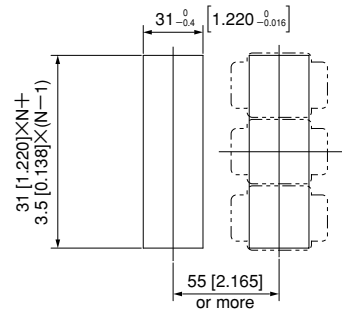

Note: Set the panel thickness to 1 to 6mm [0.04 to 0.24in.].