

SQUARE TYPE SOLENOID VACUUM VALVES

V100-F11 Series



Specifications

Basic model		V100E1-F11	MV100E1-F11-11	SV100E1-F11	MSV100E1-F11-11
Item					
Media		Vacuum		Vacuum and air	
Operation type		Direct acting			
Number of positions		2 positions			
Number of ports		2, 3 ports		3 ports	
Valve function		Normally closed (NC) or normally open (NO)	Normally open (NO)	Normally closed (NC) ^{Note 1}	Normally open (NO)
Effective area [Cv]	mm ²	5 [0.28]			
Port size		NPT1/8			
Lubrication		Not required			
Operating pressure range kPa {mmHg} [in.Hg]		-100~0 {-750.1~0} [-29.53~0]		-100~0 {-750.1~0} [-29.53~0], 0~0.9MPa {0~9.2kgf/cm ² } [0~131psi.]	
Proof pressure	MPa {kgf/cm ² } [psi.]	—		1.32 {13.5} [191]	
Response time ^{Note 2}	DC24V	20/20 or below			
	AC100V, AC200V	20/20 or below			
Maximum operating frequency	Hz	5			
Maximum temperature range (atmosphere and media)	°C [°F]	0~50 [32~122]			
Shock resistance m/s ² (G)	Lateral direction	1373.0 {140.0}			
	Axial direction	392.3 {40.0}			
Mounting direction		Any			
Mass	g [oz.]	190 [6.70]			

Notes: 1. The positive pressure side is normally closed.

2. For V100E1, values when the vacuum is -100kPa {-750.1mmHg} [-29.53in.Hg]. For SV100E1, values when the air pressure is 0.5MPa {5.1kgf/cm²} [73psi.].

Exhaust time

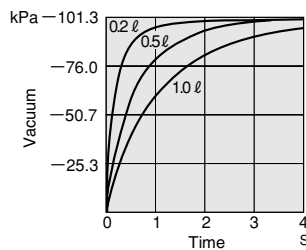

Air supply time

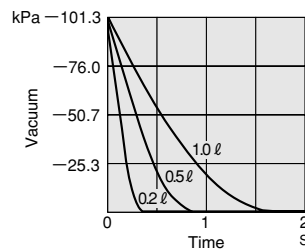

1kPa = 0.145psi.

Solenoid Specifications

Rated voltage ^{Note 4}		DC24V	AC100V		AC200V	
Item						
Type		DC type	Flywheel type			
Operating voltage range	V	21.6~26.4 (24±10%)	90~110 (100±10%)		180~220 (200±10%)	
Current ^{Note 1} (when rated voltage is applied)	Frequency	—	50	60	50	60
	Energizing ^{Note 2} mA (r.m.s.)	270 (6.5W) [282 (6.8W)]	100 [107]	95 [101]	41 [45]	39 [42]
Allowable leakage current	mA	20	10		5	
Insulation resistance	MΩ	10				
Wiring type and lead wire length	Standard	Grommet type: 300mm [11.8in.]				
	Optional	With DIN connector				
Color of lead wire		Red {Red (+), Blue (-)} ^{Note 1} Red (+), Black (-) ^{Note 3}	Yellow, Black		White, Black	
Color of LED indicator (optional)		Red	Yellow		Green	
Surge suppression	Standard	—				
	Optional	Flywheel diode		Flywheel diode		

Notes: 1. Figures and descriptions in brackets [] are for solenoids with LED indicators.

2. Since the AC types have built-in flywheel diodes, the starting current value and energizing current value are virtually the same.

3. For solenoids with surge suppression, and solenoids with LED indicators and surge suppression.

4. DC12V, AC120V coil are available for standard.

Operating Principles and Symbols

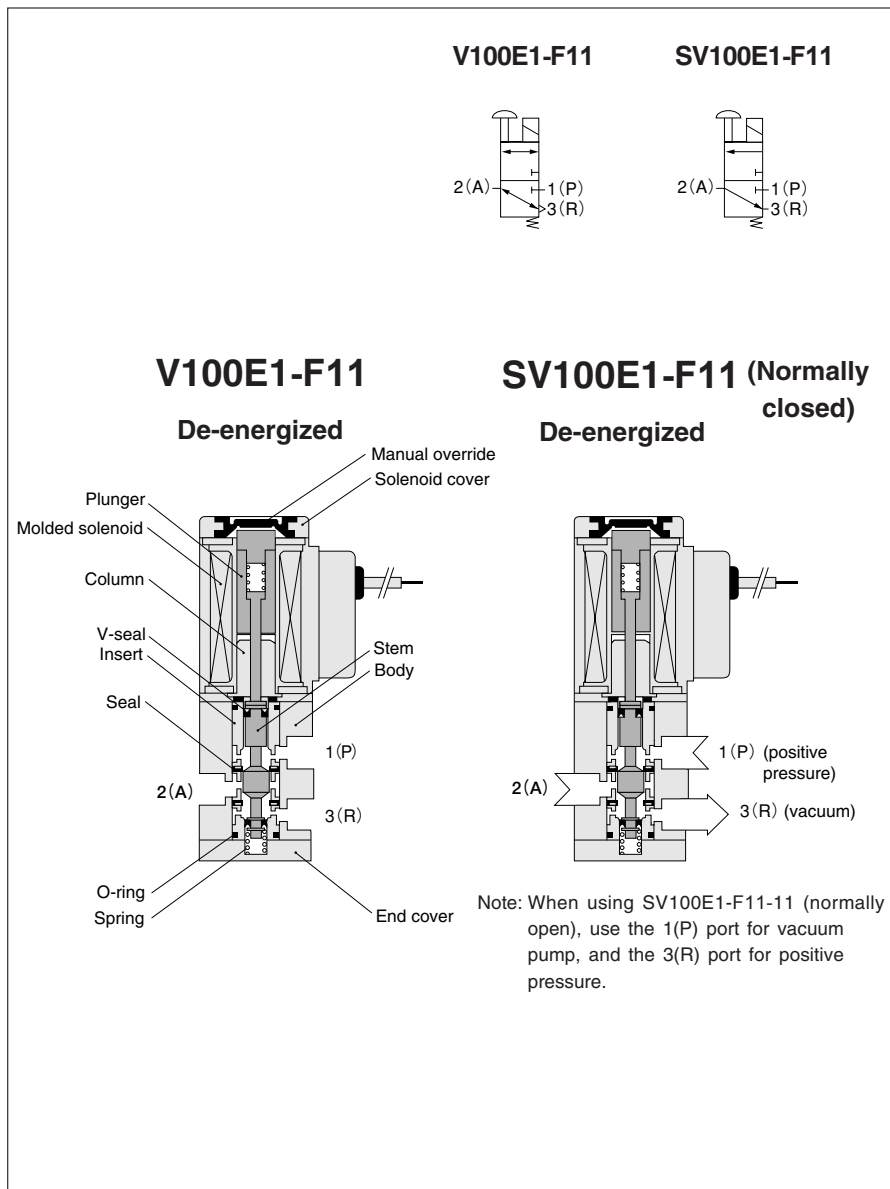

Valve functions and connection port configurations

V100-F11

When not using positive pressure

		De-energized		Energized
2-port	Normally closed (NC)	2(A) → 1(P) (vacuum pump, etc.)	3(R) (plug)	→
	Normally open (NO)	2(A) → 3(R) (vacuum pump, etc.)	1(P) (plug)	→
3-port	Normally closed (NC)	2(A) → 1(P) (vacuum pump, etc.)	3(R) (atmosphere)	→
	Normally open (NO)	2(A) → 3(R) (vacuum pump, etc.)	1(P) (atmosphere)	→
Selector valve		2(A) → 1(P) (vacuum pump, etc.)	3(R) (vacuum pump, etc.)	→
Divider valve		(vacuum pump, etc.) 2(A) → 1(P)	3(R)	→

SV100-F11

When using both vacuum and positive pressure

3-port	Normally closed (NC)	2(A) → 1(P) (positive pressure)	3(R) (vacuum pump, etc.)	→
	Normally open (NO)	2(A) → 3(R) (vacuum pump, etc.)	1(P) (positive pressure)	→

Major Parts and Materials

	Parts	Materials
Valve	Body	Aluminum alloy (anodized)
	Stem	
	Seal	
	Insert	
	Spring	
	Mounting base	
	Plunger	
Manifold	Column	Magnetic steel (zinc plated)
	Body	Aluminum alloy (anodized)
	Block-off plate	Mild steel (zinc plated)
	Seal	Synthetic rubber
	Mounting bracket	Mild steel (zinc plated)

Remark: Materials that generate copper ions are not used for the non-ion specification.

Manifold Connection Port Size

Manifold model	Port	Location of piping connection	Port size
HM□T-F11	1(P)	Manifold	NPT1/8
	2(A)	Valve	
	3(R)	Manifold	
HM□U-F11	1(P)	Manifold	NPT1/8
	2(A)	Valve	
	3(R)	Valve	
HM□L-F11	1(P)	Manifold	NPT1/8
	2(A)	Valve	
	3(R)	Valve	

Manifold Mass

Manifold model	Mass calculation of each unit (n=number of units)	Block-off plate
HM□T-F11	(73×n)+73 [(2.57×n)+2.57]	21 [0.74]
HM□U-F11	(26×n)+130 [(0.92×n)+4.59]	11 [0.39]
HM□L-F11	(26×n)+130 [(0.92×n)+4.59]	11 [0.39]

g [oz.]

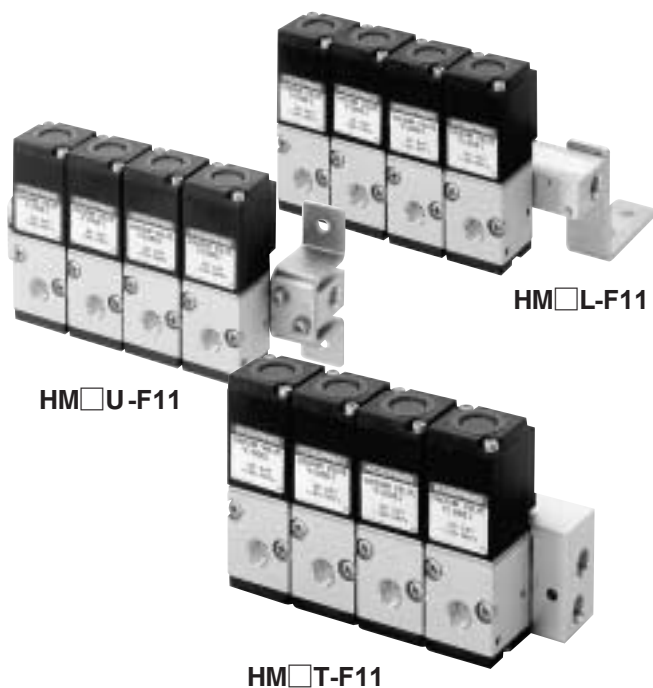

SQUARE TYPE SOLENOID VACUUM VALVES

Optional System

Single unit

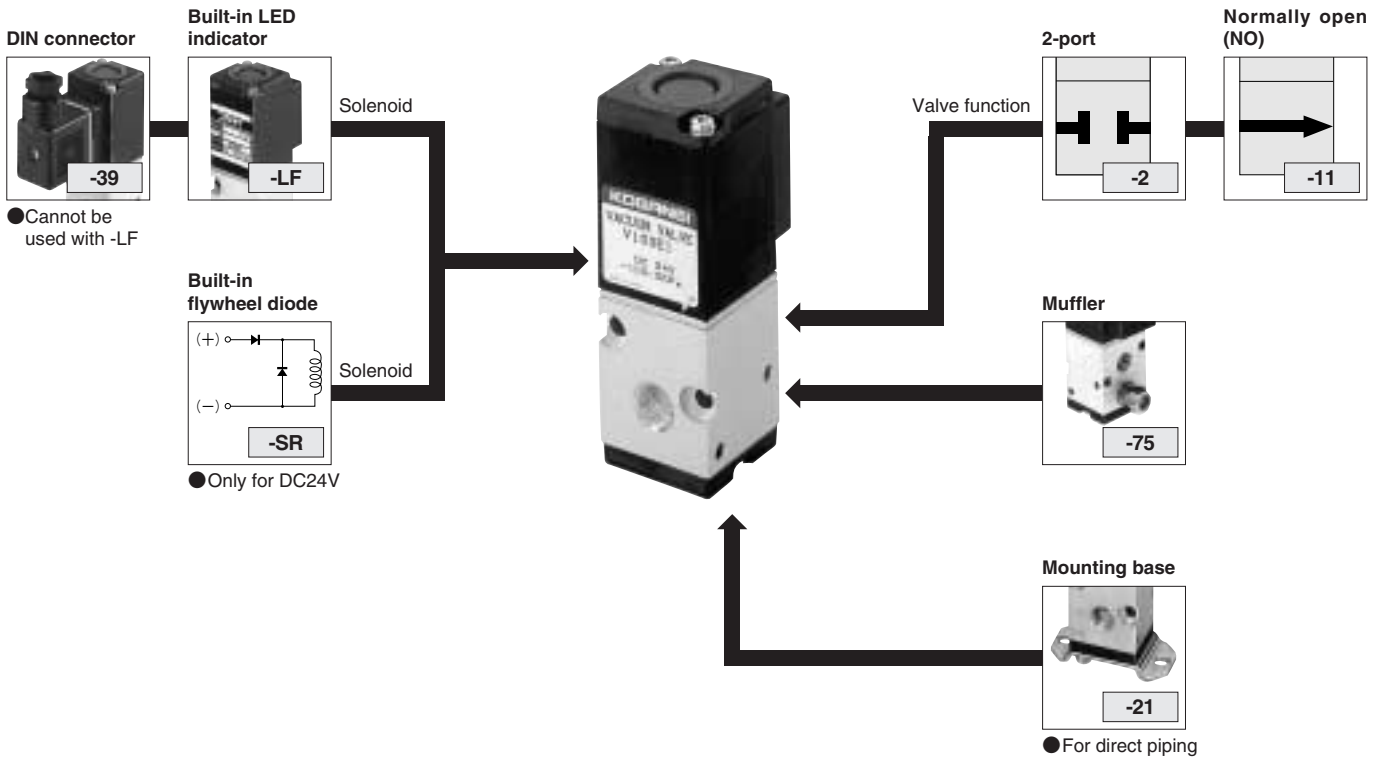

Solenoid Vacuum Valve Order Codes

For vacuum

	Basic model	Valve function		Mounting base	Option				Voltage
		2-port	2-port Normally open (NO)		DIN connector	Muffler	LED indicator	Flywheel diode	
Direct piping	3-port shared with normally open and closed	V100E1-F11	-2 ^{Note 2}	-21	-39	-75	-LF	-SR	DC12V DC24V AC100V AC200V
	2-port normally closed		-2 ^{Note 2}			-11			
For manifold only ^{Note 1}	3-port normally open	MV100E1-F11	-2	-11	-39	-75 ^{Note 3}	-LF	-SR	DC12V DC24V AC100V AC200V
	2-port normally open		-2			-11			

- Notes: 1. They cannot be used as single units.
2. Plug included.
3. Selection available only for U or L type manifolds.

● Always make a selection.

● For DC12V, DC24V only. Standard for AC100V and AC200V.

● Not available for DIN connector

For both vacuum and positive pressure

	Basic model	Valve function		Mounting base	DIN connector	LED indicator	Flywheel diode	Voltage
		Normally open (NO)						
Direct piping	3-port ^{Note 1} normally closed	SV100E1-F11	-11	-21	-39	-LF	-SR	DC12V DC24V AC100V AC200V
	3-port normally open							
For manifold only ^{Note 2}	3-port normally open	MSV100E1-F11	-11		-39	-LF	-SR	DC12V DC24V AC100V AC200V

- Notes: 1. The positive pressure side is normally closed.
2. They cannot be used as single units.

● Always make a selection.

● For DC12V, DC24V only. Standard for AC100V and AC200V.

● Not available for DIN connector

Optional System

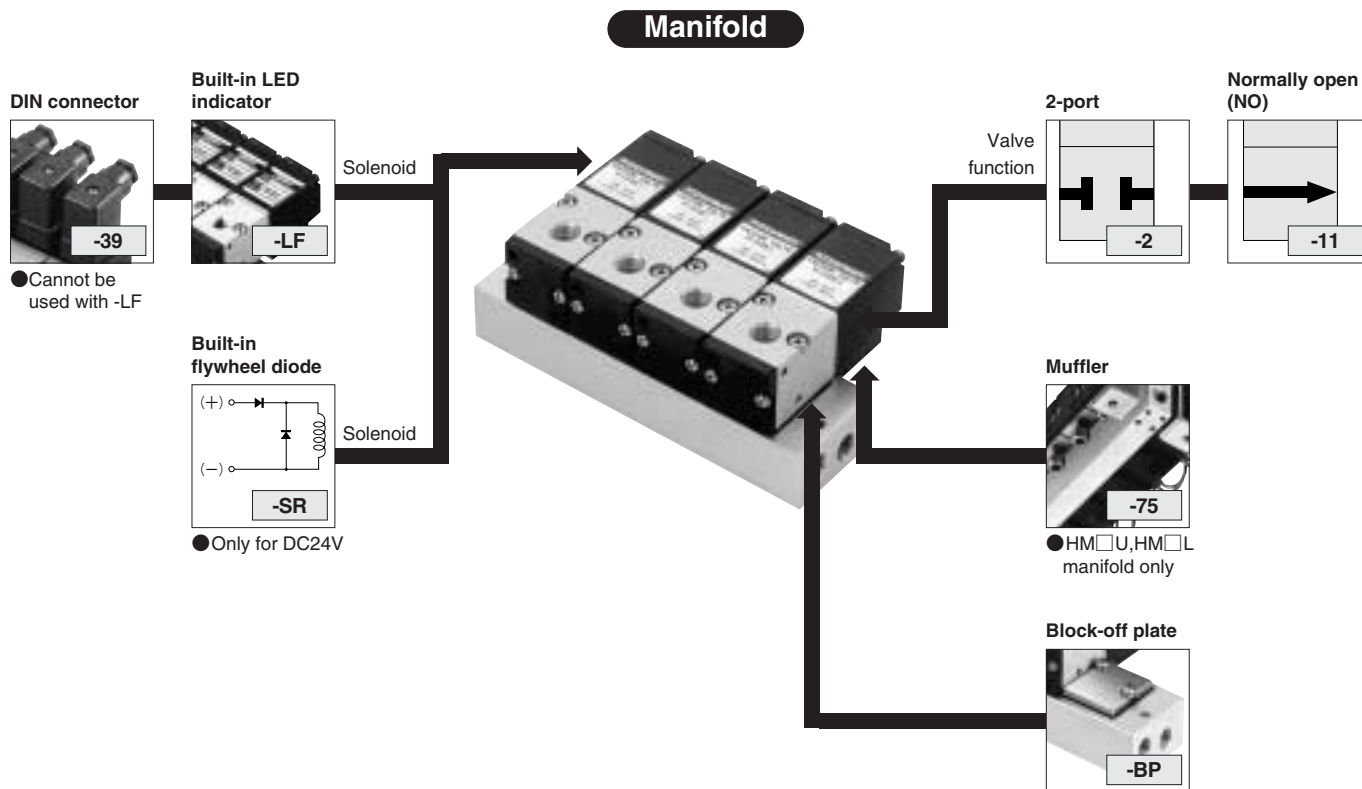

Manifold Order Codes

For vacuum

Manifold model	Station	Valve model	Option									
			Number of units	Basic model	2-port	Normally open (NO)	DIN connector	Muffler	LED indicator	Flywheel diode	Voltage	
HM	2 ⋮ 10	T-F11	stn. <input type="checkbox"/>	V100E1-F11	-2			-39		-LF	-SR	DC12V DC24V AC100V AC200V
		MV100E1-F11	stn. <input type="checkbox"/>		-2	-11						
	U-F11	stn. <input type="checkbox"/>	V100E1-F11	-2			-39	-75		-LF	-SR	DC12V DC24V AC100V AC200V
	L-F11	stn. <input type="checkbox"/>	MV100E1-F11	-2	-11			-75				

- Valve mounting location from the left-hand side when facing the 2(A) port
- Always make a selection.
- Specify the valve model for each station.
- Enter -BP when closing a station with a block-off plate without mounting a valve.
- For DC12V, DC24V only. Standard for AC100V and AC200V.
- Not available for DIN connector

For both vacuum and positive pressure

Manifold model	Station	Valve model	Option				Voltage		
			Number of units	Basic model	Normally open (NO)	DIN connector		LED indicator	Flywheel diode
HM	2 ⋮ 10	T-F11	stn. <input type="checkbox"/>	SV100E1-F11 ^{Note}		-39	-LF	-SR	DC12V DC24V AC100V AC200V
		MV100E1-F11	stn. <input type="checkbox"/>		-11				

- Note: The positive pressure side is normally closed.
- Valve mounting location from the left-hand side when facing the 2(A) port
 - Always make a selection.
 - Specify the valve model for each station.
 - Enter -BP when closing a station with a block-off plate without mounting a valve.
 - For DC24V only. Standard for AC100V and AC200V.
 - Not available for DIN connector

SQUARE TYPE SOLENOID VACUUM VALVES

Dimensions (mm)

V100E1-F11 SV100E1-F11

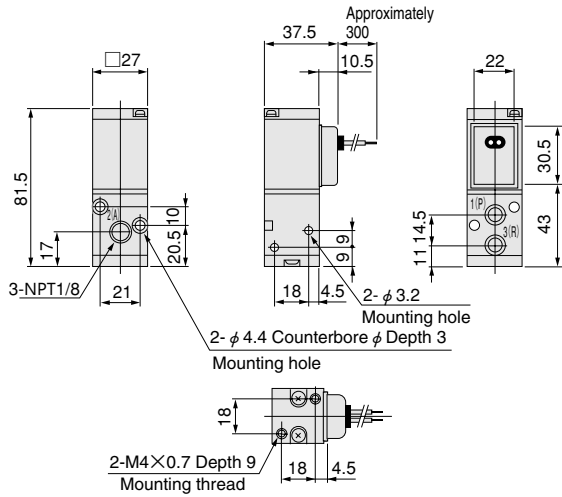

HM□T-F11

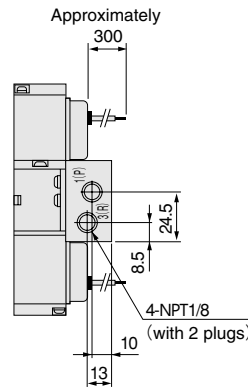
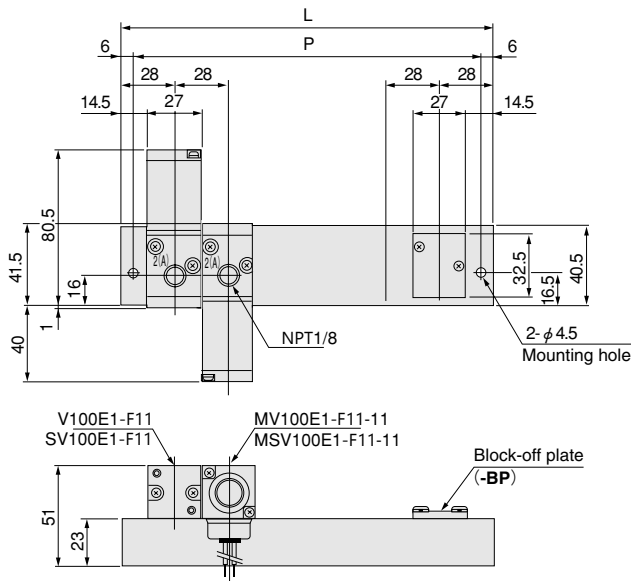

Unit dimensions

Model	L	P
HM2T	84	72
3T	112	100
4T	140	128
5T	168	156
6T	196	184
7T	224	212
8T	252	240
9T	280	268
10T	308	296

Options

● Mounting base: -21

● Solenoid with DIN connector: -39

● Solenoid with LED indicator: -LF

● Muffler: -75

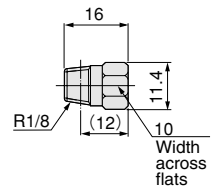
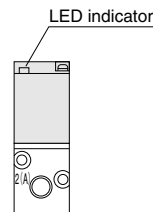
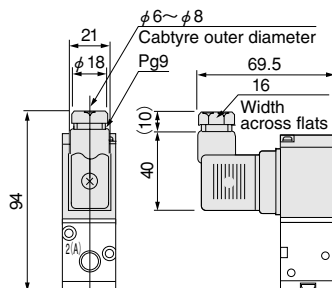
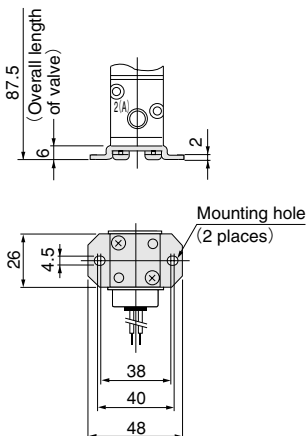

Dimensions (mm)

HM□U-F11

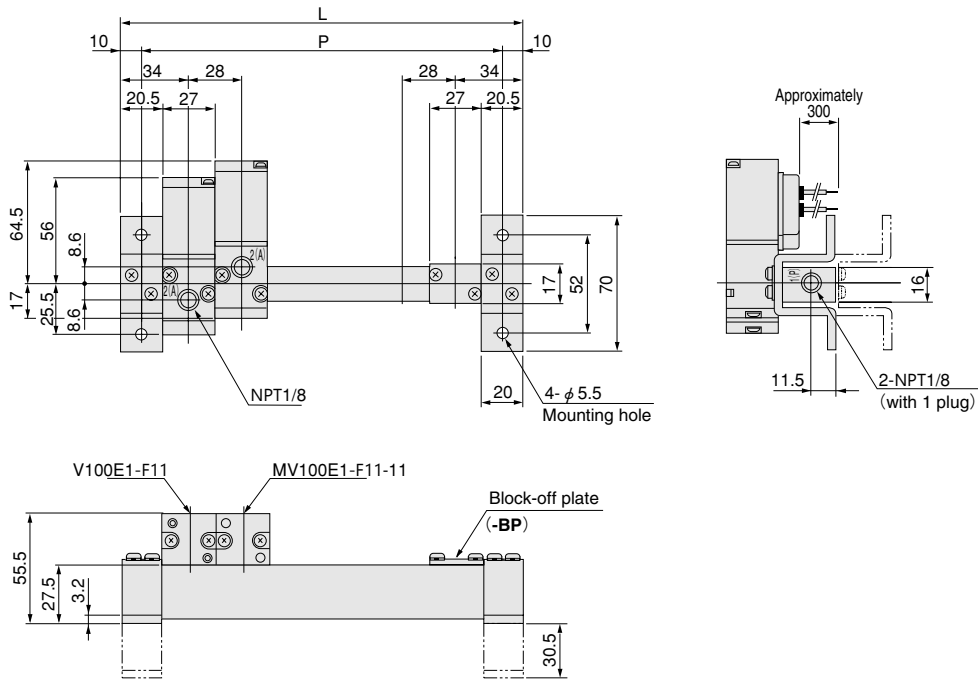

Unit dimensions

Model	L	P
HM2U	96	76
3U	124	104
4U	152	132
5U	180	160
6U	208	188
7U	236	216
8U	264	244
9U	292	272
10U	320	300

HM□L-F11

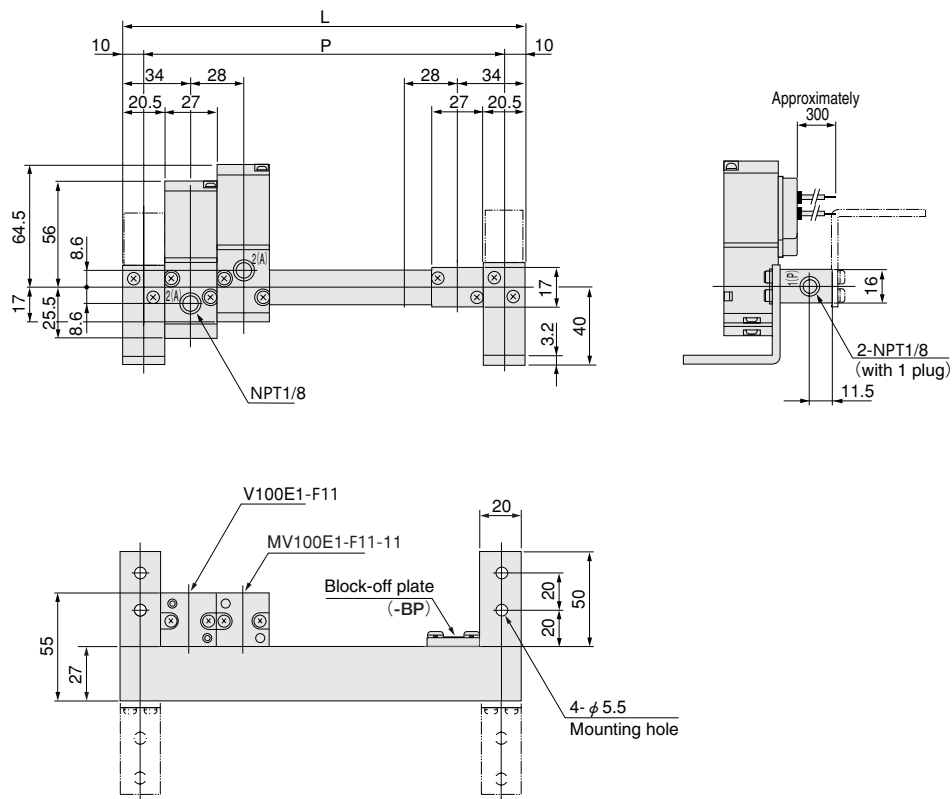

Unit dimensions

Model	L	P
HM2L	96	76
3L	124	104
4L	152	132
5L	180	160
6L	208	188
7L	236	216
8L	264	244
9L	292	272
10L	320	300



Solenoid

Internal circuit

●DC24V

Standard solenoid

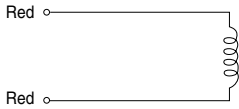

Solenoid with LED indicator

Order code: -LF,-L

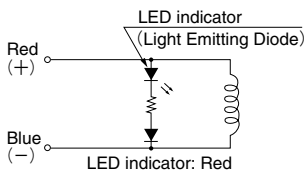

Solenoid with surge suppression

Order code: -SR

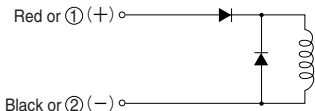

① and ② are for with DIN connector (Order code: -39).

Solenoid with LED indicator and surge suppression

Order code: -LF-SR

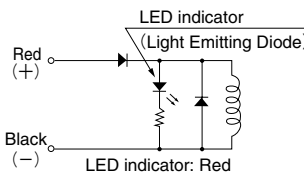

●100V, AC200V

(Surge suppression)

Standard solenoid

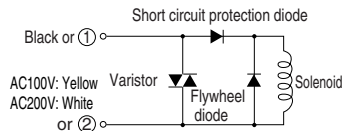

① and ② are for with DIN connector (Order code: -39).

Solenoid with LED indicator

Order code: -LF,-L

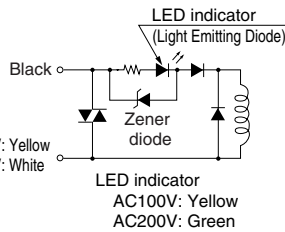

- Cautions:**
1. Do not apply megger between the lead wires.
 2. The DC24V solenoid will not short circuit even if the wrong polarity is applied, but the valve with surge-suppression will not operate. Also, the LED indicator will not turn on, for units with LED indicators.
 3. Leakage current inside the circuit could result in failure of the solenoid valve to return, or in other erratic operation. Always use within the range of the allowable leakage current. When circuit conditions, etc. cause the leakage current to exceed the allowable leakage current, consult us.
 4. Since the AC solenoid uses a diode for the solenoid, always connect lead wires of the same color when wiring a number of solenoid valves in parallel. The DC24V standard solenoid, however, has no polarity, so any lead wire connection is acceptable.

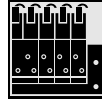

Manifold

Piping

The 1(P) port and 3(R) port are located at both end surfaces of the manifold, and the mounting location determines selection of piping direction.

At shipping, ports on one side are plugged. Remove them, and then use sealing tape or other sealing agent, and then tighten.

Block-off plate

To close the unused stations, use a block-off plate (Order code: -BP).

- Cautions:**
1. For the 1(P) port piping, use a size that matches the manifold's piping connection port.
 2. When installing piping or mufflers to the 3(R) port, ensure there will be minimum exhaust resistance.
 3. When multiple number of valves are operated simultaneously on a multi-units manifold, or when used at high frequency, use the 1(P) and 3(R) ports on both end surfaces.



General precautions

Mounting

1. While any mounting direction is acceptable, for installation using the mounting base (Order Code: -21), make sure to avoid applying strong shocks in the lateral direction.
2. When using in locations subject to dripping water or oil, or in extremely dusty locations, use a cover, etc. to protect the unit. In addition, install a muffler, etc. to the exhaust port to prevent dust from entering the unit.
3. Before piping with valves, always thoroughly blow off foreign materials (blow by compressed air) in the piping interior. Entering machining chips or sealing tape, rust, etc., generated during plumbing could result in air leaks and other defective operations.
4. When mounting a valve unit inside the control panels or when the operation requires long energizing periods, provide heat radiation measures.

Piping

In the SV100 series, the flow direction is limited. See p.864 for the valve functions and piping port configurations, then make the piping.

Media

1. Use air for the media. For use of any other media, consult us.
2. Air used for the valve should be clean air that contains no deteriorated compressor oil, etc. Install an air filter (filtration of 40µm or less) near the valve to remove collected liquid or dust. In addition, drain the air filter periodically.

Lubrication

While the unit can be used without lubrication, the Turbine Oil Class 1 (ISO VG32) or equivalent is recommended when using dry air (air that contains no moisture or oil content). Avoid using spindle oil or machine oil.

Atmosphere

Cannot be used when the substances listed below are found in the media and atmosphere. Organic solvents, phosphate ester type hydraulic oil, sulphur dioxide, chlorine gas, or other acids, etc.