



FUJIKURA COMPOSITES

SUPER PRECISION AIR REGULATOR

RS SERIES

SUPER PRECISION AIR REGULATORS

RR SERIES

SUPER PRECISION AIR RELAYS

- ▶ Air Pressure Regulators that attain the ultimate in pressure control.



RS / RR

**SUPER PRECISION
AIR REGULATORS**

**SUPER PRECISION
AIR RELAYS**

DESCRIPTION

Servo-balanced system comprising Rolling diaphragm and Measuring capsule provides exceptionally precise and stable pressure control with constant bleed feature. Series-RR offers exceptionally precise 1:1 pressure relay control with \pm bias adjustment capability by external pilot operation.



RS



RR

FEATURES

- **Ultra Accurate and Stable Pressure Regulation :**
Sensitivity $\leq 0.1\%$ F.S. Repeatability $\leq \pm 0.1\%$ F.S.
- **Extremely Excellent Characteristics :** in Relief-, Pressure-, and Flow- sensitivities. Particularly, minimum relief pressure as low as 3×10^{-5} MPa (theoretical Relief sensitivity) finds best applications in Web tension controls and Air balancers, etc.
- **Excellent Start-up Stability :**
No readjustment of regulated pressure required even after long "down - time".
- **Remote Control of Pressure :** (Series-RR)
Advisably used for high precision remote control of pressure.
- **Adaptable Mounting :**
Mounts at any angle. Bracket, Panel or Pipe mounted.

SPECIFICATIONS

| TERM | TYPE | INTERNAL PILOT | RS-4 | RS-8 | RS · HR-8 |
|---------------------------------|--------------|----------------|------------------------------------------------------|----------|-----------|
| | | EXTERNAL PILOT | — | RR-8 | RR · HR-8 |
| Working Fluid | | — | Clean Compressed Air | | |
| Set Pressure Range | kPa | | 14 ~ 420 | 14 ~ 840 | |
| Supply Pressure Range | kPa | | 990 | | |
| ※ 1 Input Signal Pressure Range | kPa | | — | 14 ~ 840 | |
| Relief Function | | — | Incorporated | | |
| ※ 2 Repeatability | % F.S. | | Within $\pm 0.1\%$ | | |
| ※ 2 Pressure Sensitivity | % F.S. | | Within 0.1% | | |
| Relief Sensitivity | kPa | | 0.03 (Theoretical) | | |
| ※ 3 Relief Flow Rate | /min(normal) | | 130 | 260 | |
| ※ 4 Air Consumption | /min(normal) | | Within 3.7 | | |
| Operating Temperature | °C | | 5 ~ 60 | | |
| Pipe Port | Rc | | RS = 1/8, 1/4, 3/8 ; RR = 1/4, 3/8 | | |
| Gauge Port | Rc | | 1/4 (Two Ports) | | |
| Accessory Parts | | | Mounting Bracket (Standard) | | |
| Weight | kg | | RS = 0.75, RR (std.) = 0.72, RR (W.Bias knob) = 0.78 | | |

OPTION

(1) Bias Adjusting Knob BA (Series RR)

Turning of BA knob effects bias pressure within the range of ± 0.2 MPa

(2) Pressure Gauge G :

- Accuracy $\pm 1.5\%$ F.S.

| OPT.No. | Unit | Pressure Range | Min. Graduation |
|---------|------|----------------|-----------------|
| G025 | MPa | 0 ~ 0.25 | 0.005 |
| G060 | MPa | 0 ~ 0.6 | 0.01 |
| G100 | MPa | 0 ~ 1 | 0.02 |

Note : ※ 1 Applicable to Series-RR only.

※ 2 F.S. = Full Scale.

※ 3 At Set pressure 0.2MPa

※ 4 Because of air bleed servo control action, a small amount of air escapes normally into atmosphere.

MODEL DESIGNATION

Example RS · HR — 8 — 2 — OPTION (1) — OPTION (2)

| Series Code | |
|-------------|----------------|
| RS | Internal Pilot |
| RR | External Pilot |

| Set Pressure Range | |
|--------------------|--------------|
| 4 | 14 ~ 420 kPa |
| 8 | 14 ~ 840 kPa |

| Bias Adjusting Knob | |
|---------------------|---------------------|
| None | Standard |
| BA | Bias Adjusting Knob |

| Pressure Gauge | |
|----------------|--------------|
| None | Standard |
| G025 | 0 ~ 0.25 MPa |
| G060 | 0 ~ 0.6 MPa |
| G100 | 0 ~ 1 MPa |

| Relief Capacity | |
|-----------------|-------------|
| None | Standard |
| HR | High Relief |

| Pipe Port Size | |
|----------------|--------|
| 1 | Rc 1/8 |
| 2 | Rc 1/4 |
| 3 | Rc 3/8 |

TYPICAL CHARACTERISTIC CURVES & ADJUSTMENT

Pressure Characteristic

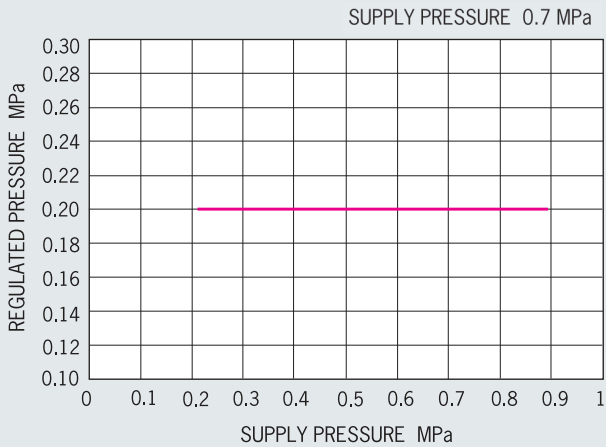

Flow Characteristic

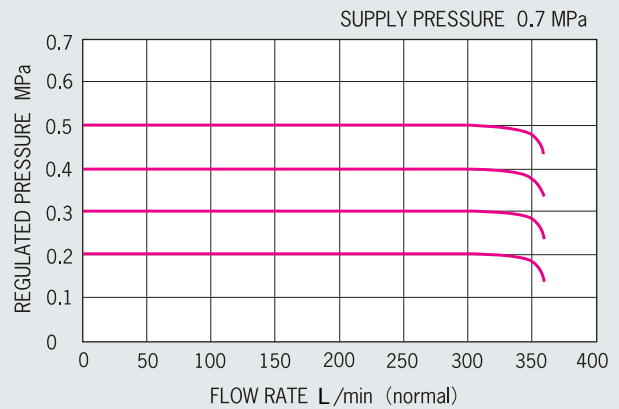

RS-8, RR-8

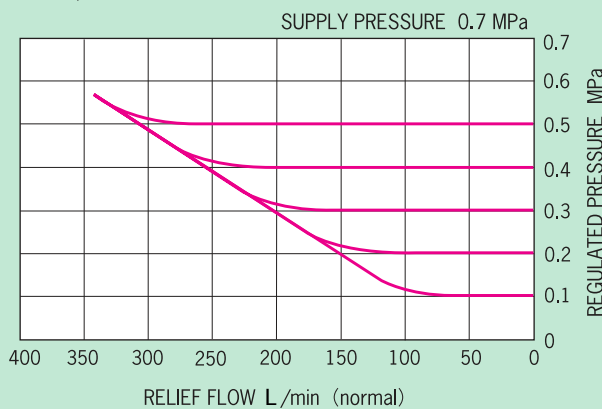

RS · HR-8, RR · HR-8

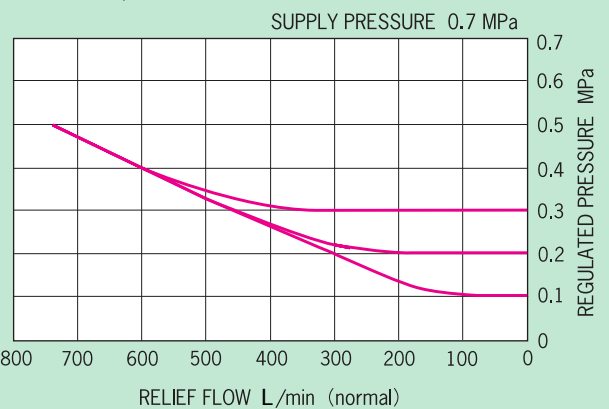

BIAS PRESSURE ADJUSTMENT PROCEDURE (Series-RR)

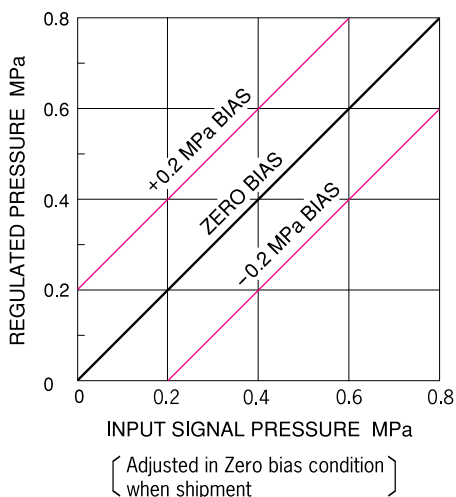

- ① First apply pressure to primary port. After that, input signal pressure.
 - ◆ The reverse order may cause failure of capsule.
- ② Depress fully Bias knob and turn it to engage the slit of Capsule screw.
- ③ Turn Bias knob clockwise / counter clockwise to increase / decrease bias pressure (up to +0.2MPa / -0.2MPa).
 - ◆ Exceeding these limits may cause failure of Capsule.

Note : Series-RR does not regulate below 14kPa output pressure, as a minimum output pressure is necessary to provide bleed air to Pilot pressure chamber.

JIS SYMBOL

Series-RS (Internal Pilot)

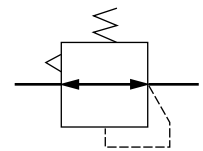

Series-RR (External Pilot)

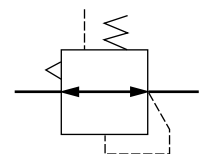

OUTSIDE DIMENSIONS

RS SERIES

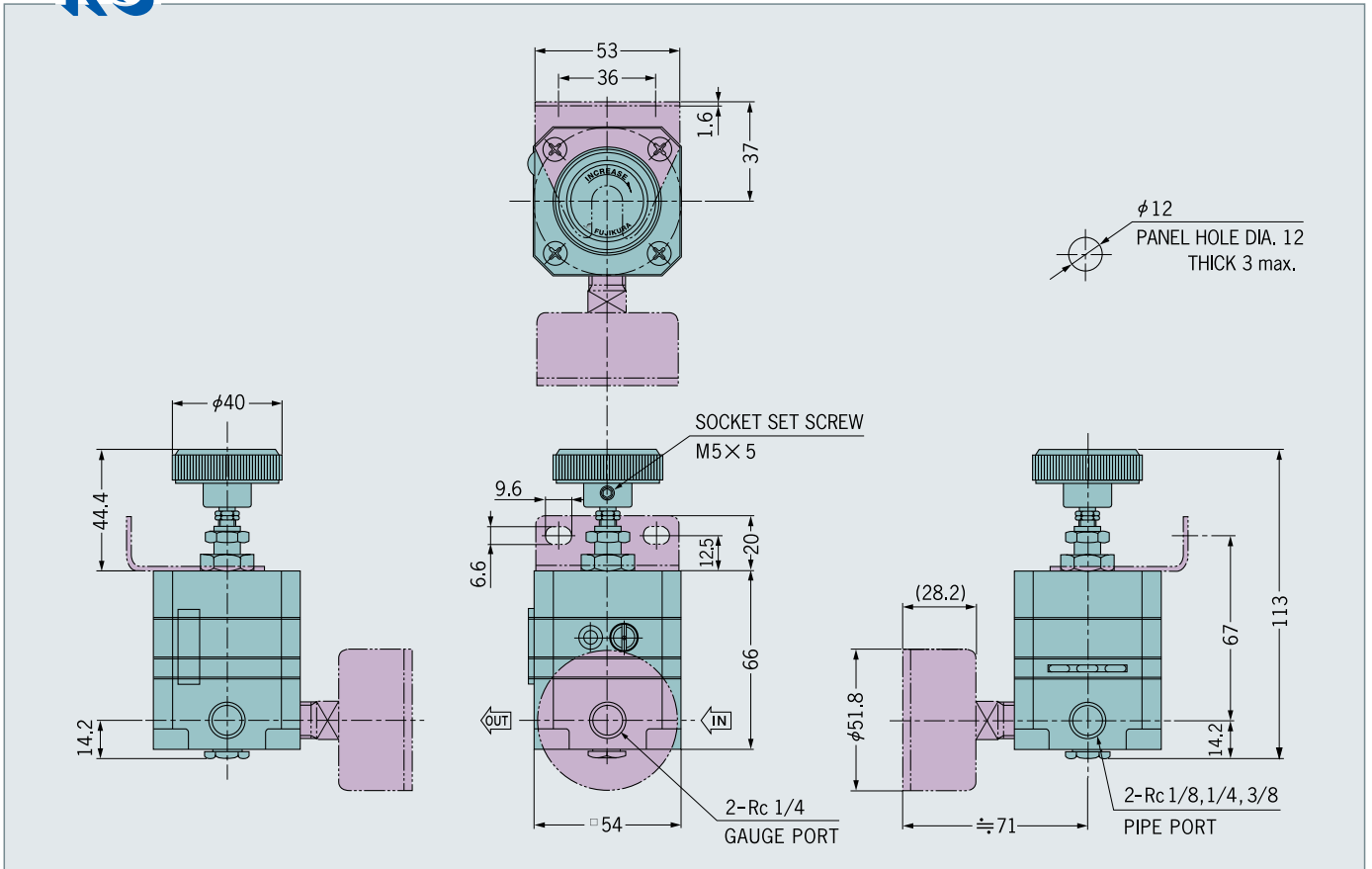

EXPLANATORY CONSTRUCTION AND PRINCIPLE OF OPERATION

Series-RS and Series-RR have the same construction and perform pressure control with the same operating principle, except that Series-RR can control output pressure with a pilot signal pressure externally applied.

Series-RS (Internal Pilot)

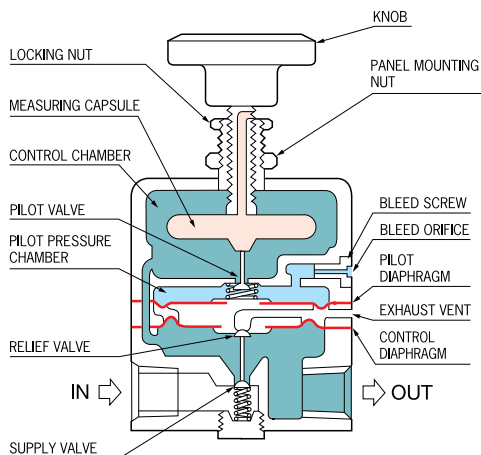

Series-RR (External Pilot)

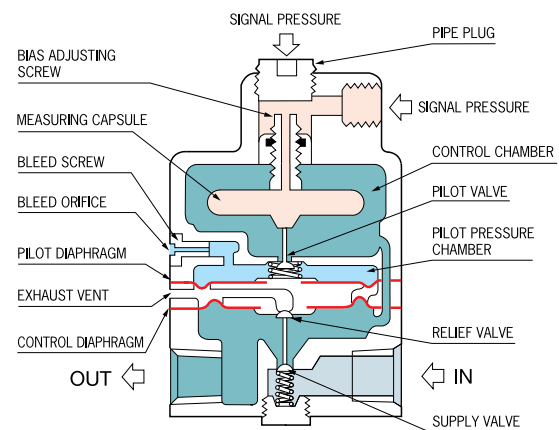

PRINCIPLE OF OPERATION (COMMON TO RS AND RR)

- Series-RS and -RR utilize a servo balanced system in which Supply -and Relief -valves are operated by a pilot valve. The pilot valve is opened or closed by expansion or contraction of a sensitive Measuring capsule.
- The regulated pressure is conducted into Control chamber and surrounds Capsule, the "heart" of the regulator. Measuring capsule offers extreme stability of movement under all operating conditions.
- A small amount of air flows normally through Pilot valve into Pilot pressure chamber and out through Bleed orifice to atmosphere, assuring the stable pilot pressure.
- A small change in output pressure will cause Capsule to flex slightly and thus move Pilot valve, resulting in a substantial change in the Pilot pressure.
- In turn, this change upsets the force balance of Diaphragm assembly, which causes an appropriate movement of either Supply or Relief valve, thus correcting

any small error in output pressure. Eventually, Capsule and Pilot valve return to their initial equilibrium positions respectively.

- The primary reason for the ultra high accuracy is the fact that the movement of Pilot valve, required to effect substantial changes in Supply valve position is extremely small. The high gain of this servomechanism permits desired output pressure to be maintained with exceptional accuracy and repeatability.
- Manual adjustment of Control knob provides sensitive setting of output pressure (Series-RS) or bias pressure (Series-RR).

RELAY FUNCTION (FOR SERIES-RR ONLY)

A change in Signal pressure to cause similar flexure of Measuring capsule requires an exactly equal change in output pressure to return Capsule and Pilot valve to their equilibrium position. This gives Series-RR its precise 1 : 1 ratio pressure relay control characteristic with bias adjustment capability by external pilot operation.

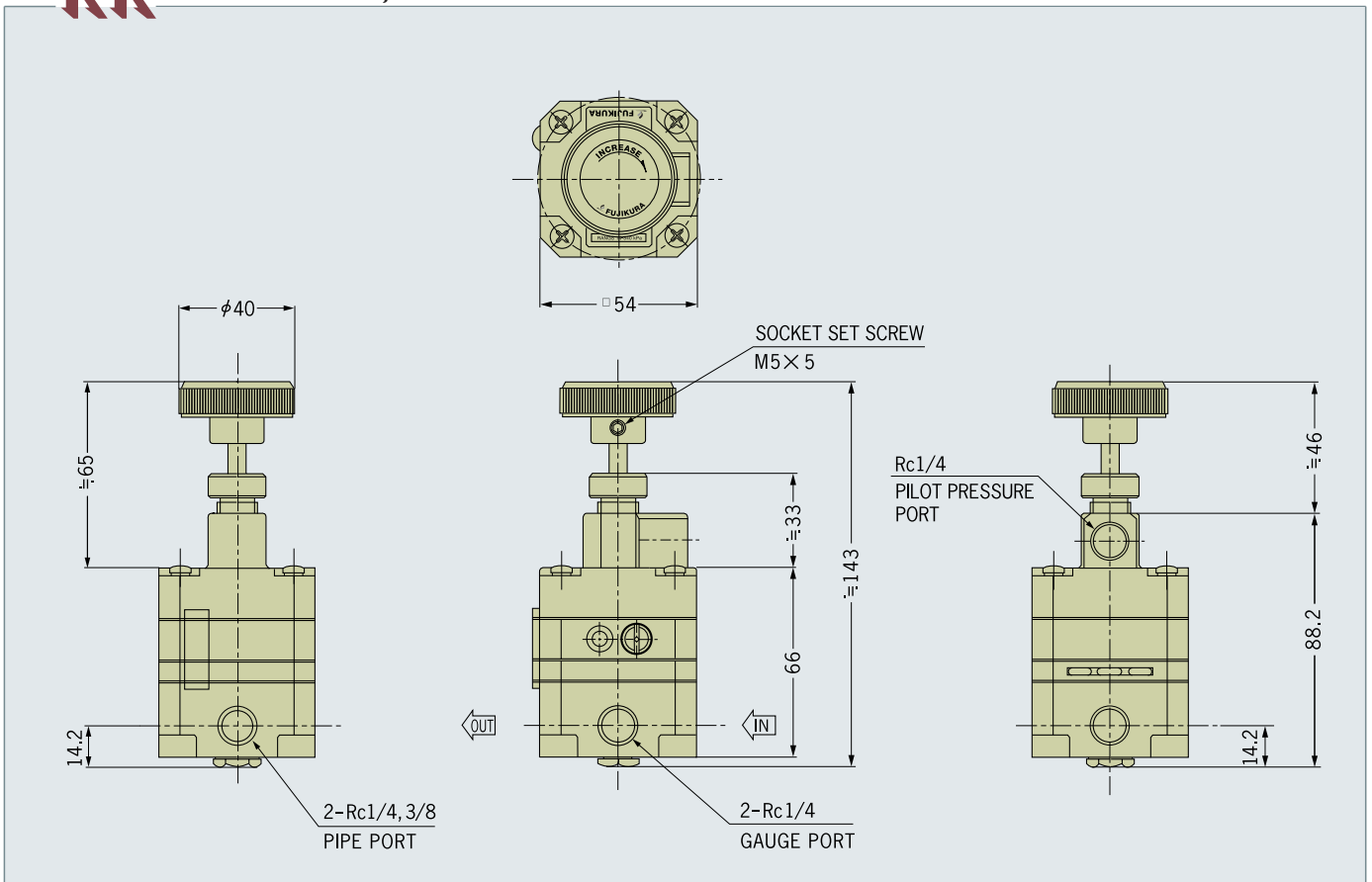
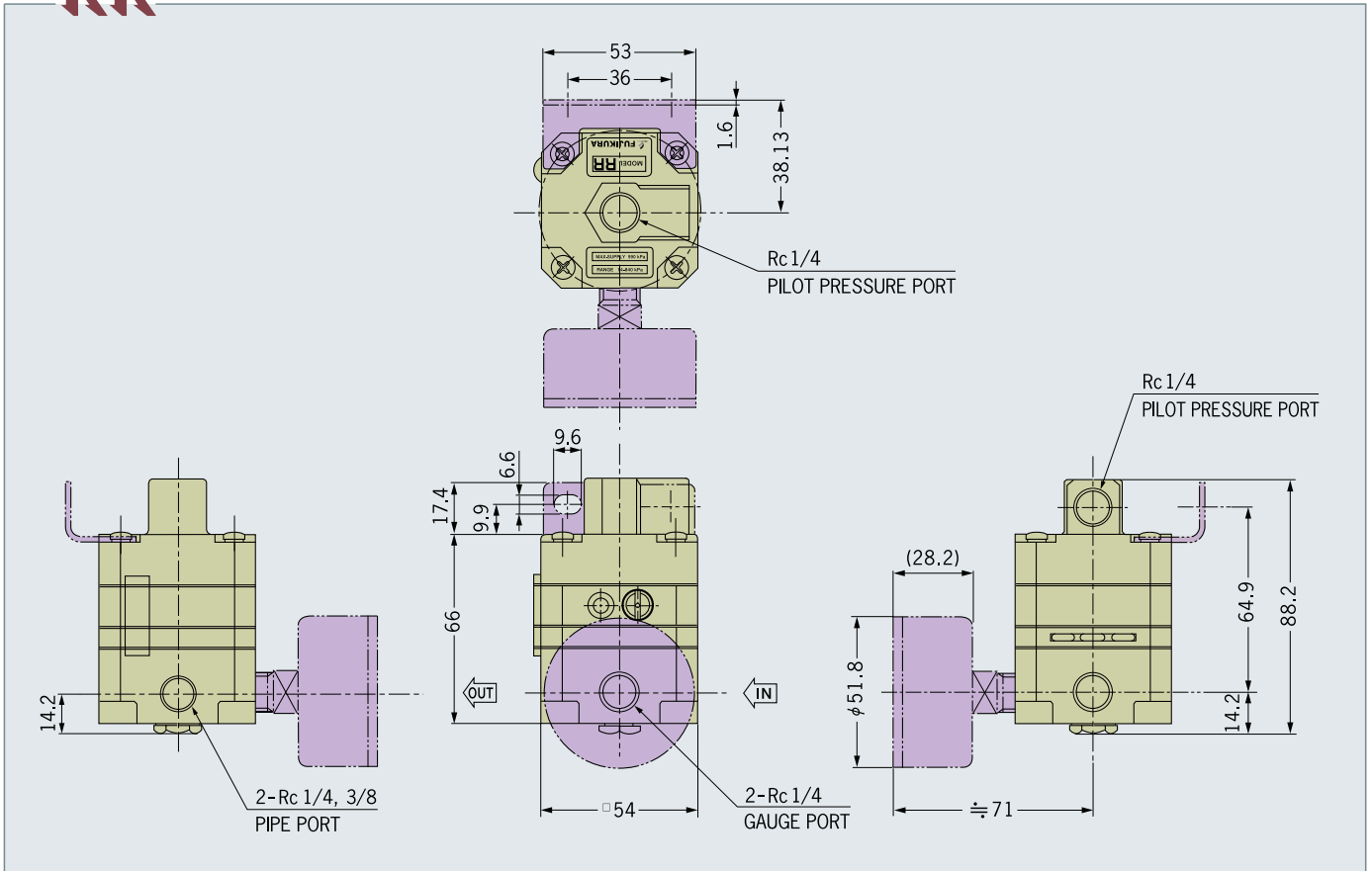

FUJIKURA'S Super Precision Air Regulators and Air Relays (Series-RS and Series-RR) are widely used in precision control applications such as :

(1) Web Tension Control :

Combined with Double - Action Super Cylinder (Model SCD, Ultimate low friction type) and Electro= Pneumatic Transducer (Series-RT).
Printing machine, Paper Processing machine, Plastic Film Processing machine, Textile machine, etc.

(2) Push - down Pressure Control :

Combined with Double-Action BF Cylinder (Model FCD) and Electro-Pneumatic Transducer (Series-RT),
Grinding machine, Abrasion Testing machine, Soil Texture Testing machine, Sheet Cutter, etc.

(3) Volume Boosting and Remote Loading :

Valve control for instrumented equipment, etc.

(4) Different Settings of Secondary Pressure by Remote Control :

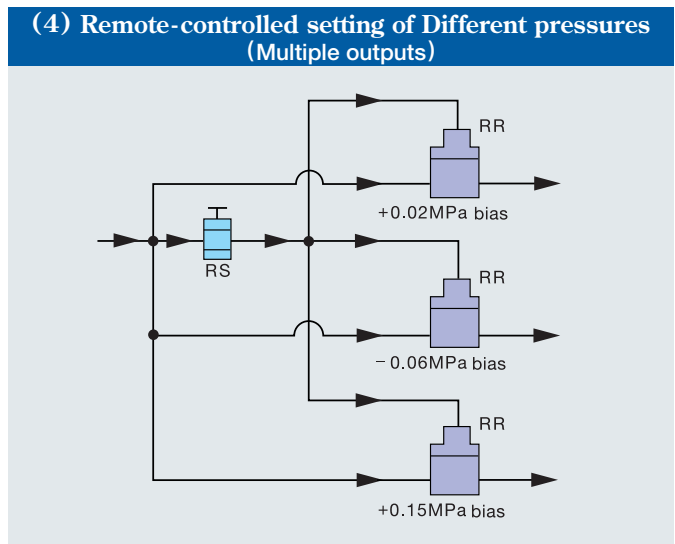
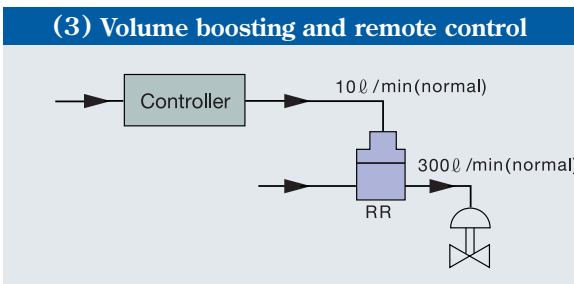
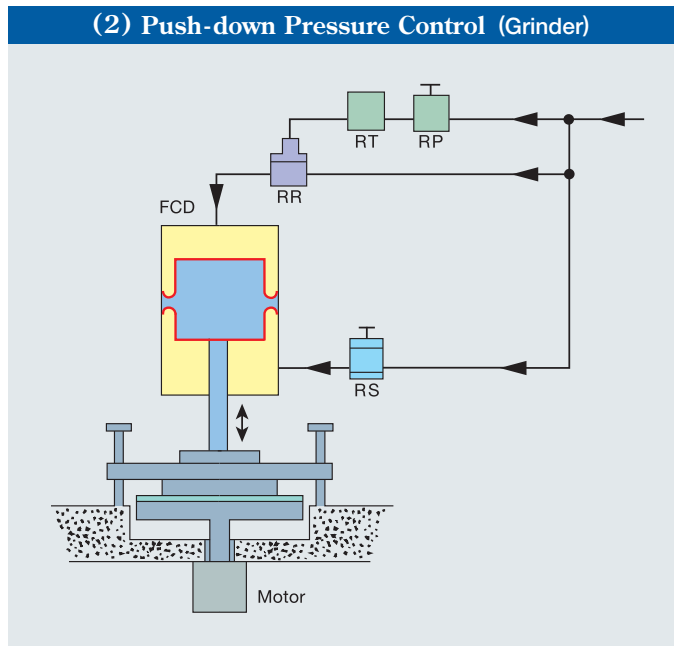
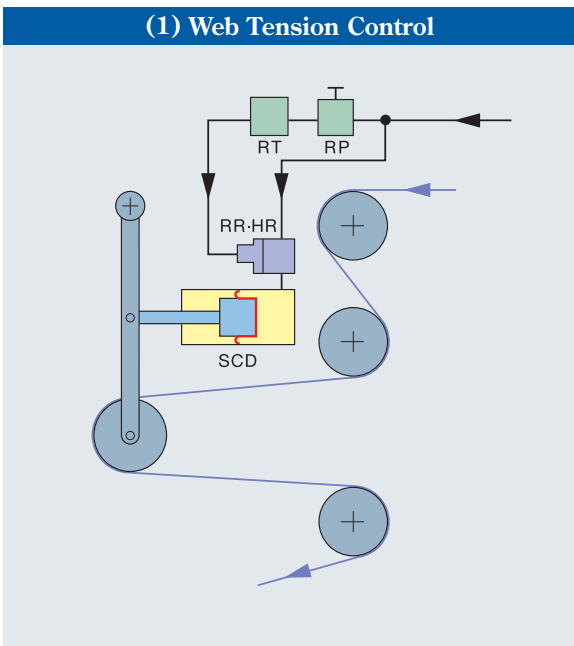

< Note >

- FCD : BF Cylinder (Standard Cylinder. Cat No. KS-570E)
- SCD : BF Cylinder (Super Cylinder. Cat No. KS-570E)
- RP : Precision Air Regulator (Cat No. KS-129E)
- RS : Super Precision Air Regulator (Cat No. KS-128E)
- RR : Super Precision Air Relay (Cat No. KS-128E)
- RR-HR : Super Precision Air Relay (High Relief type, Cat No. KS-128E)
- RT : Precision Electro-Pneumatic Transducer (Cat No. KS-130E)



CAUTION

INSTALLATION AND PRECAUTIONS

PRECAUTIONS COMMON TO SERIES-RS AND SERIES-RR

- ① Flush out all air lines thoroughly to remove dirt and scale before installation is made.
- ② When plumbing connections, apply seal tape onto male threads starting with 3rd. thread back away from end to avoid possibility of getting the tape or sealant into the regulator and air line.

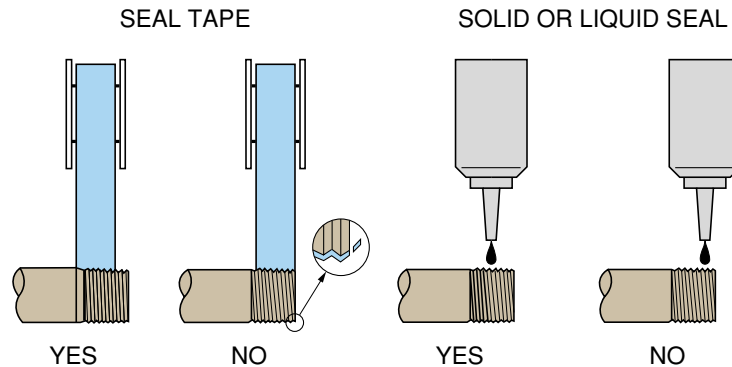

- ③ Drain and dirt in supply pressure line will cause malfunction of Regulator. Be sure an Oil-mist separator together with an Air filter (of 5 micron or less) are installed ahead of the regulator in the air line.
- ④ Locate a Lubricator, if necessary, downstream beyond the regulator.
- ⑤ Connect supply air to IN port and output to OUT port as marked on bottom of Body.
- ⑥ A slight hissing sound of bleed air is the proof of normal air bleed servo control action. Should bleed air be blocked shut, remove Bleed screw and clean Exhaust vent for proper regulating operation.

INSTALLATION (SERIES-RR ONLY)

- ① A change in signal pressure effects a exactly equal change in output pressure. In the input signal pressure line, use a Pressure regulator with accuracy suitable for particular application.
- ② Connect input signal pressure pipe line to either one of two pilot pressure pipe ports on the top of Body.
- ③ Excessive tightening of Bias adjusting screw may cause failure of Capsule.

