

**KOGANEI**

# **ELEWAVE SERIES**

## **Low Profile Electric Slider**

**With point input type controller**  
**With CC-Link type controller *CC-Link***

**OWNER'S MANUAL Ver. 1.0**

[Main unit]

**EW2G10  S**

**EW2G10  H**

**EW2G12  S**

**EW2G12  H**

**EW2G16  S**

**EW2G16  H**

[Controller]

**EW2C-H-NP**

**EW2C-H-PN**

**EW2C-H-CC**

**EW2C-H-CCD**

# Contents

<b>Chapter 1 Safety Precautions</b>	
1-1 Safety.....	2
1-2 Precautions.....	2
<b>Chapter 2 System Configuration</b>	
2-1 Entire system configuration.....	3
2-2 Options and accessories.....	4
2-3 Setting up for operation.....	5
<b>Chapter 3 Main Unit</b>	
3-1 Handling the main unit	
3-1-1 Precautions.....	6
3-2 Mounting	
3-2-1 Mounting the product.....	7
3-2-2 Mounting a workpiece.....	8
3-2-3 Mounting the stroke adjuster.....	8
<b>Chapter 4 Controller</b>	
4-1 Appearance and functions	
4-1-1 Point input type (NPN model and PNP model)	
.....	10
4-1-2 CC-Link type (remote I/O model and remote device model).....	10
4-2 Installation and connection to external devices	
4-2-1 Controller installation.....	11
4-2-2 Connecting the power supply.....	11
4-2-3 Grounding work.....	11
4-2-4 Wiring precautions.....	12
4-2-5 Connecting to the actuator.....	12
4-2-6 Connecting the I/O connector.....	12
4-3 Interface (I/O and CC-Link)	
4-3-1 Connector signal tables.....	12
4-3-1-1 I/O connector signal table.....	12
4-3-1-2 CC-Link connector signal table.....	12
4-3-2 Details of input signals.....	13
4-3-3 Details of output signals.....	14
4-3-4 Input/output circuits.....	14
4-3-4-1 I/O input/output information (point input type controller).....	14
4-3-4-2 CC-Link input/output information (CC-Link remote I/O type controller).....	17
4-3-4-3 CC-Link input/output information (CC-Link remote device type controller).....	18
4-3-4-3-1 Lists of input/output signals and input/output data.....	21
4-3-4-3-2 One-station mode (Remote device: One station occupied).....	22
4-3-4-3-3 Two-station mode (Remote device: Two stations occupied).....	23
4-3-4-3-4 Four-station mode (Remote device: Four stations occupied).....	25
4-3-4-3-5 List of input data.....	27
4-3-4-3-6 Details of input data.....	27
4-3-4-3-7 List of input signals.....	30
4-3-4-3-8 Details of input signals.....	31
4-3-4-3-9 List of output data.....	35
4-3-4-3-10 Details of output data.....	36
4-3-4-3-11 List of output signals.....	41
4-3-4-3-12 Details of output signals.....	41
4-3-5 Timing chart.....	43
4-3-5-1 Timing charts for EW2C-H-NP, EW2C-H-PN, and EW2C-H-CC.....	43
4-3-5-2 Timing charts for EW2C-H-CCD.....	45
4-4 Actuator number setting.....	58
4-5 Point data specifications.....	58
4-6 How to use the size detecting function	
4-6-1 When using an actual workpiece for size detecting range setting.....	60
4-6-2 When using direct input for size detecting function setting.....	60
4-7 Communication	
4-7-1 Communication parameter specifications....	61
4-7-2 Communication cable.....	61
4-7-3 Addresses.....	61
4-7-4 Communication commands.....	61
4-7-5 List of communication commands.....	62
4-7-6 Details of communication commands.....	63
4-8 Parameters	
4-8-1 Parameter setting method.....	69
4-8-2 Explanation of parameters.....	70
4-9 List of errors.....	72
4-10 Easy mode.....	74
4-10-1 I/O connector signal table for easy mode...	74
4-10-2 Details of input signals for easy mode.....	74
4-10-3 Details of output signals for easy mode....	75
4-10-4 Parameters.....	76
4-10-5 Time charts.....	77
<b>Chapter 5 Troubleshooting</b>	
5-1 If a problem occurs.....	80
5-2 Countermeasures for alarms.....	80
5-3 Alarm specifications.....	80
5-3-1 List of alarms.....	81
<b>Chapter 6 Specifications</b>	
6-1 Basic specifications of main unit.....	82
6-2 Basic specifications of the controller.....	83
<b>Chapter 7 Outline Drawings</b>	
7-1 Main unit outline drawings.....	88
7-2 Controller outline drawings.....	104
7-3 Outline drawings for additional parts (Unit: mm).....	105
<b>Chapter 8 Technical Data</b>	
8-1 Accuracy.....	108
8-2 Allowable moment.....	108
8-3 Displacement angle of the table in relation to bending moment.....	109
8-4 Thrust.....	110

# Chapter 1 Safety Precautions

Thank you very much for purchasing the Elewave Series Low Profile Electric Slider. This OWNER'S MANUAL describes the features and how to operate this product. Please read the manual carefully and use the product in a correct manner.

## 1-1 Safety

Always observe the safety instructions and precautions listed in this manual. Neglect of necessary safety measures or improper handling could result in product breakdown or damage, or in accidents that lead to injury to the users (people who set up, operate, or adjust and check, etc.).

## 1-2 Precautions

- (1) Precaution for automatic operations
  - To prevent injury, install an interlock device to prevent the operator from touching the moving parts of the Low Profile Electric Slider.
- (2) Precaution against pinched fingers, etc.
  - Be careful to prevent fingers, etc., from being pinched by the Low Profile Electric Slider's moving parts during transportation, teaching, or operation.
- (3) Operation not allowed in ambient atmospheres containing flammable gases, etc.
  - The Low Profile Electric Slider is not built to explosion-proof specifications. Do not use in ambient atmospheres containing flammable gases, flammable dust, or flammable liquids, etc. It could result in ignitions or explosions.
- (4) Operation not allowed in locations subject to electromagnetic interference, etc.
  - Do not use in locations subject to electromagnetic interference, static electric discharge, or radio frequency interference. It could result in improper operation.
- (5) Safety measures for end effectors (such as pushers)
  - Design and manufacture the end effectors to prevent the occurrence of dangerous situations (such as workpieces popping out or falling) due to cut-off or fluctuation of the power supply (electrical power, air pressure, etc.).
  - If there is a danger that items pushed by the end effector could pop out or fall, take appropriate safety measures that take into consideration the size, mass, temperature, and chemical properties of the items.
- (6) Precautions for controller checks
  - To prevent electric shock when touching the outside terminal and connector of the controller during controller checks, etc., always switch off the controller power and turn off the power supply.
  - Never touch the inside of the controller.
- (7) Response to a damaged or defective Low Profile Electric Slider
  - If any of the damage or defects listed below have been found, continuing use of the Low Profile Electric Slider is dangerous. Immediately stop operation and contact us.

Description of damage or defect	Type of danger
Damage to machine harness or motor wiring	Electric shock, Low Profile Electric Slider's erratic operation
Damage to outer components of the Low Profile Electric Slider	Damaged parts flying off during Low Profile Electric Slider's operation
Abnormal operation of the Low Profile Electric Slider (position deviation, vibrations, etc.)	Low Profile Electric Slider's erratic operation

- (8) Be careful to not touch hot parts of the motor or controller
  - The motor and controller will be very hot in some areas after automatic operations, and touching those areas may cause burns. For checks, etc., first cut the power to the controller, wait for the areas to cool down, confirm the cooled temperature, and then handle those areas.
- (9) Protective grounding
  - Always ground the controller to protect it against electric shock.
- (10) Secure the cable while taking care not to apply excessive twisting or tensile force to the connector.
- (11) Depending on the model of the Low Profile Electric Slider, the table does not move by an external force. Do not apply excessive force or shock to the table.
- (12) For the precautions for the product, read through "Safety Precautions" and "Handling Instructions and Precautions" in the homepage or general catalog before use.

# Chapter 2 System Configuration

## 2-1 Entire system configuration

The Low Profile Electric Slider consists of the following major components.

### ● Point input type controller

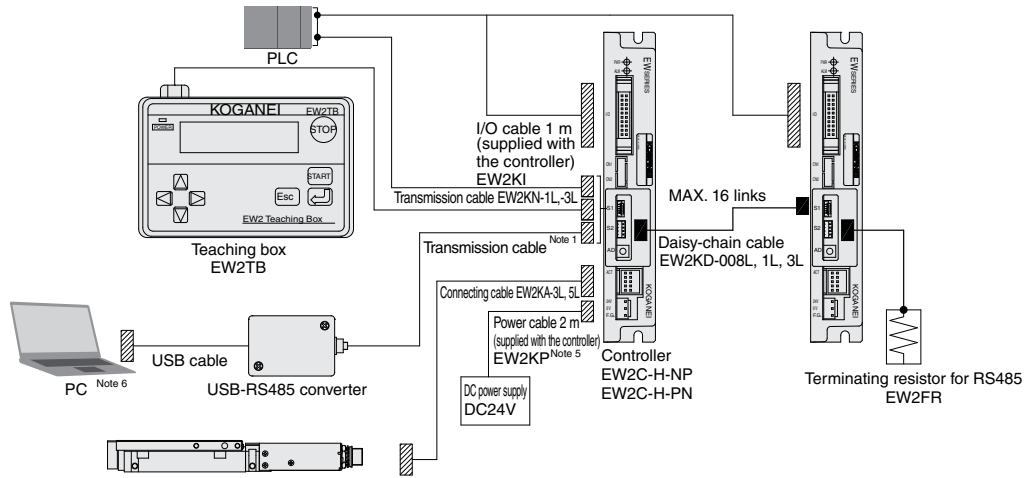

### ● CC-Link type controller ①

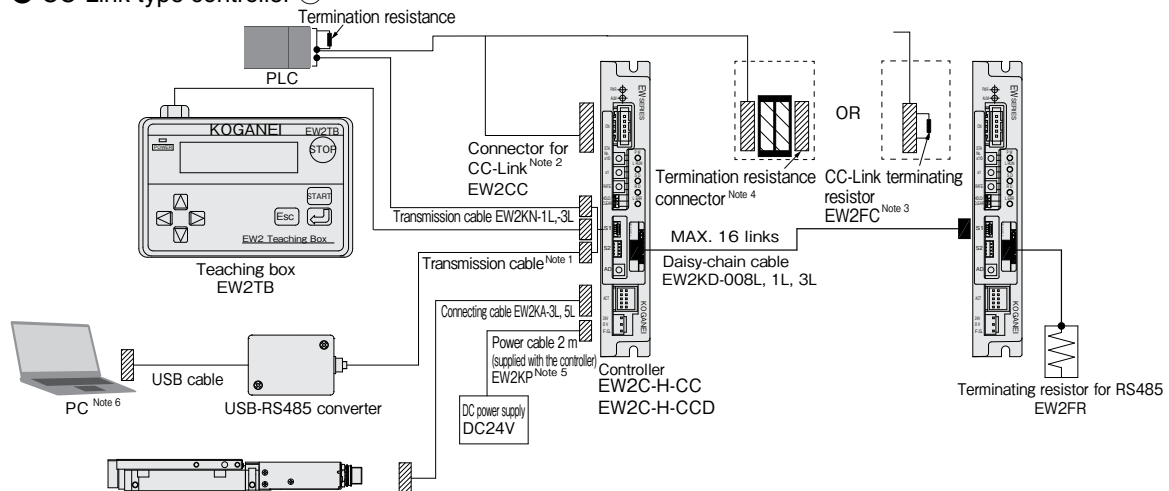

### ● CC-Link type controller ②

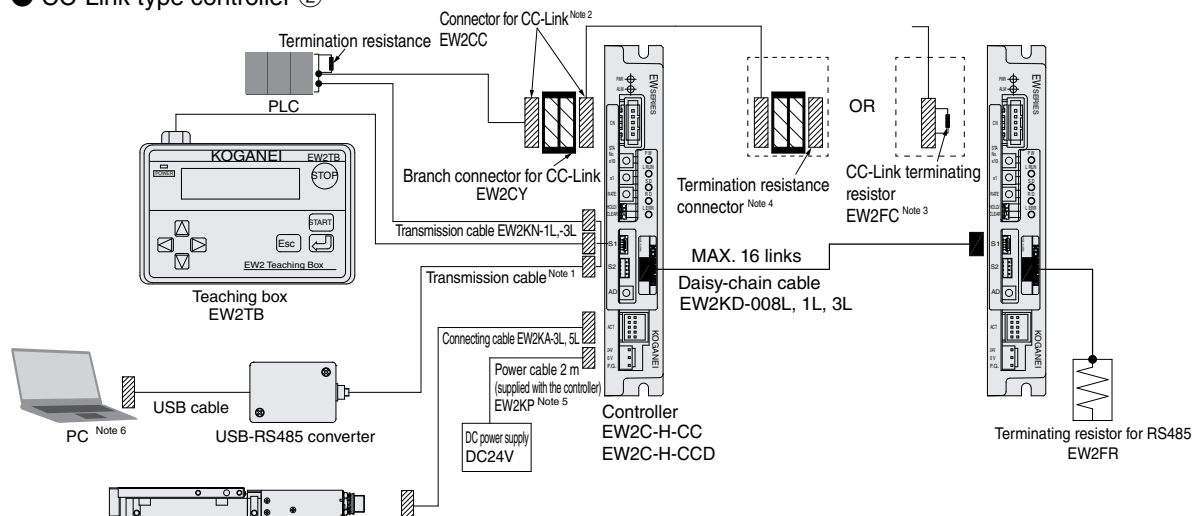

Note 1: The communication cable is selectable from the following.

- IBM2A-H1 : USB-RS485 converter, w/ USB cable
- IBM2A-H1-N: USB-RS485 converter, w/o USB cable
- EW2KN : For communication

Note 2: Only the CC-Link connector is provided. The cable must be prepared by the customer.

Note 3: If EW2C-H-CC□ is used as the termination unit, be sure to use a CC-Link terminating resistor (EW2FC) or terminating resistor connector.

Note 4: The terminating resistor connector must be prepared by the customer.

[Recommendation] 35T05-6M00-B0M GF, manufactured by 3M

Note 5: It is recommended to install a noise filter. (Refer to P. 11.)

Note 6: The controller setting support software can be downloaded for free from our homepage.

## 2-2 Options and accessories

### 1. Controller

- When Option -NP is selected, the controller EW2C-H-NP and the following accessories are included in the package.

Please confirm at time of purchase.

Power cable (EW2KP): 1 pc.

I/O cable (EW2KI): 1 pc.

- When Option -PN is selected, the controller EW2C-H-PN and the following accessories are included in the package.

Please confirm at time of purchase.

Power cable (EW2KP): 1 pc.

I/O cable (EW2KI): 1 pc.

- When Option -CC is selected, the controller EW2C-H-CC and the following accessories are included in the package.

Please confirm at time of purchase.

Power cable (EW2KP): 1 pc.

CC-Link connector (EW2CC): 1 pc.

CC-Link terminating resistor (EW2FC): 1 set

- When Option -CCD is selected, the controller EW2C-H-CCD and the following accessories are included in the package.

Please confirm at time of purchase.

Power cable (EW2KP): 1 pc.

CC-Link connector (EW2CC): 1 pc.

CC-Link terminating resistor (EW2FC): 1 set

### 2. DIN rail mounting plate

- When Option -DP is selected, the DIN rail mounting plate EW2DP (with two mounting screws) is included in the package.

Please confirm at time of purchase.

### 3. Positioning pin

- When Option -P is selected, the positioning pin is included in the package.

EW2G10 <input type="checkbox"/>	EW2P-3
EW2G12 <input type="checkbox"/>	EW2P-4
EW2G16 <input type="checkbox"/>	

Please confirm at time of purchase.

### 4. Connecting cable

- When Option -3L or -5L is selected, the cable EW2KA-3L (cable length: 3 m) or EW2KA-5L (cable length: 5 m) for connecting the Low Profile Electric Slider main unit and controller is included in the package. Please confirm at time of purchase.

## 2-3 Setting up for operation

	Procedure	Reference section
Installation and connection	Installation	3-2 4-2
	↓	
	Connections	Connect the power supply, controller, actuator, and personal computer or teaching box. 4-1 4-2
	↓	
	Turning on the power	4-2
	↓	
Settings	Setting the actuator number	Set the specified actuator number. <sup>Note</sup> 4-4
	↓	
	Changing parameters	Configure parameter data in accordance with your usage conditions. 4-8
	↓	
	Point data input	Enter point data suitable for the operation. 4-5
	↓	
	Test operations	Check that the operation is normal. 4-3
	↓	
Operations	Operations	Use the set point commands and START signal to run the desired operation. For continuous operations, use a programmable controller or other external devices to control operations. 4-3

Note: When you purchase the actuator and controller as a set, the controller's actuator number is set to the specified actuator number at the time of shipping.

Note: When the controller was purchased alone, be sure to set the actuator number for the connected model of the actuator.

Model	Actuator No.
EW2G10□S-10	10
EW2G10□S-30	11
EW2G10□S-50	12
EW2G10□H-10	15
EW2G10□H-30	16
EW2G10□H-50	17

Model	Actuator No.
EW2G12□S-20	20
EW2G12□S-40	21
EW2G12□S-60	22
EW2G12□S-80	23
EW2G12□H-20	25
EW2G12□H-40	26
EW2G12□H-60	27
EW2G12□H-80	28

Model	Actuator No.
EW2G16□S-20	30
EW2G16□S-40	31
EW2G16□S-60	32
EW2G16□S-100	33
EW2G16□H-20	35
EW2G16□H-40	36
EW2G16□H-60	37
EW2G16□H-100	38

# Chapter 3 Main Unit

## 3-1 Handling the main unit

### 3-1-1 Precautions

- (1) Do not apply excessive external force or shock to the workpiece mounted on the table or main unit. Applying excessive external force or shock could cause the parts to be damaged or move out of alignment. Depending on the model of the Low Profile Electric Slider, the table does not move by an external force. To move the table manually, use the hexagonal hole or dial provided for moving the table. (When using the dial, rotate it with a thin rod (screwdriver, hex wrench, etc.).)

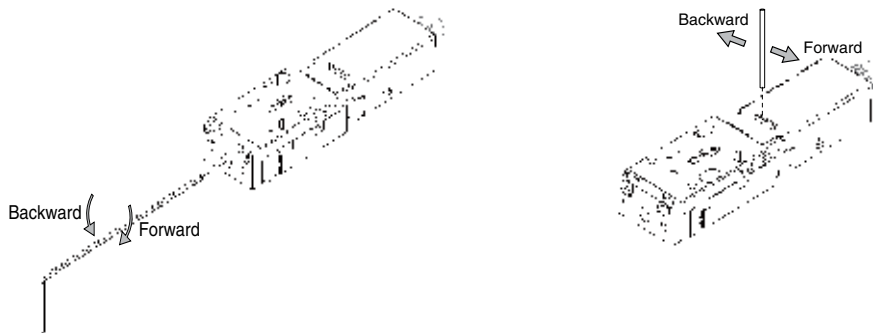

- (2) Restrictions on operations  
The motor could get hot under certain operating conditions. Set the stop time to 0.5 seconds or more. Also, use the product within the operating temperature range. Use of the product in conditions exceeding the operation limits could damage or burn the motor.
- (3) Operating sound  
The operating sound could become loud depending on the operating speed, mounting position, and workpiece conditions, but this is not a malfunction.
- (4) Use the main unit and the controller in locations where there is little dust and dirt. Using them in locations where there are large amounts of dirt and dust could create the risk of abnormal operation.
- (5) With too short an operating distance, the maximum speed may not be reached depending on acceleration and deceleration.
- (6) The takt time may change depending on the mounting position and workpiece conditions.
- (7) Since this product uses a finite track guide, if reciprocating motion is repeated over a stroke shorter than that required for operation, the steel balls could get out of alignment due to a microslip, resulting in looseness. When selecting the model, select one with a stroke close to that in actual use and ensure that the stroke is equal to or larger than that required for operation.

Model	Stroke range [mm]	Model	Stroke range [mm]	Model	Stroke range [mm]
EW2G10□-10	0 or more	EW2G12□-20	0 or more	EW2G16□-20	0 or more
EW2G10□-30	15 or more	EW2G12□-40	20 or more	EW2G16□-40	20 or more
EW2G10□-50	30 or more	EW2G12□-60	40 or more	EW2G16□-60	40 or more
-	-	EW2G12□-80	60 or more	EW2G16□-100	65 or more

- (8) Secure the cable while taking care not to apply twisting or tensile force to the connector. Also, secure the cable so that the connector is not subject to any bending moment. (The same applies to the controller connector.)
- (9) If reciprocating motion is repeated over a short distance, the grease film could break. It is recommended to repeat reciprocating motion five times or so with full stroke every 5,000 to 10,000 reciprocations so as to recover the grease film.
- (10) To stop the movement with the adjustment stopper, use pushing mode. Using the stopper with positioning mode could cause an error or damage.
- (11) When adjusting the angle by selecting the cable direction (-1, -2, -3, or -4), adjust the angle within  $\pm 180^\circ$  from the initial angle. Failure to do so could result in disconnection.

## 3-2 Mounting

- (1) You can mount the product in any position, but the flatness of the mounting surface of the mating part, such as the workpiece and base, must be 0.02 mm or less. Poor flatness could result in a loose guide or increased rolling resistance, or adversely affect the service life.
- (2) Avoid scratching or denting the mounting surface of the slider, as doing so could adversely affect the flatness.
- (3) If there is a large shock, install a support mechanism to the main unit in addition to the bolts.
- (4) When mounting a workpiece or bracket, be careful not to apply strong shock or excessive moment to the guide. When mounting a workpiece or bracket on the table, secure it while holding the table, and when mounting it on the main unit, secure it while holding the main unit. Applying strong shock or excessive moment to the guide will lead to poor guide accuracy.
- (5) Make sure that the mounting bolts have sufficient strength. When mounting a workpiece or bracket, tighten the bolts to an appropriate torque within the allowable range.
- (6) If there is a risk of bolts loosening due to shocks or vibrations, consider taking measures to prevent them from loosening.
- (7) For the positioning pin hole, use the clearance-fit stepped pin (option). Press-fitting the pin could cause damage to the guide due to an excessive load. The pin hole on the table is a through hole. Using a pin other than the stepped pin could cause a contact between the pin and main unit, resulting in a failure.
- (8) Make sure that the main unit or workpiece mounting bolts are equal to or shorter than the maximum thread depth. A bolt longer than the maximum thread depth could reach and damage the main unit.

### 3-2-1 Mounting the product

EW2G□, EW2G□C



Model	Bolt used	Maximum tightening torque N·m	D mm	F mm
EW2G10□	M3×0.5	1.14	7	1.5
EW2G12□	M4×0.7	2.7	6	3.5
EW2G16□	M4×0.7	2.7	9	6

Model	Bolt used	Maximum tightening torque N·m	E mm
EW2G10□	M4×0.7	2.7	7
EW2G12□	M5×0.8	5.4	6
EW2G16□	M5×0.8	5.4	9

Note: EW2G□R is mounted by direct mounting only.

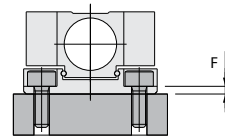
EW2G□R<sup>Note</sup>



### 3-2-2 Mounting a workpiece

EW2G□, EW2G□C

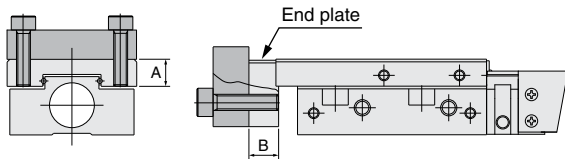

EW2G□R

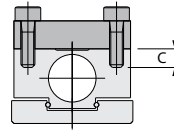

Model	Bolt used	Maximum tightening torque N·m	Maximum thread depth A mm	Maximum thread depth B mm	Maximum thread depth C mm
EW2G10□	M3×0.5	0.63	5	5	4
EW2G12□	M4×0.7	1.5	7	6	7
EW2G16□	M4×0.7	1.5	8.5	7	9.5



- Make sure that the workpiece mounting bolts are equal to or shorter than the maximum thread depth.  
A bolt longer than the maximum thread depth could reach and damage the main unit.
- EW2G□R does not have an end plate.

### 3-2-3 Mounting the stroke adjuster

When mounting the stroke adjuster, which is an optional part, secure it appropriately with the following tightening torques.

① Stopper



② Bracket A



Model	① Stopper		② Bracket A	
	Bolt used	Tightening torque N·m	Bolt used	Tightening torque N·m
EW2G10□	M2.5×0.45	0.65	M3×0.5	0.63
EW2G12□	M3×0.5	1.14	M4×0.7	1.5
EW2G16□	M4×0.7	2.0	M5×0.8	3.0



# Chapter 4 Controller

## 4-1 Appearance and functions

### 4-1-1 Point input type (NPN model and PNP model)

- ① POWER LED  
Lights when the power supply is turned on.
- ② ALARM LED  
Shows the state of the controller. (See the table below on the right)
- ③ I/O connector  
Use the supplied I/O cable for connecting to sensor switches or an external programmable controller, etc.
- ④ S1 connector  
This is the connector for connecting the communication cable and teaching box.
- ⑤ S2 connector  
This is the connector used for daisy chain connection.
- ⑥ Address switch  
Sets the address. (0 to F, 16 patterns)
- ⑦ ACT connector  
This is the connector for connecting to the main unit.
- ⑧ Power connector  
Connects the supplied power cable to supply 24 VDC.

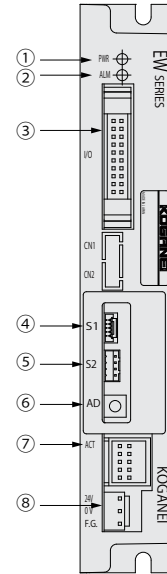

Description	LED state
Alarm occurs	Lights
Error occurs	Quick blinking (ON: 0.25s, OFF: 0.25s)
Origin return not completed	Slow blinking (ON: 0.5s, OFF: 1.5s)
Normal	Not lit

### 4-1-2 CC-Link type (remote I/O model and remote device model)

- ① POWER LED  
Lights when the power supply is turned on.
- ② ALARM LED  
Shows the state of the controller. (See the table below on the right)
- ③ CC-Link connector  
This is the connector for connecting to an external programmable controller etc.  
\* The cable must be prepared by the customer.
- ④ and ⑤ CC-Link station number setting switch  
Sets the CC-Link station number. (Set a value from 1 to 64.)  
For the remote device model, this range depends on the number of stations used. Refer to P. 18.
- ⑥ CC-Link baud rate setting switch  
Sets the CC-Link baud rate. (Set a value from 0 to 4.)
- ⑦ Link error input port data selection switch  
Sets the input port data state in case of a link error.  
(Left: HOLD Right: CLEAR)

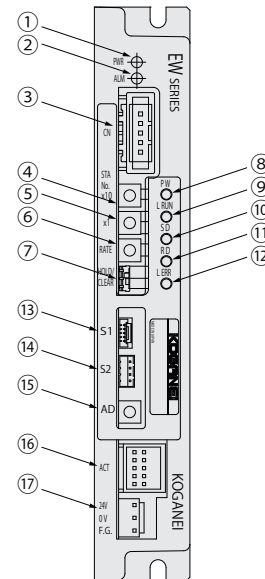

Description	LED state
Alarm occurs	Lights
Error occurs	Quick blinking (ON: 0.25s, OFF: 0.25s)
Origin return not completed	Slow blinking (ON: 0.5s, OFF: 1.5s)
Normal	Not lit

- ⑧ to ⑫ CC-Link status indicator LED  
(See Table 1.)
- ⑬ S1 connector  
This is the connector for connecting the communication cable and teaching box.
- ⑭ S2 connector  
This is the connector used for daisy chain connection.
- ⑮ Address switch  
Sets the address.
- ⑯ ACT connector  
This is the connector for connecting to the main unit.
- ⑰ Power connector  
Connects the supplied cable to supply 24 VDC.

[Table 1]

Indication	Description
⑧ PW	Turns on when the power is turned on.
⑨ L RUN	Turns on when normal data is received from the master station.
⑩ SD	Turns on when data is transmitted.
⑪ RD	Turns on when data is received.
⑫ L ERR	Turns on when a transmission error occurs and turns off when the timeout period is reached. Turns on when the transmission rate is set incorrectly.

## 4-2 Installation and connection to external devices

### 4-2-1 Controller installation

#### (1) Installation

Use M4 screws in the 5-mm U-grooves on the back of the controller to secure it to a rack that has good thermal conductivity.

#### (2) Installation (DIN rail installation)

If you have purchased a DIN rail mounting plate, use the 5-mm U-grooves on the back of the controller to secure it to the DIN rail mounting plate with the supplied M4 screws. Then, install the controller to the DIN rail you have arranged.

#### (3) Installation environment

- Install the controller in a location with an ambient temperature of 0 to 40°C, humidity of 35 to 85%, and no condensation.
- Install the controller so there is adequate space around it (20 mm or more) with good ventilation.
- Avoid installations in locations subject to corrosive gases, such as sulfuric acid or hydrochloric acid, as well as ambient atmospheres containing flammable gases or liquids, etc.
- Install the controller where there is little dust or dirt.
- Avoid installations in locations subject to metal chips, oil, or water from other equipment.
- Avoid installations in locations subject to electromagnetic or electrostatic noises.
- Install the controller in a location that is free from large vibrations.

### 4-2-2 Connecting the power supply

#### (1) Power supply

- Connect the power cable to a power supply with a capacity of 24 VDC $\pm$ 10% and 1.6 A or more.
- Connector: B3PS-VH (JST Mfg. Co., Ltd.)

Connector pin number table

No.	Signal name	Wire color	Description
1	24 V	Red	Power supply
2	0 V	Blue	
3	FG	Green	Ground

#### Caution:

- **Supply of an unstable power voltage to the controller may cause alarm shutdowns or abnormal operation. Use adequate care, therefore, in selecting a 24-V power supply. Ensure as stable a power supply as possible.**

#### (2) How to connect the power supply

- Use the supplied power cable to connect to the power supply. Connect the polarity correctly to prevent mis-wiring. Wrong connections could result in fire or other dangerous conditions.
- It is recommended to use a noise filter for the power cable. (Recommended type: RSEN-2006, manufactured by TDK-Lambda)
- It is recommended to twist the 24V and 0V power cables.

#### Caution:

- **The EW2C-H controller does not have a power switch and an emergency stop function. Always install an appropriate power cut-off (isolator) device for the overall system of equipment.**

#### Danger:

- **Before wiring to the controller, always turn off the power to the overall system of equipment to avoid the danger of electric shock. There is a risk of electric shock.**

#### (3) Insulation resistance/Dielectric strength test

Never conduct an insulation resistance test or dielectric strength test on the controller.

### 4-2-3 Grounding work

- Always ground the equipment to prevent electric shock to people if there is electric leakage and to prevent erratic operation due to electrical noise.
- We strongly recommend type 3 grounding (grounding resistance of 100  $\Omega$  or less) or better.
- For the ground terminal of the controller, use the F.G. wire of the power cable.
- When EW2C-H-CC or EW2C-H-CCD (CC-Link type) is grounded, it is recommended that the length of the F.G. wire of the power cable be 250 mm or less. If it is longer than 250 mm, communication may be affected by external noise.

#### 4-2-4 Wiring precautions

For conformity to the CE marking standards, the following measures are required, for example, when connecting the controller to peripheral devices.

- Install a clamp filter (two turns) to the power cable.
- Install a clamp filter to the controller side of the connecting cable.
  - EW2C-H-NP: 1 pc. (2 turns)
  - EW2C-H-PN: 1 pc. (2 turns)
  - EW2C-H-CC: 3 pcs. (2 turns each)
  - EW2C-H-CCD: 4 pcs. (2 turns each)

[Recommendation] ZCAT3035-1330, manufactured by TDK

- Do not coil a connecting cable or bundle multiple cables.
- The CC-Link cable must be 30 mm or less long and used with the ground wire connected.
- To operate the controller with the teaching box (EW2TB) connected, install a clamp filter (two turns) to the teaching box cable.

#### 4-2-5 Connecting to the actuator

Connect the actuator connecting cable to the ACT connector on the front of the controller. Turn off the power supply before performing the connection. Be sure that the actuator connecting cable is firmly inserted into the connector.

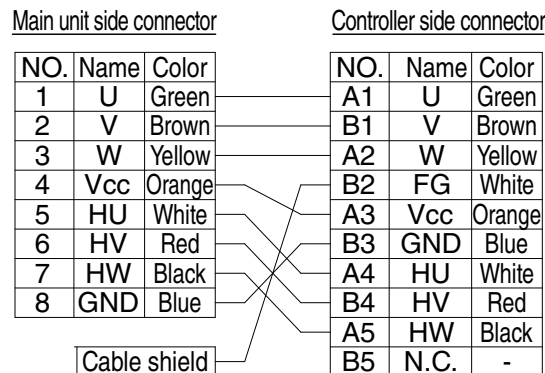

#### 4-2-6 Connecting the I/O connector

Connect the I/O connector to a programmable controller or other external device.

### 4-3 Interface (I/O and CC-Link)

#### 4-3-1 Connector signal tables

##### 4-3-1-1 I/O connector signal table

NO.	Wire color	Signal name	Description	NO.	Wire color	Signal name	Description
01	Brown	POS0	Point setting	02	Red	POS1	Point setting
03	Orange	POS2	Point setting	04	Yellow	POS3	Point setting
05	Green	POS4	Point setting	06	Blue	START	Start signal
07	Purple	STOP	Stop signal	08	Gray	ORG	Return to origin signal
09	White	READY	Preparation completed output	10	Black	BUSY	Command execution in progress output
11	Brown	INPOS	Positioning completed output	12	Red	HOLD	Pushing completed output
13	Orange	24G	- common	14	Yellow	N.C.	N.C.
15	Green	24V GND	Ground	16	Blue	24V IN	24-V input
17	Purple	N.C.	N.C.	18	Gray	24V	+24V
19	White	FG	Frame ground	20	Black	FG	Frame ground

##### 4-3-1-2 CC-Link connector signal table

No.	Signal name	Description
1	DA	Signal line
2	DB	Signal line
3	DG	Digital GND
-		
4	SLD	Shield

### 4-3-2 Details of input signals

There are 8 dedicated command inputs as input signals.

#### ○Dedicated command inputs

Dedicated command inputs are inputs to control from an external device, such as a programmable controller.

To accept the START and ORG inputs, the READY, BUSY, and STOP signals must meet the following conditions.

- READY output : ON
- BUSY output : OFF
- STOP input : OFF

\* The START and ORG inputs are accepted when the OFF state is switched to the ON state (the moment when the contact closes).

Whether the controller has accepted the command or not can be confirmed by monitoring the BUSY output.

#### ■ Operation start input (START)

From the current position, the tooling moves by the data of the point no. specified in POS0 to POS4.

##### Caution:

**To execute START, it is necessary to confirm the entry states of POS0 to POS4.**

#### ■ Return to origin input (ORG)

Executes return to origin in the direction of the origin return specified in the parameter (PRM5). It is always necessary to execute return to origin after the power is turned on.

#### ■ Operation stop input (STOP)

This is an input to stop the actuator's movement temporarily.

Turning this input ON (closing the contact) while the actuator is operating, or while it is executing return to origin, stops the actuator's movement. While this input is in the ON state (the contact is in a closed state), it is not possible to execute any dedicated command from I/O, any program using communication, or any return to origin command.

#### ■ POS0 to POS4

These are inputs for connecting to output circuits of the programmable controller or other devices, and for specifying the point no.

Examples of point specification

Point No. \ POS No.	POS4 (2 <sup>4</sup> )	POS3 (2 <sup>3</sup> )	POS2 (2 <sup>2</sup> )	POS1 (2 <sup>1</sup> )	POS0 (2 <sup>0</sup> )
P0	OFF	OFF	OFF	OFF	OFF
P1	OFF	OFF	OFF	OFF	ON
P3	OFF	OFF	OFF	ON	ON
P7	OFF	OFF	ON	ON	ON
P15	OFF	ON	ON	ON	ON
P31	ON	ON	ON	ON	ON

### 4-3-3 Details of output signals

There are 4 output signals: READY, BUSY, INPOS, and HOLD.

ON and OFF refer to the turning on and off of the output transistor.

#### ○Dedicated outputs

These outputs are for signal interaction with a programmable controller, etc.

##### ■ Preparation completed output (READY)

When the controller system is operating normally, this output is set to ON. If an alarm is issued, this output is set to OFF and the motor enters a free state.

##### ■ Command execution in progress output (BUSY)

This signal is set to ON when a dedicated command input (START) is being executed or when a command is being executed by using communication. When the BUSY signal is ON, no dedicated command input (START) is accepted, and no command is accepted by using communication.

##### **Caution:**

**Always turn off dedicated command inputs when BUSY is ON. Leaving input ON prevents BUSY from switching to OFF, even after completing execution of a command.**

##### ■ Positioning operation completed output (INPOS)

This signal turns OFF whenever a dedicated command input (START) is accepted, and then turns ON when the positioning operation execution process is completed normally, or when the size detecting function is set. If an error occurs during execution, or if STOP has been input, the signal remains unchanged in the OFF state.

##### ■ Pushing operation completed output (HOLD)

This signal turns OFF whenever a dedicated command input (START) is accepted, and then turns ON when the pushing operation execution process is completed normally. If an error occurs during execution, or if STOP has been input, the signal remains unchanged in the OFF state.

### 4-3-4 Input/output circuits

This section provides the specifications for the input/output circuits and wiring examples. Refer to this example when connecting to the programmable controller or other external equipment.

#### 4-3-4-1 I/O input/output information (point input type controller)

##### (1) Input/output circuit specifications

##### ○Input power supply

Input voltage : 24 V $\pm$ 10%

##### ○Input circuit

Isolation method : Photocoupler isolation

Input response : 30 ms or less

Input current : 5 mA/24 VDC

Input sensitivity : ON current Min. 3 mA

OFF current Max. 1 mA

##### ○Output circuit

Isolation method : Photocoupler isolation between internal circuits and output transistor

Output terminal : Open collector output\*

Output response : 1 ms or less

Maximum output current : 30 mA/24 VDC per 1 output

Residual ON voltage : 1.5 V or less

\* The NPN model has an NPN output, and the PNP model has a PNP output.

## (2) Wiring examples (NPN model)

- When the controller's internal power supply is used

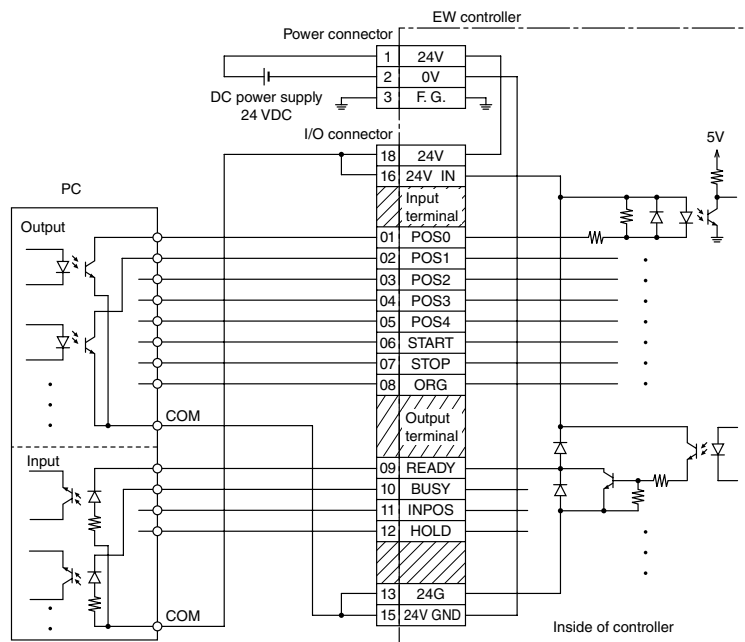

\* Even when only the input or output is used, connect 13-15 and 16-18.

- When a separate power supply is used without using the controller's internal power supply

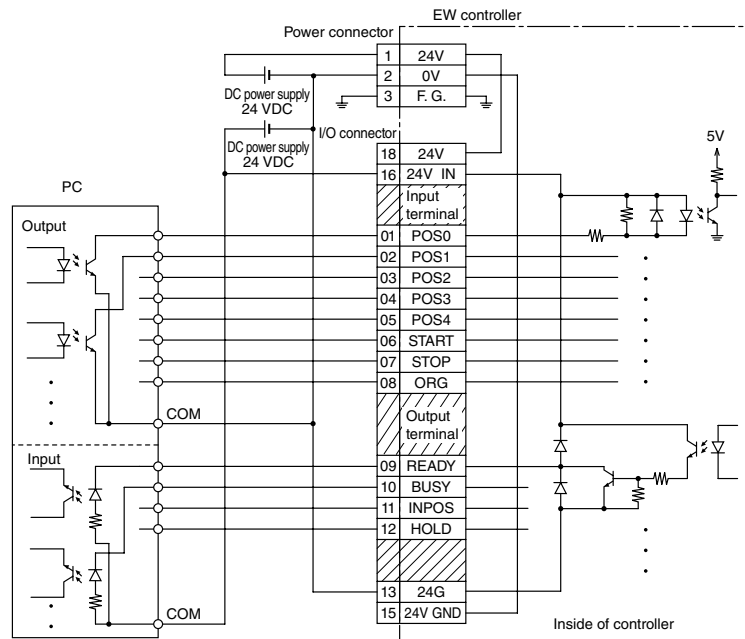

\* Even when only the input or output is used, connect the power supply to 13 and 16.



(3) Wiring examples (PNP model)

- When the controller's internal power supply is used

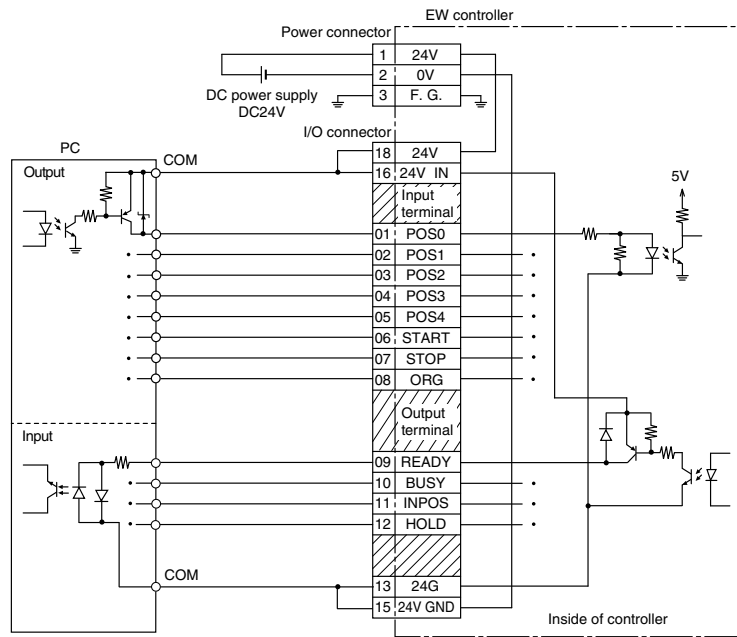

\* Even when only the input or output is used, connect 13-15 and 16-18.

- When a separate power supply is used without using the controller's internal power supply

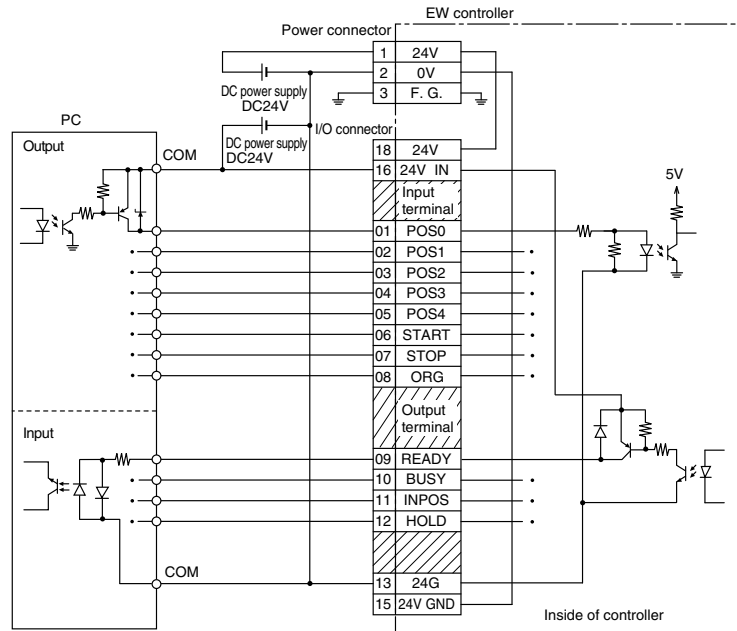

\* Even when only the input or output is used, connect the power supply to 13 and 16.

## 4-3-4-2 CC-Link input/output information (CC-Link remote I/O type controller)

## (1) Correspondence table between the master station and buffer memory

EW2C-H-CC uses remote I/O (when one station is occupied, 16 inputs/16 outputs).

Example) When the station number is set to "01"

Master station buffer area

Station No.	Remote input (RX)	Remote output (RY)
1	RX00 to RX0F	RY00 to RY0F
	RX10 to RX1F	RY10 to RY1F
2	RX20 to RX2F	RY20 to RY2F
	RX30 to RX3F	RY30 to RY3F
3	⋮	⋮
⋮	⋮	⋮
⋮	⋮	⋮
64	RX7E0 to RX7EF	RY7E0 to RY7EF
	RX7F0 to RX7FF	RY7F0 to RY7FF

Example) When the station number is set to "01"

EW2C-H-CC's I/O memory map

Remote input (RX)		Remote output (RY)	
RX00	READY	RY00	Unused
RX01	BUSY	⋮	
RX02	INPOS	⋮	
RX03	HOLD	⋮	
RX04	Unused	⋮	Unused
⋮		⋮	
⋮		⋮	
RX0F		RY0F	
RX10	Unused	RY10	POS0
⋮		RY11	POS1
⋮		RY12	POS2
⋮		RY13	POS3
⋮		RY14	POS4
⋮		RY15	START
⋮		RY16	STOP
⋮		RY17	ORG
⋮	RY18	Unused	
RX1F	⋮		RY1F

## (2) Wiring example

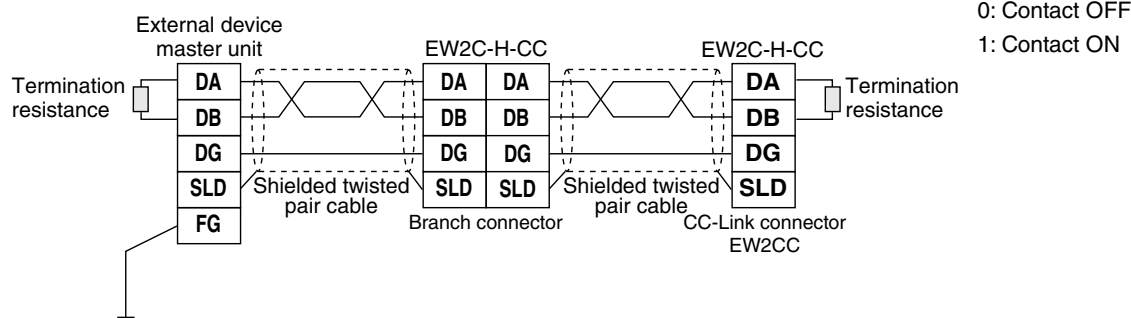

\* Use a cable recommended by CC-Link Partner Association.

Connect the terminating resistor between end station terminals DA and DB.

\* Use a "110 Ω 1/2 W" terminating resistor for the CC-Link dedicated cable and Ver.1.10-compatible CC-Link dedicated cable, and a "130 Ω 1/2 W" terminating resistor for the CC-Link dedicated high-performance cable.

\* Make sure grounding is done properly.

## (3) CC-Link station number setting switches

You can set the station number with the "STA NO. x10,x1" rotary switches on the front of the controller.

Example) x10 switch: 3, x1 switch: 9 → The station number is set to "39."

Note: Set the station number to a value from 1 to 64.

## (4) CC-Link baud rate setting switch

You can set the baud rate with the "RATE" rotary switch on the front of the controller.

Settings	0	1	2	3	4
Transmission rate	156kbps	625kbps	2.5Mbps	5Mbps	10Mbps

Note: Set the baud rate to a value from 0 to 4. Also, select the appropriate baud rate according to the transmission rate of the master unit you are using.

### 4-3-4-3 CC-Link input/output information (CC-Link remote device type controller)

#### (1) Setting operation mode

Select operation mode using parameters.

Set parameter No. 62 (setting of the number of CC-Link stations) by using the support software.

(Refer to P. 72.)

You can also set operation mode by writing the station to occupy via CC-Link (refer to P. 54).

Setting value	Operation mode	No. of stations occupied
1	One-station mode	1 station
2	Two-station mode	2 stations
4	Four-station mode	4 stations

#### (2) Setting the station number

You can set the station number with the “CC-Link station number setting switch” on the front of the controller.

Setting range: 1 to 64 (when one station is occupied), 1 to 63 (when two stations are occupied), 1 to 61 (when four stations are occupied)

#### (3) Wiring example

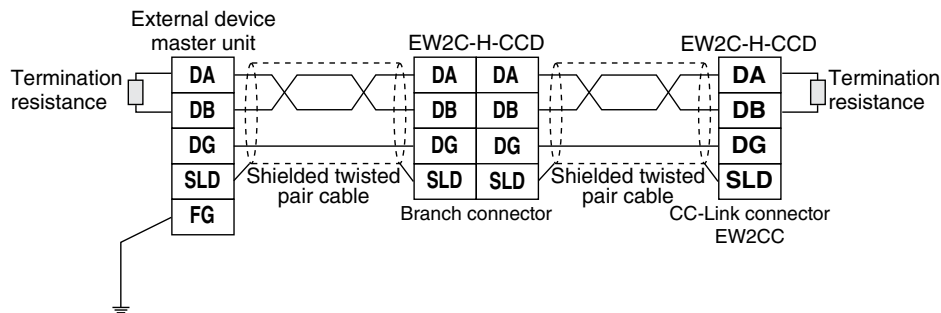

#### (4) CC-Link station number setting switches

You can set the station number with the “STA NO. x10,x1” rotary switches on the front of the controller.

Example) x10 switch: 3, x1 switch: 9 → The station number is set to “39.”

Note: Set the station number to a value from 1 to 64.

#### (5) CC-Link baud rate setting switch

You can set the baud rate with the “RATE” rotary switch on the front of the controller.

Settings	0	1	2	3	4
Transmission rate	156kbps	625kbps	2.5Mbps	5Mbps	10Mbps

Note: Set the baud rate to a value from 0 to 4. Also, select the appropriate baud rate according to the transmission rate of the master unit you are using.

\* : When you have changed the number of stations occupied, station number, or baud rate, turn the power off and on again.

## (6) Communicating with the master station

The address allocation of each operation mode is as follows:

## PLC address

Remote input (RX)	Number of occupied addresses		
	1-address occupation	2-address occupation	4-address occupation
RX (n+0)0 to RX (n+0)F	Domain	Domain	Domain
RX (n+1)0 to RX (n+1)F	System area		
RX (n+2)0 to RX (n+2)F		System area	
RX (n+3)0 to RX (n+3)F			
RX (n+4)0 to RX (n+4)F			
RX (n+5)0 to RX (n+5)F			
RX (n+6)0 to RX (n+6)F			
RX (n+7)0 to RX (n+7)F			System area

Remote output (RY)	Number of occupied addresses		
	1-address occupation	2-address occupation	4-address occupation
RX (n+0)0 to RX (n+0)F	Domain	Domain	Domain
RX (n+1)0 to RX (n+1)F	System area		
RX (n+2)0 to RX (n+2)F		System area	
RX (n+3)0 to RX (n+3)F			
RX (n+4)0 to RX (n+4)F			
RX (n+5)0 to RX (n+5)F			
RX (n+6)0 to RX (n+6)F			
RX (n+7)0 to RX (n+7)F			System area

Note: The occupied area means the area occupied depending on the setting of the number of remote device stations.

For details on each allocation, refer to the pages describing the allocation.

The system area means the system area of each remote device station.

Note: n indicates the register address of each station.

## PLC address

Remote register input (RW <sub>r</sub> )	Number of occupied addresses		
	1-address occupation	2-address occupation	4-address occupation
RW <sub>r</sub> (n+0)	Domain	Domain	Domain
RW <sub>r</sub> (n+1)			
RW <sub>r</sub> (n+2)			
RW <sub>r</sub> (n+3)			
RW <sub>r</sub> (n+4)			
RW <sub>r</sub> (n+5)			
RW <sub>r</sub> (n+6)			
RW <sub>r</sub> (n+7)			
RW <sub>r</sub> (n+8)			
RW <sub>r</sub> (n+9)			
RW <sub>r</sub> (n+A)			
RW <sub>r</sub> (n+B)			
RW <sub>r</sub> (n+C)			
RW <sub>r</sub> (n+D)			
RW <sub>r</sub> (n+E)			
RW <sub>r</sub> (n+F)			

Remote register output (RW <sub>w</sub> )	Number of occupied addresses		
	1-address occupation	2-address occupation	4-address occupation
RW <sub>w</sub> (n+0)	Domain	Domain	Domain
RW <sub>w</sub> (n+1)			
RW <sub>w</sub> (n+2)			
RW <sub>w</sub> (n+3)			
RW <sub>w</sub> (n+4)			
RW <sub>w</sub> (n+5)			
RW <sub>w</sub> (n+6)			
RW <sub>w</sub> (n+7)			
RW <sub>w</sub> (n+8)			
RW <sub>w</sub> (n+9)			
RW <sub>w</sub> (n+A)			
RW <sub>w</sub> (n+B)			
RW <sub>w</sub> (n+C)			
RW <sub>w</sub> (n+D)			
RW <sub>w</sub> (n+E)			
RW <sub>w</sub> (n+F)			

Note: The occupied area means the area occupied depending on the setting of the number of remote device stations. For details on each allocation, refer to the pages describing the allocation.

Note: n indicates the register address of each station.

Example: When the station number is set to "01" and the number of stations is 1  
Master station buffer area

PLC address

Controller Serial No.	Address code	Remote input (RX)	Signal assignment	Remote output (RY)	Signal assignment
1	1	RX 00 to RX 0F	Domain	RY 00 to RY 0F	Domain
		RX 10 to RX 1F	System area	RY 10 to RY 1F	System area

Controller Serial No.	Address code	Data input		Data output	
		(RWr)	Data assignment	(RWw)	Data assignment
1	1	RWr 0	Domain	RWw 0	Domain
		RWr 1		RWw 1	
		RWr 2		RWw 2	
		RWr 3		RWw 3	

Example: When the station number is set to "01" and the number of stations is 2  
Master station buffer area

PLC address

Controller Serial No.	Address code	Remote input (RX)	Signal assignment	Remote output (RY)	Signal assignment
1	1	RX 00 to RX 0F	Domain	RY 00 to RY 0F	Domain
		RX 10 to RX 1F		RY 10 to RY 1F	
		RX 20 to RX 2F	System area	RY 20 to RY 2F	System area
		RX 30 to RX 3F		RY 30 to RY 3F	

Controller Serial No.	Address code	Data input		Data output	
		(RWr)	Data assignment	(RWw)	Data assignment
1	1	RWr 0	Domain	RWw 0	Domain
		RWr 1		RWw 1	
		RWr 2		RWw 2	
		RWr 3		RWw 3	
		RWr 4		RWw 4	
		RWr 5		RWw 5	
		RWr 6		RWw 6	
		RWr 7		RWw 7	

Example: When the station number is set to "01" and the number of stations is 4  
Master station buffer area

PLC address

Controller Serial No.	Address code	Remote input (RX)	Signal assignment	Remote output (RY)	Signal assignment
1	1	RX 00 to RX 0F	Domain	RY 00 to RY 0F	Domain
		RX 10 to RX 1F		RY 10 to RY 1F	
		RX 20 to RX 2F		RY 20 to RY 2F	
		RX 30 to RX 3F		RY 30 to RY 3F	
		RX 40 to RX 4F	System area	RY 40 to RY 4F	System area
		RX 50 to RX 5F		RY 50 to RY 5F	
		RX 60 to RX 6F		RY 60 to RY 6F	
		RX 70 to RX 7F		RY 70 to RY 7F	

Controller Serial No.	Address code	Data input		Data output	
		(RWr)	Data assignment	(RWw)	Data assignment
1	1	RWr 0	Domain	RWw 0	Domain
		RWr 1		RWw 1	
		RWr 2		RWw 2	
		RWr 3		RWw 3	
		RWr 4		RWw 4	
		RWr 5		RWw 5	
		RWr 6		RWw 6	
		RWr 7		RWw 7	
		RWr 8		RWw 8	
		RWr 9		RWw 9	
		RWr 10		RWw 10	
		RWr 11		RWw 11	
		RWr 12		RWw 12	
		RWr 13		RWw 13	
		RWr 14		RWw 14	
		RWr 15		RWw 15	

Example: When EW2C-H-CCD Serial No. 1 is used with the station number set to "01" and the number of stations set to 2, and EW2C-H-CCD Serial No. 2 is used with the station number set to "03" and the number of stations set to 1  
Master station buffer area

PLC address

Controller Serial No.	Address code	Remote input (RX)	Signal assignment	Remote output (RY)	Signal assignment
1	1	RX 00 to RX 0F	Domain	RY 00 to RY 0F	Domain
		RX 10 to RX 1F		RY 10 to RY 1F	
		RX 20 to RX 2F	System area	RY 20 to RY 2F	System area
		RX 30 to RX 3F		RY 30 to RY 3F	
2	3	RX 40 to RX 4F	Domain	RY 40 to RY 4F	Domain
		RX 50 to RX 5F	System area	RY 50 to RY 5F	System area

Controller Serial No.	Address code	Data input		Data output	
		(RWr)	Data assignment	(RWw)	Data assignment
1	1	RWr 0	Domain	RWw 0	Domain
		RWr 1		RWw 1	
		RWr 2		RWw 2	
		RWr 3		RWw 3	
		RWr 4		RWw 4	
		RWr 5		RWw 5	
		RWr 6		RWw 6	
2	3	RWr 7	Domain	RWw 7	Domain
		RWr 8		RWw 8	
		RWr 9		RWw 9	
		RWr 10		RWw 10	
		RWr 11		RWw 11	

\* Selecting two-station mode means using two station numbers. Therefore, if two-station mode is selected and the station number is set to "01," station number "02" becomes unavailable.

Example: When EW2C-H-CCD Serial No. 1 is used with the station number set to "01" and the number of stations set to 4, EW2C-H-CC Serial No. 2 is used with the station number set to "05," and EW2C-H-CCD Serial No. 3 is used with the station number set to "06" and the number of stations set to 1  
Master station buffer area

PLC address

Controller Serial No.	Address code	Remote input (RX)	Signal assignment	Remote output (RY)	Signal assignment
1	1	RX 00 to RX 0F	Domain	RY 00 to RY 0F	Domain
		RX 10 to RX 1F		RY 10 to RY 1F	
		RX 20 to RX 2F		RY 20 to RY 2F	
		RX 30 to RX 3F		RY 30 to RY 3F	
		RX 40 to RX 4F	System area	RY 40 to RY 4F	System area
		RX 50 to RX 5F		RY 50 to RY 5F	
		RX 60 to RX 6F		RY 60 to RY 6F	
		RX 70 to RX 7F		RY 70 to RY 7F	
2	5	RX 80 to RX 8F	Domain	RY 80 to RY 8F	Domain (unused)
		RX 90 to RX 9F	Domain (unused)	RY 90 to RY 9F	Domain
3	6	RX A0 to RX AF	Domain	RY A0 to RY AF	Domain
		RX B0 to RX BF	System area	RY B0 to RY BF	System area

Controller Serial No.	Address code	Data input		Data output	
		(RWr)	Data assignment	(RWw)	Data assignment
1	1	RWr 0	Domain	RWw 0	Domain
		RWr 1		RWw 1	
		RWr 2		RWw 2	
		RWr 3		RWw 3	
		RWr 4		RWw 4	
		RWr 5		RWw 5	
		RWr 6		RWw 6	
		RWr 7		RWw 7	
		RWr 8		RWw 8	
		RWr 9		RWw 9	
		RWr 10		RWw 10	
		RWr 11		RWw 11	
		RWr 12		RWw 12	
		RWr 13		RWw 13	
		RWr 14		RWw 14	
RWr 15	RWw 15				
3	6	RWr 16	Domain	RWw 16	Domain
		RWr 17		RWw 17	
		RWr 18		RWw 18	
		RWr 19		RWw 19	

\* Selecting four-station mode means using four station numbers. Therefore, if four-station mode is selected and the station number is set to "01," station numbers "02" to "04" become unavailable.  
\* Since no data is allocated for the remote I/O station (EW2C-H-CC), no occupancy information is provided in the data input/output table.

## 4-3-4-3-1 Lists of input/output signals and input/output data

Description of input signals

Code	Description	One-station occupancy	Two-station occupancy	Four-station occupancy
POS0	Point 0 bit setting	○	○	○
POS1	Point 1 bit setting	○	○	○
POS2	Point 2 bit setting	○	○	○
POS3	Point 3 bit setting	○	○	○
POS4	Point 4 bit setting	○	○	○
START	Start signal	○	○	○
STOP	Stop signal	○	○	○
ORG	Return to origin signal	○	○	○
X+	(+) movement by specified distance	○	○	○
X-	(-) movement by specified distance	○	○	○
XDEC	(-) movement at constant speed	x	○	○
XINC	(+) movement at constant speed	x	○	○
GMIN	Minimum sample pushing position setting	x	○	○
GMAX	Maximum sample pushing position setting	x	○	○
DR.START	Direct start signal	x	○	○
I.PNT	Point initialization	x	○	○
I.PRM	Parameter initialization	x	○	○
I.ERR	Error history initialization	x	○	○
R.PNT.ALL	Point data read (all)	x	x	○
R.PNT.MD	Point data read (mode)	x	○	x
R.PNT.POS	Point data read (position)	x	○	x
R.PNT.SPD	Point data read (speed)	x	○	x
R.PNT.LV	Point data read (pushing level)	x	○	x
R.PRM	Parameter read	x	○	○
R.VER	Version read	x	○	○
W.NP.POS	Current position write (point data)	○	○	○
W.NP.GMIN	Current position write (minimum sample pushing position)	x	○	○
W.NP.GMAX	Current position write (maximum sample pushing position)	x	○	○
W.NP.SFT	Current position write (origin shift position)	x	○	○
W.PNT.ALL	Point data write (all)	x	○	○
W.PNT.MD	Point data write (mode)	x	○	○
W.PNT.POS	Point data write (position)	x	○	○
W.PNT.SPD	Point data write (speed)	x	○	○
W.PNT.LV	Point data write (pushing level)	x	○	○
W.PRM	Writes parameters	x	○	○
W.CCS	Setting of the number of CC-Link stations	○	x	x
C.ERR	Current error output clear	○	○	○
C.DATA	Data output clear	x	○	○
D.PNT	Point data deletion	x	○	○

Description of output signals

Code	Description	1-address occupation	2-address occupation	4-address occupation
READY	Preparation completed output	○	○	○
BUSY	Command execution in progress output	○	○	○
INPOS	Positioning completed output	○	○	○
HOLD	Pushing completed output	○	○	○
O.ACT	Output while operating	○	○	○
O.WRITE	Output while writing	○	○	○
O.POS0	POS0 check signal output	x	○	○
O.POS1	POS1 check signal output	x	○	○
O.POS2	POS2 check signal output	x	○	○
O.POS3	POS3 check signal output	x	○	○
O.POS4	POS4 check signal output	x	○	○
O.START	START check signal output	x	○	○
O.STOP	STOP check signal output	x	○	○
O.ORG	ORG check signal output	x	○	○

Description of output data

Code	Description	1-address occupation	2-address occupation	4-address occupation
RD.NPL	Current position lower (x0.01 mm)	○	○	○
RD.NPU	Current position upper (x0.01 mm)	○	○	○
RD.CR	Motor current (mA)	○	○	○
RD.ERR	Current error	○	○	○
RD.MD	Mode data	x	△	○
RD.POSL	Lower position data (x0.01 mm)	x	△	○
RD.POSU	Upper position data (x0.01 mm)	x	△	○
RD.SPD	Speed data (mm/s)	x	△	○
RD.LV	Pushing level data	x	△	○
RD.PRM.DL	Parameter data lower/revision	x	△	○
RD.PRM.DU	Parameter data upper/version	x	△	○
RD.DL	Various data lower	x	○	△
RD.DU	Various data upper	x	○	△
RD.ERR.H01	History of past errors 1/0	x	○	○
RD.ERR.H23	History of past errors 3/2	x	○	○
RD.ERR.H45	History of past errors 5/4	x	x	○
RD.ERR.H67	History of past errors 7/6	x	x	○
RD.ERR.H89	History of past errors 9/8	x	x	○

\* When two-station mode is selected, the data of the items marked with a triangle (△) can be obtained individually.

\* When four-station mode is selected, a received data memory is provided individually, so no data items are listed.

Description of input data

Code	Description	One-station occupancy	Two-station occupancy	Four-station occupancy
WD.MD	Mode data	x	○	○
WD.POSL	Lower data of position (x0.01 mm)	x	○	○
WD.POSU	Upper data of position (x0.01 mm)	x	○	○
WD.SPD	Speed data (mm/s)	x	○	○
WD.LV	Pushing level data	x	○	○
WD.PRM.NO	Parameter No.	x	○	○
WD.PRM.DL	Parameter/actuator data, lower	x	○	○
WD.PRM.DU	Parameter/actuator data, upper	x	○	○
WD.CCS.NO	CC-Link station number	○	x	x

\* For details, refer to P. 27-40.

### 4-3-4-3-2 One-station mode (Remote device: One station occupied)

In this mode, the point data is specified first in the same way as when the point type or remote type is used.

The current position may be set as the point data.

Only basic data, such as the current position and current error information, can be obtained.

#### ○ PLC address configuration

<Controller => PLC>

PLC-side remote input (Controller => PLC)

Device No.	Code	Item	Value (decimal)
RX (n+0)0	READY	Preparation completed output	0: Alarm status, 1: Normal status
RX (n+0)1	BUSY	Command execution in progress output	1: Command being executed state
RX (n+0)2	INPOS	Positioning completed output	1: Positioning complete state
RX (n+0)3	HOLD	Pushing completed output	1: Pushing in progress
RX (n+0)4	O.ACT	Output while operating	0: Stopped, 1: Operating
RX (n+0)5	O.WRITE	Output while writing	1: Writing data
RX (n+0)6	-	Unused	
RX (n+0)7	-	Unused	
RX (n+0)8	-	Unused	
RX (n+0)9	-	Unused	
RX (n+0)A	-	Unused	
RX (n+0)B	-	Unused	
RX (n+0)C	-	Unused	
RX (n+0)D	-	Unused	
RX (n+0)E	-	Unused	
RX (n+0)F	-	Unused	

PLC-side remote register input (Controller => PLC)

Device No.	Code	Item	Value (decimal)
RWr (n+0)	RD.NPL	Current position lower (x0.01 mm)	-999999 - 999999
RWr (n+1)	RD.NPU	Current position upper (x0.01 mm)	RWr (n+0) indicate lower 16 bits, RWr (n+1) indicate upper 16 bits.
RWr (n+2)	RD.CR	Motor current (mA)	0 to 9999
RWr (n+3)	RD.ERR	Current error	0 to 99

<PLC => Controller>

PLC-side remote output (PLC => Controller)

Device No.	Code	Item	Value (decimal)
RY (n+0)0	POS0	Point 0 bit setting	Binary data Point Numbers 0 to 31  Note) See page 11
RY (n+0)1	POS1	Point 1 bit setting	
RY (n+0)2	POS2	Point 2 bit setting	
RY (n+0)3	POS3	Point 3 bit setting	
RY (n+0)4	POS4	Point 4 bit setting	
RY (n+0)5	START	Start signal	1: Starts
RY (n+0)6	STOP	Stop signal	0: Releases, 1: Stops
RY (n+0)7	ORG	Return to origin signal	1: Starts
RY (n+0)8	X+	(+) movement by specified distance	1: Starts
RY (n+0)9	X-	(-) movement by specified distance	1: Starts
RY (n+0)A	W.NP.POS	Write current position (point data)	1: Writes
RY (n+0)B	C.ERR	Clears current error output	1: Clears
RY (n+0)C	W.CCS	Setting of the number of CC-Link stations	1: Writes
RY (n+0)D	-	Unused	
RY (n+0)E	-	Unused	
RY (n+0)F	-	Unused	

PLC-side remote register output (PLC => Controller)

Device No.	Code	Item	Value (decimal)
RWw (n+0)	W.CCS	CC-Link station number	1: One station occupied, 2: Two stations occupied, 4: Four stations occupied
RWw (n+1)	-	Unused	-
RWw (n+2)	-	Unused	-
RWw (n+3)	-	Unused	-

#### 4-3-4-3-3 Two-station mode (Remote device: Two stations occupied)

In this mode, operation can be performed by specifying the position directly without using point data. You may specify the point data first for operation. In addition to the current position and current error information, point data, parameter data, and other data can be obtained. However, point data can be obtained for one item at a time. Therefore, to obtain point data for multiple items at a time, select four-station mode.

##### ○ PLC address configuration

<Controller => PLC>

PLC-side remote input (Controller => PLC)

Device No.	Code	Item	Value (decimal)
RX (n+0)0	READY	Preparation completed output	0: Alarm status, 1: Normal status
RX (n+0)1	BUSY	Command execution in progress output	1: Command being executed state
RX (n+0)2	INPOS	Positioning completed output	1: Positioning complete state
RX (n+0)3	HOLD	Pushing completed output	1: Pushing in progress
RX (n+0)4	O.ACT	Output while operating	0: Stopped, 1: Operating
RX (n+0)5	O.WRITE	Output while writing	1: Writing data
RX (n+0)6 - RX (n+0)F	-	Unused	
RX (n+1)0	O.POS0	POS0 check signal output	POS0 input status is output as is
RX (n+1)1	O.POS1	POS1 check signal output	POS1 input status is output as is
RX (n+1)2	O.POS2	POS2 check signal output	POS2 input status is output as is
RX (n+1)3	O.POS3	POS3 check signal output	POS3 input status is output as is
RX (n+1)4	O.POS4	POS4 check signal output	POS4 input status is output as is
RX (n+1)5	O.START	START check signal output	START input status is output as is
RX (n+1)6	O.STOP	STOP check signal output	STOP input status is output as is
RX (n+1)7	O.ORG	ORG check signal output	ORG input status is output as is
RX (n+1)8 - RX (n+1)F	-	Unused	

PLC-side remote register input (Controller => PLC)

Device No.	Code	Item	Value (decimal)						
RWr (n+0)	RD.NPL	Current position lower (x0.01 mm)	-999999 to 999999						
RWr (n+1)	RD.NPU	Current position upper (x0.01 mm)	RWr (n+0) indicate lower 16 bits, RWr (n+1) indicate upper 16 bits.						
RWr (n+2)	RD.CR	Motor current (mA)	0 to 9999						
RWr (n+3)	RD.ERR	Current error	0 to 99						
RWr (n+4)	RD.DL	Various data lower	The data that has been read is set. RWr (n+4) indicate lower 16 bits, RWr (n+5) indicate upper 16 bits. • For version information, RWr (n+5) indicates version information, and RWr (n+4) indicates revision information. • Speed data is shown in units of (x0.01 mm/s). • Position data is shown in units of (x0.01 mm).						
RWr (n+5)	RD.DU	Various data upper							
RWr (n+6)	RD.ERR.H01	History of past errors 1/0	Past alarm data histories are set. From the new order, then the lower 8 bits of RWr (n+6), and upper 8 bits of RWr (n+6). Register <table border="1" style="display: inline-table; vertical-align: middle;"> <tr> <td>RWr (n+6) Lower 8 bits</td> <td rowspan="4">New</td> </tr> <tr> <td>RWr (n+6) Upper 8 bits</td> </tr> <tr> <td>RWr (n+7) Lower 8 bits</td> </tr> <tr> <td>RWr (n+7) Upper 8 bits</td> <td>Old</td> </tr> </table>	RWr (n+6) Lower 8 bits	New	RWr (n+6) Upper 8 bits	RWr (n+7) Lower 8 bits	RWr (n+7) Upper 8 bits	Old
RWr (n+6) Lower 8 bits	New								
RWr (n+6) Upper 8 bits									
RWr (n+7) Lower 8 bits									
RWr (n+7) Upper 8 bits		Old							
RWr (n+7)	RD.ERR.H23	History of past errors 3/2							



&lt;PLC =&gt; Controller&gt;

PLC-side remote output (PLC =&gt; Controller)

Device No.	Code	Item	Value (decimal)
RY (n+0)0	POS0	Point 0 bit setting	Binary data Point Numbers 0 to 31  Note) See page 11
RY (n+0)1	POS1	Point 1 bit setting	
RY (n+0)2	POS2	Point 2 bit setting	
RY (n+0)3	POS3	Point 3 bit setting	
RY (n+0)4	POS4	Point 4 bit setting	
RY (n+0)5	START	Start signal	1: Starts
RY (n+0)6	STOP	Stop signal	0: Releases, 1: Stops
RY (n+0)7	ORG	Return to origin signal	1: Starts
RY (n+0)8	X+	(+) movement by specified distance	1: Starts
RY (n+0)9	X-	(-) movement by specified distance	1: Starts
RY (n+0)A	XDEC	(-) movement at constant speed	1: Starts
RY (n+0)B	XINC	(+) movement at constant speed	1: Starts
RY (n+0)C	GMIN	Minimum sample pushing position setting	1: Starts
RY (n+0)D	GMAX	Maximum sample pushing position setting	1: Starts
RY (n+0)E	DR.START	Direct start signal	1: Starts
RY (n+0)F	-	Unused	
RY (n+1)0	I.PNT	Point initialization	1: Starts initialization
RY (n+1)1	I.PRM	Parameter initialization	1: Starts initialization
RY (n+1)2	I.ERR	Initializes error history	1: Starts initialization
RY (n+1)3	R.PNT.MD	Reads points (mode)	1: Reads
RY (n+1)4	R.PNT.POS	Reads points (position)	1: Reads
RY (n+1)5	R.PNT.SPD	Reads points (speed)	1: Reads
RY (n+1)6	R.PNT.LV	Reads points (pushing level)	1: Reads
RY (n+1)7	R.PRM	Reads parameters	1: Reads
RY (n+1)8	R.VER	Reads versions	1: Reads
RY (n+1)9	-	Unused	
RY (n+1)F	-		
RY (n+2)0	W.NP.POS	Write current position (point data)	1: Writes
RY (n+2)1	W.NP.GMIN	Writes current position (minimum sample pushing position)	1: Writes
RY (n+2)2	W.NP.GMAX	Writes current position (maximum sample pushing position)	1: Writes
RY (n+2)3	W.NP.SFT	Writes current position (origin shift position)	1: Writes
RY (n+2)4	W.PNT.ALL	Writes points (all)	1: Writes
RY (n+2)5	W.PNT.MD	Writes points (mode)	1: Writes
RY (n+2)6	W.PNT.POS	Writes points (position)	1: Writes
RY (n+2)7	W.PNT.SPD	Writes points (speed)	1: Writes
RY (n+2)8	W.PNT.LV	Writes points (pushing level)	1: Writes
RY (n+2)9	W.PRM	Writes parameters	1: Writes
RY (n+2)A	C.ERR	Clears current error output	1: Clears
RY (n+2)B	C.DATA	Clears data output	1: Clears
RY (n+2)C	D.PNT	Deletes point	1: Deletes
RY (n+2)D	-	Unused	
RY (n+2)F	-		

PLC-side remote register output (PLC =&gt; Controller)

Device No.	Code	Item	Value (decimal)
RWw (n+0)	WD.MD	Mode data	65(A), 67(C), 73(I), 79(O), 85(U), 0(none/delete)
RWw (n+1)	WD.POSL	Lower position data (x0.01 mm)	-999999 - 999999
RWw (n+2)	WD.POSU	Upper position data (x0.01 mm)	RWw (n+1) indicate lower 16 bits, RWw (n+2) indicate upper 16 bits. Note) The input range varies depending on the model.
RWw (n+3)	WD.SPD	Speed data (mm/s)	0 to 30000 Note) The input range varies depending on the model.
RWw (n+4)	WD.LV	Pushing level data	0 to 5
RWw (n+5)	WD.PRM.NO	Parameter No.	0 to 300
RWw (n+6)	WD.PRM.DL	Parameter/actuator data lower	-999999 - 999999
RWw (n+7)	WD.PRM.DU	Parameter/actuator data upper	RWw (n+6) indicate lower 16 bits, RWw (n+7) indicate upper 16 bits. Note) The input range varies depending on the model.

#### 4-3-4-3-4 Four-station mode (Remote device: Four stations occupied)

In this mode, operation can be performed by specifying the position directly without using point data. You may specify the point data first for operation. You can set point data and initialize data. In addition to the current position and current error information, point data, parameter data, and other data can be obtained. The data that can be transmitted and received in this mode is the same as that in two-station mode, but this mode allows easier control of received data mainly because in this mode, for example, more error history records can be handled than in two-station mode.

##### ○ PLC address configuration

<Controller => PLC>

PLC-side remote input (Controller => PLC)

Device No.	Code	Item	Value (decimal)
RX (n+0)0	READY	Preparation completed output	0: Alarm status, 1: Normal status
RX (n+0)1	BUSY	Command execution in progress output	1: Command being executed state
RX (n+0)2	INPOS	Positioning completed output	1: Positioning complete state
RX (n+0)3	HOLD	Pushing completed output	1: Pushing in progress
RX (n+0)4	O.ACT	Output while operating	0: Stopped, 1: Operating
RX (n+0)5	O.WRITE	Output while writing	1: Writing data
RX (n+0)6 -	-	Unused	
RX (n+0)F			
RX (n+1)0	O.POS0	POS0 check signal output	POS0 input status is output as is
RX (n+1)1	O.POS1	POS1 check signal output	POS1 input status is output as is
RX (n+1)2	O.POS2	POS2 check signal output	POS2 input status is output as is
RX (n+1)3	O.POS3	POS3 check signal output	POS3 input status is output as is
RX (n+1)4	O.POS4	POS4 check signal output	POS4 input status is output as is
RX (n+1)5	O.START	START check signal output	START input status is output as is
RX (n+1)6	O.STOP	STOP check signal output	STOP input status is output as is
RX (n+1)7	O.ORG	ORG check signal output	ORG input status is output as is
RX (n+1)8 -	-	Unused	
RX (n+6)F			

PLC-side remote register input (Controller => PLC)

Device No.	Code	Item	Value (decimal)																	
RWr (n+0)	RD.NPL	Current position lower (x0.01 mm)	-999999 - 999999																	
RWr (n+1)	RD.NPU	Current position upper (x0.01 mm)	RWr (n+0) indicate lower 16 bits, RWr (n+1) indicate upper 16 bits.																	
RWr (n+2)	RD.CR	Motor current (mA)	0 to 9999																	
RWr (n+3)	RD.ERR	Current error	0 to 99																	
RWr (n+4)	RD.MD	Mode data	65(A), 67(C), 73(I), 79(O), 85(U), 0(none/delete)																	
RWr (n+5)	RD.POSL	Lower position data (x0.01 mm)	-999999 - 999999																	
RWr (n+6)	RD.POSU	Upper position data (x0.01 mm)	RWr (n+5) indicate lower 16 bits, RWr (n+6) indicate upper 16 bits.																	
RWr (n+7)	RD.SPD	Speed data (mm/s)	0 to 30000																	
RWr (n+8)	RD.LV	Pushing level data	0 to 5																	
RWr (n+9)	RD.PRM.DL	Parameter data lower/revision	The data that has been read is set. RWr (n+9) indicate lower 16 bits, RWr (n+A) indicate upper 16 bits.																	
RWr (n+A)	RD.PRM.DU	Parameter data upper/version	For version information, RWr (n+A) indicates version information, and RWr (n+9) indicates revision information.																	
RWr (n+B)	RD.ERR.H01	History of past errors 1/0	Past alarm data histories are set. From the new order, then the lower 8 bits of RWr (n+B), and upper 8 bits of RWr (n+B).																	
RWr (n+C)	RD.ERR.H23	History of past errors 3/2	<table border="1"> <thead> <tr> <th colspan="2">Register</th> </tr> </thead> <tbody> <tr> <td>RWr (n+B) Lower 8 bits</td> <td rowspan="2">New</td> </tr> <tr> <td>RWr (n+B) Upper 8 bits</td> </tr> <tr> <td>RWr (n+C) Lower 8 bits</td> <td rowspan="2"></td> </tr> <tr> <td>RWr (n+C) Upper 8 bits</td> </tr> <tr> <td>RWr (n+D) Lower 8 bits</td> <td rowspan="2"></td> </tr> <tr> <td>RWr (n+D) Upper 8 bits</td> </tr> <tr> <td>RWr (n+E) Lower 8 bits</td> <td rowspan="2"></td> </tr> <tr> <td>RWr (n+E) Upper 8 bits</td> </tr> <tr> <td>RWr (n+F) Lower 8 bits</td> <td rowspan="2">Old</td> </tr> <tr> <td>RWr (n+F) Upper 8 bits</td> </tr> </tbody> </table>	Register		RWr (n+B) Lower 8 bits	New	RWr (n+B) Upper 8 bits	RWr (n+C) Lower 8 bits		RWr (n+C) Upper 8 bits	RWr (n+D) Lower 8 bits		RWr (n+D) Upper 8 bits	RWr (n+E) Lower 8 bits		RWr (n+E) Upper 8 bits	RWr (n+F) Lower 8 bits	Old	RWr (n+F) Upper 8 bits
Register																				
RWr (n+B) Lower 8 bits	New																			
RWr (n+B) Upper 8 bits																				
RWr (n+C) Lower 8 bits																				
RWr (n+C) Upper 8 bits																				
RWr (n+D) Lower 8 bits																				
RWr (n+D) Upper 8 bits																				
RWr (n+E) Lower 8 bits																				
RWr (n+E) Upper 8 bits																				
RWr (n+F) Lower 8 bits	Old																			
RWr (n+F) Upper 8 bits																				
RWr (n+D)	RD.ERR.H45	History of past errors 5/4																		
RWr (n+E)	RD.ERR.H67	History of past errors 7/6																		
RWr (n+F)	RD.ERR.H89	History of past errors 9/8																		

## &lt;PLC =&gt; Controller&gt;

## PLC-side remote output (PLC =&gt; Controller)

Device No.	Code	Item	Value (decimal)
RY (n+0)0	POS0	Point 0 bit setting	Binary data Point Numbers 0 to 31  Note) See page 13
RY (n+0)1	POS1	Point 1 bit setting	
RY (n+0)2	POS2	Point 2 bit setting	
RY (n+0)3	POS3	Point 3 bit setting	
RY (n+0)4	POS4	Point 4 bit setting	
RY (n+0)5	START	Start signal	1: Starts
RY (n+0)6	STOP	Stop signal	0: Releases, 1: Stops
RY (n+0)7	ORG	Return to origin signal	1: Starts
RY (n+0)8	X+	(+) movement by specified distance	1: Starts
RY (n+0)9	X-	(-) movement by specified distance	1: Starts
RY (n+0)A	XDEC	(-) movement at constant speed	1: Starts
RY (n+0)B	XINC	(+) movement at constant speed	1: Starts
RY (n+0)C	GMIN	Minimum sample pushing position setting	1: Starts
RY (n+0)D	GMAX	Maximum sample pushing position setting	1: Starts
RY (n+0)E	DR.START	Direct start signal	1: Starts
RY (n+0)F	-	Unused	
RY (n+1)0	I.PNT	Point initialization	1: Starts initialization
RY (n+1)1	I.PRM	Parameter initialization	1: Starts initialization
RY (n+1)2	I.ERR	Initializes error history	1: Starts initialization
RY (n+1)3	R.PNT.ALL	Reads points (all)	1: Reads
RY (n+1)4	R.PRM	Reads parameters	1: Reads
RY (n+1)5	R.VER	Reads versions	1: Reads
RY (n+1)6 - RY (n+1)F	-	Unused	
RY (n+2)0	W.NP.POS	Write current position (point data)	1: Writes
RY (n+2)1	W.NP.GMIN	Writes current position (minimum sample pushing position)	1: Writes
RY (n+2)2	W.NP.GMAX	Writes current position (maximum sample pushing position)	1: Writes
RY (n+2)3	W.NP.SFT	Writes current position (origin shift position)	1: Writes
RY (n+2)4	W.PNT.ALL	Writes points (all)	1: Writes
RY (n+2)5	W.PNT.MD	Writes points (mode)	1: Writes
RY (n+2)6	W.PNT.POS	Writes points (position)	1: Writes
RY (n+2)7	W.PNT.SPD	Writes points (speed)	1: Writes
RY (n+2)8	W.PNT.LV	Writes points (pushing level)	1: Writes
RY (n+2)9	W.PRM	Writes parameters	1: Writes
RY (n+2)A	C.ERR	Clears current error output	1: Clears
RY (n+2)B	C.DATA	Clears data output	1: Clears
RY (n+2)C	D.PNT	Deletes point	1: Deletes
RY (n+2)D - RY (n+6)F	-	Unused	

## PLC-side remote register output (PLC =&gt; Controller)

Device No.	Code	Item	Value (decimal)
RWw (n+0)	WD.MD	Mode data	65(A), 67(C), 73(I), 79(O), 85(U), 0(none/delete)
RWw (n+1)	WD.POSL	Lower position data (x0.01 mm)	-999999 - 999999 RWw (n+1) indicate lower 16 bits, RWw (n+2) indicate upper 16 bits. Note) The input range varies depending on the model.
RWw (n+2)	WD.POSU	Upper position data (x0.01 mm)	
RWw (n+3)	WD.SPD	Speed data (mm/s)	
RWw (n+4)	WD.LV	Pushing level data	0 to 5
RWw (n+5)	WD.PRM.NO	Parameter No.	0 to 300
RWw (n+6)	WD.PRM.DL	Parameter/actuator data lower	-999999 - 999999 RWw (n+6) indicate lower 16 bits, RWw (n+7) indicate upper 16 bits. Note) The input range varies depending on the model.
RWw (n+7)	WD.PRM.DU	Parameter/actuator data upper	
RWw (n+8) - RWw (n+F)	-	Unused	

## 4-3-4-3-5 List of input data

○: Available ×: Unavailable

Code	Description	One-station occupancy	Two-station occupancy	Four-station occupancy
WD.MD	Mode data	×	○	○
WD.POSL	Lower data of position (x0.01 mm)	×	○	○
WD.POSU	Upper data of position (x0.01 mm)	×	○	○
WD.SPD	Speed data (mm/s)	×	○	○
WD.LV	Pushing level data	×	○	○
WD.PRM.NO	Parameter No.	×	○	○
WD.PRM.DL	Parameter/actuator data, lower	×	○	○
WD.PRM.DU	Parameter/actuator data, upper	×	○	○
WD.CCS.NO	CC-Link station number	○	×	×

## 4-3-4-3-6 Details of input data

## (1) WD.MD

Function Set this when specifying mode.

Data format

Data name	WD.MD
Data position	16bit

Example: For mode A

Data name	WD.MD
Data position	65 (hexadecimal: 41) Character: A

ASCII control character

Mode name	A	I	C	O	U
Decimal data	65	73	67	79	85
Hexadecimal data	41	49	43	4F	55

Input by ASCII control character.

## (2) WD.POSU, WD.POSL

Function Set this when specifying the position. Unit: (x0.01 mm)

Data format

Data name	WD.POSU	WD.POSL
Data position	Upper 16 bits	Lower 16 bits
	Total 32 bits	

Example: For position -5.00

Data name	WD.POSU	WD.POSL
Data position	65535 (hexadecimal: FFFF)	65035 (hexadecimal: FE0C)
	-500 (hexadecimal: FFFF0C)	

Example: For position 1000.15 mm

Data name	WD.POSU	WD.POSL
Data position	1 (hexadecimal: 1)	34479 (hexadecimal: 86AF)
	100015 (hexadecimal: 186AF)	

**(3) WD.SPD**

Function Set this when specifying the speed. Unit: (mm/s)

Data format

Data name	WD.SPD
Data position	16bit

Example: For 50 mm/s

Data name	WD.SPD
Data position	50 (hexadecimal: 32)

**(4) WD.LV**

Function Set this when specifying the pushing level.

Data format

Data name	WD.LV
Data position	16bit

Example: For level 5

Data name	WD.LV
Data position	5 (hexadecimal: 5)

**(5) WD.PRM.NO**

Function Set this when specifying the parameter number.

Data format

Data name	WD.PRM.NO
Data position	16bit

Example: For PRM10

Data name	WD.PRM.NO
Data position	10 (hexadecimal: A)

**(6) WD.PRM.DU, WD.PRM.DL**

Function Set this when specifying the parameter data. Also, set this when specifying the actuator number.

Data format

Data name	WD.PRM.DU	WD.PRM.DL
Data position	Upper 16 bits	Lower 16 bits
	Total 32 bits	

Example: For data -1600

Data name	WD.PRM.DU	WD.PRM.DL
Data position	65535 (hexadecimal: FFFF)	63935 (hexadecimal: F9C0)
	-1600 (hexadecimal: FFFF9C0)	

Example: For data 160000

Data name	WD.PRM.DU	WD.PRM.DL
Data position	2 (hexadecimal: 2)	28928 (hexadecimal: 7100)
	160000 (hexadecimal: 27100)	

Example: For EW2G12H-80 actuator number 28

Data name	WD.PRM.DU	WD.PRM.DL
Data position	0	28 (hexadecimal: 1C)
	28 (hexadecimal: 1C)	

**(7) WD.CCS.NO**

Function Set this when specifying the number of stations occupied in one-station mode.

Data format

Data name	WD.CCS.NO
Data position	16bit

## 4-3-4-3-7 List of input signals

○: Available ×: Unavailable

Code	Description	1-address occupation	2-address occupation	4-address occupation
POS0	Point 0 bit setting	○	○	○
POS1	Point 1 bit setting	○	○	○
POS2	Point 2 bit setting	○	○	○
POS3	Point 3 bit setting	○	○	○
POS4	Point 4 bit setting	○	○	○
START	Start signal	○	○	○
STOP	Stop signal	○	○	○
ORG	Return to origin signal	○	○	○
X+	(+) movement by specified distance	○	○	○
X-	(-) movement by specified distance	○	○	○
XDEC	(-) movement at constant speed	×	○	○
XINC	(+) movement at constant speed	×	○	○
GMIN	Minimum sample pushing position setting	×	○	○
GMAX	Maximum sample pushing position setting	×	○	○
DR.START	Direct start signal	×	○	○
I.PNT	Point initialization	×	○	○
I.PRM	Parameter initialization	×	○	○
I.ERR	Initializes error history	×	○	○
R.PNT.ALL	Reads points (all)	×	×	○
R.PNT.MD	Reads points (mode)	×	○	×
R.PNT.POS	Reads points (position)	×	○	×
R.PNT.SPD	Reads points (speed)	×	○	×
R.PNT.LV	Reads points (pushing level)	×	○	×
R.PRM	Reads parameters	×	○	○
R.VER	Reads versions	×	○	○
W.NP.POS	Write current position (point data)	○	○	○
W.NP.GMIN	Writes current position (minimum sample pushing position)	×	○	○
W.NP.GMAX	Writes current position (maximum sample pushing position)	×	○	○
W.NP.SFT	Writes current position (origin shift position)	×	○	○
W.PNT.ALL	Writes points (all)	×	○	○
W.PNT.MD	Writes points (mode)	×	○	○
W.PNT.POS	Writes points (position)	×	○	○
W.PNT.SPD	Writes points (speed)	×	○	○
W.PNT.LV	Writes points (pushing level)	×	○	○
W.PRM	Writes parameters	×	○	○
C.ERR	Clears current error output	○	○	○
C.DATA	Clears data output	×	○	○
D.PNT	Deletes point	×	○	○

## 4-3-4-3-8 Details of input signals

## (1) POS0 - POS4

Function Sets the point number. For the bit point number, refer to P. 13.  
Signal ON: Bit ON OFF: Bit OFF

## (2) START

Function Executes operation based on the point data of the point number specified in POS0 to POS4.  
Signal ON: Starts operation.  
Remarks If operation does not start, check the error number and point data.

## (3) STOP

Function Stops operation.  
Signal ON: Stops operation.  
Remarks While the STOP signal is being input, no operation starts even if an operation command is input.

## (4) ORG

Function Executes return to origin.  
Signal ON: Starts return to origin.

## (5) X+ / X-

Function Moves by only the specified distance at the speed shown below.  
Movement distance = PRM25/100 [mm]  
Moving speed = PRM24 [mm/s]  
Movement direction X+: (+) side X-: (-) side  
Signal ON: Starts movement by the specified distance.

## (6) XINC / XDEC

Function Performs pushing operation at the speed shown in the following equation.  
The tooling stops moving when the stop command is input, the pushed object is detected, or the tooling reaches the software limit.  
Moving speed = PRM24 [mm/s]  
Pushing level = PRM26  
Movement direction XINC: (+) side XDEC: (-) side  
Signal ON: Starts pushing operation.

## (7) GMIN / GMAX

Function Sets the pushing position for the minimum sample (maximum sample) when using the size detecting function.  
Pushing direction WD.MD data O: (+) side C: (-) side  
Moving speed WD.SPD data  
Pushing level WD.LV data  
Set sample GMIN: Minimum sample GMAX: Maximum sample  
Signal ON: Starts size detection operation.  
Remarks The pushing position is stored in PRM32 (minimum sample pushing position) for GMIN or PRM31 (maximum sample pushing position) for GMAX.

## (8) DR.START

Function Specifies operation directly. See "4-5 Point data specifications" for the input range.  
Mode WD.MD data  
Movement position WD.POSU data, WD.POSL data  
Moving speed WD.SPD data  
Pushing level WD.LV data  
Signal ON: Starts direct operation.



## (9) I.PNT

Function Deletes all point data.  
Signal ON: Executes point data deletion.

## (10) I.PRM

Function Resets parameter data to their initial values.  
Actuator No. WD.PRM.DU data, WD.PRM.DL data  
Signal ON: Executes initialization.  
Remarks The first 2 digits of the serial No. on the actuator unit are the actuator No.  
Check the actuator No. on the actuator unit, and then initialize the parameters.

Model	EW2G10□ S-10	EW2G10□ S-30	EW2G10□ S-50	EW2G10□ H-10	EW2G10□ H-30	EW2G10□ H-50		
Actuator No.	10	11	12	15	16	17		
Model	EW2G12□ S-20	EW2G12□ S-40	EW2G12□ S-60	EW2G12□ S-80	EW2G12□ H-20	EW2G12□ H-40	EW2G12□ H-60	EW2G12□ H-80
Actuator No.	20	21	22	23	25	26	27	28
Model	EW2G16□ S-20	EW2G16□ S-40	EW2G16□ S-60	EW2G16□ S-100	EW2G16□ H-20	EW2G16□ H-40	EW2G16□ H-60	EW2G16□ H-100
Actuator No.	30	31	32	33	35	36	37	38

## (11) I.ERR

Function Deletes all error history data.  
Signal ON: Executes initialization.

## (12) R.PNT.ALL

Function Reads all the point data of the point number specified in POS0 to POS4 at a time.  
Mode RD.MD data  
Movement position RD.POSU data, RD.POSL data  
Moving speed RD.SPD data  
Pushing level RD.LV data  
Signal ON: Executes read operation.

## (13) R.PNT.MD

Function Reads the mode in the point data of the point number specified in POS0 to POS4.  
Mode RD.DU data, RD.DL data  
Signal ON: Executes read operation.

## (14) R.PNT.POS

Function Reads the movement position in the point data of the point number specified in POS0 to POS4.  
Movement position RD.DU data, RD.DL data  
Signal ON: Executes read operation.

## (15) R.PNT.SPD

Function Reads the moving speed in the point data of the point number specified in POS0 to POS4.  
Moving speed RD.DU data, RD.DL data  
Signal ON: Executes read operation.

## (16) R.PNT.LV

Function Reads the pushing level in the point data of the point number specified in POS0 to POS4.  
Pushing level RD.DU data, RD.DL data  
Signal ON: Executes read operation.

## (17) R.PRM

Function Reads parameters.  
Specified parameter No. WD.PRM.NO data  
Data to be read (when two stations are occupied) RD.DU data, RD.DL data  
Data to be read (when four stations are occupied) RD.PRM.DU data, RD.PRM.DL data  
Signal ON: Executes read operation.

## (18) R.VER

Function Reads the controller software version number.  
 Data to be read (when two stations are occupied) RD.DU data, RD.DL data  
 Data to be read (when four stations are occupied) RD.PRM.DU data, RD.PRM.DL data  
 Signal ON: Executes read operation.  
 Remarks The version data and revision data are stored in DU and DL, respectively.

## (19) W.NP.POS

Function Writes the current position in the point data of the point number specified in POS0 to POS4.  
 Signal ON: Executes write operation.  
 Remarks Write is possible even when the point data is O mode or C mode but the written information is not reflected in O and C mode operation.  
 Remarks If no O.WRITE signal is output, check the error number and point data.  
 Even without any output, the write may have been completed normally depending mainly on the number of units connected and transmission rate.

## (20) W.NP.GMIN / W.NP.GMAX

Function Sets the current position as the pushing position for the minimum sample (maximum sample) when using the size detecting function.  
 Set sample W.NP.GMIN: Minimum sample W.NP.GMAX: Maximum sample  
 Signal ON: Executes write operation.  
 Remarks The current position is stored in PRM32 (minimum sample pushing position) for W.NP.GMIN or PRM31 (maximum sample pushing position) for W.NP.GMAX.  
 Remarks If no O.WRITE signal is output, check the error number and point data.  
 Even without any output, the write may have been completed normally depending mainly on the number of units connected and transmission rate.

## (21) W.NP.SFT

Function Sets the current position as the origin shift distance (virtual origin).  
 Signal ON: Executes write operation.  
 Remarks For W.NP.SFT, the current position is stored in PRM35 (origin shift distance).  
 Remarks If no O.WRITE signal is output, check the error number and point data.  
 Even without any output, the write may have been completed normally depending mainly on the number of units connected and transmission rate.

## (22) W.PNT.ALL

Function Writes all the point data of the point number specified in POS0 to POS4 at a time.  
 Mode WD.MD data  
 Movement position WD.POSU data, WD.POSL data  
 Moving speed WD.SPD data  
 Pushing level WD.LV data  
 Signal ON: Executes write operation.  
 Remarks If no O.WRITE signal is output, check the error number and point data.  
 Even without any output, the write may have been completed normally depending mainly on the number of units connected and transmission rate.

## (23) W.PNT.MD

Function Writes the mode in the point data of the point number specified in POS0 to POS4.  
 Mode WD.MD data  
 Signal ON: Executes write operation.  
 Remarks If no O.WRITE signal is output, check the error number and point data.  
 Even without any output, the write may have been completed normally depending mainly on the number of units connected and transmission rate.

## (24) W.PNT.POS

Function Writes the movement position in the point data of the point number specified in POS0 to POS4.  
 Movement position WD.POSU data, WD.POSL data  
 Signal ON: Executes write operation.  
 Remarks If no O.WRITE signal is output, check the error number and point data.  
 Even without any output, the write may have been completed normally depending mainly on the number of units connected and transmission rate.

## (25) W.PNT.SPD

Function Writes the moving speed in the point data of the point number specified in POS0 to POS4.  
 Moving speed WD.SPD data  
 Signal ON: Executes write operation.  
 Remarks If no O.WRITE signal is output, check the error number and point data.  
 Even without any output, the write may have been completed normally depending mainly on the number of units connected and transmission rate.

## (26) W.PNT.LV

Function Writes the pushing level in the point data of the point number specified in POS0 to POS4.  
 Pushing level WD.LV data  
 Signal ON: Executes write operation.  
 Remarks If no O.WRITE signal is output, check the error number and point data.  
 Even without any output, the write may have been completed normally depending mainly on the number of units connected and transmission rate.

## (27) W.PRM

Function Writes parameters.  
 Specified parameter No. WD.PRM.NO data  
 Data to be written WD.PRM.DU data, WD.PRM.DL data  
 Signal ON: Executes write operation.  
 Remarks If no O.WRITE signal is output, check the error number and point data.  
 Even without any output, the write may have been completed normally depending mainly on the number of units connected and transmission rate.  
 Note: PRM0 indicates the actuator number, so cannot be changed by writing parameters.  
 Change it by initializing parameters.

## (28) W.CCS

Function Sets the number of stations occupied.  
 Specified number of stations WD.CCS.NO data  
 Signal ON: Executes write operation.

## (29) C.ERR

Function Clears the current error output data.  
 Current error output RD.ERR data  
 Signal ON: Clears data.  
 Remarks This function is not used to clear alarms, such as overtimes, but is used to clear only the output values.

## (30) C.DATA

Function Clears output data other than the current errors.  
 (Data to be cleared when two stations are occupied)  
 RD.DU data, RD.DL data  
 (Data to be cleared when four stations are occupied)  
 RD.MD data, RD.POSU data, RD.POSL data, RD.SPD data,  
 RD.LV data, RD.PRM.DU data, RD.PRM.DL data  
 Signal ON: Clears data.

## (31) D.PNT

Function Deletes the point data of the point number specified in POS0 to POS4.  
 Signal ON: Executes deletion.  
 Remarks If no O.WRITE signal is output, check the error number and point data.  
 Even without any output, the write may have been completed normally depending mainly on the number of units connected and transmission rate.

## 4-3-4-3-9 List of output data

○: Available △: Covered by another data ×: Unavailable

Code	Description	1-address occupation	2-address occupation	4-address occupation
RD.NPL	Current position lower (x0.01 mm)	○	○	○
RD.NPU	Current position upper (x0.01 mm)	○	○	○
RD.CR	Motor current (mA)	○	○	○
RD.ERR	Current error	○	○	○
RD.MD	Mode data	×	△	○
RD.POSL	Lower position data (x0.01 mm)	×	△	○
RD.POSU	Upper position data (x0.01 mm)	×	△	○
RD.SPD	Speed data (mm/s)	×	△	○
RD.LV	Pushing level data	×	△	○
RD.PRM.DL	Parameter data lower/revision	×	△	○
RD.PRM.DU	Parameter data upper/version	×	△	○
RD.DL	Various data lower	×	○	△
RD.DU	Various data upper	×	○	△
RD.ERR.H01	History of past errors 1/0	×	○	○
RD.ERR.H23	History of past errors 3/2	×	○	○
RD.ERR.H45	History of past errors 5/4	×	×	○
RD.ERR.H67	History of past errors 7/6	×	×	○
RD.ERR.H89	History of past errors 9/8	×	×	○

\* When two-station mode is selected, the data of the items marked with a triangle (△) can be obtained individually.

\* When four-station mode is selected, a received data memory is provided individually, so no data items are listed.

## 4-3-4-3-10 Details of output data

## (1) RD.NPU, RD.NPL

Function Stores the current position when obtained. Unit: (x0.01 mm)

Data format

Data name	RD.NPU	RD.NPL
Data position	Upper 16 bits	Lower 16 bits
	Total 32 bits	

Example: For position -5.00

Data name	RD.NPU	RD.NPL
Data position	65535 (hexadecimal: FFFF)	65035 (hexadecimal: FE0C)
	-500 (hexadecimal: FFFFFE0C)	

Example: For position 1000.15 mm

Data name	RD.NPU	RD.NPL
Data position	1 (hexadecimal: 1)	34479 (hexadecimal: 86AF)
	100015 (hexadecimal: 186AF)	

## (2) RD.CR

Function Stores the average current flowing in the motor when obtained. Unit: (mA)

Data format

Data name	RD.CR
Data position	16bit

Example: For 1000 mA

Data name	RD.CR
Data position	1000 (hexadecimal: 3E8)

## (3) RD.ERR

Function Stores the current error when obtained.

After an error occurs, it can be cleared by inputting the return to origin or C.ERR signal.

Data format

Data name	RD.ERR
Data position	16bit

Example: For 01. Overtime occurs

Data name	RD.ERR
Data position	1 (hexadecimal: 1)

Example: If there is no error

Data name	RD.ERR
Data position	0

## (4) RD.MD

Function Stores the mode data in the point data when obtained.

Data format

Data name	RD.MD
Data position	16bit

Example: For mode A

Data name	RD.MD
Data position	65 (hexadecimal: 41)
	Character: A

ASCII control character

Mode name	A	I	C	O	U
Decimal data	65	73	67	79	85
Hexadecimal data	41	49	43	4F	55

## (5) RD.POSU, RD.POSL

Function Stores the position data in the point data when obtained. Unit: (x0.01 mm)

Data format

Data name	RD.NPU	RD.NPL
Data position	Upper 16 bits	Lower 16 bits
	Total 32 bits	

Example: For position -5.00 mm

Data name	RD.NPU	RD.NPL
Data position	65535 (hexadecimal: FFFF)	65035 (hexadecimal: FE0C)
	-500 (hexadecimal: FFFFFE0C)	

Example: For position 1000.15 mm

Data name	RD.NPU	RD.NPL
Data position	1 (hexadecimal: 1)	34479 (hexadecimal: 86AF)
	100015 (hexadecimal: 186AF)	

## (6) RD.SPD

Function Stores the speed data in the point data when obtained. Unit: (mm/s)

Data format

Example: For mode A

Data name	RD.MD
Data position	65 (hexadecimal: 41)
	Character: A

Data name	RD.SPD
Data position	16bit

## (7) RD.LV

Function Stores the pushing level data in the point data when obtained.

Data format

Data name	RD.LV
Data position	16bit

Example: For level 5

Data name	RD.LV
Data position	5 (hexadecimal: 5)

## (8) RD.PRM.DU, RD.PRM.DL

**Function** Stores the parameter data and actuator number when obtained.

In addition, when version information is obtained, the version data and revision data are stored in the first 16 bits and last 16 bits, respectively.

**Data format**

Data name	RD.PRM.DU	RD.PRM.DL
Data position	Upper 16 bits	Lower 16 bits
	Total 32 bits	

**Example: For data -1600**

Data name	RD.PRM.DU	RD.PRM.DL
Data position	65535 (hexadecimal: FFFF)	63935 (hexadecimal: F9C0)
	-1600 (hexadecimal: FFFFF9C0)	

**Example: For data 160000**

Data name	RD.PRM.DU	RD.PRM.DL
Data position	2 (hexadecimal: 2)	28928 (hexadecimal: 7100)
	160000 (hexadecimal: 27100)	

**Example: For EW2G12H-80 actuator number 28**

Data name	RD.PRM.DU	RD.PRM.DL
Data position	0	28 (hexadecimal: 1C)
	28 (hexadecimal: 1C)	

**Example: For version 1.00**

Data name	RD.PRM.DU	RD.PRM.DL
Data position	100 (hexadecimal: 64)	0
	6553600 (hexadecimal: 640000)	

**Example: For version 1.80a**

Data name	RD.PRM.DU	RD.PRM.DL
Data position	180 (hexadecimal: B4)	1 (hexadecimal: 1)
	11796481 (hexadecimal: B40001)	

## (9) RD.DU, RD.DL

Function Stores data in the point data, parameter data, and actuator number when obtained.  
In addition, when version information is obtained, the version data and revision data are stored in the first 16 bits and last 16 bits, respectively.

Data format

Data name	RD.DU	RD.DL
Data position	Upper 16 bits	Lower 16 bits
	Total 32 bits	

Example: For data -1600

Data name	RD.DU	RD.DL
Data position	65535 (hexadecimal: FFFF)	63935 (hexadecimal: F9C0)
	-1600 (hexadecimal: FFFF9C0)	

Example: For data 160000

Data name	RD.DU	RD.DL
Data position	2 (hexadecimal: 2)	28928 (hexadecimal: 7100)
	160000 (hexadecimal: 27100)	

Example: For mode A

Data name	RD.DU	RD.DL
Data position	0	65 (hexadecimal: 41)
	Character: A	

Example: For EW2G16S-20 actuator number 30

Data name	RD.DU	RD.DL
Data position	0	30 (hexadecimal: 1E)
	30 (hexadecimal: 1E)	

Example: For version 1.00

Data name	RD.DU	RD.DL
Data position	100 (hexadecimal: 64)	0
	6553600 (hexadecimal: 640000)	

Example: For version 1.80a

Data name	RD.DU	RD.DL
Data position	180 (hexadecimal: B4)	1 (hexadecimal: 1)Note
	11796481 (hexadecimal: B40001)	

Note: Version information is stored after converted, for example, from a to 1, from b to 2, and from c to 3.



## (10) RD.ERR.H01 - RD.ERR.H89

Function Stores past error history. In addition, when version information is obtained, the version data and revision data are stored in the first 16 bits and last 16 bits, respectively.

Data format

Data name	RD.ERR.H01	
Data position	Upper 8 bits	Lower 8 bits
	History 1	History 0 (latest)
	Total 16 bits	

Data name	RD.ERR.H23	
Data position	Upper 8 bits	Lower 8 bits
	History 3	History 2
	Total 16 bits	

. . .

RD.ERR.H45 and past history.

Example:

If occurs in order from newest: 01, 21, 23, 06, 31, 32, 31, 32, 23, 01

Data name	RD.ERR.H01	
Data position	Upper 8 bits	Lower 8 bits
	21 (hexadecimal: 15)	1 (hexadecimal: 1)
	5377 (hexadecimal: 1501)	

Data name	RD.ERR.H23	
Data position	Upper 8 bits	Lower 8 bits
	6 (hexadecimal: 6)	23 (hexadecimal: 17)
	1559 (hexadecimal: 617)	

Data name	RD.ERR.H45	
Data position	Upper 8 bits	Lower 8 bits
	32 (hexadecimal: 20)	31 (hexadecimal: 1F)
	8223 (hexadecimal: 201F)	

Data name	RD.ERR.H67	
Data position	Upper 8 bits	Lower 8 bits
	32 (hexadecimal: 20)	31 (hexadecimal: 1F)
	8223 (hexadecimal: 201F)	

Data name	RD.ERR.H89	
Data position	Upper 8 bits	Lower 8 bits
	1 (hexadecimal: 1)	23 (hexadecimal: 17)
	279 (hexadecimal: 117)	

Remarks: When two stations are occupied, RD.ERR.H45 and subsequent data cannot be obtained.

## 4-3-4-3-11 List of output signals

○: Available x: Unavailable

Code	Description	1-address occupation	2-address occupation	4-address occupation
READY	Preparation completed output	○	○	○
BUSY	Command execution in progress output	○	○	○
INPOS	Positioning completed output	○	○	○
HOLD	Pushing completed output	○	○	○
O.ACT	Output while operating	○	○	○
O.WRITE	Output while writing	○	○	○
O.POS0	POS0 check signal output	x	○	○
O.POS1	POS1 check signal output	x	○	○
O.POS2	POS2 check signal output	x	○	○
O.POS3	POS3 check signal output	x	○	○
O.POS4	POS4 check signal output	x	○	○
O.START	START check signal output	x	○	○
O.STOP	STOP check signal output	x	○	○
O.ORG	ORG check signal output	x	○	○

## 4-3-4-3-12 Details of output signals

## (1) READY

Function Preparation completed output. When the controller system is operating normally, this output is set to ON.

If an alarm is issued, this output is set to OFF and the motor enters a free state.

Signal ON: Normal OFF: Alarm generated

## (2) BUSY

Function Command execution in progress output. This signal is set to ON when a dedicated command input is being executed or when a command from a personal computer is being executed. When the BUSY signal is ON, no operation, except return to origin, is accepted.

Signal ON: Command execution in progress OFF: Possible to accept commands

Caution: Always turn off dedicated command inputs when BUSY is ON. Leaving input ON prevents BUSY from switching to OFF, even after completing execution of a command.

## (3) INPOS

Function Positioning operation completed output.

This signal turns OFF whenever a dedicated command input is accepted, and then turns ON when the positioning operation execution process is completed normally, or when the size detecting function is set. If an error occurs during execution, or if STOP has been input, the signal remains unchanged in the OFF state.

Signal ON: After return to origin operation is completed, positioning operation is completed normally, the size detecting function is set, and the size is within the set range.  
OFF: Other than the above.

## (4) HOLD

Function Pushing operation completed output. This signal turns OFF whenever a dedicated command input is accepted, and then turns ON when the pushing operation execution process is completed normally.

If an error occurs during execution, or if STOP has been input, the signal remains unchanged in the OFF state.

Signal ON: Pushing operation completed normally (pushed object detected)  
OFF: Pushed object not detected

## (5) O.ACT

Function Actuator operation in progress output Unlike the BUSY signal, this signal is not related to dedicated command input signals.  
This signal is OFF while the HOLD signal is ON.

Signal ON: Actuator operating OFF: Actuator stopped

## (6) O.WRITE

Function Storage medium write in progress output. This signal is output when point data or parameter data is written or initialized. While this signal is being output, no commands, including write commands via CC-Link, are accepted.  
In addition, this signal is not output when history data is written due to the occurrence of an error. Some write commands are completed instantly.  
This output may not be detected depending on the number of units connected and transmission rate. When the write is executed, check the error number and point data to see whether the write is completed normally.

Signal ON: Storage medium write in progress OFF: Waiting for data to be written

## (7) O.POS0 - O.POS4, O.START, O.STOP, O.ORG

Function Dedicated input check output. When the POS0 to POS4, START, STOP, or ORG signal is input, it is returned as it is, as an output. Use this to check that each signal is input normally.

Signal ON: Dedicated input signal input OFF: Dedicated input signal not input

### 4-3-5 Timing chart

(1) When the power is turned on

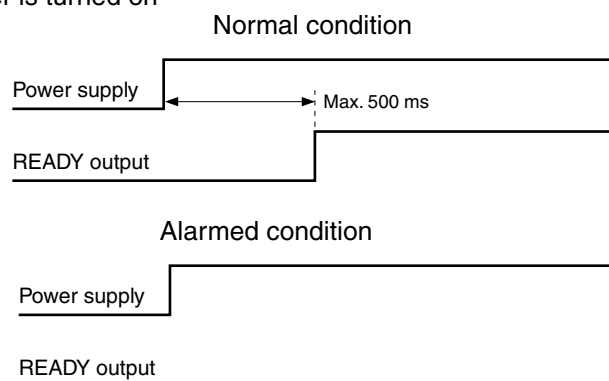

Before inputting a dedicated command, check that the READY output is turned ON after the power has been supplied.

If READY output is OFF, even after the specified time has elapsed after the power is turned on, it means that an alarm has occurred.

#### 4-3-5-1 Timing charts for EW2C-H-NP, EW2C-H-PN, and EW2C-H-CC

(1) Execution of custom command

- When a dedicated command is received, the BUSY output turns ON. Whether the BUSY output turns off determines whether the command has ended normally.
- Always use pulse inputs for dedicated commands. Leaving input ON prevents BUSY output from turning OFF even after execution of a command has been completed.

1. When returning to origin

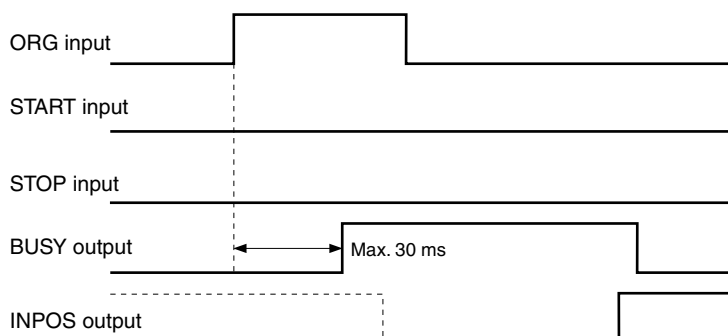

- ① After ORG input is turned ON, the BUSY output is turned ON.
- ② After confirming that BUSY output has turned ON, the ORG input is turned OFF (contact is opened).
- ③ Waits until BUSY output is turned OFF.
- ④ When BUSY output is turned OFF, INPOS output is ON, and this means that the operation has ended normally.

1-1. When returning to origin (w/ origin shift)

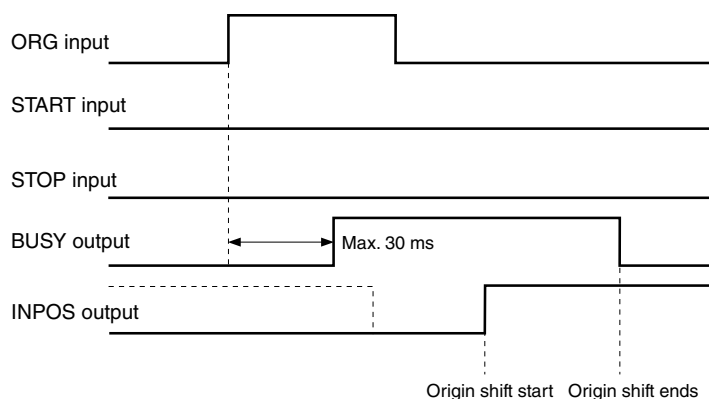

## 2. Positioning mode, for A, I

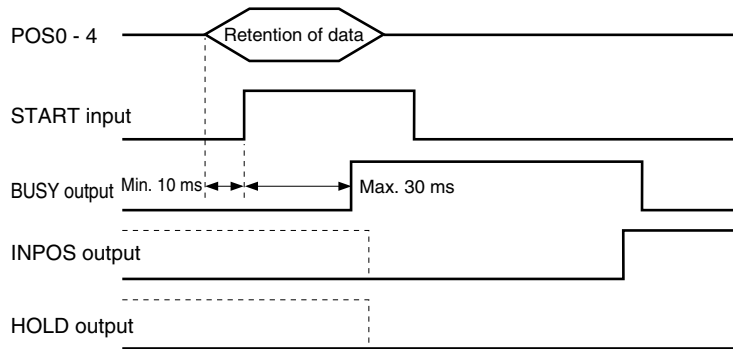

- ① Input the point No. in POS0 to POS4. Maintain this input state until BUSY output turns ON.  
(Changing the input state too early could cause mis-recognition of data.)
- ② Introduce a delay of at least 10 ms, and then input START input.
- ③ At the rise of a dedicated command input, BUSY output turns ON.
- ④ Check that BUSY output is ON, and then set the dedicated command input to OFF (open the contact).  
After this, the point data can be freely changed.
- ⑤ Wait until BUSY output turns OFF.
- ⑥ When BUSY output turns OFF, INPOS output is ON, and this means that the operation has ended normally.

## 3. Pushing mode, for U, C, O

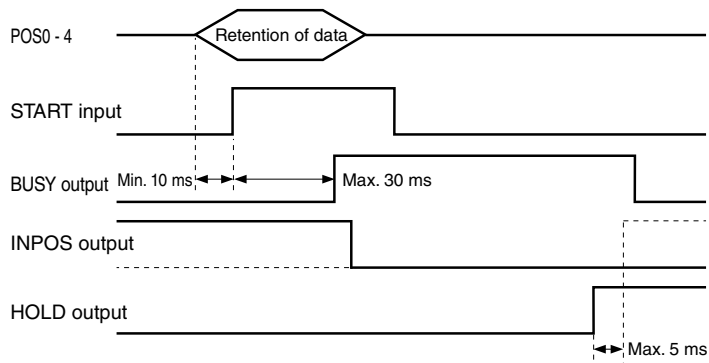

- ① Input the point No. in POS0 to POS4. Maintain this input state until BUSY output turns ON.  
(Changing the input state too early could cause mis-recognition of data.)
  - ② Introduce a delay of at least 10 ms, and then input START input.
  - ③ At the rise of a dedicated command input, BUSY output turns ON.
  - ④ Check that BUSY output is ON, and then set the dedicated command input to OFF (open the contact).  
After this, the point data can be freely changed.
  - ⑤ Wait until BUSY output turns OFF.
  - ⑥ When BUSY output turns OFF, HOLD output is ON, and this means that the operation has ended normally.
- \* If no pushed object is detected, the tooling stops at the limit position. At this time, INPOS output and HOLD output turn OFF.
- \* When the workpiece is pushed within the set range with the size detecting function enabled, HOLD output turns ON, and then INPOS output turns ON within 5 ms.

### 4-3-5-2 Timing charts for EW2C-H-CCD

The communication delay time differs depending on the number of units connected and transmission rate. The wait time is longer than stated here because there is a communication delay time. Control must take account of communication delays.

#### (1) When an operation command is executed

- When an operation command is received, the BUSY output turns ON. Whether the BUSY output turns off determines whether the command has ended normally.
- Always use pulse inputs for operation commands. Leaving input ON prevents BUSY output from turning OFF even after execution of a command has been completed.

#### 1. When returning to origin

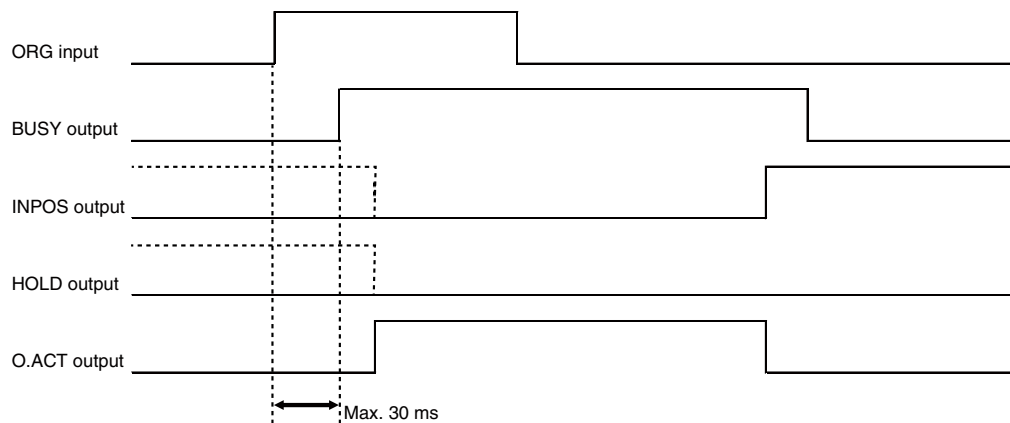

- ① At the rise of ORG input, BUSY output turns ON.
- ② After confirming that BUSY output has turned ON, ORG input is turned OFF (contact is opened).
- ③ Wait until BUSY output is turned OFF.
- ④ When BUSY output turns OFF, INPOS output is ON, and this means that the operation has ended normally.

#### 2. When returning to origin w/ origin shift

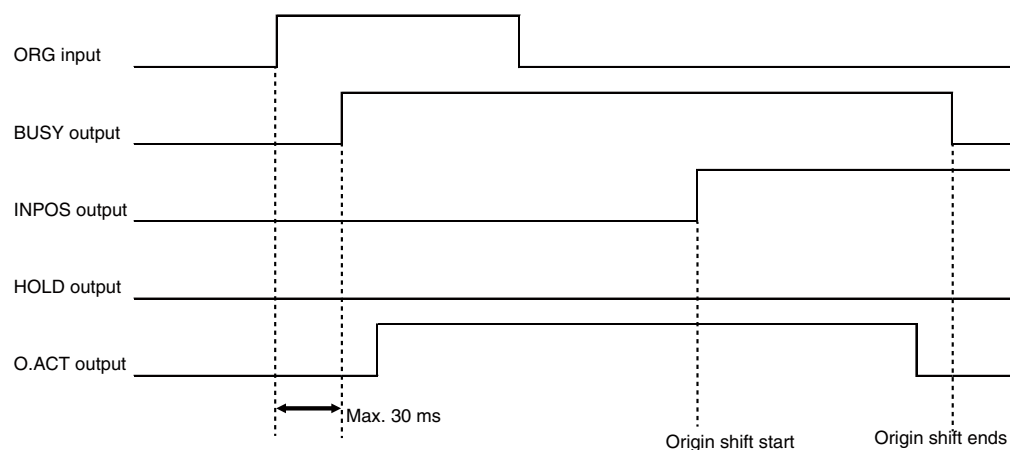

- ① At the rise of ORG input, BUSY output turns ON.
- ② After confirming that BUSY output has turned ON, ORG input is turned OFF (contact is opened).
- ③ Wait until BUSY output is turned OFF.
- ④ When BUSY output turns OFF, INPOS output is ON, and this means that the operation has ended normally.

### 3. Point operation Positioning mode/A and I modes

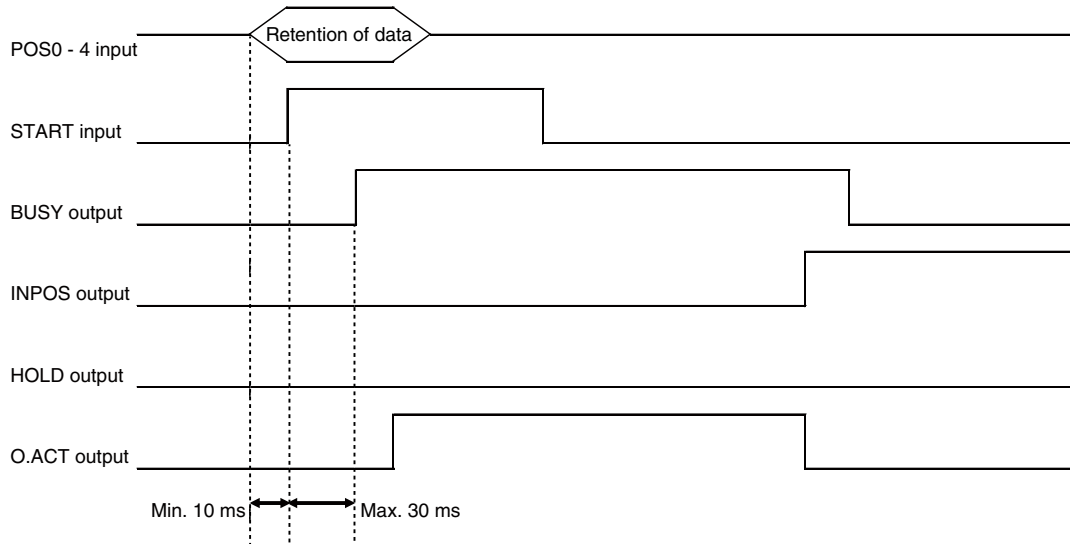

- ① Input the point No. in POS0 to POS4. Maintain this input state until BUSY output turns ON. (Changing the input state too early could cause mis-recognition of data.)
- ② Introduce a delay of at least 10 ms, and then input START input.
- ③ At the rise of an operation command input, BUSY output turns ON.
- ④ Check that BUSY output is ON, and then set the operation command input to OFF (open the contact). After this, the point data can be freely changed.
- ⑤ Wait until BUSY output turns OFF.
- ⑥ When BUSY output turns OFF, INPOS output is ON, and this means that the operation has ended normally.

### 4. Point operation- Pushing mode/U, C, and O modes

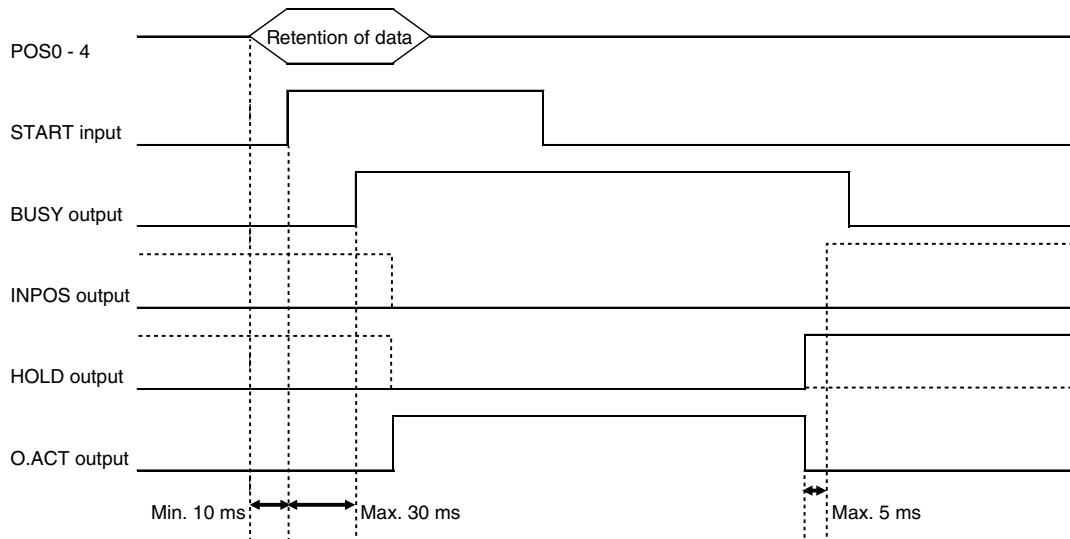

- ① Input the point No. in POS0 to POS4. Maintain this input state until BUSY output turns ON. (Changing the input state too early could cause mis-recognition of data.)
  - ② Introduce a delay of at least 10 ms, and then input START input.
  - ③ At the rise of an operation command input, BUSY output turns ON.
  - ④ Check that BUSY output is ON, and then set the operation command input to OFF (open the contact).  
After this, the point data can be freely changed.
  - ⑤ Wait until BUSY output turns OFF.
  - ⑥ When BUSY output turns OFF, HOLD output is ON, and this means that the operation has ended normally.
- \* If no pushed object is detected, the tooling stops at the limit position. At this time, INPOS output and HOLD output turn OFF.
- \* When the workpiece is pushed within the set range with the size detecting function enabled, HOLD output turns ON, and then INPOS output turns ON within 5 ms. (Pushing mode only)

### 5. When operation input remains on after operation ends (Example: Point operation Positioning mode)

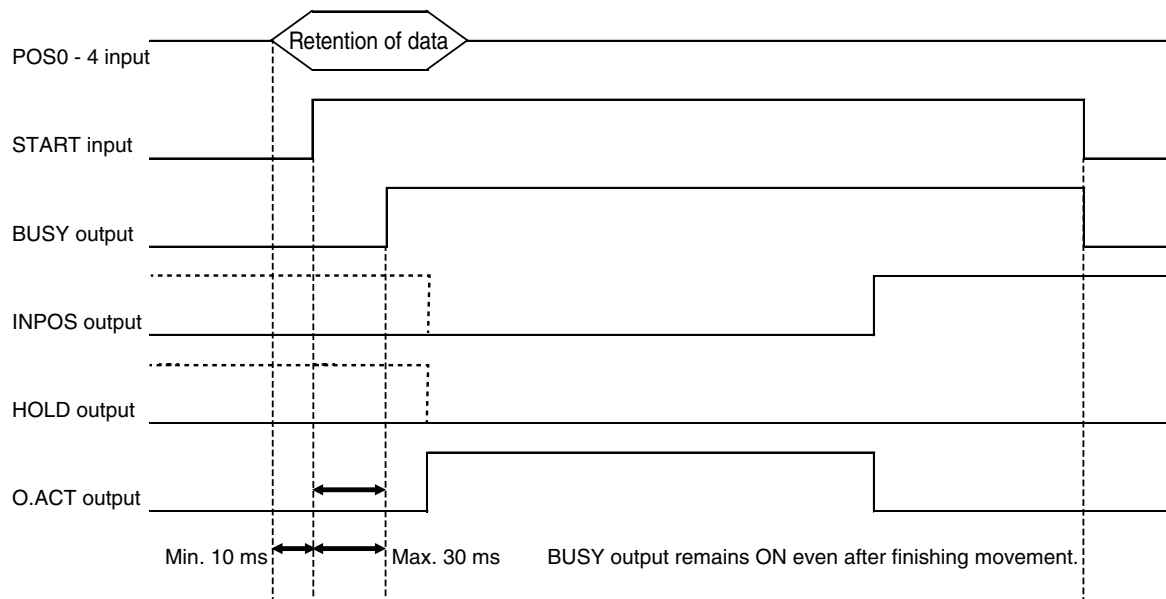

Point operation (START input) is used as an example, but even with other operation input signals, the BUSY signal remains ON. However, ORG input does not work in conjunction with the BUSY output signal, and even when ORG input turns ON, the BUSY output signal turns OFF when return to origin is completed.

### 6. Inching operation

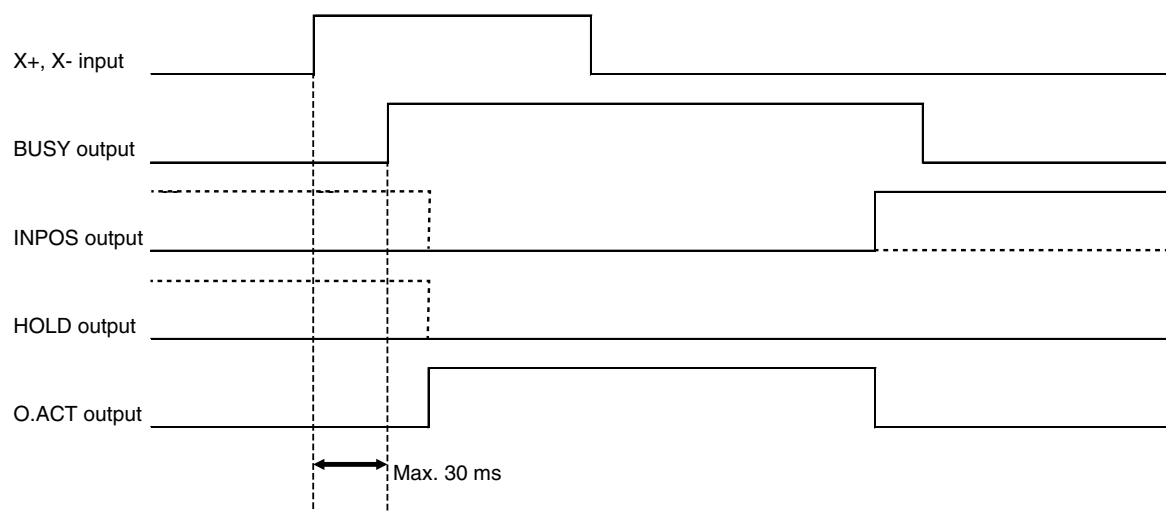

- ① At the rise of an operation command input, BUSY output turns ON.
- ② Check that BUSY output is ON, and then set the operation command input to OFF (open the contact).
- ③ Wait until BUSY output turns OFF.
- ④ When BUSY output turns OFF, INPOS output is ON, and this means that the operation has ended normally.



## 7. Constant-speed movement operation

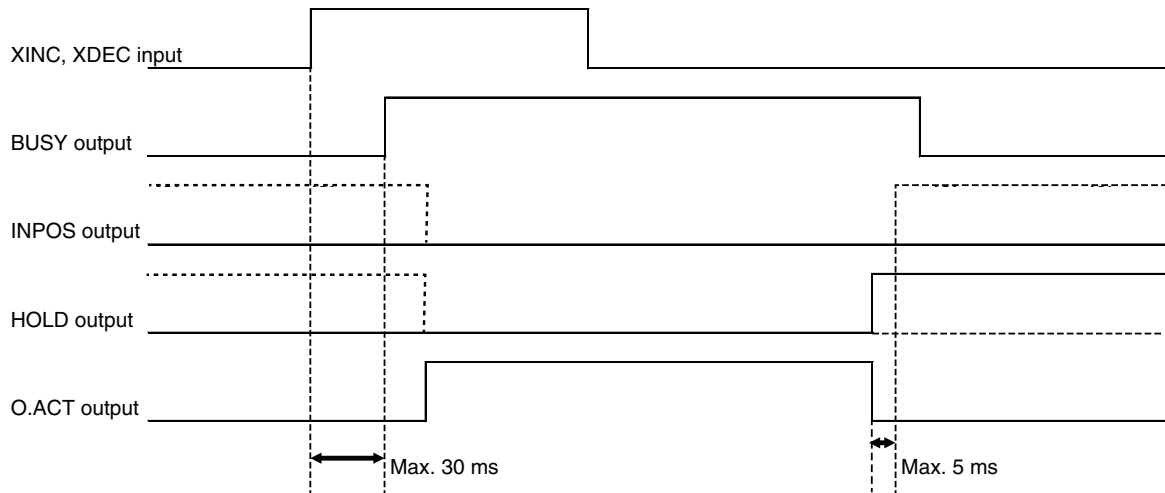

- ① At the rise of an operation command input, BUSY output turns ON.
  - ② Check that BUSY output is ON, and then set the operation command input to OFF (open the contact).
  - ③ Wait until BUSY output turns OFF.
  - ④ When BUSY output turns OFF, HOLD output is ON, and this means that the operation has ended normally.
- \* If no pushed object is detected, the tooling stops at the limit position. At this time, INPOS output and HOLD output turn OFF.

## 8. Direct operation Positioning mode/A and I modes

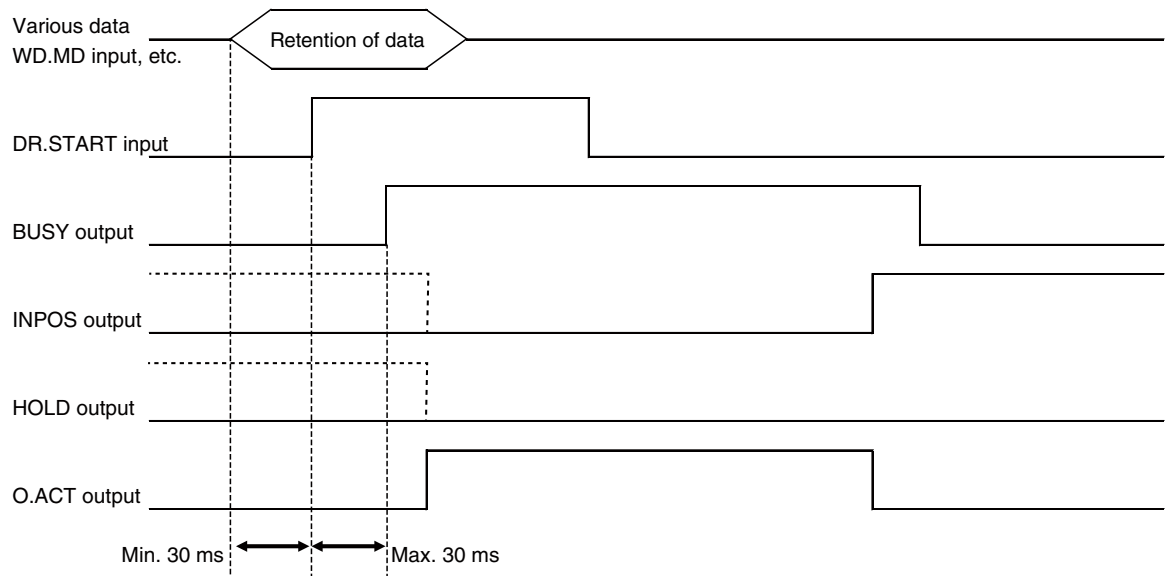

- ① Input immediate data in WR.MD etc. Maintain this input state until BUSY output turns ON. (Changing the input state too early could cause mis-recognition of data.)
- \* The required setting data differs depending on the operation specified. Specify data before starting operation.
- ② Introduce a delay of at least 30 ms, and then input DR.START input.
- ③ At the rise of an operation command input, BUSY output turns ON.
- ④ Check that BUSY output is ON, and then set the operation command input to OFF (open the contact). After that, you may change the immediate data.
- ⑤ Wait until BUSY output turns OFF.
- ⑥ When BUSY output turns OFF, INPOS output is ON, and this means that the operation has ended normally.

## 9. Direct operation Pushing mode/U, C, and O modes Sample pushing position setting operation

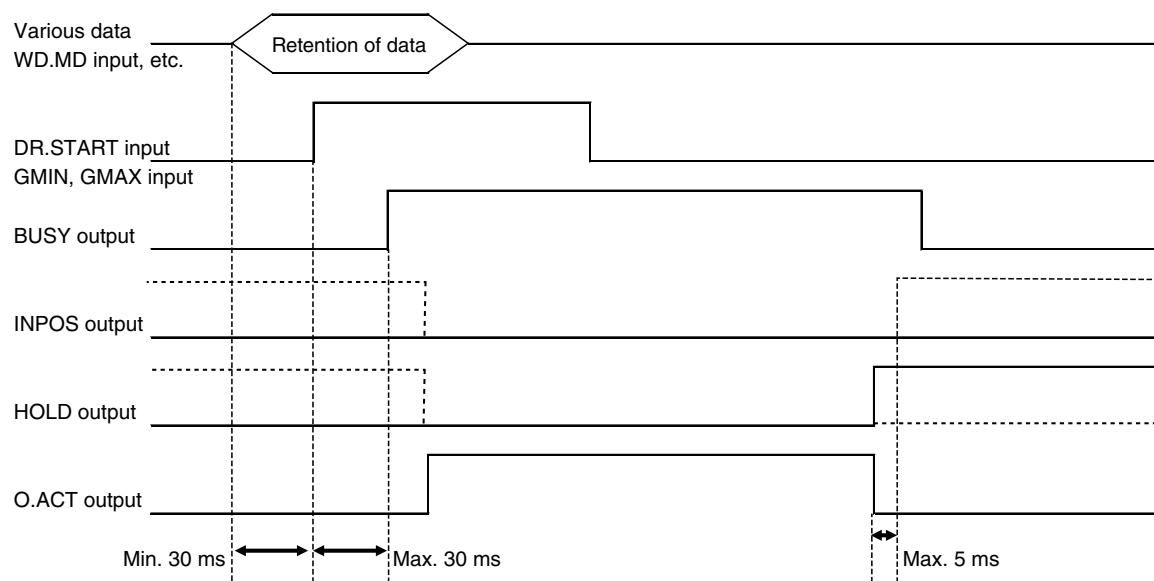

① Input immediate data in WR.MD etc. Maintain this input state until BUSY output turns ON. (Changing the input state too early could cause mis-recognition of data.)

\* The required setting data differs depending on the operation specified. Specify data before starting operation.

② Introduce a delay of at least 30 ms, and then input DR.START input.

③ At the rise of an operation command input, BUSY output turns ON.

④ Check that BUSY output is ON, and then set the operation command input to OFF (open the contact). After that, you may change the immediate data.

⑤ Wait until BUSY output turns OFF.

⑥ When BUSY output turns OFF, HOLD output is ON, and this means that the operation has ended normally.

\* If no pushed object is detected, the tooling stops at the limit position. At this time, INPOS output and HOLD output turn OFF.

\* When the workpiece is pushed within the set range with the size detecting function enabled, HOLD output turns ON, and then INPOS output turns ON within 5 ms. (Pushing mode only)

The required data differs depending on the operation specified. Specify data before starting operation.

Operation	Code	Mode	Position	Speed	Pushing level	Remarks
		WD.MD	WD.POSL WD.POSU	WD.SPD	WR.LV	
Direct operation	DR.START	○	△	○	△	Depends on mode
Operation to set minimum sample pushing position	GMIN	○	×	○	○	
Operation to set maximum sample pushing position	GMAX	○	×	○	○	

## (2) When executing data-related commands

## 10. Initialization Point data

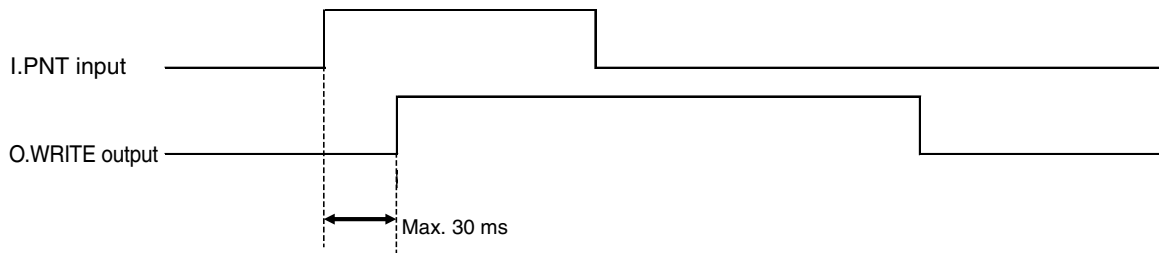

- ① At the rise of a dedicated command input, O.WRITE output turns ON.
- ② Check that O.WRITE output is ON, and then set the dedicated command input to OFF (open the contact).
- ③ Wait until O.WRITE output turns OFF.
- ④ When O.WRITE output turns OFF, this means that the operation has ended normally.

\* For O.WRITE output, the write is completed instantly depending on the amount of data. Therefore, O.WRITE output may not be detected depending on the transmission rate and number of units connected. Create a ladder circuit so that write is judged to be complete if the O.WRITE signal is not output and the current alarm is 0 when 100 ms has elapsed after the write or initialization is executed.

## 11. Initialization Parameter data

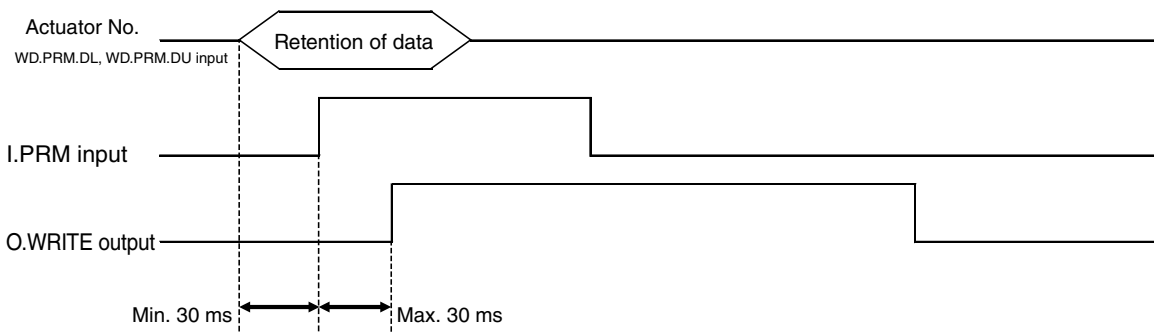

- ① Input the actuator No. in WD.PRM.DL and WD.PRM.DU. Maintain this input state until O.WRITE output turns ON. (Changing the input state too early could cause mis-recognition of data.)
- ② Introduce a delay of at least 30 ms, and then input a dedicated command.
- ③ At the rise of the dedicated command input, O.WRITE output turns ON.
- ④ Check that O.WRITE output is ON, and then set the dedicated command input to OFF (open the contact).
- ⑤ Wait until O.WRITE output turns OFF.
- ⑥ When O.WRITE output turns OFF, this means that the operation has ended normally.

\* For O.WRITE output, the write is completed instantly depending on the amount of data. Therefore, O.WRITE output may not be detected depending on the transmission rate and number of units connected. Create a ladder circuit so that write is judged to be complete if the O.WRITE signal is not output and the current alarm is 0 when 100 ms has elapsed after the write or initialization is executed.

\* If the data is out of the set range, error 53 is output as a current alarm.

\* Set the actuator number to initialize in WD.PRM.DL and WD.PRM.DU.

## 12. Initialization Error history

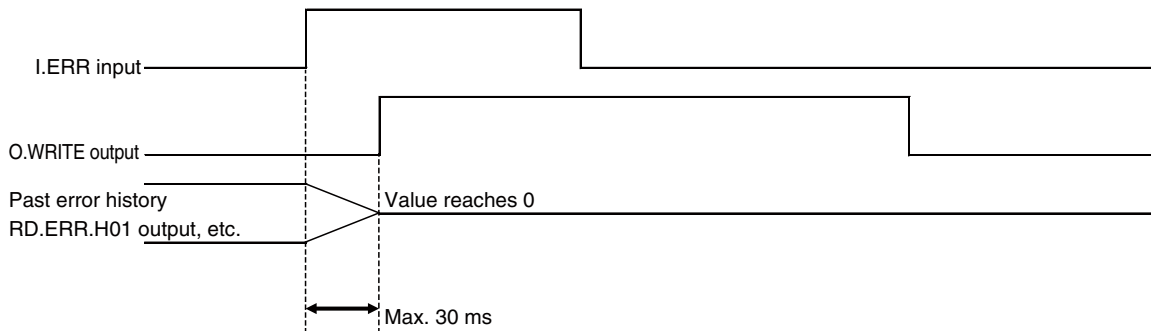

- ① At the rise of a dedicated command input, O.WRITE output turns ON.
  - ② Check that O.WRITE output is ON, and then set the dedicated command input to OFF (open the contact).
  - ③ Wait until O.WRITE output turns OFF.
  - ④ When O.WRITE output turns OFF, this means that the operation has ended normally.
- \* For O.WRITE output, the write is completed instantly depending on the amount of data. Therefore, O.WRITE output may not be detected depending on the transmission rate and number of units connected. Create a ladder circuit so that write is judged to be complete if the O.WRITE signal is not output and the current alarm is 0 when 100 ms has elapsed after the write or initialization is executed.

## 13. Point data write Current position

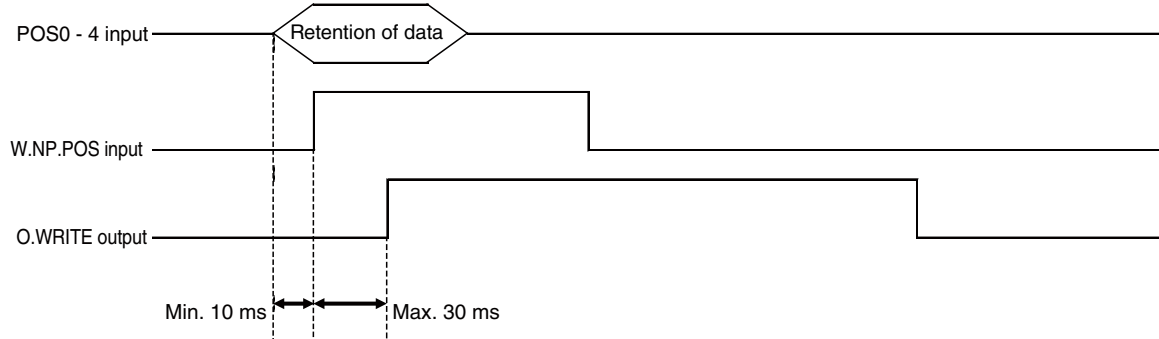

- ① Select the point No. in POS0 to POS4. Maintain this input state until O.WRITE output turns ON. (Changing the input state too early could cause mis-recognition of data.)
  - ② Introduce a delay of at least 10 ms, and then input a dedicated command.
  - ③ At the rise of the dedicated command input, O.WRITE output turns ON.
  - ④ Check that O.WRITE output is ON, and then set the dedicated command input to OFF (open the contact).  
After this, the point data can be freely changed.
  - ⑤ Wait until O.WRITE output turns OFF.
  - ⑥ When O.WRITE output turns OFF, this means that the operation has ended normally.
- \* For O.WRITE output, the write is completed instantly depending on the amount of data. Therefore, O.WRITE output may not be detected depending on the transmission rate and number of units connected.  
Create a ladder circuit so that write is judged to be complete if the O.WRITE signal is not output and the current alarm is 0 when 100 ms has elapsed after the write or initialization is executed.
- \* If the data is out of the set range, error 23 is output as a current alarm.
- \* Specify the point No. to write in POS0 to POS4.

14. Point data write Immediate data setting

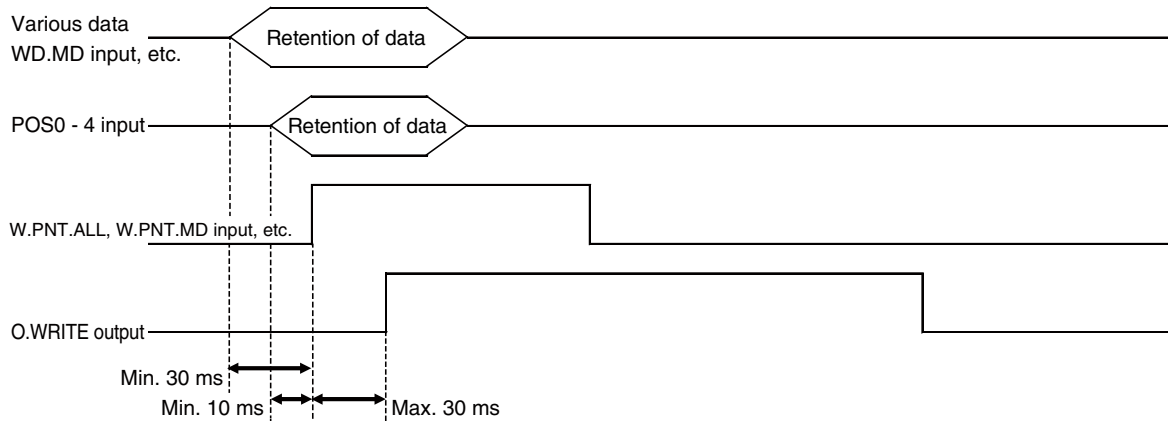

- ① Select the point No. in POS0 to POS4 and input each data in WR.MD etc. Maintain this input state until O.WRITE output turns ON. (Changing the input state too early could cause misrecognition of data.)
  - ② Introduce a delay of at least 30 ms after the data is input in WR.MD etc. and at least 10 ms after the point No. is selected, and then input a dedicated command.
  - ③ At the rise of the dedicated command input, O.WRITE output turns ON.
  - ④ Check that O.WRITE output is ON, and then set the dedicated command input to OFF (open the contact). After this, the point data can be freely changed.
  - ⑤ Wait until O.WRITE output turns OFF.
  - ⑥ When O.WRITE output turns OFF, this means that the operation has ended normally.
- \* For O.WRITE output, the write is completed instantly depending on the amount of data. Therefore, O.WRITE output may not be detected depending on the transmission rate and number of units connected. Create a ladder circuit so that write is judged to be complete if the O.WRITE signal is not output and the current alarm is 0 when 100 ms has elapsed after the write or initialization is executed.
- \* If the data is out of the set range, error 23 is output as a current alarm.
- \* Specify the point No. to write in POS0 to POS4.
- \* The required data differs depending on the write range. Specify each data before executing write.
- \* To clear a value, write 0. With D.PNT input, you can delete multiple values at a time.

Range to write point data	Code	Mode	Position	Speed	Pushing level	Remarks
		WR.MD	WD.POSL WD.POSU	WR.SPD	WR.LV	
All	W.PNT.ALL	○	△	○	△	Depends on mode
Mode	W.PNT.MD	○	x	x	x	
Position	W.PNT.POS	x	○	x	x	
Speed	W.PNT.SPD	x	x	○	x	
Pushing level	W.PNT.LV	x	x	x	○	

## 15. Point data deletion

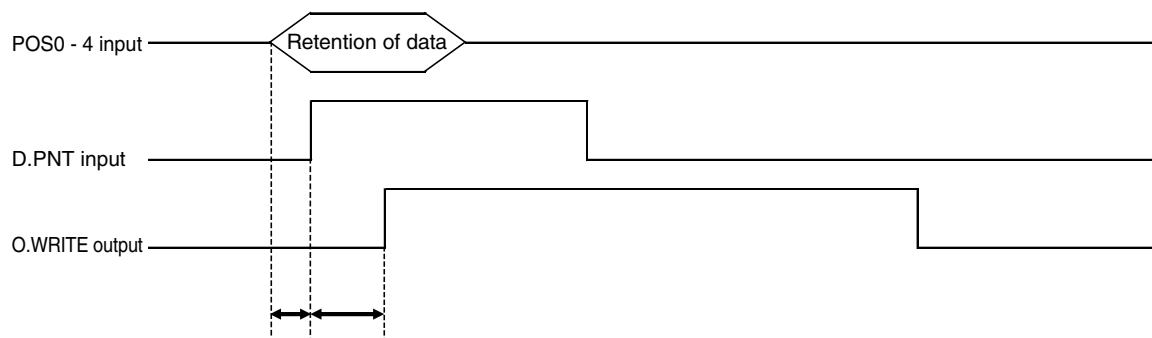

- ① Select the point No. in POS0 to POS4. Maintain this input state until O.WRITE output turns ON. (Changing the input state too early could cause mis-recognition of data.)
  - ② Introduce a delay of at least 10 ms after the point No. is selected, and then input a dedicated command.
  - ③ At the rise of the dedicated command input, O.WRITE output turns ON.
  - ④ Check that O.WRITE output is ON, and then set the dedicated command input to OFF (open the contact). After this, the point data can be freely changed.
  - ⑤ Wait until O.WRITE output turns OFF.
  - ⑥ When O.WRITE output turns OFF, this means that the operation has ended normally.
- \* For O.WRITE output, the write is completed instantly depending on the amount of data. Therefore, O.WRITE output may not be detected depending on the transmission rate and number of units connected. Create a ladder circuit so that write is judged to be complete if the O.WRITE signal is not output and the current alarm is 0 when 100 ms has elapsed after the write or initialization is executed.
- \* If the data is out of the set range, error 23 is output as a current alarm.
- \* Specify the point No. to delete in POS0 to POS4.
- \* By inputting W.PNT.\*\* , you can clear values one by one.

## 16. Parameter data write Current position

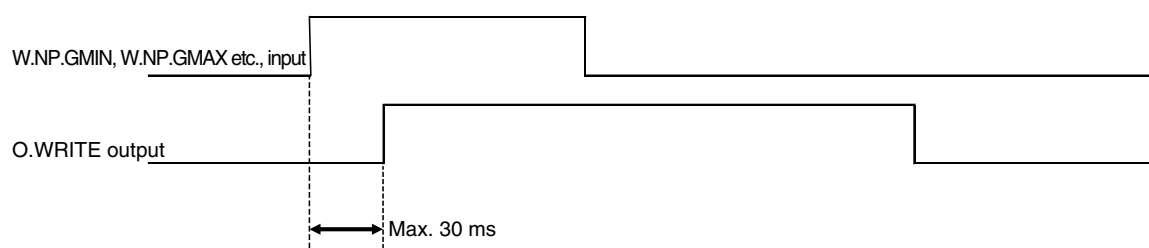

- ① At the rise of a dedicated command input, O.WRITE output turns ON.
  - ② Check that O.WRITE output is ON, and then set the dedicated command input to OFF (open the contact).
  - ③ Wait until O.WRITE output turns OFF.
  - ④ When O.WRITE output turns OFF, this means that the operation has ended normally.
- \* For O.WRITE output, the write is completed instantly depending on the amount of data. Therefore, O.WRITE output may not be detected depending on the transmission rate and number of units connected. Create a ladder circuit so that write is judged to be complete if the O.WRITE signal is not output and the current alarm is 0 when 100 ms has elapsed after the write or initialization is executed.
- \* If the data is out of the set range, error 23 is output as a current alarm.

17. Parameter data write Parameter data

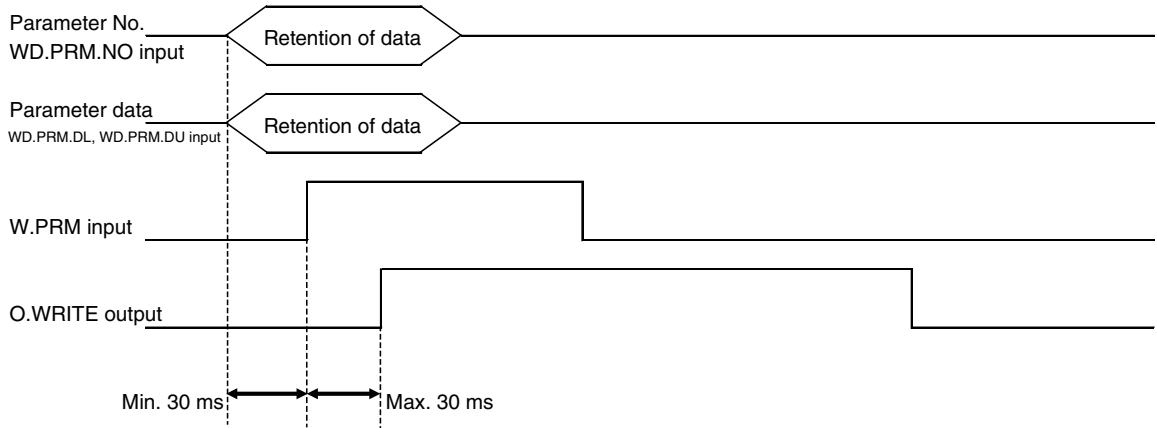

- ① Input the parameter No. in WD.PRM.NO and input each data in WD.PRM.DL and WD.PRM.DU. Maintain this input state until O.WRITE output turns ON. (Changing the input state too early could cause mis-recognition of data.)
  - ② Introduce a delay of at least 30 ms after WD.PRM.DL and WD.PRM.DU input, and then input a dedicated command.
  - ③ At the rise of the dedicated command input, O.WRITE output turns ON.
  - ④ Check that O.WRITE output is ON, and then set the dedicated command input to OFF (open the contact).
  - ⑤ Wait until O.WRITE output turns OFF.
  - ⑥ When O.WRITE output turns OFF, this means that the operation has ended normally.
- \* For O.WRITE output, the write is completed instantly depending on the amount of data. Therefore, O.WRITE output may not be detected depending on the transmission rate and number of units connected. Create a ladder circuit so that write is judged to be complete if the O.WRITE signal is not output and the current alarm is 0 when 100 ms has elapsed after the write or initialization is executed.
- \* If the data is out of the set range, error 23 is output as a current alarm.

18. Write of the number of stations occupied Number of occupied stations

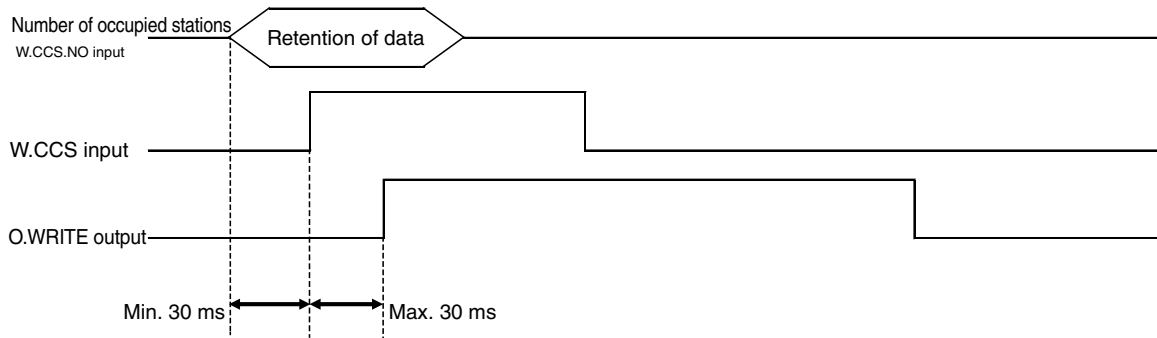

- ① Input the number of stations occupied in WD.CCS.NO. Maintain this input state until O.WRITE output turns ON. (Changing the input state too early could cause mis-recognition of data.)
  - ② Introduce a delay of at least 30 ms after WD.CCS.NO input, and then input a dedicated command.
  - ③ At the rise of the dedicated command input, O.WRITE output turns ON.
  - ④ Check that O.WRITE output is ON, and then set the dedicated command input to OFF (open the contact).
  - ⑤ Wait until O.WRITE output turns OFF.
  - ⑥ When O.WRITE output turns OFF, this means that the operation has ended normally.
- \* For O.WRITE output, the write is completed instantly depending on the amount of data. Therefore, O.WRITE output may not be detected depending on the transmission rate and number of units connected. Create a ladder circuit so that write is judged to be complete if the O.WRITE signal is not output and the current alarm is 0 when 100 ms has elapsed after the write or initialization is executed.
- \* If the data is out of the set range, error 23 is output as a current alarm.
- \* The changed number of stations occupied will be reflected after the power is turned off and on again.

## 19. Point data read Point data

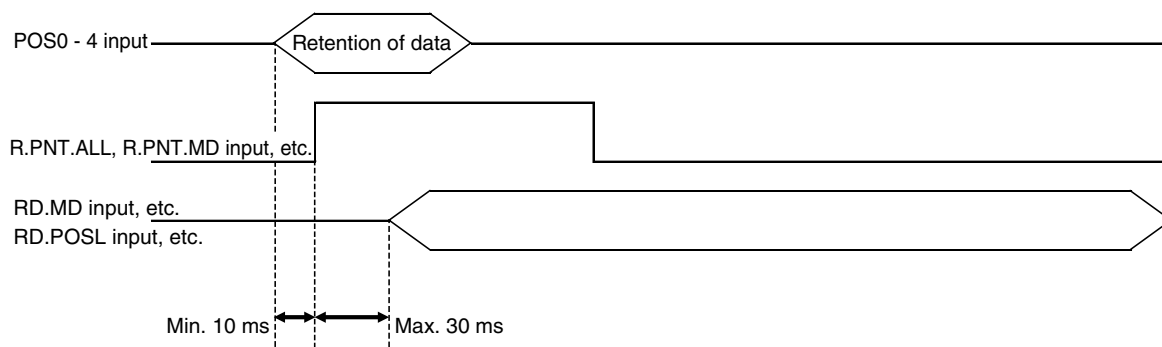

- ① Select the point No. in POS0 to POS4. Maintain this input state until O.WRITE output turns ON. (Changing the input state too early could cause mis-recognition of data.)
  - ② Introduce a delay of at least 10 ms after the point No. is selected, and then input a dedicated command.
  - ③ The specified data is stored at the specified data address within 30 ms after the rise of the dedicated command input.
  - ④ Set the dedicated command input to OFF (open the contact) after confirming that the received data is stored or 30 ms after the rise of the dedicated command input.
- \* Specify the point No. to read in POS0 to POS4.
- \* The stored data differs depending on the read range. Note that the storage location differs depending on the number of stations occupied.
- \* Before reading data, clear the existing data with C.DATA input.
- \* When the point data is cleared, 0 is received.

Range to read point data	Code	Address selection	Storage destination				Remarks
			Mode	Position	Speed	Pushing level	
		When 2-addresses occupied	RD.DL RD.DU	RD.DL RD.DU	RD.DL RD.DU	RD.DL RD.DU	
When 4-addresses occupied	RD.MD	RD.POSL RD.POSU	RD.SPD	RD.LV			
All	R.PNT.ALL		○	○	○	○	Only when 4-addresses occupied
Mode	R.PNT.MD		○	×	×	×	
Position	R.PNT.POS		×	○	×	×	
Speed	R.PNT.SPD		×	×	○	×	
押付レベル	R.PNT.LV		×	×	×	○	



20. Parameter data read Parameter data

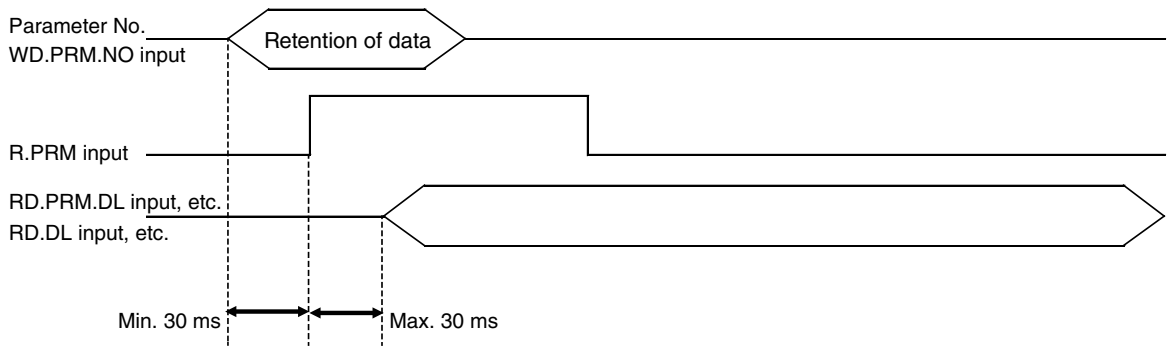

- ① Input the parameter No. in WD.PRM.NO and input each data in WD.PRM.DL and WD.PRM.DU. Hold this data until the storage of the received data is confirmed or 30 ms after the rise of a dedicated command input.
  - ② Introduce a delay of at least 30 ms after WD.PRM.DL and WD.PRM.DU input, and then input a dedicated command.
  - ③ The specified data is stored at the specified data address within 30 ms after the rise of the dedicated command input.
  - ④ Set the dedicated command input to OFF (open the contact) after confirming that the received data is stored or 30 ms after the rise of the dedicated command input.
- \* If the data is out of the set range, error 23 is output as a current alarm.
  - \* Note that the storage location differs depending on the number of stations occupied.
  - \* Before reading data, clear the existing data with C.DATA input.

Code	Address selection	Storage destination
R.PRM	When 2-addresses occupied	RD.DL RD.DU
	When 4-addresses occupied	RD.PRM.DL RD.PRM.DU

21. Version read Version data

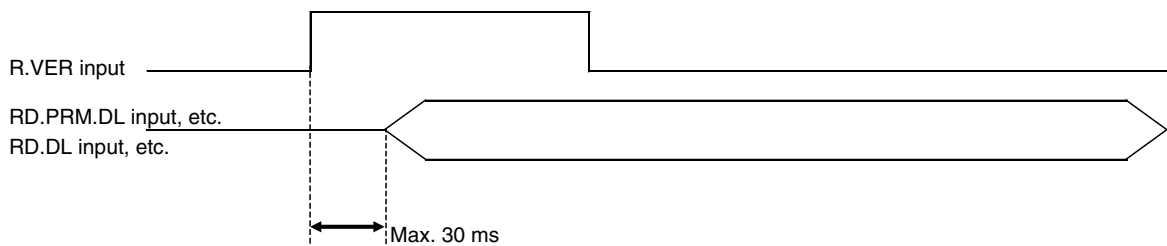

- ① The specified data is stored at the specified data address within 30 ms after the rise of the dedicated command input.
  - ② Set the dedicated command input to OFF (open the contact) after confirming that the received data is stored or 30 ms after the rise of the dedicated command input.
- \* Note that the storage location differs depending on the number of stations occupied.
  - \* Before reading data, clear the existing data with C.DATA input.

Code	Address selection	Storage destination
R.PRM	When 2-addresses occupied	RD.DL RD.DU
	When 4-addresses occupied	RD.PRM.DL RD.PRM.DU

## 22. Data output clear

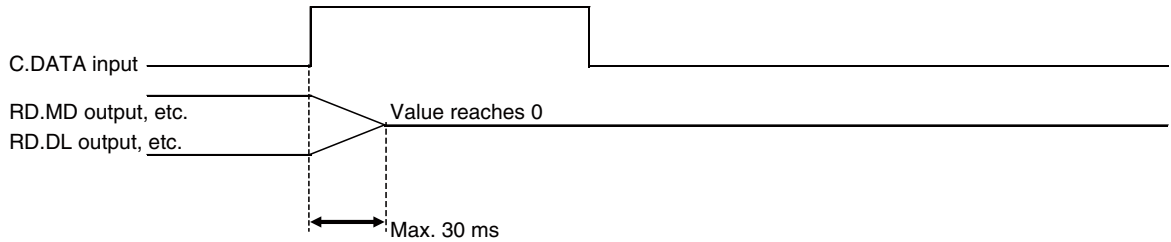

- ① The specified data is stored at the specified data address within 30 ms after the rise of the dedicated command input.
- ② Set the dedicated command input to OFF (open the contact) after data 0 is confirmed or 30 ms after the rise of the dedicated command input.

\* Note that the data to be cleared differs depending on the number of stations occupied.

Code	Address selection	Clear data
C.DATA	When 2-addresses occupied	RD.DL RD.DU
	When 4-addresses occupied	RD.MD RD.POSL RD.POSU RD.SPD RD.LV RD.PRM.DL RD.PRM.DU

## 23. Current alarm output clear

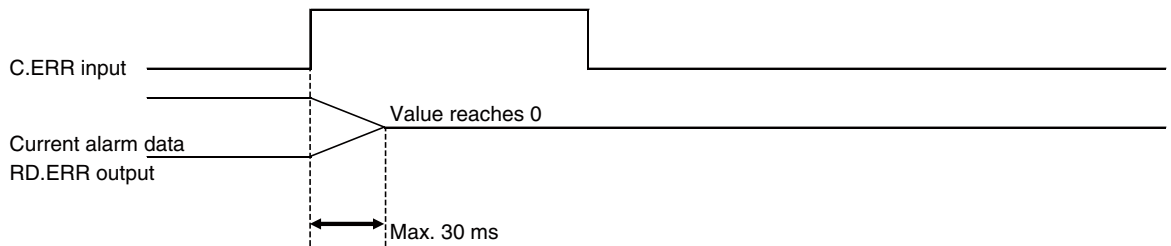

- ① RD.ERR output becomes 0 within 30 ms after the rise of the dedicated command input.
- ② Set the dedicated command input to OFF (open the contact) after confirming that RD.ERR output is 0 or 30 ms after the rise of the dedicated command input.

## 4-4 Actuator number setting

Set the actuator number in the following table in accordance with the actuator type.

Model	EW2G10□ S-10	EW2G10□ S-30	EW2G10□ S-50	EW2G10□ H-10	EW2G10□ H-30	EW2G10□ H-50		
Actuator No.	10	11	12	15	16	17		
Model	EW2G12□ S-20	EW2G12□ S-40	EW2G12□ S-60	EW2G12□ S-80	EW2G12□ H-20	EW2G12□ H-40	EW2G12□ H-60	EW2G12□ H-80
Actuator No.	20	21	22	23	25	26	27	28
Model	EW2G16□ S-20	EW2G16□ S-40	EW2G16□ S-60	EW2G16□ S-100	EW2G16□ H-20	EW2G16□ H-40	EW2G16□ H-60	EW2G16□ H-100
Actuator No.	30	31	32	33	35	36	37	38

Actuator number setting method (Use either of the following methods for the setting.)

1. Using the communication command. (Refer to P. 68.)
2. Using the initialization command in the support software to initialize parameters.  
(For details, see the support software Owner's Manual.)
3. Using I.PRM. (EW2C-H-CCD only) (Refer to P. 50.)

Note: When you purchase the actuator and controller as a set, the controller's actuator number is set to the specified actuator number when shipped.

## 4-5 Point data specifications

P0 = Mode, Position (mm), Speed (mm/s), Gripping level

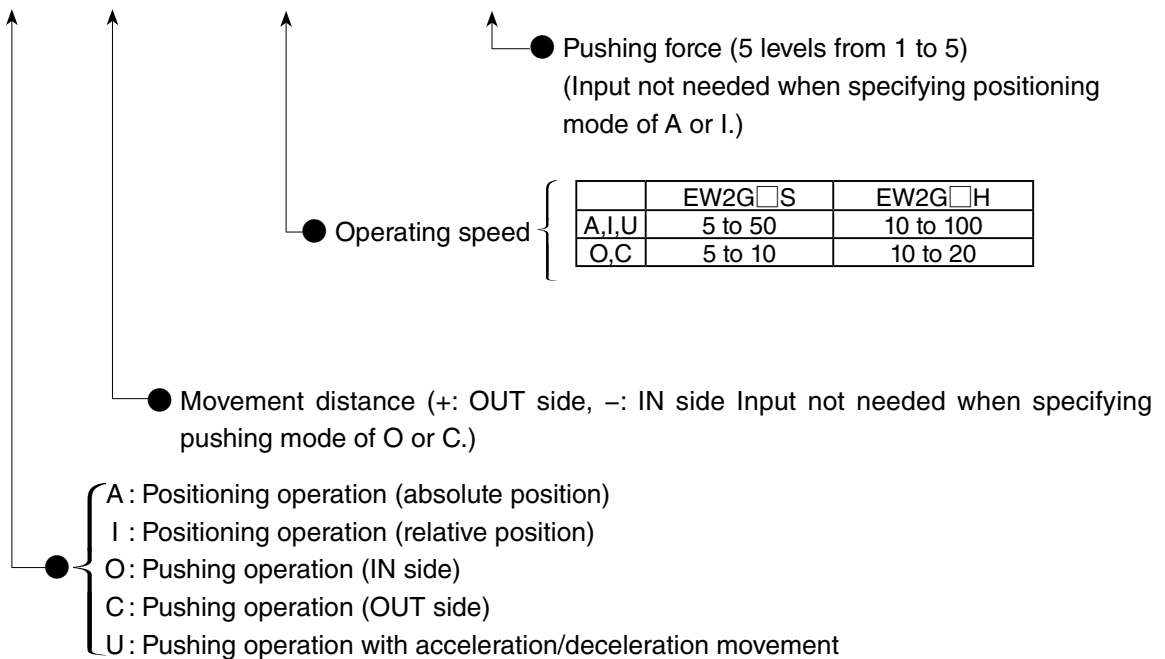

### 4-5-1 Point setting method

Point editing is performed with a personal computer, teaching box, or W.PNT.\*\* (EW2C-H-CCD only).

For the communication parameters and cable specifications, see “4-7 Communication” on P. 61.

Point editing via communication is done by using general-purpose communication software or dedicated support software.

For how to use the support software, see the separately available support software User's Manual.

For how to use the teaching box, see the separately available teaching box User's Manual.

For setting with W.PNT.\*\*, refer to P. 51.

[Example] When editing and checking point data with a communication command

- Using the communication command @WPNT to edit

#### WPNT

Function	Writes point data.
Format	@address, WPNT, point No., mode, position, speed, force c/r
Transmission example	@0, WPNT, 0, A, 3.5, 50 c/r
Response	OK c/r
Explanation	For the data format, refer to P. 58.

- Using the communication command @?PNT to check the point data after editing

#### ?PNT

Function	Reads the specified point data.
Format	@address, ?PNT, point No. c/r
Transmission example	@0, ?PNT, 0 c/r
Response	OK,A, 3.5,50 c/r ······ Absolute position of 3.5 mm, speed of 50 mm/s
Explanation	For the contents of the response data, refer to P. 58.

### ● Operation modes of Low Profile Electric Slider

Mode	Positioning		Pushing <sup>Note</sup>		Pushing with acceleration/deceleration movement
	Moves to the specified point with acceleration/deceleration, and then stops.		Operates at constant speed, and pushes at the set force.		Performs pushing operation during acceleration/deceleration movement.
Setting value	A	I <sup>Note 1</sup>	C	O	U
Description	Moves to the specified point position in the coordinate system where the origin is 0	Moves from the current position to the specified point position	(+) side (OUT side)	(-) side (IN side)	Operates to the specified point, and performs pushing operation at the speed set in PRM7 from the distance forward of the point set in PRM8
Operation pattern					
Remarks	—		—		Suitable for soft pushing with high cycle operation.

Note 1: If the tooling is moved manually and then operated in mode I, the tooling is operated by using the position before it was moved manually as a reference position.

Note 2: The workpiece must be pushed in pushing mode (C or O) or in pushing mode (U) with acceleration/deceleration movement. If the workpiece is pushed in positioning mode (A or I), an alarm is output, and the workpiece cannot be pushed normally.

## 4-6 How to use the size detecting function

### 4-6-1 When using an actual workpiece for size detecting range setting

Procedure	Communication command	Remarks
① Execute return to origin.	@0,ORG	
② Place the minimum sample in place, and set the dimensions.	@0,GMIN,C(O), speed, pushing force	Use HOLD ON to save the pushing position in PRM32
③ Execute return to origin.	@0,ORG	
④ Place the maximum sample in place, and set the dimensions.	@0,GMAX,C(O), speed, pushing force	Use HOLD ON to save the pushing position in PRM31
5. Activate the size detecting function.	@0,WPRM,33,1	PRM33 = 0 deactivates the size detecting function.

- With the above settings, the size detecting function is enabled from the next pushing operation (in O, C, or U mode).  
(A and I modes are not supported.)
- When doing the settings, use communication commands to specify the pushing direction. (C: + direction (OUT side), O: - direction (IN side))
- When the workpiece is pushed and HOLD turns ON, if Minimum sample dimension < Pushing dimension < Maximum sample dimension, INPOS turns ON, otherwise INPOS stays OFF.

**Caution 1: When Minimum sample dimension = Maximum sample dimension, or when Minimum sample dimension > Maximum sample dimension, the size detecting function is disabled.**

**Caution 2: Set the value of PRM31 and PRM32 to be the same sign (+ or -). (When either of the two is 0, or when they are of opposite sign, the size detecting function becomes invalid.)**

### 4-6-2 When using direct input for size detecting function setting

Procedure	Example of communication command	Remarks
① Input the pushing position when pushing the minimum sample.	@0,WPRM,32,500	The pushing position of the minimum sample is assumed to be 5 mm.
② Input the pushing position when pushing the maximum sample.	@0,WPRM,31,450	The pushing position of the maximum sample is assumed to be 4.5 mm.
③ Activate the size detecting function.	@0,WPRM,33,1	PRM33 = 0 deactivates the size detecting function.

**Caution: The values written in PRM31 and 32 are not workpiece dimensions. Instead, they are the pushed positions when pushing the workpiece. Input values based on calculations of the workpiece dimensions and the table position after executing return to origin, or input values based on the confirmed movement distance when pushing the workpiece (at @?POS).**

[Method for calculation of the movement distance]

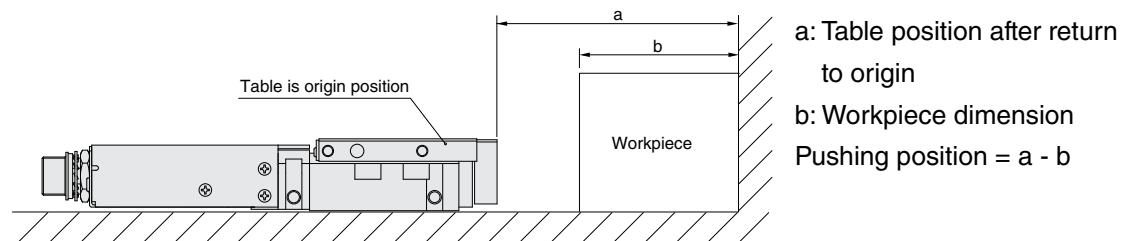

**Caution: Regarding how to use the support software and teaching box, see the Owner's Manual for each.**

## 4-7 Communication

To communicate (initialization/point data and parameters/operation) with an external device (USB-RS485 converter/teaching box), connect to the “S1” connector.

For daisy chain connection, connect to “S2.”

**Note 1: For controller settings, use the USB-RS485 converter or teaching box.**

### 4-7-1 Communication parameter specifications

Communication specifications

Item	Specifications
Baud rate	115.2kbps
Stop bit	1
Start bit	1
Parity bit	Odd number
Data bit length	8
Communication method	Half duplex, asynchronous method

### 4-7-2 Communication cable

Connector S1: SM05B-GHS-TB (JST)

S2: DF3-4P-2DS (HRS)

- When using the USB-RS485 converter to connect to a personal computer

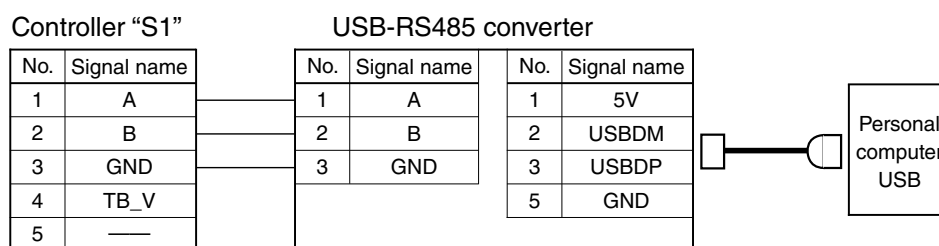

Terminal layout and wiring (USB-RS485 converter-personal computer)

- When connecting to the teaching box

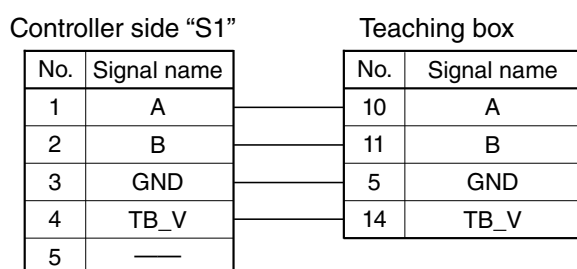

Terminal layout and wiring (teaching box)

### 4-7-3 Addresses

You can set the address for RS485 with the address switch (AD switch) on the front of the controller. You can also set the address for RS485 without using the AD switch. See “4-8 Parameters” on P. 69.

Note: Do not connect devices having the same addresses in daisy chain connection.

### 4-7-4 Communication commands

To facilitate easy communication with external equipment, communication commands are as standard.

@<Address>,<Command>[,<Operand 1>][,<Operand 2>][,<Operand 3>][,<Operand 4>][,<Operand \*>]c/r

## 4-7-5 List of communication commands

Classification	Command	Operand 1	Operand 2	Operand 3	Operand 4	Operand 5	Command description
Actuator operation	ORG						Returns to origin
	MOVD	Coordinate value (mm)	Speed (mm/s)				Executes coordinate specified movement
	MOVH	Coordinate value (mm)	Speed (mm/s)	Force			Executes coordinate specified pushing operation
	MOVP	Point No.					Moves to the specified point
	GMIN	Pushing direction	Speed (mm/s)	Force			Sets position to push minimum sample for size detecting function
	GMAX	Pushing direction	Speed (mm/s)	Force			Sets position to push maximum sample for size detecting function
	X+						(+) movement by specified distance
	X-						(-) movement by specified distance
	XINC						(+) movement at constant speed
	XDEC						(-) movement at constant speed
	STOP						Interrupts operation
Data handling	?POS						Reads current position
	?PRM	Parameter No.					Reads specified parameter
	?PNT	Point No.					Reads specified point data
	?ORG						Confirms return to origin
	?VER						Reads version number
	?DIO						Reads I/O states
	?MOVE						Reads whether or not operation is in progress
	?ERR						Reads error history records
	?EALL						Reads all error history records
	WPNT	Point No.	Mode	Position (speed)	Speed (force)	Force	Writes point data
	WPRM	Parameter No.	Data				Writes parameters
DPNT	Point No.					Deletes point data	
Utilities	IPNT						Initializes all point data
	IPRM	Actuator No.					Initializes all parameters
	IERR						Initializes error history

Classification	Response	Description
Response from controller	OK	Normal completion of operation
	NG	Error generated Error number, after comma
	STOP	Stop command Stop number after comma

\* For details on the error and stop numbers, refer to P. 72, P. 73, and P. 75.

## 4-7-6 Details of communication commands

(1) **ORG**

Function	Return to origin.
Format	@address,ORG c/r
Transmission example	@0,ORG c/r
Response	OK c/r

(2) **MOVD**

Function	Performs positioning to the specified position (absolute position of origin reference) at the specified speed.
Format	@address,MOVD,position,speed c/r
Transmission example 1	@0,MOVD,3.5, 50 c/r
Response	OK c/r
Explanation	Moves at speed of 50 mm/s to the 3.5 mm position from the origin.

Transmission example 2	@0,MOVD ,1000, 20 c/r
Response	NG ,23 c/r
Explanation	Data beyond the limit of the software cannot be entered.

(3) **MOVH**

Function	Performs pushing operation at the specified speed and pushing force in direction to the specified position (absolute position of origin reference). (Mode U operation. Refer to P. 58.)
Format	@address,MOVH,position,speed,force c/r
Transmission example 1	@0,MOVH, 3.5,50, 5 c/r
Response	OK c/r
Explanation	Moves in positioning mode to a point 3.5 cm from the origin at a speed of 50 mm/s and performs pushing operation with a pushing force of 5.

(4) **MOVP**

Function	Operates by using the specified PNT No. data.
Format	@address,MOVP, point No. c/r
Transmission example 1	@0,MOVP, 2 c/r
Response	OK c/r
Explanation	Performs the operation specified in PNT No 2.
Transmission example 2	@0,MOVP, 12 c/r
Response	NG ,52 c/r
Explanation	An error occurs because no point data exists in PNT No 12.

(5) **GMIN (GMAX)**

Function	Sets the pushing position for the minimum sample (maximum sample) when using the size detecting function.
Format	@address,GMIN, pushing direction, speed, pushing force c/r
Transmission example	@0,GMIN, C, 10, 5 c/r
Response	OK c/r
Explanation	This means that pushing operation and setting are completed normally.



**(6) X+ (X-)**

Function	Moves by only the specified distance to + side (- side) at the speed shown below. Movement distance = PRM25/100 [mm] Moving speed = PRM24 [mm/s]
Format	@ address,X+c/r
Transmission example	@0,X+c/r
Response	OK c/r

**(7) XINC (XDEC)**

Function	Moves continuously at the speed shown in the following equation to + side (- side). The operation stops when the stop command is input or the tooling reaches the software limit. Moving speed = PRM24 [mm/s]
Format	@address,XINC c/r
Transmission example	@0,XINC c/r
Response	OK c/r

**(8) STOP**

Function	Stops operation.
Format	@address, STOP c/r
Transmission example	@0, STOP c/r
Response	STOP, 61 c/r

**(9) ?POS**

Function	Reads the current position.
Format	@ address,?POS c/r
Transmission example	@0, ?POS c/r
Response 1	OK, 6.65 c/r ······ The current position is 6.65 mm from the origin.
Response 2	NG, 01, 3.05 ······ While an alarm is being output, the current position is returned with the details of the NG. (When the overtimes alarm is being output, the current position is 3.05 mm from the origin position.)

**(10) ?PRM**

Function	Reads the specified parameter.
Format	@ address,?PRM, parameter No. c/r
Transmission example	@0, ?PRM, 25 c/r
Response	OK, 100 c/r

**(11) ?PNT**

Function	Reads the specified point data.
Format	@address,?PNT, point No. c/r
Transmission example	@0,?PNT, 10 c/r
Response	OK,A, 5.00, 35 c/r ····· Absolute position of 5 mm, speed of 35 mm/s
Explanation	For the contents of the response data, refer to P. 58.

**(12) ?ORG**

Function	Confirms whether return to origin has been completed or not.
Format	@address,?ORG c/r
Transmission example	@0, ?ORG c/r
Response 1	OK, 0 c/r ····· Return to origin not completed
Response 2	OK, 1 c/r ····· Return to origin completed

**(13) ?VER**

Function	Checks the controller software version number
Format	@address, ?VER c/r
Transmission example	@0, ?VER c/r
Response	OK, 2.00 c/r

**(14) ?DIO**

Function Reads custom input/output status.  
 Format @address, ?DIO c/r  
 Transmission example @0, ?DIO c/r  
 Response OK, 0, 0, 0, 0, 0, 0, 0, 0, 0, 0, 0, 0 c/r

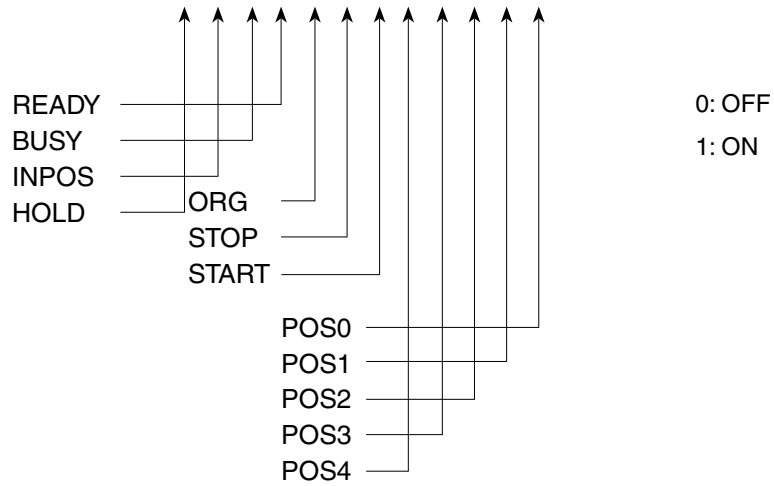

**(15) ?MOVE**

Function Reads the operation status of the actuator.  
 Format @address, ?MOVE c/r  
 Transmission example @0, ?MOVE c/r  
 Response OK, 0, 0, 1, 1 c/r

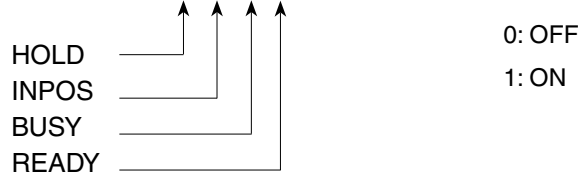

Explanation Confirms the completion of operation after performing operation with @ address, ORG etc.

**(16) ?ERR**

Function Reads the latest alarm and error history records.  
 Format @address, ?ERR c/r  
 Transmission example @0, ?ERR c/r  
 Response OK, 23 c/r

Note: Alarm No. 04: Power supply voltage drop is not saved.

**(17) ?EALL**

Function Reads alarm and error history records. (Up to 16 latest records. The latest record is added to the right end.)

Format @address,?EALL c/r

Transmission example @0, ?EALL c/r

Response OK, 32, 01, 03 c/r  
(In this case, 03 indicates the latest error record.)

Note: Alarm No. 04: Power supply voltage drop is not saved.

**(18) WPNT**

Function Writes point data.

Format @address, WPNT, point No., mode, position, speed, force c/r

Transmission example @0, WPNT, 0, A, 3.5, 50 c/r

Response OK c/r

Explanation For the data format, refer to P. 58.

**(19) WPRM**

Function Writes parameters.

Format @address, WPRM, parameter No., value c/r

Transmission example @0, WPRM, 2, -400 c/r

Response OK c/r

(Sends only data that requires changes.)

Note: PRM0 indicates the actuator number, so cannot be changed by writing parameters.

Change it by initializing parameters.

**(20) DPNT**

Function Deletes point data.

Format @address, DPNT, point No. c/r

Transmission example @0, DPNT, 0 c/r

Response OK c/r

**(21) IPNT**

Function Deletes all point data.

Format @address, IPNT c/r

Transmission example @0, IPNT c/r

Response OK c/r

**(22) IPRM**

Function                      Resets parameters to their initial values.  
 Format                         @address, IPRM, actuator No. c/r  
 Transmission example     @0, IPRM, 10 c/r  
 Response                     OK c/r

\* The first 2 digits in the serial No. on the actuator unit are the actuator No.  
 Check the actuator No. on the actuator unit, and then initialize the parameters.

Model	EW2G10□ S-10	EW2G10□ S-30	EW2G10□ S-50	EW2G10□ H-10	EW2G10□ H-30	EW2G10□ H-50		
Actuator No.	10	11	12	15	16	17		
Model	EW2G12□ S-20	EW2G12□ S-40	EW2G12□ S-60	EW2G12□ S-80	EW2G12□ H-20	EW2G12□ H-40	EW2G12□ H-60	EW2G12□ H-80
Actuator No.	20	21	22	23	25	26	27	28
Model	EW2G16□ S-20	EW2G16□ S-40	EW2G16□ S-60	EW2G16□ S-100	EW2G16□ H-20	EW2G16□ H-40	EW2G16□ H-60	EW2G16□ H-100
Actuator No.	30	31	32	33	35	36	37	38

**(23) IERR**

Function                      Deletes all alarm and error history records.  
 Format                         @address, IERR c/r  
 Transmission example     @0, IERR c/r  
 Response                     OK c/r

## 4-8 Parameters

The controller does not have any potentiometer, dip switches, or any other hardware adjustment mechanism.

Instead, it uses parameters that can easily be set with a personal computer, the teaching box, or W.PRM.\*\* (for EW2C-H-CCD only). This section describes how to change and set the parameters, and gives details of each parameter.

### Safety

Because software is used to detect motor overload (overtimes) and other abnormalities, the controller parameters must be set correctly to match the actuator number of the connected actuator. When the controller was purchased as an order option together with the actuator, the parameters had already been initialized to match the actuator, but in any case other than that, first set the actuator No. in accordance with the actuator being used, before operating the controller. If any problem is found, please contact us.

### Caution:

**Changing parameters other than those described in this manual could result in fatal damage or defects in the actuator and controller.**

### 4-8-1 Parameter setting method

Parameter editing is performed with a personal computer, the teaching box, or W.PRM.\*\* (for EW2C-H-CCD only). For the communication parameters and cable specifications, see "4-7 Communication" on P. 61.

The editing of parameters via communication is carried out by using general-purpose communication software or dedicated support software.

For instructions of the software, see the separately available support software Owner's Manual.

For how to use the teaching box, see the separately available teaching box User's Manual.

For setting with W.PRM.\*\*, refer to P. 58.

## 4-8-2 Explanation of parameters

PRM0 : Actuator No.

Displays the actuator No. This parameter is only for reading. Change it by initializing parameters.

PRM1 : (+) software limit

Sets the (+) side actuator movement range. (Enabled only in operation mode A, I, C, or O.) For safety, always set a suitable value.

Input range 0 to 19995 (×0.01 mm)

Initial value

Actuator No.	10,15	11,16	12,17	20,25	21,26	22,27	23,28	30,35	31,36	32,37	33,38
Initial value	1000	3000	5000	2000	4000	6000	8000	2000	4000	6000	10000

PRM2 : (-) software limit

Sets the (-) side actuator movement range. (Enabled only in operation mode A, I, C, or O.) For safety, always set a suitable value.

Input range -19995 to 0 (×0.01 mm)

Initial value 0

PRM5 : Origin return direction

Sets the origin return direction. Selecting 0 sets the origin return on the IN side, and selecting 1 sets the origin return on the OUT side.

Input range 0, 1

Meaning 0: IN side 1: OUT side

Initial value 0

PRM7 : Pushing speed

Sets the pushing speed in the U mode. (mm/s)

Input range

Actuator No.	10 - 12, 20 - 23, 30 - 33	15 - 17, 25 - 28, 35 - 38
Input range	5 to 10	10 to 20

Initial value 10

PRM8 : Low-speed movement distance

Sets the distance at low-speed movement from the position forward of the point specified in the U mode. (Refer to P. 57.)

Input range 5 to 19995 (×0.01 mm)

Initial value 100

PRM9 : Limit width

Sets the range where pushing operation is performed from the position specified in the U mode. (Refer to P. 57.)

When the movement distance exceeds the limit range during pushing operation, the operation stops due to the "Limit exceeded" error.

Input range 5 to 19995 (×0.01 mm)

Initial value 100

PRM10 : Origin return speed

Sets the speed when returning to origin. (mm/s)

Actuator No.	10 - 12, 20 - 23, 30 - 33	15 - 17, 25 - 28, 35 - 38
Input range	5 to 10	10 to 20
Actuator No.	10 - 12, 20 - 23, 30 - 33	15 - 17, 25 - 28, 35 - 38
Initial value	10	20

PRM14 : Mode selection (except for EW2C-H-CCD)

Selects operation mode. The mode changes when the power is turned off and on again.

Input range 0 to 2

Meaning 0: Standard mode

1: Easy mode (single solenoid type)

2: Easy mode (double solenoid type)

Initial value 0

**PRM21 : Stroke**

Input the effective stroke of the actuator.

Input range                    5 to 19995                    (×0.01 mm)

Actuator No.	10,15	11,16	12,17	20,25	21,26	22,27	23,28	30,35	31,36	32,37	33,38
Initial value	1000	3000	5000	2000	4000	6000	8000	2000	4000	6000	10000

**PRM24 : Moving speed when teaching**

Parameter for specifying the speed during movement by the communication command X+, X-, XINC, or XDEC.

This is also used during teaching playback for point.

Input range

Actuator No.	10 - 12, 20 - 23, 30 - 33	15 - 17, 25 - 28, 35 - 38
Input range	5 to 10	10 to 20

Initial value                    10

**PRM25 : Movement distance when teaching**

Sets the movement distance with the communication command X+ or X-.

Input range                    5 to 19995                    (×0.01 mm)

Initial value                    10

**PRM26 : Pushing force during teaching movement**

Sets the pushing force during movement by the communication command XINC or XDEC.

Input range                    1 to 5

Initial value                    5

**PRM31 : Maximum sample pushing position**

Sets the pushing position when pushing a maximum sample when using the size detecting function. (Initial value: 0)

(X0.01 mm)

Actuator No.	10,15	11,16	12,17	20,25	21,26	22,27	23,28
Input range	-1000 - 1000	-3000 - 3000	-5000 - 5000	-2000 - 2000	-4000 - 4000	-6000 - 6000	-8000 - 8000

Actuator No.	30,35	31,36	32,37	33,38
Input range	-2000 - 2000	-4000 - 4000	-6000 - 6000	-10000 - 10000

**PRM32 : Minimum sample pushing position**

Sets the pushing position when pushing a minimum sample when using the size detecting function. (Initial value: 0)

(X0.01 mm)

Actuator No.	10,15	11,16	12,17	20,25	21,26	22,27	23,28
Input range	-1000 - 1000	-3000 - 3000	-5000 - 5000	-2000 - 2000	-4000 - 4000	-6000 - 6000	-8000 - 8000

Actuator No.	30,35	31,36	32,37	33,38
Input range	-2000 - 2000	-4000 - 4000	-6000 - 6000	-10000 - 10000

**PRM33 : Size detecting function**

Switches between enabling/disabling the size detecting function.

Input range                    0, 1

Meaning                        0: Function disabled        1: Function enabled

Initial value                    0



**PRM35 : Origin shift distance**

Sets the virtual origin. Always execute return to origin after setting it. When executing return to origin, the product temporarily returns to its mechanical origin and then moves the distance set for the origin shift position to complete return to origin. And, that position becomes 0. For example, if an accidental position deviation occurred, it is ordinarily necessary to re-teach all point data. However, by setting the amount of deviation with this parameter, a quick recovery is possible without taking the time to re-teach.

Input range                -19995 to 19995                (×0.01 mm)  
Initial value                0

**PRM36 : Origin shift speed**

Sets the speed for origin shift. (mm/s)

Input range	Actuator No.	10 - 12, 20 - 23, 30 - 33	15 - 17, 25 - 28, 35 - 38
	Input range	5 to 50	10 to 100

Initial value                10

**PRM60 : Address setting for RS485**

Sets the address for RS485 when a parameter is selected by using PRM61 (PRM61 = 1). The value does not change by parameter initialization.

Input range                0 to F (16 patterns)  
Initial value                0

**PRM61 : Address setting method for RS485**

Selects the address setting method for RS485. The value does not change by parameter initialization.

Input range                0, 1  
Meaning                    0: Switch 1: Parameter  
Initial value                0

\* The least input increment for distance-related parameters is 0.05 mm.

**PRM62 : Value set for the number of CC-Link stations (for EW2C-H-CCD only)**

Selects the number of CC-Link stations. The value does not change by parameter initialization. The number of CC-Link stations changes when the power is turned off and on again.

Input range                1, 2, 4  
Initial value                1

## 4-9 List of errors

### (1) Command related

Error No.	Item	Description
21	Error	Typing mistake
	Cause	Command is not correct
	Countermeasure	Use the correct command
23	Error	Data error
	Cause	Error in the numerical data
	Countermeasure	Correct the data
24	Error	Overrun error
	Cause	Error in the transferred data
	Countermeasure	Send the correct command
25	Error	Framing error
	Cause	Error in the transferred data, or noise
	Countermeasure	Send the correct command. Turn off the power and remove and insert the communication connector
26	Error	Parity error
	Cause	Error in the transferred data, or noise
	Countermeasure	Send the correct command. Turn off the power and remove and insert the communication connector

## (2) Operation related

Error No.	Item	Description
31	Error	Running
	Cause	Another command is already being executed, so this command cannot be accepted
	Countermeasure	Wait until the current command finishes before inputting the new command
32	Error	Origin incomplete
	Cause	Command cannot be executed because the origin return has not been completed
	Countermeasure	Execute origin return
35	Error	Can't execute
	Cause	The parameter contradicts the operation command
	Countermeasure	Change the parameter or point data
37	Error	Limit exceeded
	Cause	The position to be moved to exceeds the software limit
	Countermeasure	Edit the point data
39	Error	Point setting error
	Cause	The combination of the operation mode, speed, and pushing level is out of the specified range
	Countermeasure	Edit the point data

## (3) System related

Error No.	Item	Description
52	Error	No point data
	Cause	No data has been registered at the specified point number
	Countermeasure	Register the point data
53	Error	No actuator type
	Cause	Actuator number setting is incorrect
	Countermeasure	Check the actuator number, and try the initialization again
56	Error	Data protected
	Cause	Attempted to write to a parameter that is write-protected
	Countermeasure	Writing is allowed only to parameters that are write-enabled
57	Error	No parameter
	Cause	Attempted to read a parameter number that is not registered
	Countermeasure	Read a registered parameter number
58	Error	Saving data
	Cause	Attempted to perform another write operation while writing to non-volatile memory
	Countermeasure	Wait until writing to non-volatile memory is complete before writing

## (4) Stop messages

Error No.	Item	Description
61	Error	Stop command
	Meaning	Stopped due to the stop command
63	Error	Stop input
	Meaning	Stopped due to a STOP input entered from I/O

## 4-10 Easy mode

In this mode, you can perform operation with the same control as for the air cylinder.

Changing PRM14 (initial value: 0) to 1 sets the control method to the single solenoid type, and changing it to 2 sets the control method to the double solenoid type. (The setting changes when the power is turned off and on again.)

[Relevant controllers]

**EW2C-H-NP, EW2C-H-PN, EW2C-H-CC**

Note: Easy mode is unavailable with EW2C-H-CCD.

### 4-10-1 I/O connector signal table for easy mode

NO.	Wire color	Signal name	Description	NO.	Wire color	Signal name	Description
01	Brown	N.C.	N.C.	02	Red	N.C.	N.C.
03	Orange	N.C.	N.C.	04	Yellow	N.C.	N.C.
05	Green	START0	OUT-side start signal	06	Blue	START1	IN-side start signal
07	Purple	STOP	Stop signal	08	Gray	RESET	Alarm reset signal
09	White	READY	Preparation completed output	10	Black	SEN0	OUT-side arrival output
11	Brown	SEN1	IN-side arrival output	12	Red	N.C.	N.C.
13	Orange	24G	- common	14	Yellow	N.C.	N.C.
15	Green	24V GND	Ground	16	Blue	24V IN	24-V input
17	Purple	N.C.	N.C.	18	Gray	24V	+24V
19	White	FG	Frame ground	20	Black	FG	Frame ground

### 4-10-2 Details of input signals for easy mode

There are 4 dedicated command inputs as input signals.

#### ○Dedicated command inputs

Dedicated command inputs are inputs to control from an external device, such as a programmable controller.

To accept START0 and START1 inputs, the READY and STOP signals must meet the following conditions.

- READY output: ON
  - STOP input: OFF
  - START0 input: OFF
  - START1 input OFF (for the single solenoid type)
- \* START1 input is not used for the single solenoid type.
- START0 is accepted both in the ON state (when the contact is closed) and the OFF state (when the contact is open).
- \* For the double solenoid type, START0 and START1 inputs are accepted when the OFF state is switched to the ON state (the moment when the contact closes).

## &lt;Single solenoid type&gt;

## ■ IN/OUT operation start input (START0)

Performs pushing operation based on the set data from the current position.

ON: Performs pushing operation in the OUT-side direction.

OFF: Performs pushing operation in the IN-side direction.

## &lt;Double solenoid type&gt;

## ■ OUT-side operation start input (START0)

Performs pushing operation in the OUT-side direction based on the set data from the current position.

## ■ IN-side operation start input (START1)

Performs pushing operation in the IN-side direction based on the set data from the current position.

## ■ Alarm reset input (RESET)

Clears the alarm when an alarm, such as overtimes, is issued. When an alarm is issued, the alarm must always be reset.

## ■ Operation stop input (STOP)

This is an input to stop the actuator's movement temporarily.

Turning this input ON (closing the contact) while the actuator is operating stops the movement of the actuator. While this input is in the ON state (the contact is in a closed state), no dedicated command from I/O or no program via communication can be executed.

## 4-10-3 Details of output signals for easy mode

## &lt;Single solenoid type&gt;

There are 3 output signals: READY, SEN0, and SEN1.

ON and OFF refer to the turning on and off of the output transistor.

## ○Dedicated outputs

These outputs are for signal interaction with a programmable controller, etc.

## ■ Preparation completed output (READY)

When the controller system is operating normally, this output is set to ON. If an alarm is issued, this output is set to OFF and the motor enters a free state.

## ■ OUT-side pushing operation completed output (SEN0)

This signal turns OFF whenever a dedicated command input (START0 or START1) is accepted, and then turns ON when the OUT-side pushing operation execution process is completed normally. If an error occurs during execution, or if STOP has been input, the signal remains unchanged in the OFF state.

## ■ IN-side pushing operation completed output (SEN1)

This signal turns OFF whenever a dedicated command input (START0 or START1) is accepted, and then turns ON when the IN-side pushing operation execution process is completed normally. If an error occurs during execution, or if STOP has been input, the signal remains unchanged in the OFF state.

## 4-10-4 Parameters

PRM14 : Mode selection (except for EW2C-H-CCD)

Selects operation mode. The mode changes when the power is turned off and on again.

Input range 0 to 2

Meaning 0: Standard mode

1: Easy mode (single solenoid type)

2: Easy mode (double solenoid type)

Initial value 0

PRM17 : OUT-side pushing speed in easy mode (except for EW2C-H-CCD)

Sets the OUT-side pushing speed in easy mode. (mm/s)

Actuator No.	10 - 12, 20 - 23, 30 - 33	15 - 17, 25 - 28, 35 - 38
Input range	5 to 10	10 to 20
Actuator No.	10 - 12, 20 - 23, 30 - 33	15 - 17, 25 - 28, 35 - 38
Initial value	10	20

PRM18 : IN-side pushing speed in easy mode (except for EW2C-H-CCD)

Sets the IN-side pushing speed in easy mode. (mm/s)

Actuator No.	10 - 12, 20 - 23, 30 - 33	15 - 17, 25 - 28, 35 - 38
Input range	5 to 10	10 to 20
Actuator No.	10 - 12, 20 - 23, 30 - 33	15 - 17, 25 - 28, 35 - 38
Initial value	10	20

PRM19 : OUT-side pushing force in easy mode (except for EW2C-H-CCD)

Sets the OUT-side pushing force in easy mode.

Input range 1 to 5

Initial value 5

PRM20 : IN-side pushing force in easy mode (except for EW2C-H-CCD)

Sets the IN-side pushing force in easy mode.

Input range 1 to 5

Initial value 5

## 4-10-5 Time charts

(1) When the power is turned on

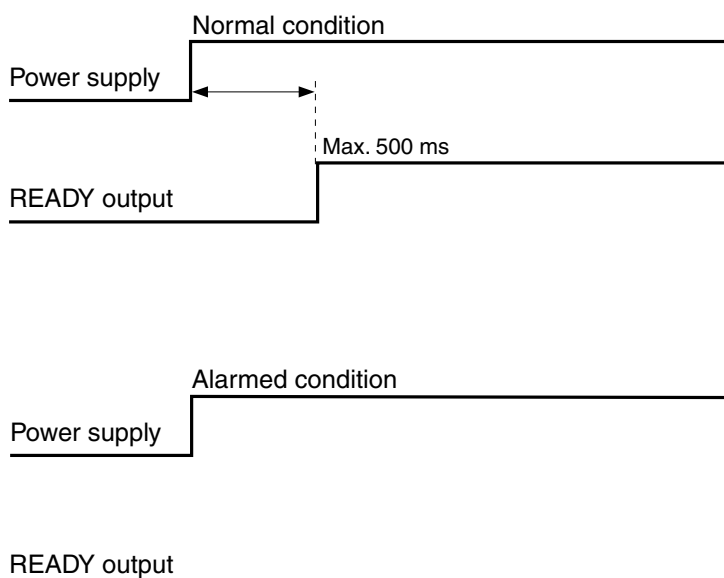

Before inputting a dedicated command, check that READY output is turned ON after the power has been supplied.

If READY output is OFF, even after the specified time has elapsed after the power is turned on, it means that an alarm has occurred.

(2) When an operation command is executed

1. Single solenoid type

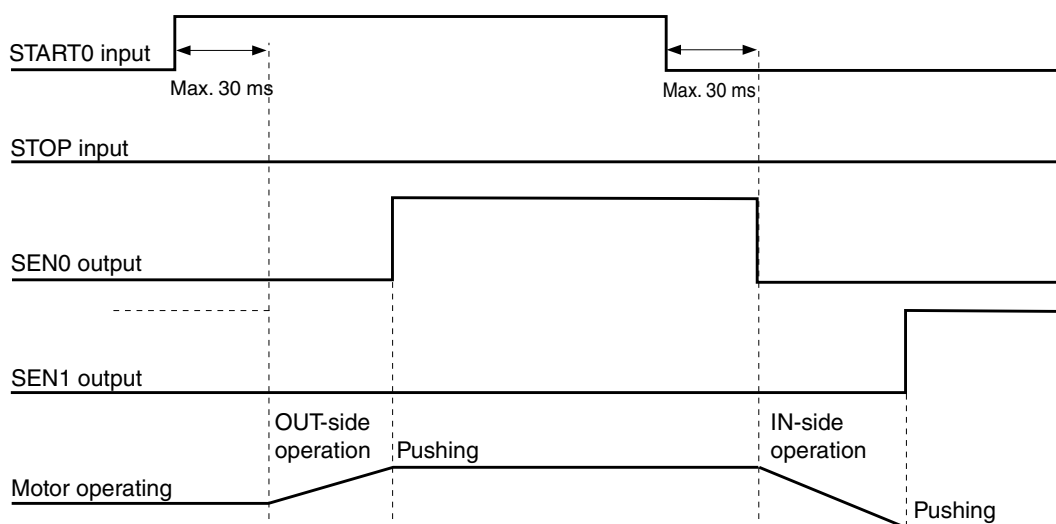

- ① When performing OUT-side pushing operation, keep START0 input ON.
- ② After pushing operation is completed, SEN0 output is ON, and this means that the operation has ended normally.
- ③ When performing IN-side pushing operation, keep START0 input OFF.
- ④ After pushing operation is completed, SEN1 output is ON, and this means that the operation has ended normally.

- Always use pulse inputs for dedicated commands. If an input is left ON, the next command cannot be executed.

## 2. Double solenoid type

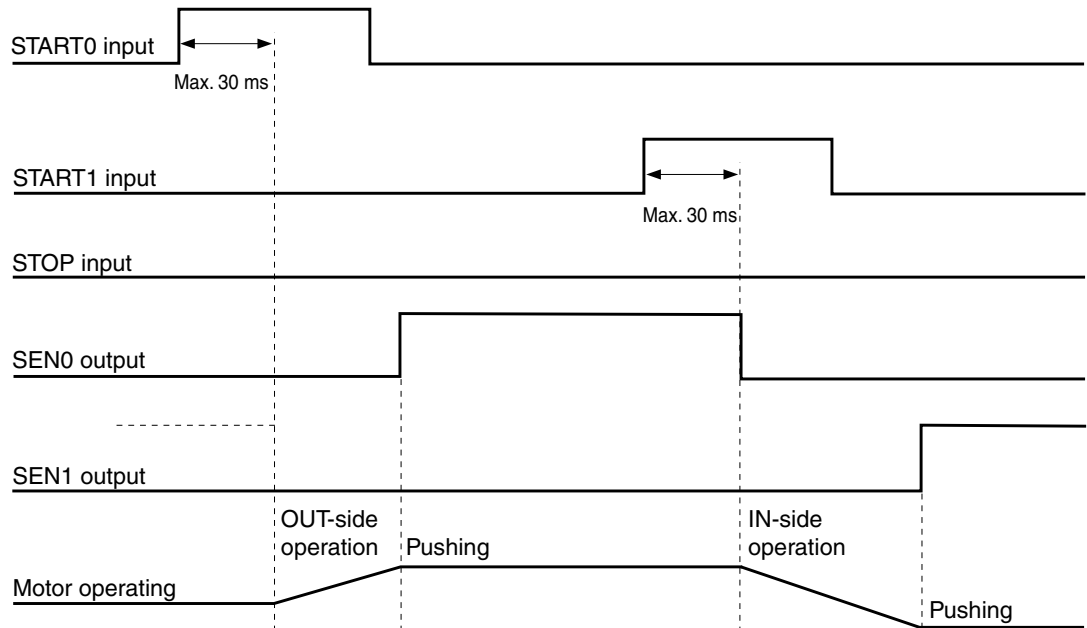

- ① When performing OUT-side pushing operation, input START0 input. When SEN output is ON, SEN output is turned OFF by the rise of a dedicated command input.
- ② When SEN output is ON before input, check that SEN output has turned OFF, and then set the dedicated command input to OFF (open the contact). When SEN output is OFF before input, set the dedicated command input to OFF (open the contact) when 30 ms or more has elapsed after it is set to ON.
- ③ After pushing operation is completed, SEN0 output is ON, and this means that the operation has ended normally.
- ④ When performing IN-side pushing operation, input START1 input. When SEN output is ON, SEN output is turned OFF by the rise of a dedicated command input.
- ⑤ When SEN output is ON before input, check that SEN output has turned OFF, and then set the dedicated command input to OFF (open the contact).
- ⑥ After pushing operation is completed, SEN1 output is ON, and this means that the operation has ended normally.

### (3) When an alarm is cleared

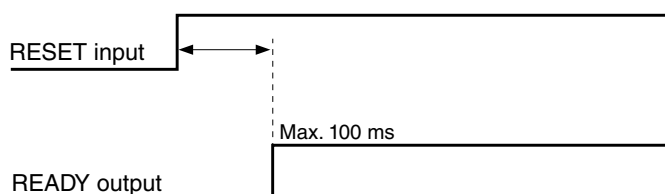

- ① When clearing an alarm, input RESET input.
- ② Check that READY output is ON, and then turn RESET input OFF (open the contact).





# Chapter 5 Troubleshooting

## 5-1 If a problem occurs

When informing Koganei of trouble, please provide information that is as detailed as possible about the following items.

Item	Description (Example)
What?	Controller model Actuator model Power supply
When?	Time of purchase (Serial No.) Period of use, conditions of operation When the power is turned on? 1 hour after the power is turned on
Under what conditions?	During operation The position of the Low Profile Electric Slider when the problem occurred
What happened?	Does not operate Alarm is output
How frequently?	Always occurs Once an hour Cannot be reproduced

## 5-2 Countermeasures for alarms

When READY output is OFF, an alarm is determined to have been issued. In addition, when an alarm is issued, the ALM LED on the front of the controller lights.

When an alarm is issued, turn the power off temporarily, eliminate the cause of the alarm, and then turn on the power again.

## 5-3 Alarm specifications

The transmission format for an alarm message is as follows.

```
NG, <alarm No.> c/r
```

Checking the alarm content

To check the content of the alarm, use a communication cable to connect to a personal computer, and enter the @address, ?EALL or @address, ?ERR command. (Refer to P. 66 and P. 67.)

## 5-3-1 List of alarms

Alarm No.	Alarm	Meaning	Probable cause	Countermeasure
01	Overtimes	<ul style="list-style-type: none"> <li>• Excessive load</li> <li>• Cable disconnected</li> </ul>	<ol style="list-style-type: none"> <li>1) Problem with usage</li> <li>2) Connecting cable is broken or connection is defective</li> <li>3) Mechanical lock</li> <li>4) Pushing beyond the pushing range in U mode</li> <li>5) Too much friction in the actuator unit</li> </ol>	<ol style="list-style-type: none"> <li>1) Decrease the load</li> <li>2) Inspect the cable continuity</li> <li>3) Check for external interference</li> <li>4) Recheck the point data, low speed movement distance, and limit width</li> <li>5) Check whether or not the friction resistance of the moving part of the actuator is too high, and adjust correctly</li> </ol>
04 <sup>Note</sup>	Power supply voltage drop	Power supply (24 VDC) input voltage is too low	Setting mistake for power supply voltage value Power supply is unstable	Raise the power supply voltage Use a stable power supply
05	Power supply voltage high	Input voltage is too high	Power supply	Reduce power supply voltage
06	Cable disconnected	<ul style="list-style-type: none"> <li>• Excessive load during return to origin</li> <li>• Cable disconnected</li> </ul>	<ol style="list-style-type: none"> <li>1) Connecting cable is broken or connection is defective</li> <li>2) Mechanical lock</li> </ol>	<ol style="list-style-type: none"> <li>1) Inspect the cable continuity</li> <li>2) Check for external interference</li> </ol>
08	Point data error	Point data has been corrupted	Power supply was turned off while writing data	Turn on the power supply again, and initialize the point data
09	Parameter data error	Parameter data has been corrupted	Power supply was turned off while writing data	Turn on the power supply again, and initialize the parameter data

Note: Alarm number 4 power supply voltage drop may output the alarm number when the power (24 VDC) is turned off normally also. Furthermore, it is not recorded in the error history.

# Chapter 6 Specifications

## 6-1 Basic specifications of main unit

Item	Model	EW2G10□H	EW2G10□S	EW2G12□H	EW2G12□S	EW2G16□H	EW2G16□S
Motor size	mm	φ10		φ12		φ16	
Type		High speed	High torque	High speed	High torque	High speed	High torque
Motor		Brushless motor					
Maximum thrust <sup>Note 1</sup>	N	10	20	20	40	30	60
Maximum payload (horizontal) <sup>Note 2</sup>	kg	0.6 (0.5)	1 (0.9)	0.8 (0.65)	1.4 (1.25)	1.2 (0.9)	2 (1.7)
Maximum payload (vertical) <sup>Note 2</sup>	kg	0.3 (0.2)	0.5 (0.4)	0.4 (0.25)	0.7 (0.55)	0.6 (0.3)	1 (0.7)
Maximum speed (positioning mode)	mm/s	100	50	100	50	100	50
Maximum speed (pushing mode)	mm/s	20	10	20	10	20	10
Minimum speed	mm/s	10	5	10	5	10	5
Repeatability of positioning accuracy <sup>Note 6</sup> (positioning mode and intermediate stop)	mm	±0.08	±0.06	±0.08	±0.06	±0.08	±0.06
Repeatability of positioning accuracy <sup>Note 3</sup> (pushing mode and when an external stopper is used)	mm	±0.005					
Stroke <sup>Note 4</sup>	mm	10, 30, 50		20, 40, 60, 80		20, 40, 60, 100	
Mass (w/o option, for each stroke)	kg	0.15, 0.2, 0.3		0.3, 0.35, 0.42, 0.5		0.45, 0.6, 0.7, 0.95	
Stroke adjustment range (when an external stopper is used)	mm	OUT-side: -9 to 0 IN-side: -10 to 0		OUT-side: -8 to 0 IN-side: -8 to 0		OUT-side: -7 to 0 IN-side: -5 to 0	
Operating temperature range	°C	5 - 40					
Static rated moment <sup>Note 5</sup>	Mp	N•m	2.8	14.5		20.7	
	My	N•m	3.4	17.2		24.7	
	Mr	N•m	3.8	25.6		43.3	
Applicable controller		EW2C-H-NP, EW2C-H-PN, EW2C-H-CC, EW2C-H-CCD					

Note 1: For details on the pushing force, see the graphs on P. 110.

2: The values in parentheses indicate the values for the fixed table type.

3: To stop the movement with an external stopper, always use pushing mode.

Note 4: Use the product within the stroke range.

5: For details on the moment, refer to P. 108.

6: When the operating terms are the same.

## 6-2 Basic specifications of the controller

### ● Point input type controller (NPN model)

Item	Model	EW2C-H-NP
Control specifications	Motor drive method	Square wave drive
	Control method	Closed loop control <sup>Note 1</sup>
	Operating method	PTP, force control
	Origin detection method	Detection at the stroke end
	Location detection method	Hall IC output
	Minimum setting distance	0.05mm
	Point setting	32 points
	Point input method	Numeric input, teaching input, direct teaching
	Point setting input	5 points
	Control input	3 points (ORG, START, and STOP)
	Control output	4 points (READY, BUSY, HOLD, and INPOS)
	Abnormality detection output	Overtimes, disconnection, incorrect data, system abnormality
	Motor drive cable	Dedicated cables for motor drive output and hall IC input (w/ F.G. and shield)
Hall IC cable		
RS485 communication method	External communications	RS485 1ch (Communication with personal computer or teaching box) Daisy chain available (up to 16 units)
	Communication method	Half duplex
	Synchronization method	Asynchronous method
	Transmission rate	115.2kbps
	Parity bit	Odd number
	Communication distance	Total cable length 100 m or less
Communication cable	Dedicated cable (with twisted shielded cable)	
General specifications	Mass	0.2 kg
	Power supply	DC24V±10% 1.6AMAX (Used also as a power supply for RS485 communication)
	Power supply indication	PWR
	Operating temperature range	0 to 40°C
	Operating humidity range	35 to 85% RH (no condensation)
	Storage temperature range	-10 - 65°C
	Back-up	EEPROM used to maintain setting conditions
	Noise resistance	IEC61000-4-4 level 3
Accessories	I/O cable, power cable	

Note 1: A hall IC is used for step out detection.

### ● Point input type controller (PNP model)

Item	Model	EW2C-H-PN
Control specifications	Motor drive method	Square wave drive
	Control method	Closed loop control <sup>Note 1</sup>
	Operating method	PTP, force control
	Origin detection method	Detection at the stroke end
	Location detection method	Hall IC output
	Minimum setting distance	0.05mm
	Point setting	32 points
	Point input method	Numeric input, teaching input, direct teaching
	Point setting input	5 points
	Control input	3 points (ORG, START, and STOP)
	Control output	4 points (READY, BUSY, HOLD, and INPOS)
	Abnormality detection output	Overtimes, disconnection, incorrect data, system abnormality
	Motor drive cable	Dedicated cables for motor drive output and hall IC input (w/ F.G. and shield)
Hall IC cable		
RS485 communication method	External communications	RS485 1ch (Communication with personal computer or teaching box) Daisy chain available (up to 16 units)
	Communication method	Half duplex
	Synchronization method	Asynchronous method
	Transmission rate	115.2kbps
	Parity bit	Odd number
	Communication distance	Total cable length 100 m or less
	Communication cable	Dedicated cable (with twisted shielded cable)
General specifications	Mass	0.2 kg
	Power supply	DC24V±10% 1.6A MAX (Used also as a power supply for RS485 communication)
	Power supply indication	PWR
	Operating temperature range	0 to 40°C
	Operating humidity range	35 to 85% RH (no condensation)
	Storage temperature range	-10 - 65°C
	Back-up	EEPROM used to maintain setting conditions
	Noise resistance	IEC61000-4-4 level 3
	Accessories	I/O cable, power cable

Note 1: A hall IC is used for step out detection.

## ● CC-Link remote I/O type controller

Item	Model	EW2C-H-CC					
Control specifications	Motor drive method	Square wave drive					
	Control method	Closed loop control <sup>Note 1</sup>					
	Operating method	PTP, force control					
	Origin detection method	Detection at the stroke end					
	Location detection method	Hall IC output					
	Minimum setting distance	0.05mm					
	Point setting	32 points					
	Point input method	Numeric input, teaching input, direct teaching					
	Point setting input	5 points					
	Control input	3 points (ORG, START, and STOP)					
	Control output	4 points (READY, BUSY, HOLD, and INPOS)					
	Abnormality detection output	Overtimes, disconnection, incorrect data, system abnormality					
	Motor drive cable	Dedicated cables for motor drive output and hall IC input (w/ F.G. and shield)					
Hall IC cable							
RS485 communication method	External communications	RS485 1ch (Communication with personal computer or teaching box) Daisy chain available (up to 16 units)					
	Communication method	Half duplex					
	Synchronization method	Asynchronous method					
	Transmission rate	115.2kbps					
	Parity bit	Odd number					
	Communication distance	Total cable length 100 m or less					
	Communication cable	Dedicated cable (with twisted shielded cable)					
General specifications	Mass	0.2 kg					
	Power supply	DC24V±10% 1.6A MAX (Used also as power supplies for CC-Link communication and RS485 communication)					
	Power supply indication	PWR					
	Operating temperature range	0 to 40°C					
	Operating humidity range	35 to 85% RH (no condensation)					
	Storage temperature range	-10 - 65°C					
	Back-up	EEPROM used to maintain setting conditions					
	Noise resistance	IEC61000-4-4 level 3					
Accessories	CC-Link connector, power cable, terminating resistor for CC-Link						
CC-Link communication specifications	Version	Ver.1.10					
	Communication method	Broadcast polling method					
	Synchronization method	Frame synchronization method					
	Transmission method	Bus type (EIA RS485-compliant)					
	Transmission rate	156 k/625 k/2.5 M/5 M/10 Mbps, selectable with a switch (rotary switch)					
	Number of stations occupied	1 remote I/O station					
	Station number setting	1 to 64, selectable with a switch (rotary switch) Selectable with a switch (DIP switch)					
	CLEAR/HOLD	CLEAR: Clears all settings, except the controller connection setting, in case of a CC-Link communication error. HOLD: Maintains the state immediately before the occurrence of the error in case of a CC-Link communication error.					
	Indication	PW, L RUN, SD, RD, L ERR (LED: Red)					
	Transmission distance	Transmission rate bps	156k	625k	2.5M	5M	10M
Total cable length m		1200	900	400	160	100	
Communication cable	Ver.1.10-compatible CC-Link dedicated cable						
Terminating resistance	110 Ω (when a Ver.1.10-compatible CC-Link dedicated cable is used)						

Note 1: A hall IC is used for step out detection.

## ● CC-Link remote device type controller

Item	Model	EW2C-H-CCD					
Control specifications	Motor drive method	Square wave drive					
	Control method	Closed loop control <sup>Note 1</sup>					
	Operating method	PTP, force control					
	Origin detection method	Detection at the stroke end					
	Location detection method	Hall IC output					
	Minimum setting distance	0.05mm					
	Point setting	32 points					
	Point input method	Numeric input, teaching input, direct teaching					
	Point setting input	5 points					
	Abnormality detection output	Overtimes, disconnection, incorrect data, system abnormality					
	Motor drive cable	Dedicated cables for motor drive output and hall IC input					
	Hall IC cable	(w/ F.G. and shield)					
RS485 Communication method	External communications	RS485 1ch (Communication with personal computer or teaching box) Daisy chain available (up to 16 units)					
	Communication method	Half duplex					
	Synchronization method	Asynchronous method					
	Transmission rate	115.2kbps					
	Parity bit	Odd number					
	Communication distance	Total cable length 100 m or less					
	Communication cable	Dedicated cable (with twisted shielded cable)					
General specifications	Mass	0.2 kg					
	Power supply	DC24V±10% 1.6A MAX (Used also as power supplies for CC-Link communication and RS485 communication)					
	Power supply indication	PWR					
	Operating temperature range	0 to 40°C					
	Operating humidity range	35 to 85% RH (no condensation)					
	Storage temperature range	-10 to 65°C					
	Back-up	FRAM used to maintain setting conditions					
	Noise resistance	IEC61000-4-4 level 3					
Accessories	CC-Link connector, power cable, CC-Link terminating resistor						
CC-Link communication specifications	Version	Ver.1.10					
	Communication method	Broadcast polling method					
	Synchronization method	Frame synchronization method					
	Transmission method	Bus type (EIA RS485-compliant)					
	Transmission rate	156 k/625 k/2.5 M/5 M/10 Mbps, selectable with a switch (rotary switch)					
	Number of stations occupied	Remote device stations 1 station/2 stations/4 stations					
	Maximum number of units that can be connected	When one station is occupied: 42 units When two stations are occupied: 32 units When four stations are occupied: 16 units Selectable with a switch (rotary switch)					
	Station number setting	When one station is occupied: 1 to 64 When two stations are occupied: 1 to 63 When four stations are occupied: 1 to 61 Selectable with a switch (DIP switch)					
	CLEAR/HOLD	CLEAR: Clears all settings, except the controller connection setting, in case of a CC-Link communication error. HOLD: Maintains the state immediately before the occurrence of the error in case of a CC-Link communication error.					
	Indication	PW, L RUN, SD, RD, L ERR (LED: Blue)					
	Transmission distance	Transmission rate bps	156k	625k	2.5M	5M	10M
		Total cable length m	1200	900	400	160	100
	Communication cable	Ver.1.10-compatible CC-Link dedicated cable					
Terminating resistance	110 Ω (when a Ver.1.10-compatible CC-Link dedicated cable is used)						

Note 1: A hall IC is used for step out detection.





# Chapter 7 Outline Drawings

## 7-1 Main unit outline drawings (Unit: mm)

### EW2G10 (standard type)

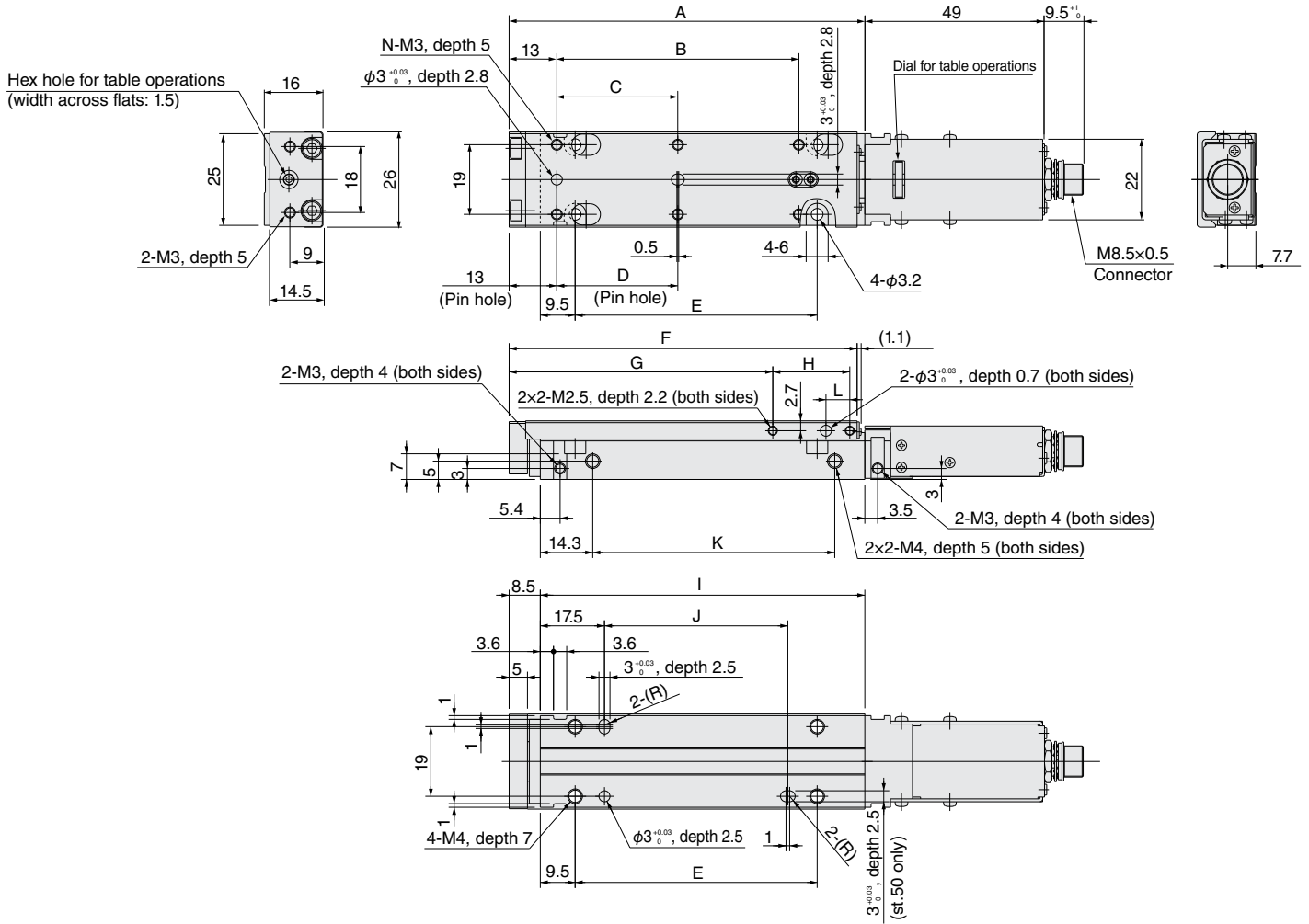

Stroke	A	B	C	D	E	F	G	H	I	J	K	L	N
10	47	-	16	10	16	44.9	31.9	11	38.5	-	16	6.5	4
30	67	-	36	30	36	64.9	51.9	11	58.5	-	36	6.5	4
50	97	66	33	33	66	94.9	71.9	21	88.5	50	66	7	6

Cable direction: For -1, -2, -3, or -4 (view from arrow R)

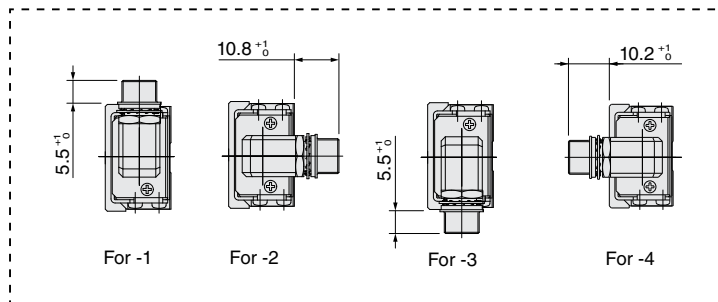
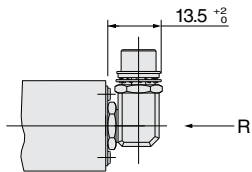

**EW2G10C (Measure against foreign objects: Cover type)**

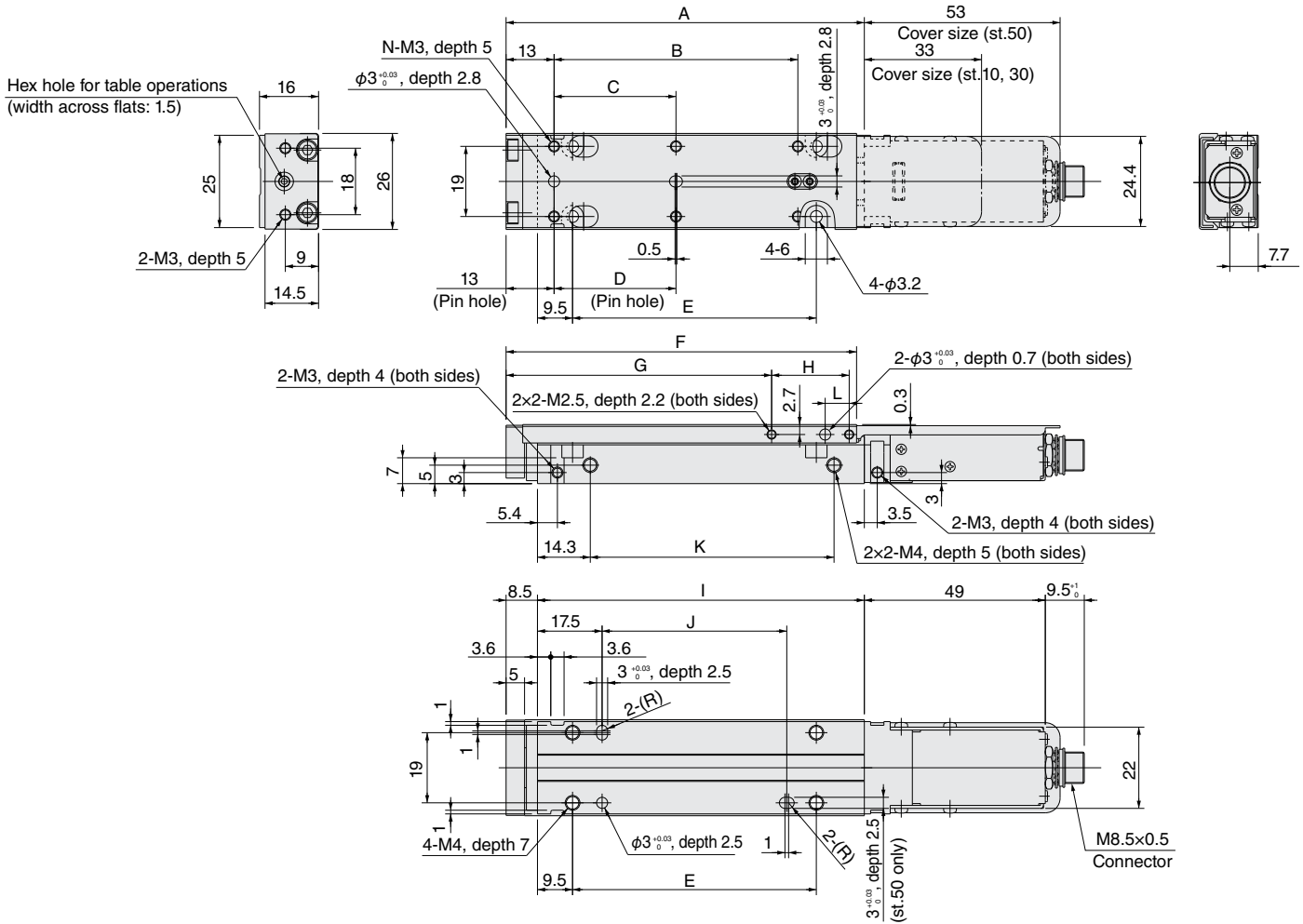

Stroke	A	B	C	D	E	F	G	H	I	J	K	L	N
10	47	-	16	10	16	44.9	31.9	11	38.5	-	16	6.5	4
30	67	-	36	30	36	64.9	51.9	11	58.5	-	36	6.5	4
50	97	66	33	33	66	94.9	71.9	21	88.5	50	66	7	6

Cable direction: For -1, -2, or -3  
(view from arrow R)

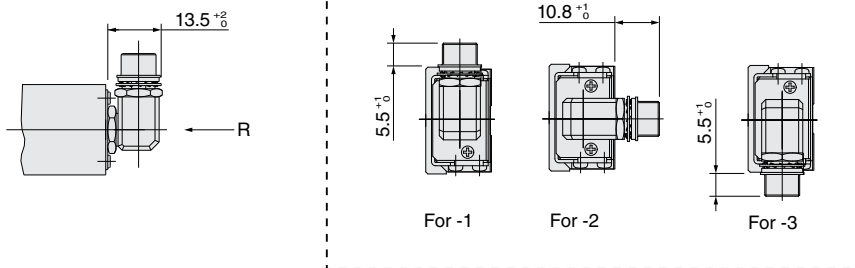

### EW2G10R (Measure against foreign objects: Fixed table type)

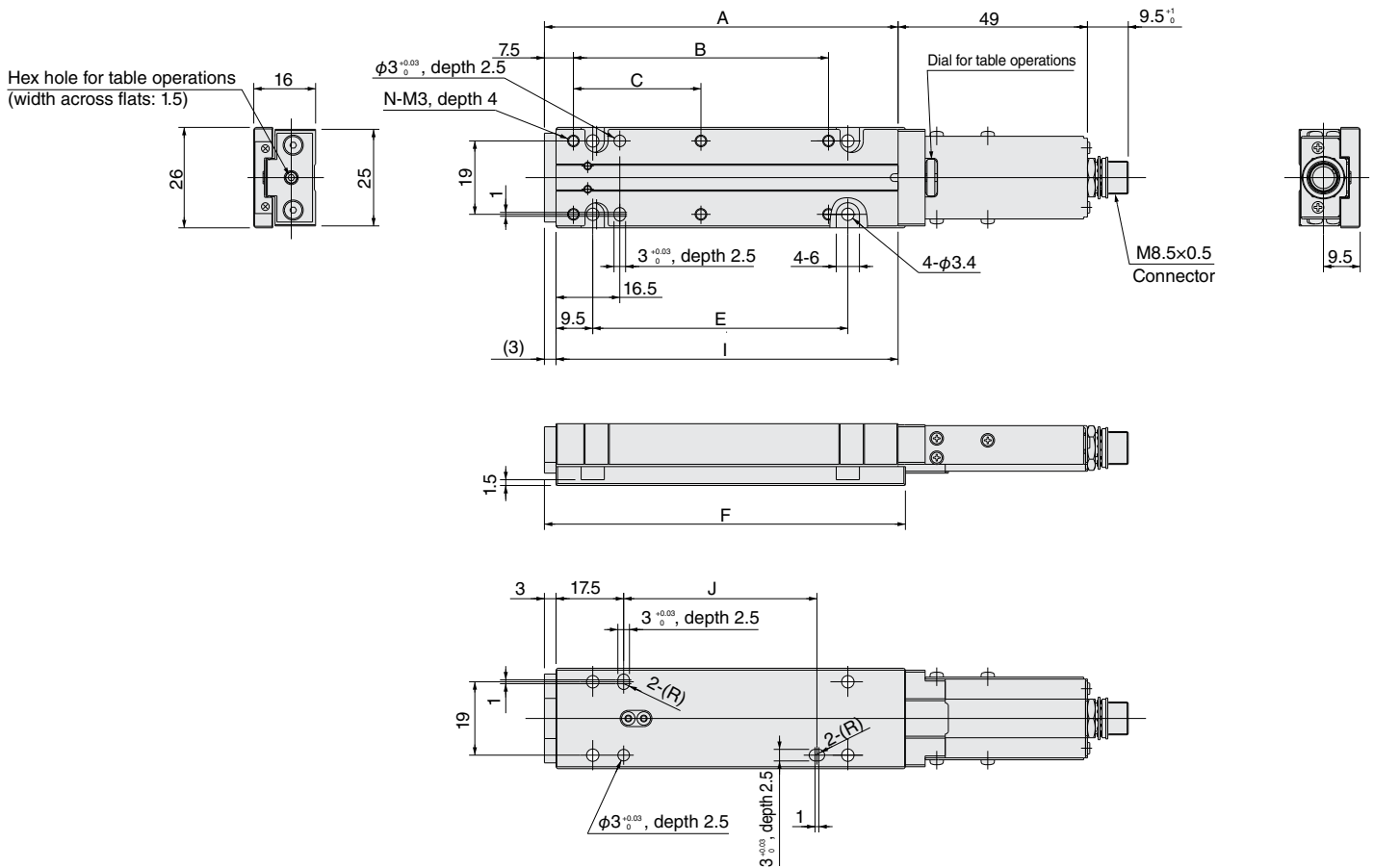

Stroke	A	B	C	E	F	I	J	N
10	41.5	-	16	16	43.4	38.5	-	4
30	61.5	-	36	36	63.4	58.5	-	4
50	91.5	66	33	66	93.4	88.5	50	6

● Dimensions with the connecting cable mounted and dimensions with the cable bent (reference values)

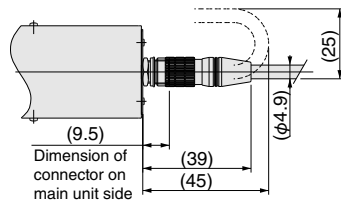

Note: As is the case with different cable directions, the dimensions with the connecting cable mounted are longer than those with the connecting cable not mounted by 30 mm or so.

**EW2G10□-Stroke-MS□ (w/ stroke adjustment mechanism and bracket set)**

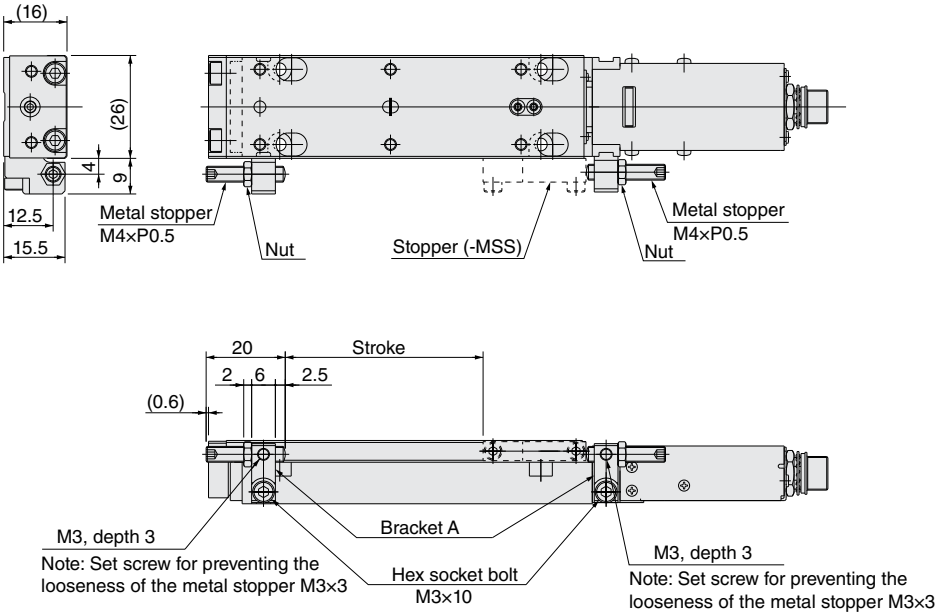

Remarks 1: These dimensions are those with the stroke adjustment mechanism installed. The stroke adjustment mechanism components are provided separately.  
2: The stroke adjustment mechanism components may be installed on the opposite side.

**EW2G10□-Stroke-MS□ (w/ stroke adjustment mechanism and stopper set)**

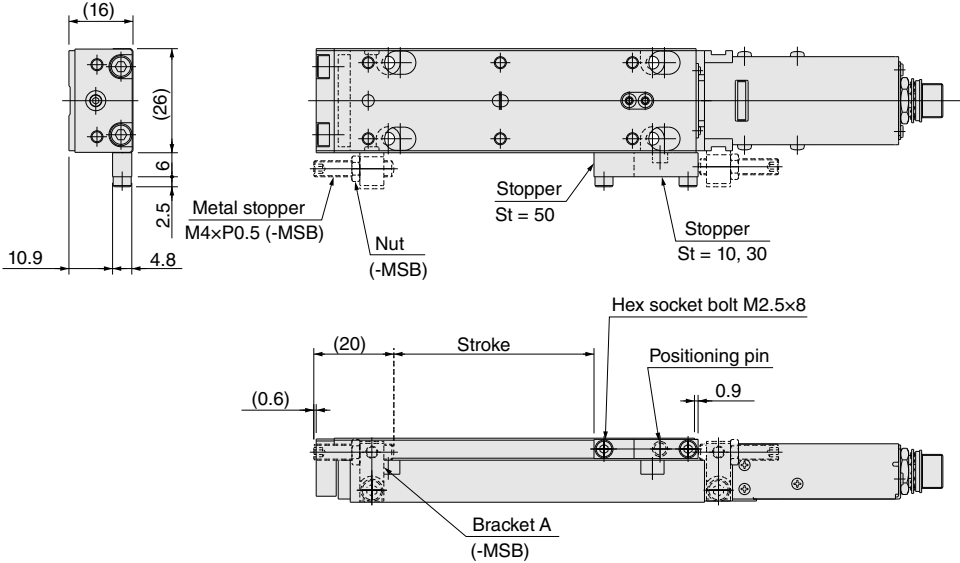

Remarks 1: These dimensions are those with the stroke adjustment mechanism installed. The stroke adjustment mechanism components are provided separately.  
2: The stroke adjustment mechanism components may be installed on the opposite side.

### Vertical bracket (additional parts)

#### ●EW2G-BK1-10

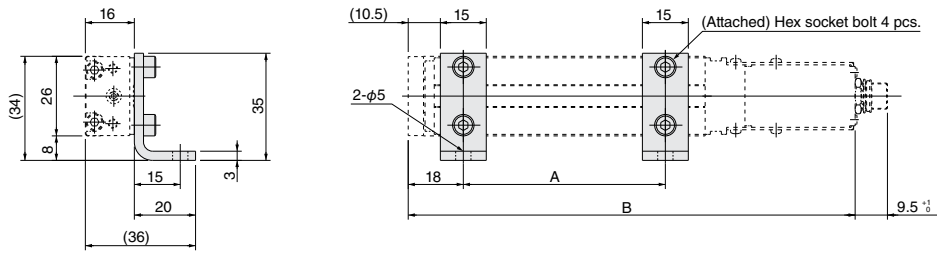

Stroke	A	B
10	16	96
30	36	116
50	66	146

#### ●EW2G-BK2-10

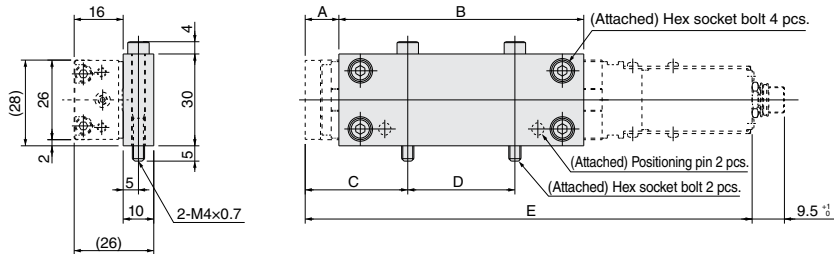

Stroke	A	B	C	D	E
20	3.5	45	8.5	35	96
40	3.5	65	8.5	55	116
60	11	80	33.5	35	146

#### ●EW2G-BK3-10

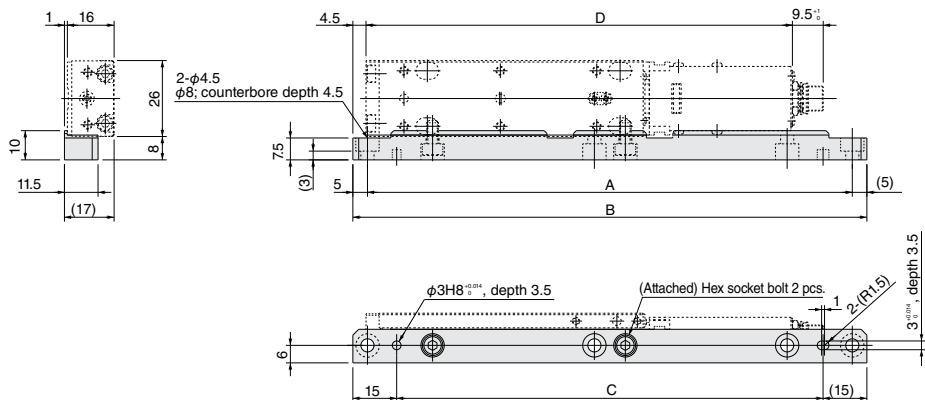

Stroke	A	B	C	D
20	116	126	96	96
40	136	146	116	116
60	166	176	146	146

\* May be installed symmetrically.



### EW2G12C (Measure against foreign objects: Cover type)

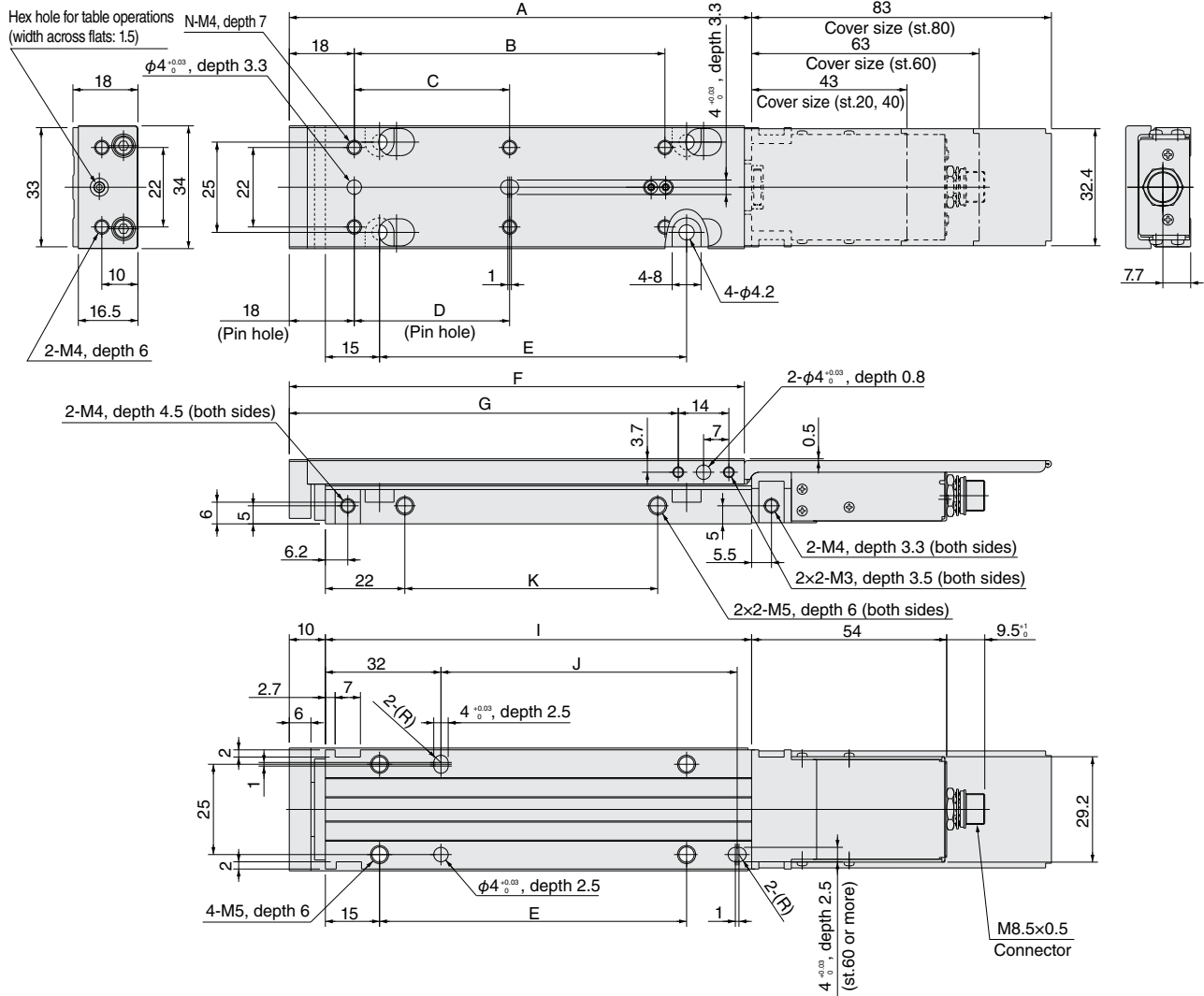

Stroke	A	B	C	D	E	F	G	I	J	K	N
20	68	-	26	16	25	66	47.7	58	-	25	4
40	88	-	46	36	45	86	67.7	78	-	25	4
60	108	66	33	33	65	106	87.7	98	62	50	6
80	128	86	43	43	85	126	107.7	118	82	70	6

Cable direction: For -1, -2, or -3  
(view from arrow R)

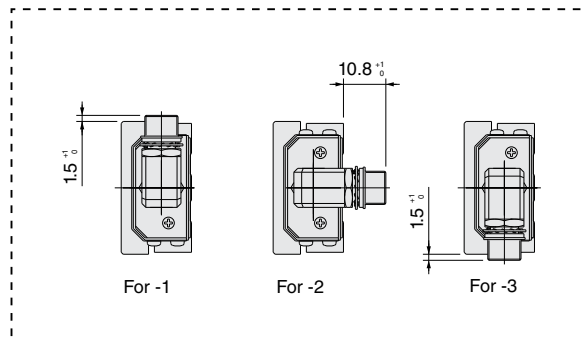
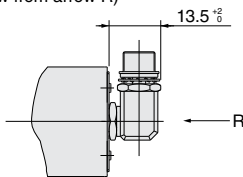

### EW2G12R (Measure against foreign objects: Fixed table type)

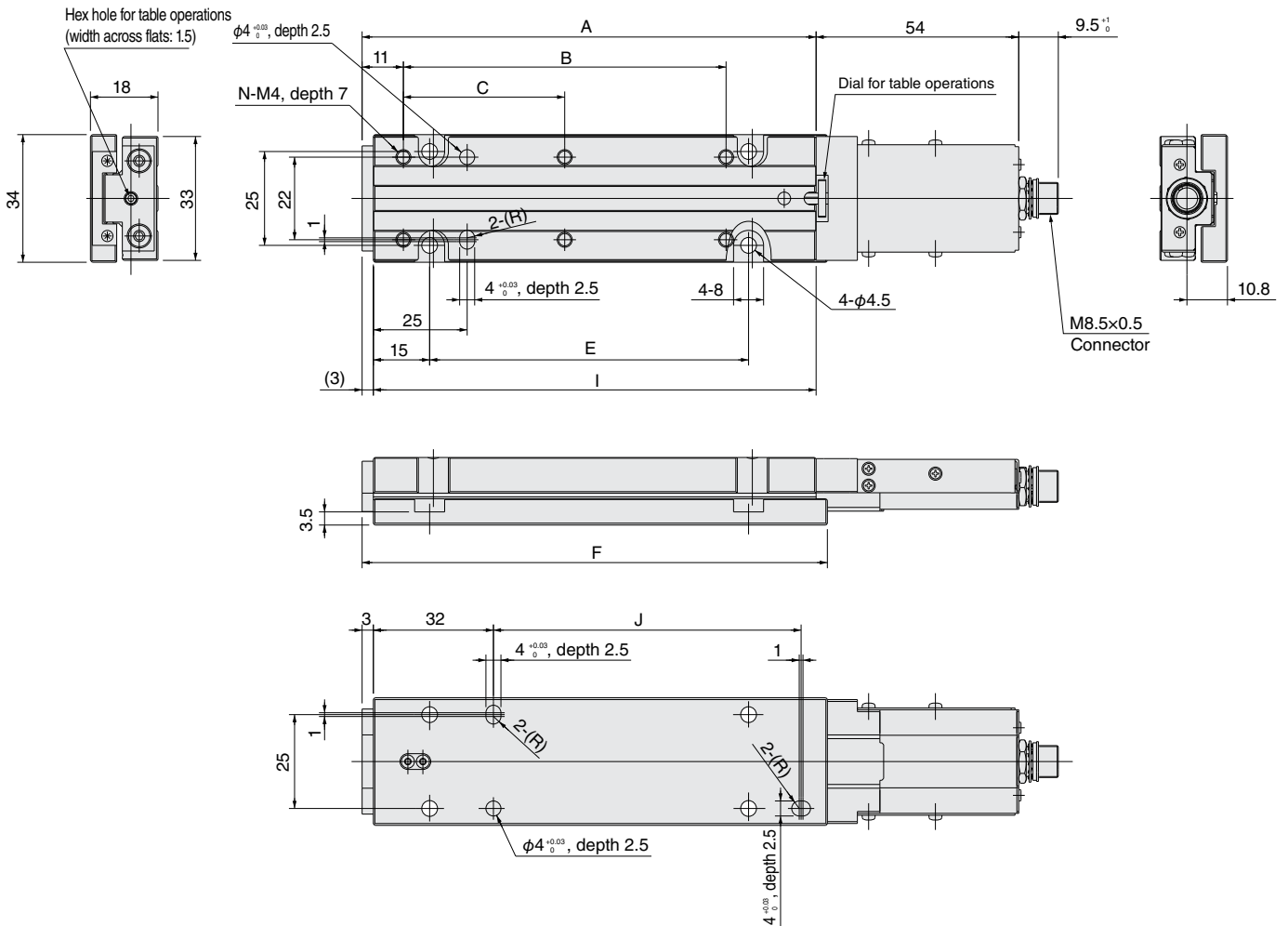

Stroke	A	B	C	E	F	I	J	N
20	61	-	26	25	64	58	-	4
40	81	-	46	45	84	78	-	4
60	101	66	33	65	104	98	62	6
80	121	86	43	85	124	118	82	6

● Dimensions with the connecting cable mounted and dimensions with the cable bent (reference values)

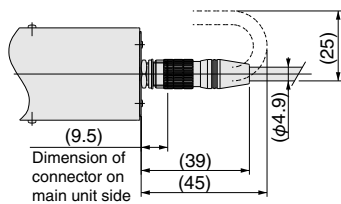

Note: As is the case with different cable directions, the dimensions with the connecting cable mounted are longer than those with the connecting cable not mounted by 30 mm or so.



**EW2G12□-Stroke-MS□ (w/ stroke adjustment mechanism and bracket set)**

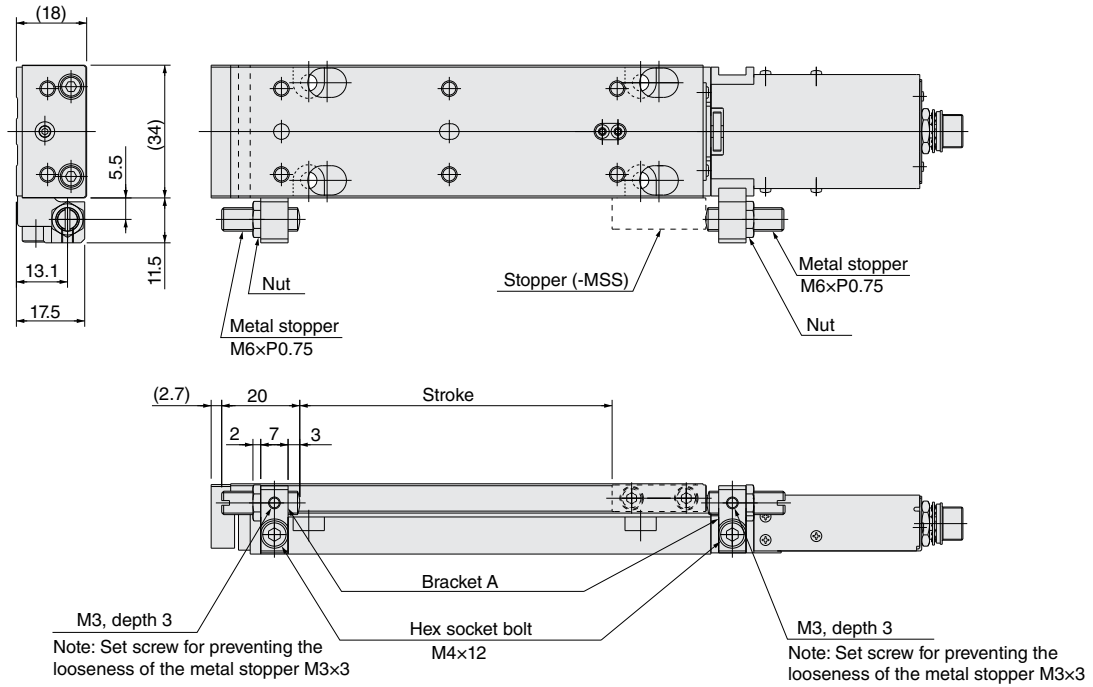

Remarks 1: These dimensions are those with the stroke adjustment mechanism installed. The stroke adjustment mechanism components are provided separately.  
 2: The stroke adjustment mechanism components may be installed on the opposite side.

**EW2G12□-Stroke-MS□ (w/ stroke adjustment mechanism and stopper set)**

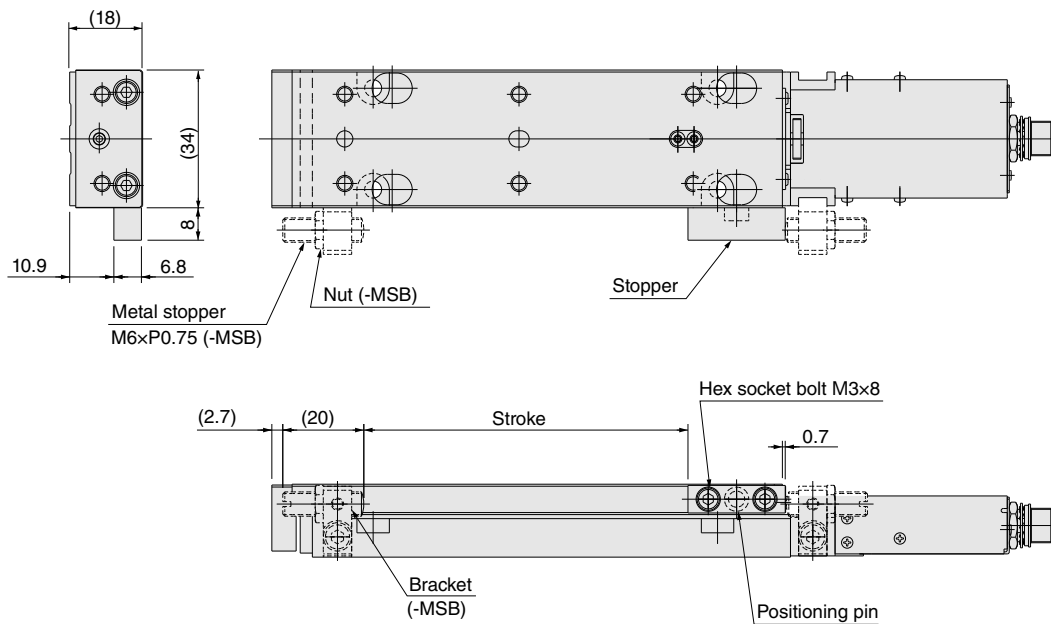

Remarks 1: These dimensions are those with the stroke adjustment mechanism installed. The stroke adjustment mechanism components are provided separately.  
 2: The stroke adjustment mechanism components may be installed on the opposite side.

**Vertical bracket (additional parts)**

● **EW2G-BK1-12**

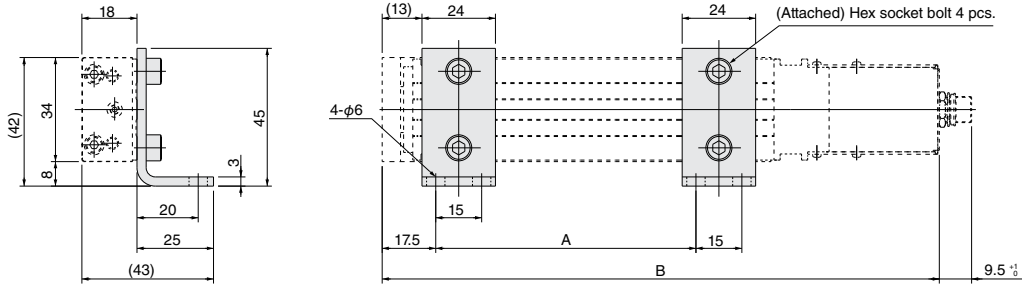

Stroke	A	B
20	25	122
40	45	142
60	65	162
80	85	182

● **EW2G-BK2-12**

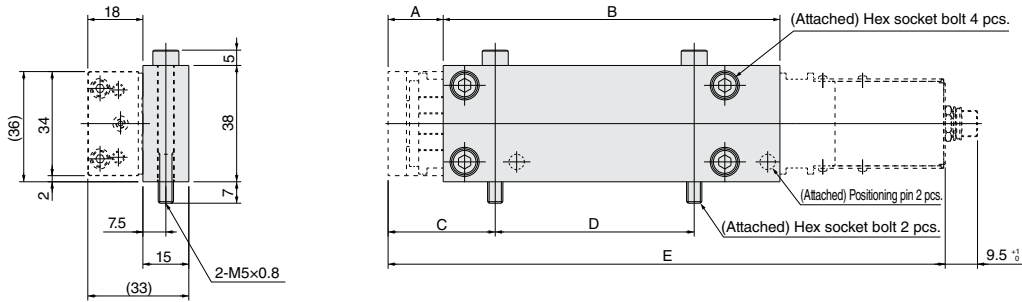

Stroke	A	B	C	D	E
20	10	55	15	45	122
40	17.5	60	35	25	142
60	18	90	35	45	162
80	18	110	35	65	182

● **EW2G-BK3-12**

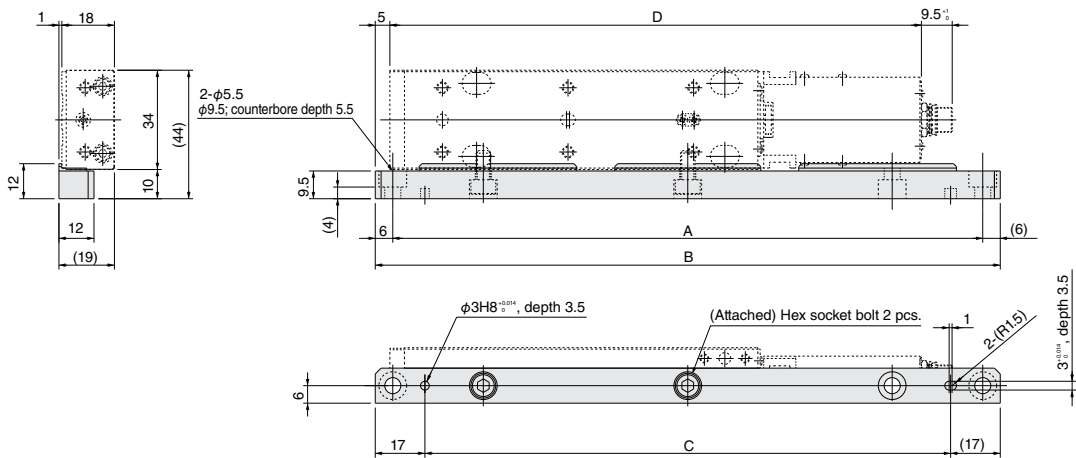

Stroke	A	B	C	D
20	142	154	120	122
40	162	174	140	142
60	182	194	160	162
80	202	214	180	182

\* May be installed symmetrically.

### EW2G16 (standard type)

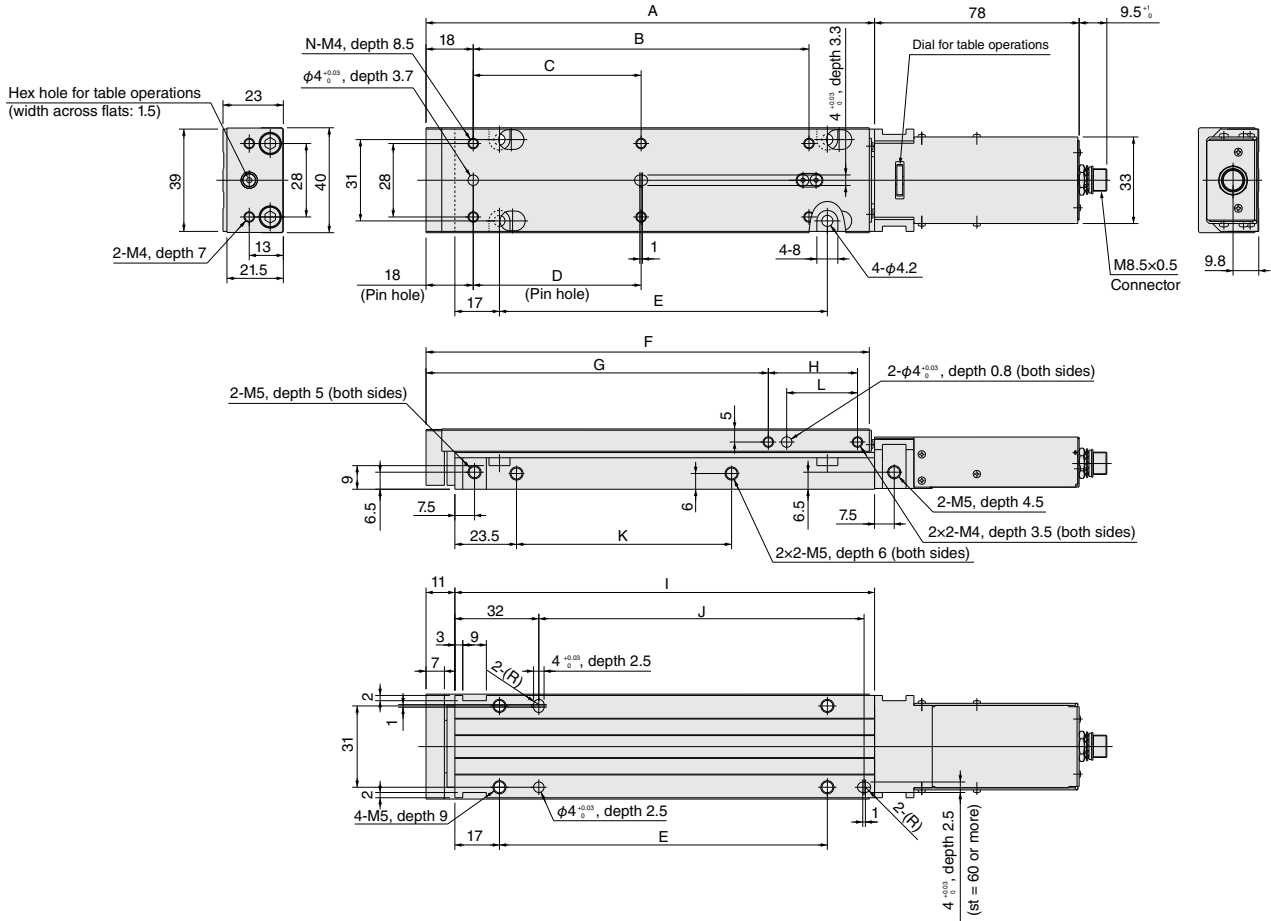

Stroke	A	B	C	D	E	F	G	H	I	J	K	L	N
20	71	-	28	18	25	69	50.5	14	60	-	12	7	4
40	91	-	48	38	45	89	70.5	14	80	-	32	7	4
60	111	68	34	34	65	109	90.5	14	100	64	42	7	6
100	171	128	64	64	125	169	130.5	34	160	124	82	27	6

Cable direction: For -1, -2, -3, or -4 (view from arrow R)

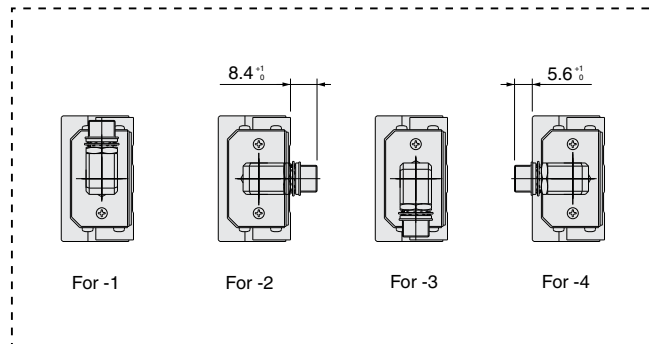
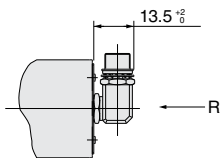

**EW2G16C (Measure against foreign objects: Cover type)**

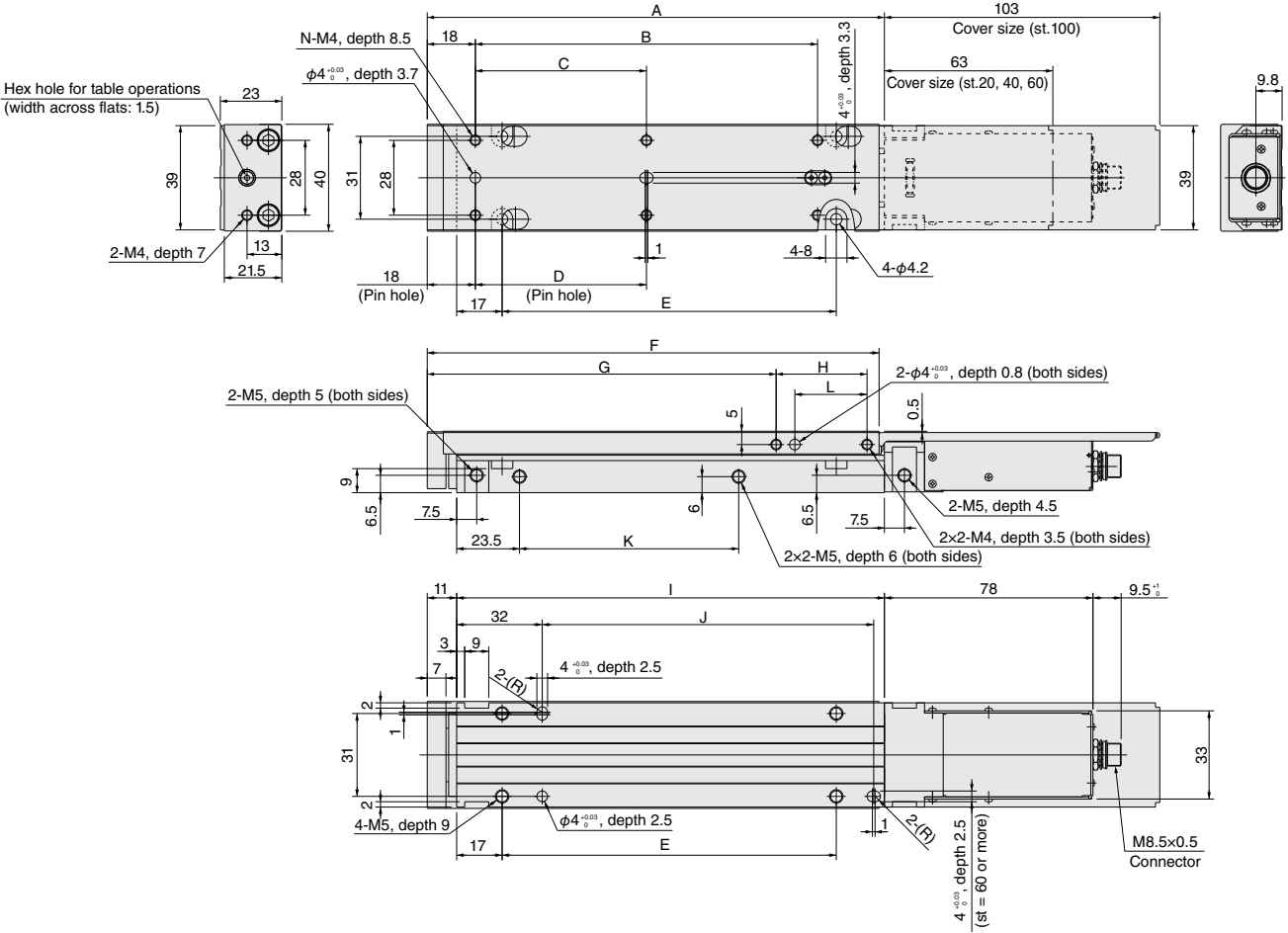

Stroke	A	B	C	D	E	F	G	H	I	J	K	L	N
20	71	-	28	18	25	69	50.5	14	60	-	12	7	4
40	91	-	48	38	45	89	70.5	14	80	-	32	7	4
60	111	68	34	34	65	109	90.5	14	100	64	42	7	6
100	171	128	64	64	125	169	130.5	34	160	124	82	27	6

Cable direction: For -1, -2, or -3 (view from arrow R)

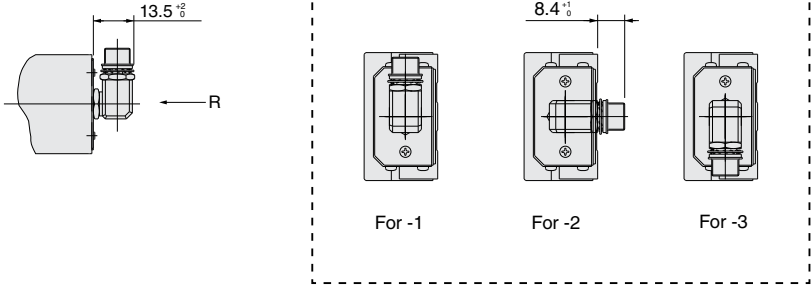

### EW2G16R (Measure against foreign objects: Fixed table type)

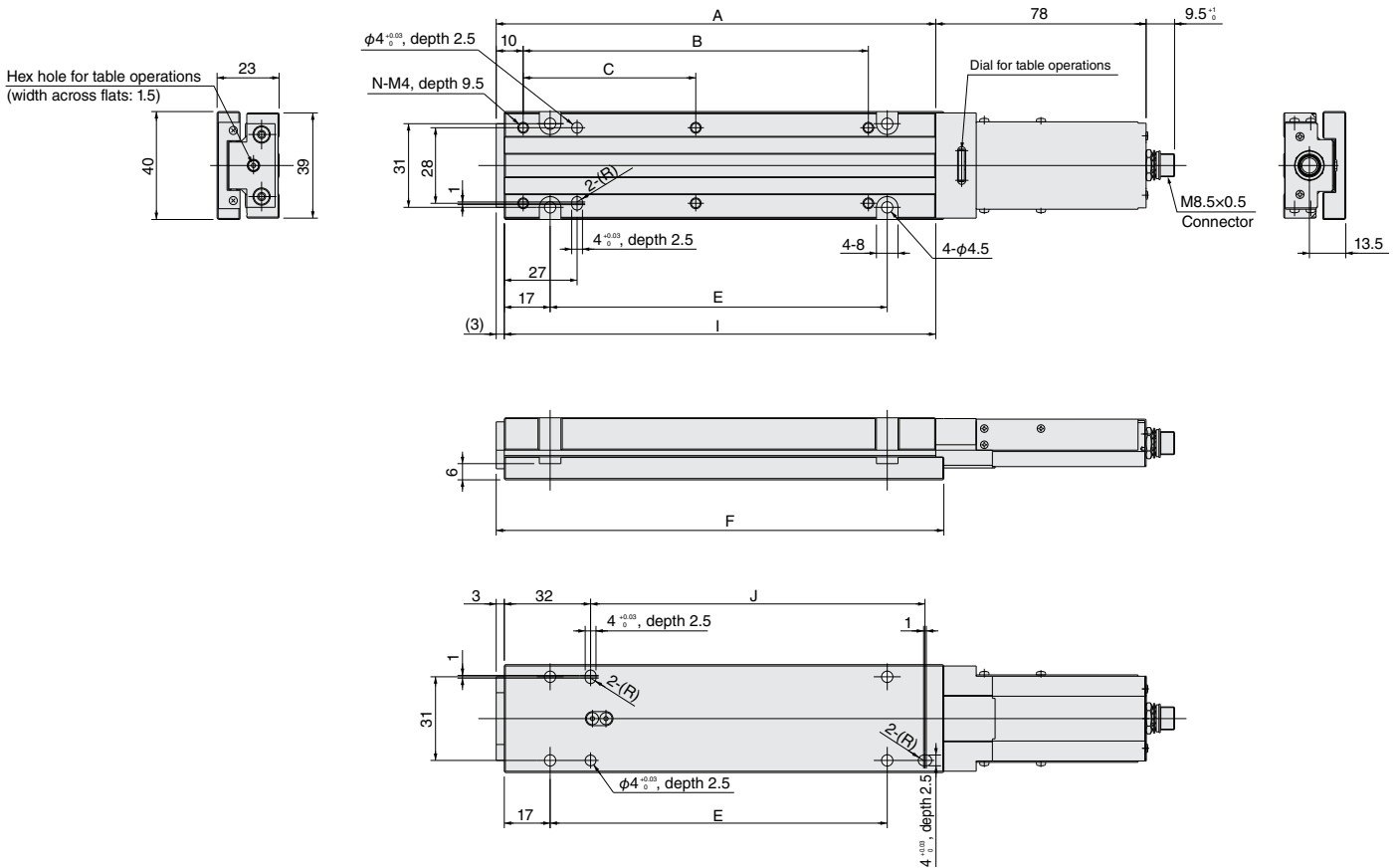

Stroke	A	B	C	E	F	I	J	N
20	63	-	28	25	66	60	-	4
40	83	-	48	45	86	80	-	4
60	103	68	34	65	106	100	64	6
100	163	128	64	125	166	160	124	6

● Dimensions with the connecting cable mounted and dimensions with the cable bent (reference values)

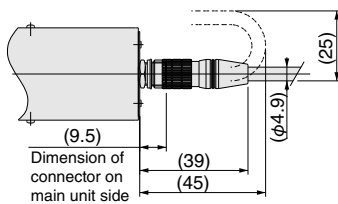

Note: As is the case with different cable directions, the dimensions with the connecting cable mounted are longer than those with the connecting cable not mounted by 30 mm or so.

**EW2G16□-Stroke-MS□ (w/ stroke adjustment mechanism and bracket set)**

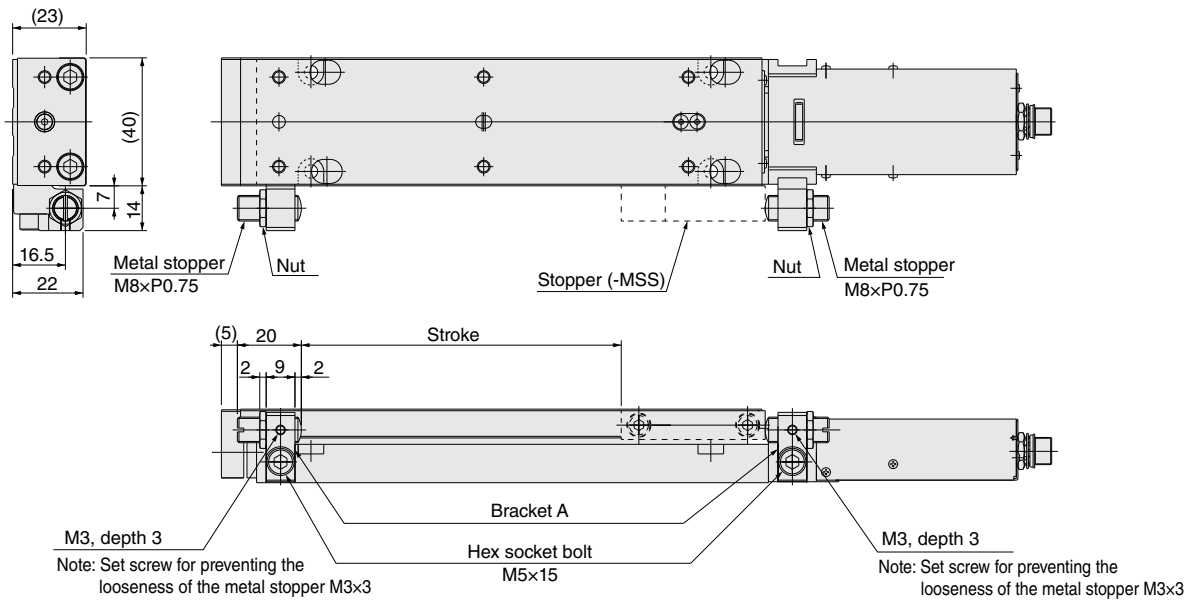

Remarks 1: These dimensions are those with the stroke adjustment mechanism installed. The stroke adjustment mechanism components are provided separately.  
 2: The stroke adjustment mechanism components may be installed on the opposite side.

**EW2G16□-Stroke-MS□ (w/ stroke adjustment mechanism and stopper set)**

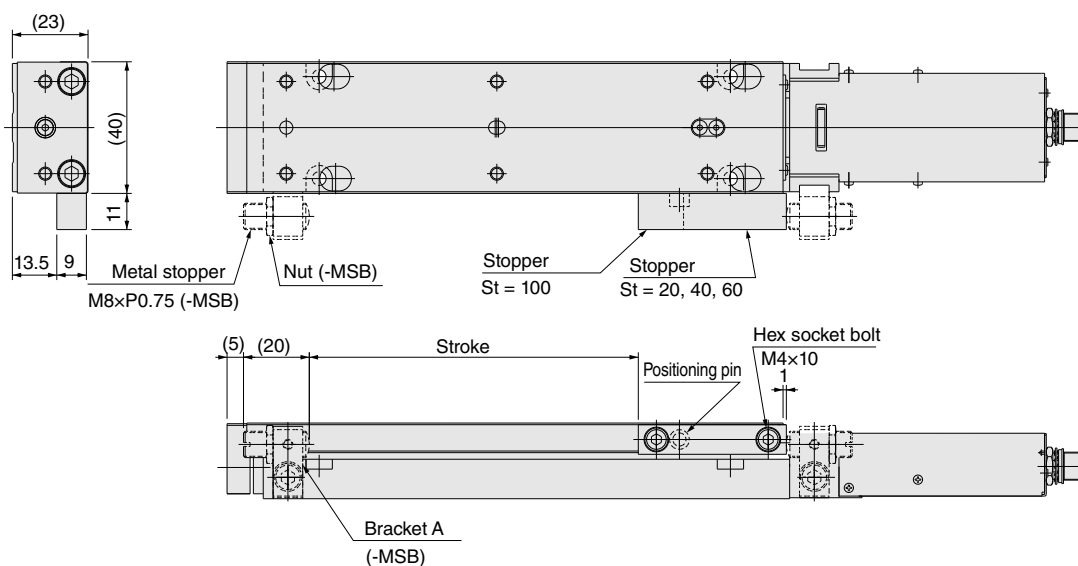

Remarks 1: These dimensions are those with the stroke adjustment mechanism installed. The stroke adjustment mechanism components are provided separately.  
 2: The stroke adjustment mechanism components may be installed on the opposite side.

**Vertical bracket (additional parts)**

● **EW2G-BK1-16**

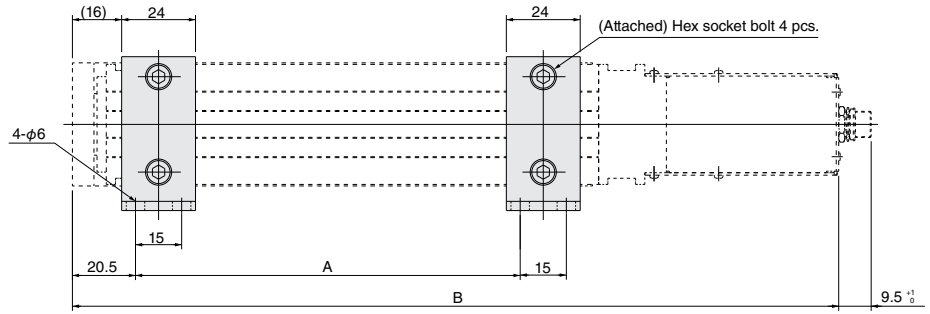
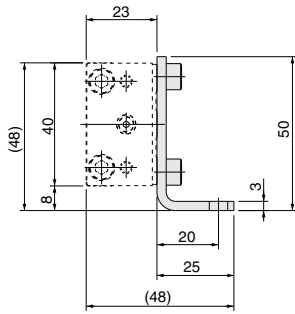

Stroke	A	B
20	25	149
40	45	169
60	65	189
100	125	249

● **EW2G-BK2-16**

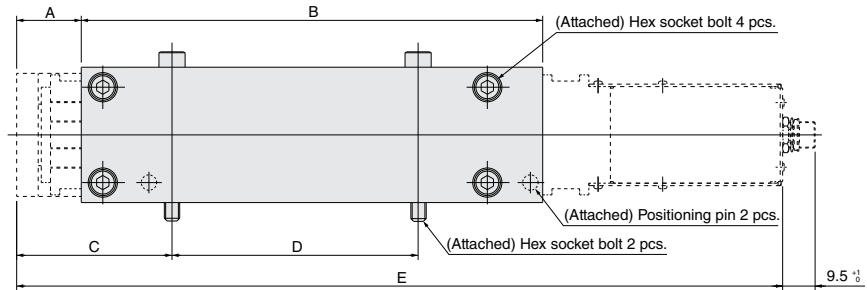
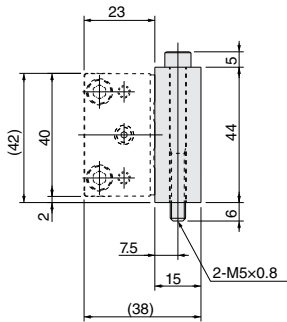

Stroke	A	B	C	D	E
20	13	55	18	45	149
40	20.5	60	37.5	26	169
60	21	90	37.5	46	189
100	21	150	50.5	80	249

● **EW2G-BK3-16**

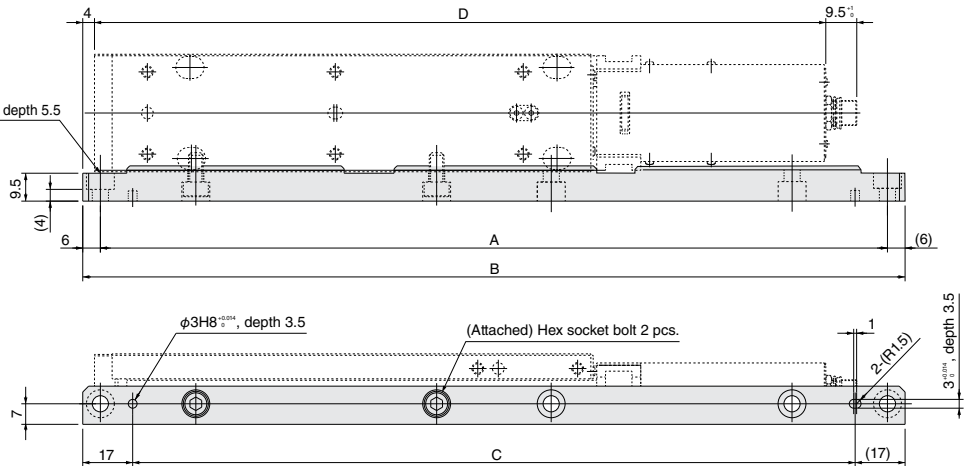
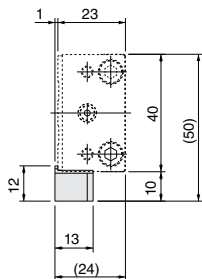

Stroke	A	B	C	D
20	168	180	146	149
40	188	200	166	169
60	208	220	186	189
100	268	280	246	249

\* May be installed symmetrically.





## 7-2 Controller outline drawings (Unit: mm)

(Point input type)

**EW2C-H-**  -  **DIN rail mounting plate**  
**Blank:** Not equipped  
**DP:** Equipped

Controller type

**NP:** Point input type (NPN model)  
**PN:** Point input type (PNP model)

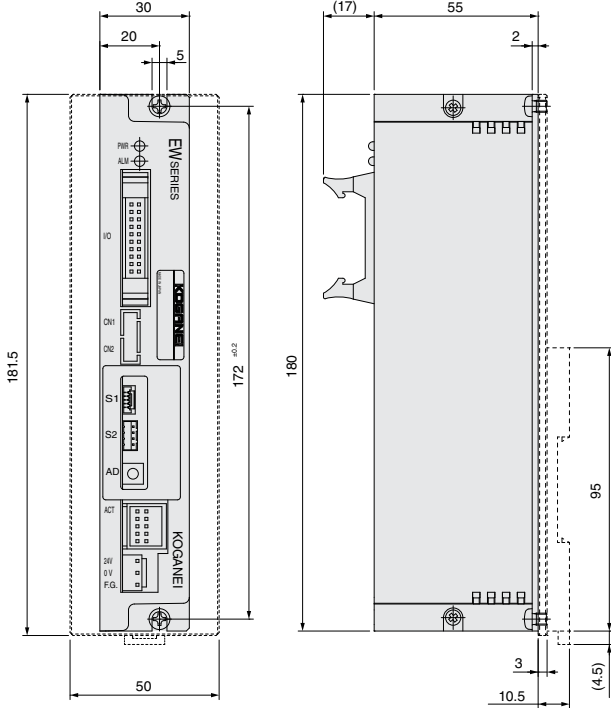

\* The dotted lines indicate the dimensions of the DIN rail mounting plate.

(CC-Link type)

**EW2C-H-**  -  **DIN rail mounting plate**  
**Blank:** w/o mounting plate  
**DP:** w/ mounting plate

Controller type

**CC:** CC-Link remote I/O type  
**CCD:** CC-Link remote device type

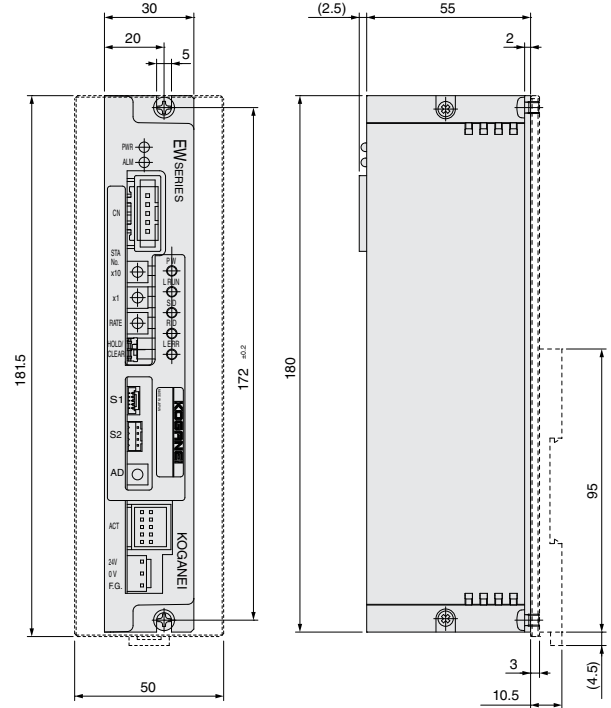

\* The dotted lines indicate the dimensions of the DIN rail mounting plate.

(DIN rail mounting plate)

**EW2DP**

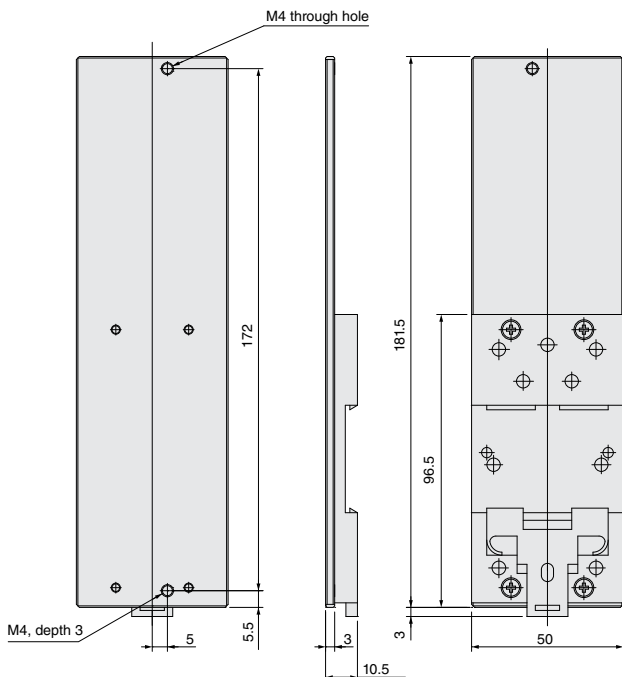
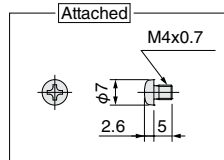

(CC-Link connector)

**EW2CC**

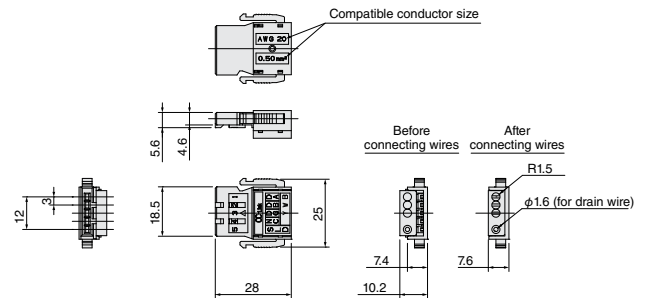

\* This connector is compatible with a CC-Link communication cable.

(CC-Link branch connector)

**EW2CY**

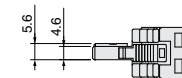
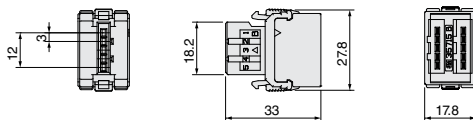

\* This connector is compatible with the CC-Link communication connector (Model: EW2CC).

(CC-Link terminating resistor)

**EW2FC**

Resistor 110 Ω

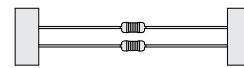

Resistor 130 Ω

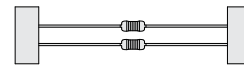

### 7-3 Outline drawings for additional parts (Unit: mm)

- For connection

**EW2KA-**

3L: 3m  
5L: 5m

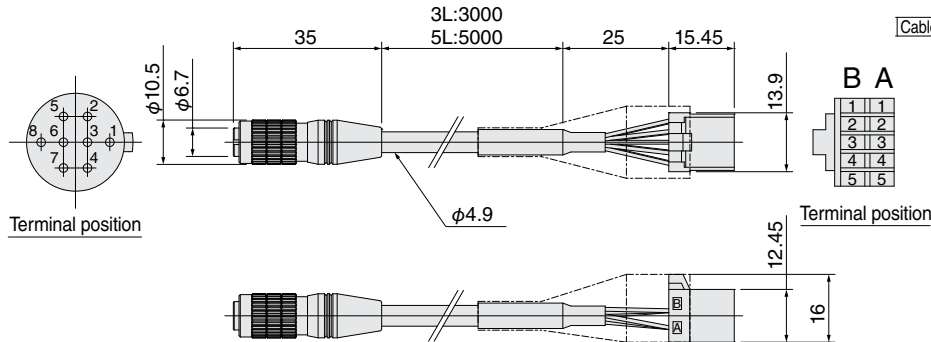

Main unit side connector

NO.	Name	Color
1	U	Green
2	V	Brown
3	W	Yellow
4	Vcc	Orange
5	HU	White
6	HV	Red
7	HW	Black
8	GND	Blue

Controller side connector

NO.	Name	Color
A1	U	Green
B1	V	Brown
A2	W	Yellow
B2	FG	White
A3	Vcc	Orange
B3	GND	Blue
A4	HU	White
B4	HV	Red
A5	HW	Black
B5	N.C.	-

Cable shield

B A

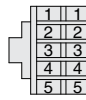

Terminal position

- For power supply

**EW2KP**

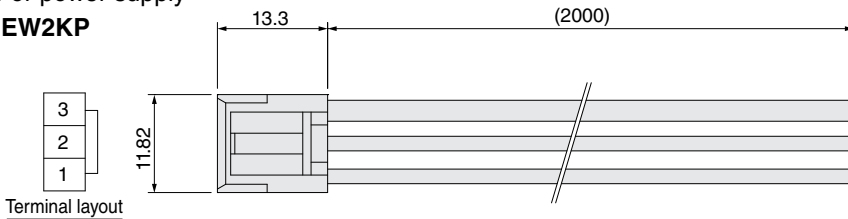

Power connector terminal layout

NO.	Name	Color
1	24V	Red
2	GND	Blue
3	F.G.	Green

- For I/O

**EW2KI**

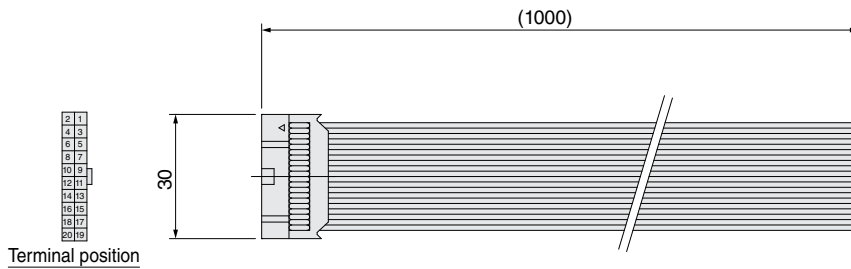

I/O Connector terminal layout

NO.	Name	Color
1	POS0	Brown
2	POS1	Red
3	POS2	Orange
4	POS3	Yellow
5	POS4	Green
6	START	Blue
7	STOP	Purple
8	ORG	Gray
9	RDY	White
10	BUSY	Black
11	INPOS	Brown
12	HOLD	Red
13	24V IN	Orange
14	N.C.	Yellow
15	24G	Green
16	24V IN	Blue
17	N.C.	Purple
18	24V	Gray
19	F.G.	White
20	F.G.	Black

- For daisy chain (for RS485 communication)

**EW2KD-**

008L: 80mm  
1L: 1m  
3L: 3m

Connector terminal layout (controller top)

NO.	Name	Color
1	A	Brown
2	B	Blue
3	GND	Black
4		

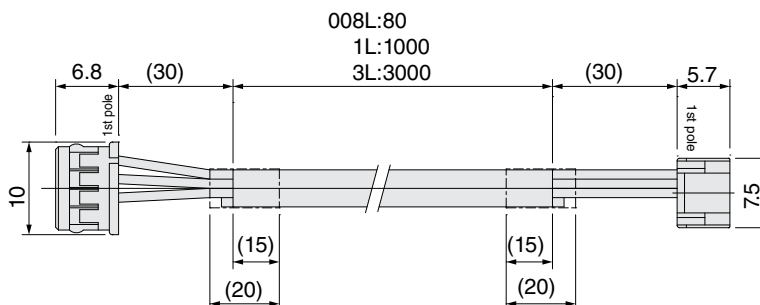

Cable layout chart

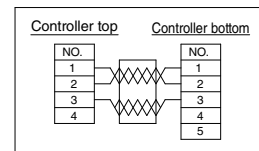

Connector terminal layout (controller bottom)

NO.	Name	Color
1	A	Brown
2	B	Blue
3	GND	Black
4		
5		

• For communication

**EW2KN** -

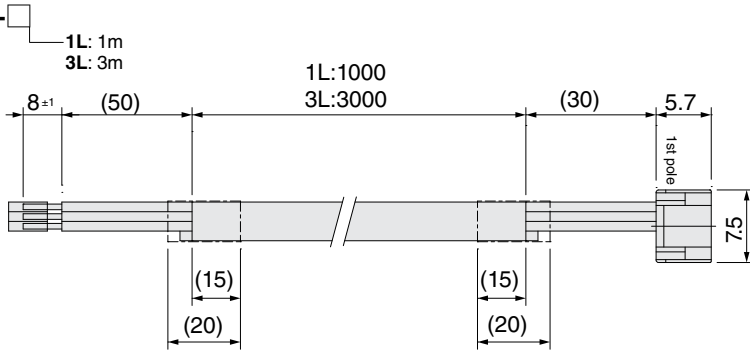

Cable layout chart

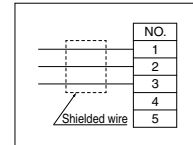

Connector terminal layout (controller bottom)

1	NO.	Name	Color
2	1	A	White
3	2	B	Pink
4	3	GND	Yellow
4	4		
5	5		

• USB-RS485 converter for communication

**IBM2A - H1** -

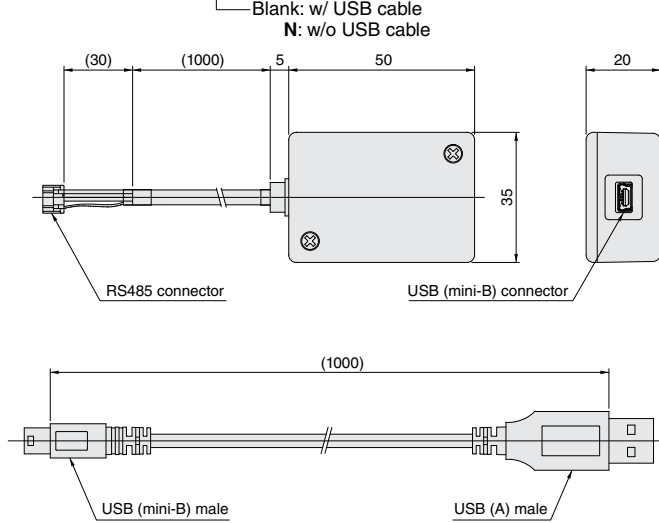

● Terminating resistor

**EW2FR**

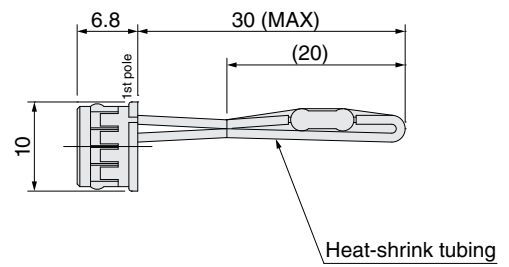

• Connecting cable (loose wires) for main unit\* (robot cable)

**EW2KBA** -

015L: 150mm  
025L: 250mm

Main unit side connector

NO.	Name	Color
1	U	Green
2	V	Brown
3	W	Yellow
4	Vcc	Orange
5	HU	White
6	HV	Red
7	HW	Black
8	GND	Blue

Cable shield

Cable layout chart

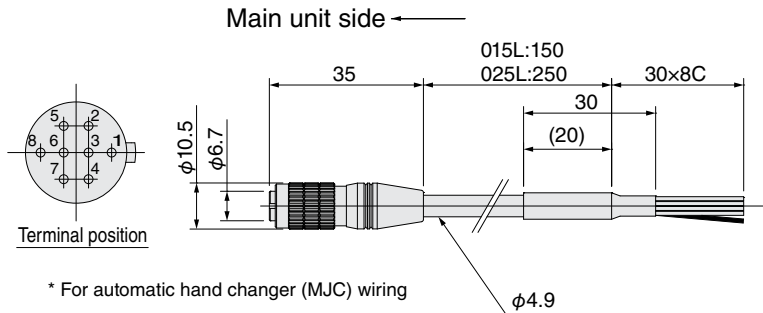

\* For automatic hand changer (MJC) wiring

• Connecting cable (loose wires) for controller\* (robot cable)

**EW2KBB** -

3L: 3m  
5L: 5m

Controller side connector

No.	Name	Color
A1	U	Green
B1	V	Brown
A2	W	Yellow
B2	FG	Shield
A3	Vcc	Orange
B3	GND	Blue
A4	HU	White
B4	HV	Red
A5	HW	Black
B5	N.C.	—

Cable shield

Cable layout chart

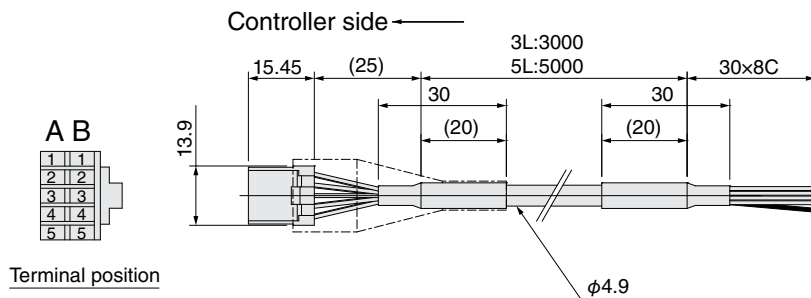

Terminal position

\* For automatic hand changer (MJC) wiring

• Positioning pin

**EW2P -** □

Size

**3** :  $\phi 3$  (for EW2G10□)

**4** :  $\phi 4$  (for EW2G12□ and EW2G16□)

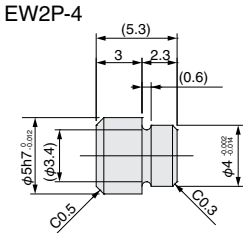
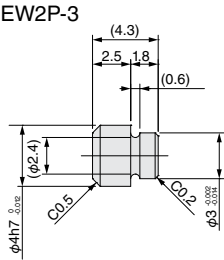

# Chapter 8 Technical Data

## 8-1 Accuracy

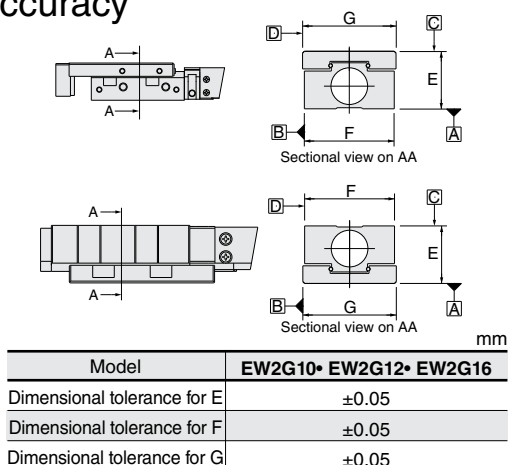

Mounting parallelism(face C relative to face A, face D relative to face B)

Model	Stroke mm							
	10	20	30	40	50	60	80	100
EW2G10□	0.03	-	0.03	-	0.03	-	-	-
EW2G12□	-	0.03	-	0.03	-	0.03	0.05	-
EW2G16□	-	0.03	-	0.03	-	0.03	-	0.06

Traveling parallelism(face C relative to face A, face D relative to face B)

Model	Stroke mm							
	10	20	30	40	50	60	80	100
EW2G10□	0.005	-	0.005	-	0.006	-	-	-
EW2G12□	-	0.005	-	0.005	-	0.007	0.012	-
EW2G16□	-	0.005	-	0.005	-	0.007	-	0.018

## 8-2 Allowable moment

The Low Profile Electric Slider can be used by applying a load directly to it, but be careful that the load or moment does not exceed the value given in the table below. Also, be aware that if the workpiece is brought into a contact with a point offset from the guide in the middle of stroke, a large moment is generated by the thrust of the Low Profile Electric Slider.

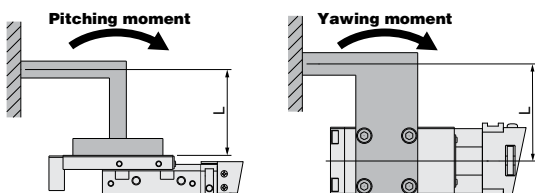

● Allowable moment N·m

Model	Mp	My	Mr
EW2G10□	0.28	0.34	0.38
EW2G12□	1.5	1.7	2.6
EW2G16□	2.1	2.5	4.3

Remarks: For the allowable moment, apply a safety factor of 10 to the calculated value for the guide. However, this calculated value is not a guaranteed value.

● Calculated values for the guide (reference values)

Model	Basic dynamic load rating C (N)	Basic static load rating Co (N)	Static rated moment (N·m)		
			Mp	My	Mr
EW2G10□	417	734	2.8	3.4	3.8
EW2G12□	1710	2690	14.5	17.2	25.6
EW2G16□	2390	3440	20.7	24.7	43.3

Remarks: Common to all strokes. They are not guaranteed values.

● Guide center mm

Model	Stroke	X	Y
EW2G10□	10	31.7	27.3
	30	51.7	47.3
	50	76.7	72.3
EW2G12□	20	48	42
	40	68	62
	60	88	82
	80	108	102
EW2G16□	20	50	43
	40	70	63
	60	90	83
	100	140	133

● Moment direction, guide center X

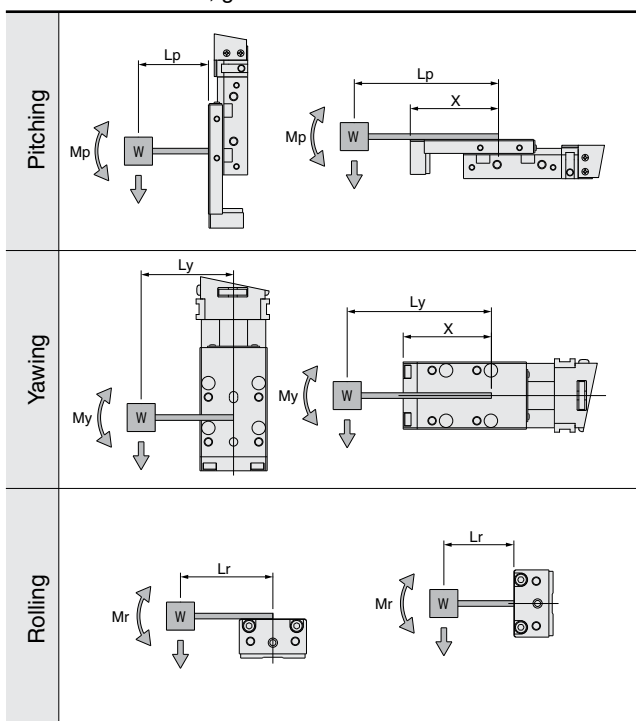

(Guide center Y for EW2G□R)

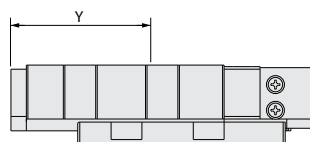

Note: The moment center must be determined based on the guide center shown in the figure.

### 8-3 Displacement angle of the table in relation to bending moment

(Reference value)

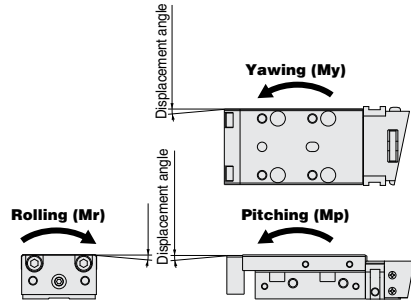

● EW2G10 (Motor size 10)

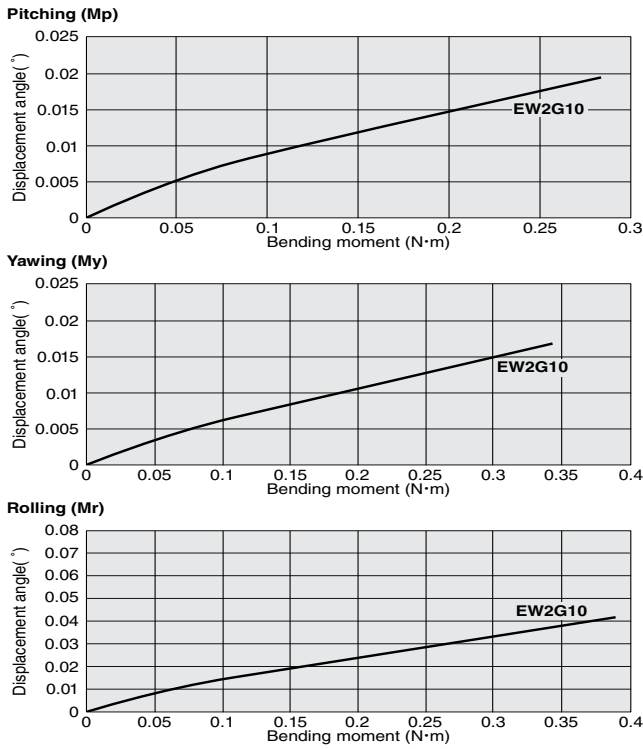

● EW2G12, EW2G16 (Motor size 12, 16)

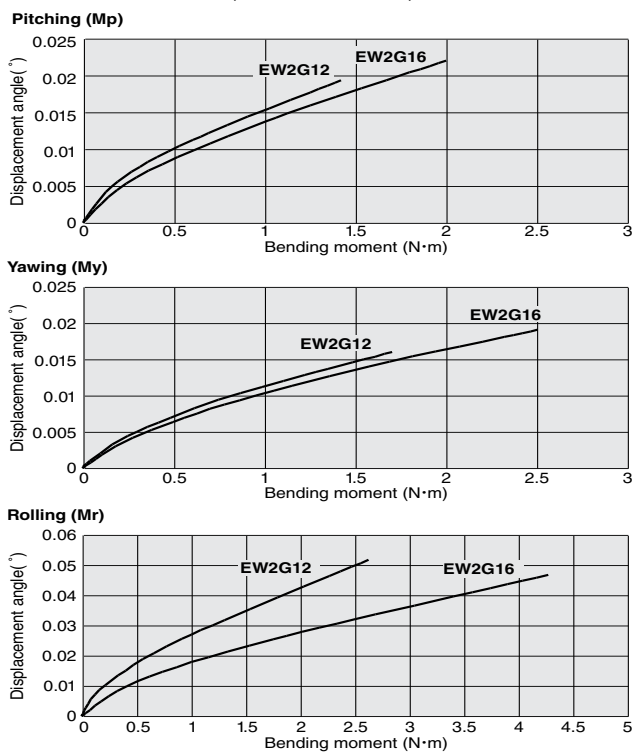

## 8-4 Thrust

Note: The following thrust ranges are just for reference.

Note: They indicate the thrust with the product installed horizontally.

Note: When the product is installed vertically, the thrust may not increase depending on the pushing level and load conditions.

**EW2G10H**

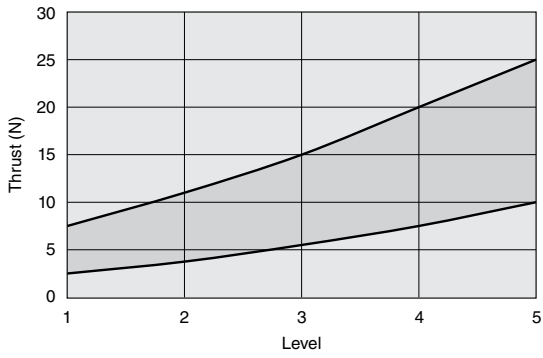

**EW2G10S**

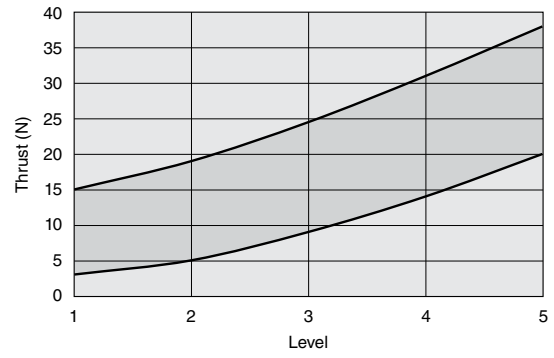

**EW2G12H**

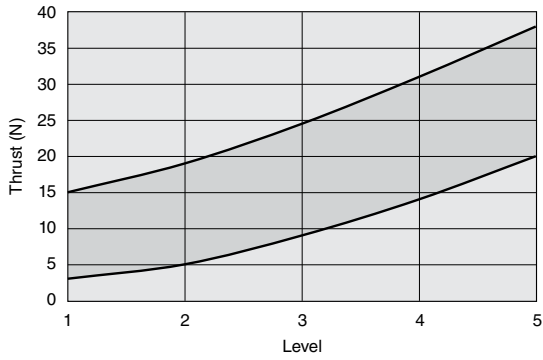

**EW2G12S**

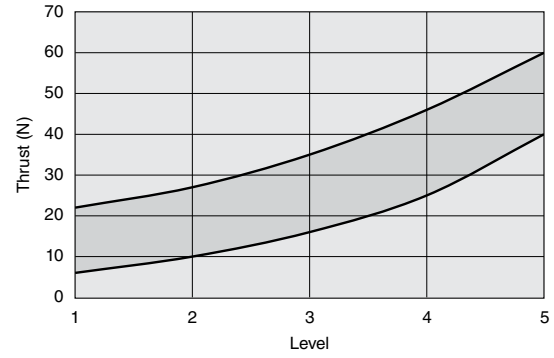

**EW2G16H**

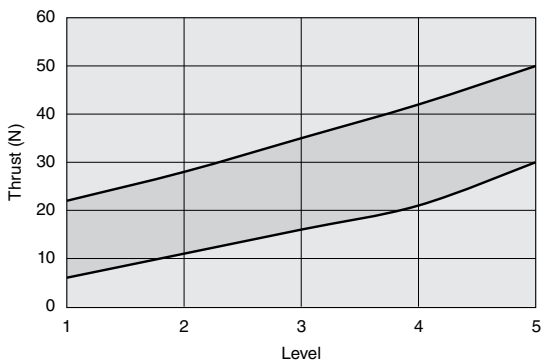

**EW2G16S**

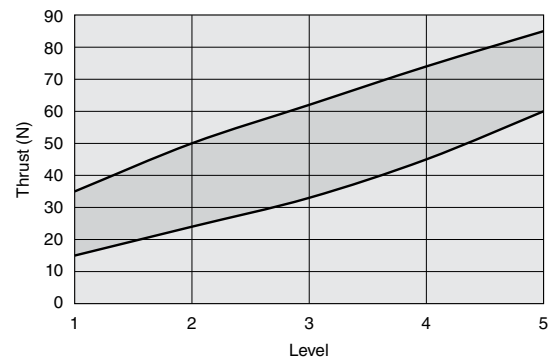

---

If you have questions about the contents of this manual, or about other technical issues, please consult the OVERSEAS DEPARTMENT at the address and telephone number shown below.

<Contact>

Koganei Corporation, Overseas Department  
Address: 3-11-28, Midori-cho, Koganei City, Tokyo  
Tel: 042-383-7172  
Fax: 042-383-7206

**ELEWAVE SERIES**  
**Low Profile Electric Slider**

With point input type controller

With CC-Link type controller

**OWNER'S MANUAL**

March 2022 Ver.1.0 X435295

©Koganei Corporation

The contents of this manual, or any portion thereof, may not be duplicated or copied without permission by Koganei.





**KOGANEI CORPORATION**

Overseas Department

**TEL: 042-383-7172**