



## Compact 2- and 3-Port Media Isolation Valves PVR Series

Compact valves with a large flow rate for medical analysis

**Suitable for cleaning processes in medical analysis, FKM option added to PVR20!**

- Reduced piping work
- \* Direct piping type (Barb fittings)
  - PVR16: 11 mm [0.433 in.]
  - PVR20: 13 mm [0.512 in.]
- Compact valves with large flow rate for medical analysis
- Minimal internal volume by optimized internal flow rate.
  - PVR16: 35 $\mu$ L    PVR20: 60 $\mu$ L



### ① Reduce piping man-hour!

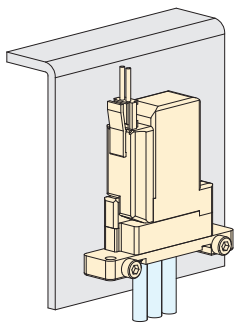

\* Direct piping (barb fitting) only

**Directly connect the tube to barb fittings!**



**CHECK**

Side mounting is possible!

### ② Minimize equipment size!

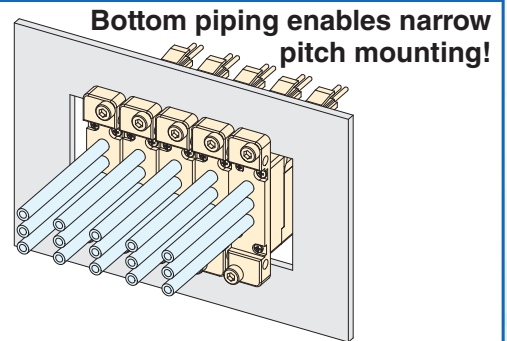

**Bottom piping enables narrow pitch mounting!**

\* Mounting pitch: PVR16 (11 mm [0.433 in.] or more), PVR20 (13 mm [0.512 in.] or more).

### Variation

Base mounting



Sub plate attached



# Compact 2- and 3-Port Media Isolation Valves PVR Series

- Added FKM specifications that are suitable for cleaning processes for medical analysis. (PVR20 only)
- Compact valves with a large flow rate for medical analysis
- Line up includes PVR16 with  $\phi 1.6$  [0.063] orifice and PVR20 with  $\phi 2$  [0.079] orifice.
- Minimized changes to internal volume by using rocker type.
- Wetted area is metal free to improve corrosion resistance.
- Power-saving circuit is standard to achieve low power consumption.
- Long service life reaches 10 million cycles. (\*According to Koganei testing conditions)
- Lineup includes solenoid valve types and air operated types. (PVR16 only)
- 0.3 MPa [44 psi] operating pressure supported. (PVR20 only)

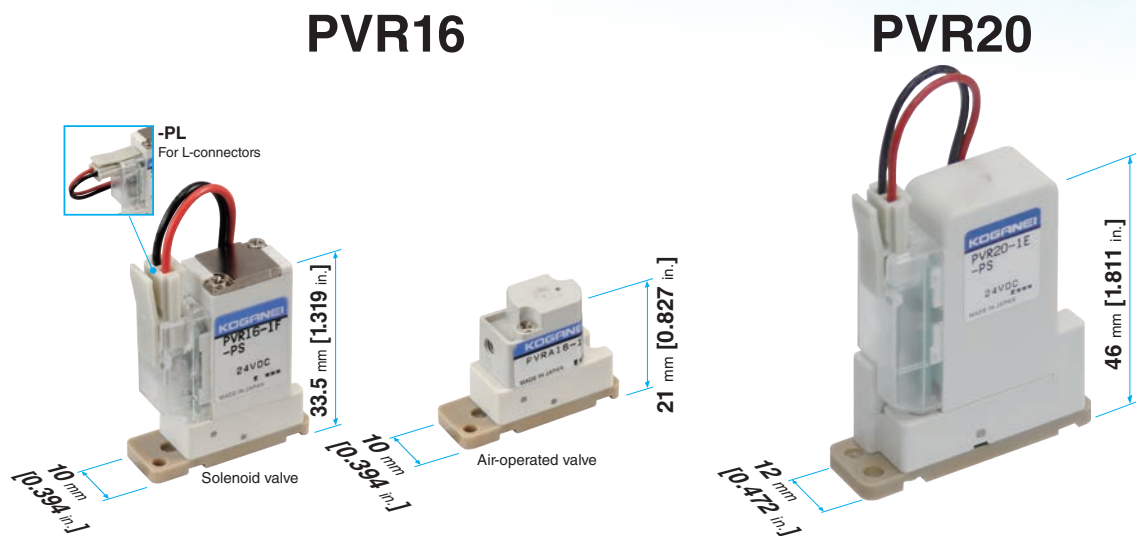

		PVR16	PVR20
Orifice diameter		$\phi 1.6$ [0.063]	$\phi 2$ [0.079]
Flow rate characteristics	Base mounting type	Water: Cv value of 0.04, Air: C value of 0.16 [dm <sup>3</sup> /(S·bar)]	Water: Cv value of 0.065, Air: C value of 0.23 [dm <sup>3</sup> /(S·bar)]
	Direct piping type		
Internal volume		35 $\mu$ L	60 $\mu$ L
Operating pressure range		-0.075 to 0.2 MPa [-11 to 29 psi]	-0.075 to 0.3 MPa [-11 to 44 psi]
Materials Options for the Wetted Parts		Diaphragm: EPDM, FKM, Kalrez <sup>®</sup> Note Body and sub plate: PEEK	<b>NEW</b> Diaphragm: EPDM, <b>FKM</b> Body and sub plate: PEEK
Power consumption		In-rush: 3.7 W, Holding: 1 W	24 VDC: In-rush: 4.5 W, Holding: 1 W 12 VDC: In-rush: 5.2 W, Holding: 1 W

Note: Kalrez<sup>®</sup> is the registered trademark of the U.S. DuPont Corporation.

## Variations in piping

\* Manifolds can also be manufactured to specialized specifications. Contact us for details.

	Base mounting		Direct piping
	Sub plate attached		
PVR16		Side piping Bottom piping	
PVR20		Side piping	

## Internal configuration (rocker-type)

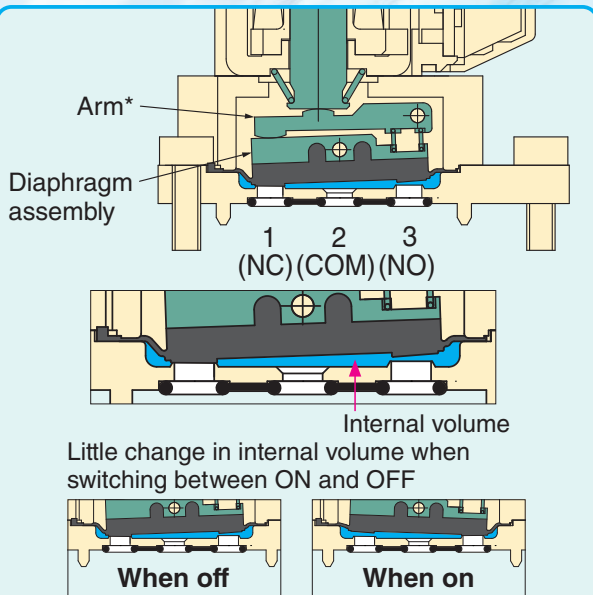

You can reduce the effect on equipment uniformity due to minimal change in the internal volume (pumping volume) caused by the opening and closing movements.

\*Not available with the PVR20.

## Bottom of base mounting type

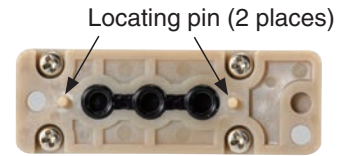

Three-port valve



Two-port valve

Locating pins on bottom allow smooth installation to manifold.

## Example of use

### Dispensing process of analyzer (two-port valve)

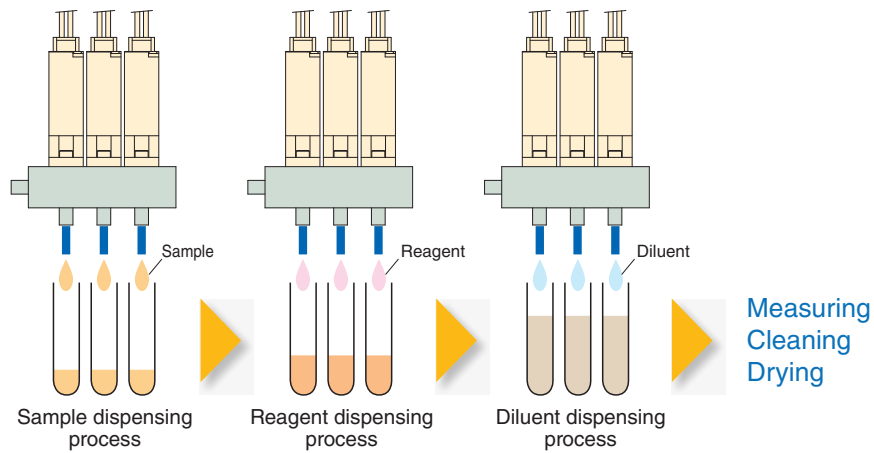

### Cleaning and other processes (two-port valve)

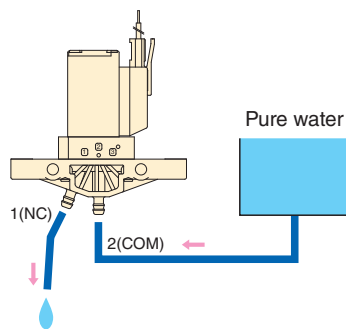

### Separated between two types of vessels (three-port valve)

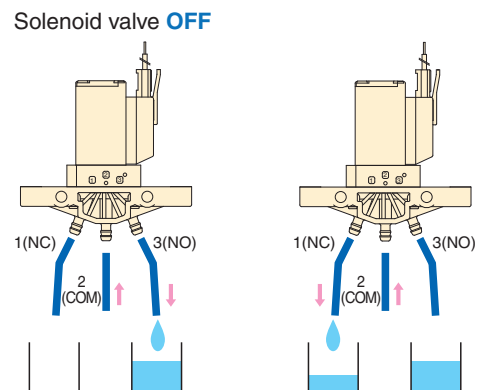

**CAUTION**

Read the safety precautions on [page 3](#) before using this product.





\* Before installation, a consultation about details on use conditions and environmental conditions is required. Be sure to contact Koganei. For inquiries, consult your nearest Koganei sales office or Koganei overseas department. The addresses and telephone numbers are shown on the back cover of this catalog.



Before selecting and using the products, please read all the safety precautions carefully to ensure proper product use. The safety precautions described below are to help you use the product safely and correctly, and to prevent injury to you or other people, and damage to assets.

Always adhere to the following safety regulations: ISO4414 (Pneumatic fluid power - General rules and safety requirements for systems and their components) and JIS B 8370 (Pneumatic system regulations).

The directions are ranked according to degree of potential danger or damage: "DANGER", "WARNING", "CAUTION", and "ATTENTION".

 <b>DANGER</b>	Indicates situations that can be clearly predicted as dangerous. Death or serious injury may result if the situation is not avoided. It could also result in damage or destruction of assets.
 <b>WARNING</b>	Indicates situations that, while not immediately dangerous, could become dangerous. Death or serious injury may result if the situation is not avoided. It could also result in damage or destruction of assets.
 <b>CAUTION</b>	Indicates situations that, while not immediately dangerous, could become dangerous. Minor or semi-serious injury may result if the situation is not avoided. It could also result in damage or destruction of assets.
 <b>ATTENTION</b>	While there is no chance of injury, these points should be observed for appropriate use of the product.

**■ This product was designed and manufactured as a product for specific analytical devices.**

- When selecting and handling compact valves for chemical solutions, the system designer or another person with sufficient knowledge and experience should always read the safety precautions, catalog, instruction manual and other literature before commencing operation. Improper handling is dangerous.
- After reading the instruction manual, catalog, and other documentation, always store them in a location that allows easy availability for reference to users of this product.
- Whenever transferring or lending the product to another person, always attach the catalog, instruction manual, and other information, to the product where they are easily visible in order to ensure that the new user can use the product safely and properly.
- The danger, warning, and caution items listed under these safety precautions do not cover all possible contingencies. Read the catalog and instruction manual carefully, and always keep safety first.

 **DANGER**

- Do not use the product for the purposes listed below:
  1. Medical equipment or medical instruments related to maintenance or control of human lives or bodies
  2. Uses that are expected to have a large effect on human lives, or that are tied to the direct contact with human bodies through machines
  3. Machinery or equipment designed for the purpose of moving or transporting people
  4. Critical safety components in mechanical devices
  5. Feeders that have direct contact with food and drinks

This product has not been planned, designed, or manufactured for purposes that require high levels of safety. Using the product in any of the ways described above creates the risk of injury, loss of customer assets, or loss of human life.
- Do not use the product in locations with or near dangerous substances, such as those that are flammable or ignitable. Do not dispense flammable gases or ignitable chemical solutions through the product. This product is not explosion-proof. Doing so creates the risk of ignition and fire.
- Persons using a pacemaker or other similar medical devices should maintain a distance of at least one meter [3.280 ft] away from the solenoid valve. Getting too close to the product creates the risk of malfunction of a pacemaker due to the solenoid valve's strong magnet.
- When chemical solutions (chemicals) are used, be sure to confirm their compatibility with the constituent materials of this product before use. Using incompatible media could quickly lead to a loss of function, sudden degradation of performance, and a reduced operating life. Using the product in any of the ways described above creates the risk of media leaking externally and, depending on the media, loss of human life.
- When mounting the product and tubes, always make sure they are firmly supported and secured in place. Falling, dropping, or abnormal operation of the product creates the risk of personal injury.
- While the product is in operation, avoid touching it with your hands or otherwise approaching too close. Also, do not attempt to make any adjustments to internal or attached mechanisms, or to perform any type of adjustment (detaching connectors for wires, disconnecting tubes or sealed plugs, adjustment of the product's mounting position, etc.) while the product is in operation. This may cause chemical solutions to flow out, resulting in injury.
- Do not splash water on the product. Spraying water on the product, washing the product, or using the product under water creates the risk of malfunction, leading to injury, electric shock, fire, etc.
- Never attempt to modify the product in any way. Doing so creates the risk of injury, electric shock, fire, etc. due to abnormal operations.
- Never attempt inappropriate disassembly, assembly or repair of the product relating to basic construction, or to its performance or to functions. Doing so creates the risk of injury, electric shock, fire, etc.

 **WARNING**

- Do not use the product in excess of its specification range. Doing so creates the risk of product breakdown, loss of function, or damage. It could also drastically reduce operating life.
- Because Koganei products may be used under a wide variety of conditions, decisions concerning conformance with a particular system should be made upon the careful evaluation by the person in charge of system design. Assurances concerning expected system performance and safety are the responsibility of the designer who decides system conformity. Be sure to use the latest catalogs and technical materials to study and evaluate specification details, to consider the possibility of machine breakdown, and to configure a system that ensures fail-safe safety and reliability.
- Do not use the product with nitric acid, fluorine, or hydrochloric acid.
- The media that can be used are air, water, or fluids that do not affect component parts. Do not use any medium other than these as doing so creates the risk of performance degradation, reduction of operating life, or loss of functions. When corrosive or toxic media are being used, use this product under the responsibility of a person in charge of system design.
- Before supplying pilot air or chemical solutions to this product, and before starting operation, confirm whether the piping is working correctly. If pilot air or chemical solutions are unintentionally supplied, the chemical solutions may leak, flow out into unexpected places, and so on, and create the risk of injury.
- Before conducting maintenance, inspection, repair, replacement, or any other similar procedure for this product (especially when the fluid used is a chemical solution), always confirm that the inner parts of the machine are free of chemical solutions, and that the pilot air is cut off and there is no pressure inside of the pipes. Failure to do so may cause chemical solutions to flow out, resulting in injury.
- After fittings or tubes have been attached, always do a leak test before turning on the flow of any chemical solutions. Confirm there are no leaks and then turn on the flow. Failure to do so may cause chemical solutions to leak, resulting in injury.
- Do not pull on tubes that are attached to fittings. Doing so may cause the tube to become detached, allowing chemical solutions and air to leak.
- When using fittings and tubes, be sure to use compatible thread sizes and compatible tube sizes. Using sizes that are not compatible may cause leaking or the tubes to detach.
- Always check the catalog and other reference materials for correct solenoid valve wiring and piping. Incorrect wiring and piping may result in abnormal operation.
- Do not use a solenoid valve or the wiring that controls it in locations subject to surges or near strong magnetic fields or power lines through which large electric currents flow. It could result in unintended operation.
- Do not attach the solenoid valve to the control panel. Doing so may cause leakage from piping parts due to the heat inside the control panel.
- Implement countermeasures for static electricity, as static electricity may occur, depending on the media.

- Use countermeasures for heat dissipation so that the ambient temperature falls within the temperature range for normal specifications if the solenoid valve is installed inside the control panel.
- Use countermeasures for heat dissipation so that the ambient temperature falls within the temperature range for normal specifications when the energizing time for the solenoid valve is long. Also, contact Koganei when continuously energizing for long periods of time.
- When a solenoid valve is turned off, it may generate a surge voltage or an electromagnetic wave that affects the operation of surrounding equipment. Use countermeasures for electromagnetic waves and surges to electric circuits.
- Before performing any kind of wiring work for the solenoid valve, be sure to turn off the power. Failure to do so creates the risk of electric shock.
- After completing wiring work for the solenoid valve, check to make sure that all connections are correct before turning on the power.
- Correctly apply the rated voltage to the solenoid of the solenoid valve. Applying the wrong voltage will make it impossible to obtain the rated function, and creates the risk of damage to and burnout of the product.
- Do not allow the lead wires of the solenoid valve to become damaged. Allowing lead wires to become damaged, bent excessively, pulled, rolled up, placed under heavy objects, or squeezed between two objects creates the risk of current leaks or defective continuity that can lead to fire, electric shock, or abnormal operation.
- Do not connect or disconnect connectors while the power is turned on. Also, never apply unnecessary force to connectors. Doing so creates the risk of personal injury, device damage, and electric shock due to abnormal machine operation.
- Do not touch terminals or switches while power to the solenoid valve is turned on. Doing so creates the risk of electric shock and abnormal operation.
- Design devices that ensure safety to prevent damage to machinery and personal injury when the machine is shut down due to an emergency stop or system abnormalities, such as an electrical power failure.
- Be sure to perform a startup inspection and test operations when operating for the first time after storage or after 48 hours or more of suspended operation.
- When the product has been unattended for a long time, it is possible that the moving parts may have become stuck, causing operating lags or sudden movements.
- When the device has not been used for long periods (over 30 days), it is possible that the contacting parts may have become stuck leading to slow operation or sudden movements. Check for proper operation a minimum of once every 30 days.
- Do not sit on the product, place your foot on it, or place other objects on it. Doing so creates the risk of injury due to tripping or the product tipping over or falling, resulting in product damage and abnormal, erratic, or runaway operation.
- Do not allow the product to be thrown into fire. Doing so creates the risk of the product exploding or the release of toxic gases.

## CAUTION

- It could lead to early shutdown of some functions, a sudden degradation of performance, and a reduced operating life. It could lead to early shutdown of some functions, a sudden degradation of performance, and a reduced operating life. For information about materials, see the order code column.
- This product is not waterproof. It cannot be used in places that are exposed to water or chemical solutions.
- When installing the product, be sure to allow adequate work space around it. Failure to do so will make it more difficult to conduct daily inspections or maintenance, which could eventually lead to system shutdown or damage to the product.
- Always be sure to post a "Work in Progress" sign during installation, adjustment, or other operations, to avoid supplying unintended chemical solutions, pilot air, or electric power. Unintended supply of chemical solutions, pilot air, or electric power can cause the product to operate suddenly, creating the risk of personal injury.
- Do not use the solenoid valve in locations subject to large electric currents or strong magnetic fields. It could result in erratic operation.
- Do not bring any magnetic media or memory within one meter [3.280 ft] of energized solenoid valves. Doing so creates the risk of damage to data on the magnetic media due to magnetism.
- Depending on the product, unintended operations may occur when a leakage current occurs in the control circuit of the solenoid valve. Use countermeasures against current leakages in the control circuit so as not to exceed the allowable current values for the product's specifications.
- Do not obstruct the product's breather. Pressure fluctuations occur depending on the change in volume while in operation. The pressure balance is disrupted when the breather is obstructed and control operations are unable to be done, causing injury and damage to the device.
- Oil discharged from the compressor can cause a drastic reduction in the functionality of the solenoid valves or a reduction in operating life. Be sure to install air purifying devices to the primary side to the mist filter for oil removal.
- Using extremely dry air with a dew point lower than -20°C [-4°F], may affect the quality of the lubricating oil used. This creates the risk of degraded performance, loss of function, or other problems.

## ATTENTION

- Whenever considering use of this product in situations or environments not specifically noted in the catalog or in manuals, or in applications where safety is an important requirement such as in aircraft facilities, combustion facilities, leisure equipment, safety equipment, and other places where human life or assets may be greatly affected, take adequate safety precautions such as allowing plenty of margin for ratings and performance, or fail-safe measures. Be sure to contact Koganei.
- Test the materials of the wetted parts in advance for chemical resistance to the media.
- Always check the catalog and other reference materials for product wiring and piping.
- Use a protective cover and other means to ensure that the operating parts of mechanical devices are isolated and do not come into direct contact with human bodies.
- When handling the product, wear protective gloves, safety glasses, safety shoes, and other protective clothing whenever necessary.
- When the product can no longer be used or is no longer necessary, dispose of it appropriately as industrial waste.
- Compact valves for chemical solutions can exhibit degraded performance and function over their operating lives. Always conduct daily inspections and confirm that all requisite system functions are satisfied to prevent accidents from happening.
- Before installation, a consultation about details on use conditions and environmental conditions is required. Be sure to contact Koganei. For inquiries, consult your nearest Koganei sales office or Koganei overseas department. The addresses and telephone numbers are shown on the back cover of this catalog.

## Other

- Always observe the following items.
  1. When using this product in a fluid media system or a pneumatic system as a pilot, always use genuine Koganei or compatible (recommended) parts.  
Use only authentic Koganei parts or compatible parts (recommended parts) to do maintenance or repairs.  
Always observe the prescribed methods and procedures.
  2. Never inappropriately disassemble or modify the product in relation to its basic construction, performance, or functions.

Koganei cannot be held responsible for any problems that occur as a result of these safety precautions not being properly observed.

## Warranty and General Disclaimer

1. **Warranty Period**  
The warranty period for Koganei products is 1 year from the date of delivery.  
\* However, some products have a 2-year warranty; contact your nearest Koganei sales office or the Koganei overseas department for details.
2. **Scope of Warranty and General Disclaimer**
  - (1) When a product purchased from Koganei or from an authorized Koganei distributor or agent malfunctions during the warranty period in a way that is attributable to Koganei's responsibility, Koganei will repair or replace the product free of charge. Even if a product is still within the warranty period, its durability is determined by its operation cycles and other factors. Contact your nearest Koganei sales office or the Koganei overseas department for details.
  - (2) The Koganei product warranty covers individual products. Therefore, Koganei is not responsible for incidental losses (repair of this product, various expenses required for replacement, etc.) caused by breakdown, loss of function, or loss of performance of Koganei products.
  - (3) Koganei is not responsible for any losses or for any damages to other machinery caused by breakdown, loss of function, or loss of performance of Koganei products.
  - (4) Koganei is not responsible for any losses due to use or storage of the product in a way that is outside of the product specifications prescribed in Koganei catalogs and instruction manuals, and/or due to actions that violate the mounting, installation, adjustment, maintenance or other safety precautions.
  - (5) Koganei is not responsible for any losses caused by breakdown of the product due to factors outside the responsibility of Koganei, including but not limited to fire, natural disaster, the actions of third parties, and intentional actions or errors by the purchaser.

## Handling instructions and precautions

### Mounting and piping

- Before installing piping, flush (with compressed air) or wash thoroughly to remove dirt from the inside of the pipes.
- The tightening torque when doing piping and when mounting valves is to be tightened to that of the following tightening torques.

#### PVR16

Item	Thread size	Tightening torque N·m [in·lbf]
Valve mounting	M2×0.4	0.16 to 0.2 [1.416 to 1.770]
Valve mounting	M3×0.5	0.27 to 0.33 [2.390 to 2.921]
Pilot port piping (PVAR16)	M3×0.5	0.1 to 0.11 [0.885 to 0.974]
Sub plate piping	M6×1, 1/4-28UNF	1.5 to 1.8 [13.277 to 15.932]

#### PVR20

Item	Thread size	Tightening torque N·m [in·lbf]
Valve mounting	M3×0.5	0.27 to 0.33 [2.390 to 2.921]
Sub plate piping	M6×1, 1/4-28UNF	1.5 to 1.8 [13.277 to 15.932]

- When using valves side-by-side, use the mounting pitch shown below.  
PVR16: 11 mm [0.433 in.] or more  
PVR20: 13 mm [0.512 in.] or more
- Refrain from touching the screws used for assembling the body, adapter, and coils, as doing so is a main cause of decreased functionality.
- Do not use in locations at which the body is subjected to excessive impacts and/or vibrations.  
Shock resistance: 147m/s<sup>2</sup> (15G), Vibration resistance 29.4m/s<sup>2</sup> (3G).

### Piping of tubes

Be aware of the following items when piping tubes with barb fittings.

- Cut the tubes perpendicular to their axial direction. Allow for leeway in their length.
- Firmly insert the barb fittings all the way to the end of the tubes. Inserting tubes carelessly creates the risk of leaking or detaching.
- When attaching or detaching tubes, be careful that no excessive force is applied, such as from large lateral loads on the barb joints, or stretching and compressing the tubes after they are installed.

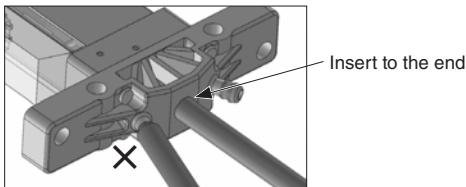

### Quality of the media

- When using fluids (chemical solutions), they may cause crystallization or solidification. This can result in leakage from the sheet or defective valve movements. Conduct measures for appropriate cleaning as necessary.
- When using water, attach a standard 100 mesh filter strainer to the primary side of the piping.
- When using air, it should be clean air that contains no degraded compressor oil, etc. Install an air filter (filtration of 5 μm or less) near the valve to remove dust and collected liquid. Also drain the air filter periodically.

### Precautions when mounting valves

When purchasing base mounted types, they are shipped with two valve-mounting screws that are assembled on the valve body at the time of shipping.

The screws cut partially through the through-holes of the valve body to prevent the screws from falling out and becoming lost, creating a configuration that cannot be immediately removed from the body.

Be careful not to damage the threads by forcefully pushing when mounting the valves, as the through-holes are not complete.

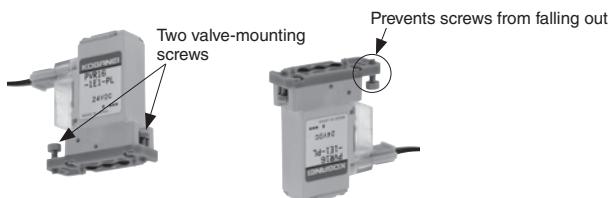

### Attaching and removing plug connector

Use fingers to insert the connector into the pin, push it in until the lever claw latches onto the protruded section of the connector housing, and complete the connection.

To remove the connector, squeeze the lever along with the connector, lift the lever claw up from the protruded section of the connector housing, and pull it out.

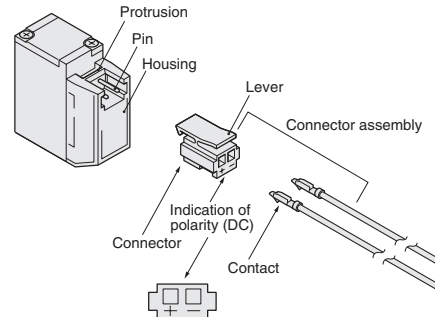

### Crimping of connecting lead wire and contact

To crimp lead wires into contacts, strip off 4 mm [0.157 in.] of the insulation from the end of the lead wire, insert it into the contact, and crimp it. Be sure at this time that the insulation does not cover the part of the exposed wire being crimped.

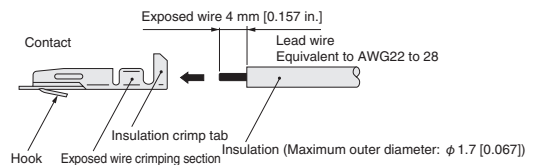

- Do not pull hard on the lead wire.
- Always use a specialized tool to crimp the lead wire and contact.  
Contact : Model 702062-2M  
Manufactured by Sumiko Tec Co., Ltd.  
Crimping tool : Model F1-702062  
Manufactured by Sumiko Tec Co., Ltd.

### Attaching and removing contact and connector

Insert the contact with lead wire into the square hole on the connector so the contact hook latches on and is secured to the connector. Confirm that the lead wire cannot be easily pulled out.

To remove it, insert a tool with a fine tip (such as a small screwdriver) into the rectangular hole on the side of the plug connector to push up on the hook, and then pull out the lead wire.

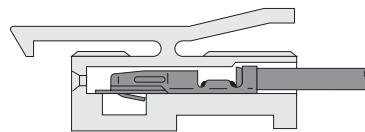

- Do not pull hard on the lead wire. It could result in defective contacts, broken wires, etc.
- If a pin is bent, use a small screwdriver, or something similar, to gently straighten out the pin, and then fit the connector.

# Operation principles and symbols

Solenoid valve  
**PVR16**

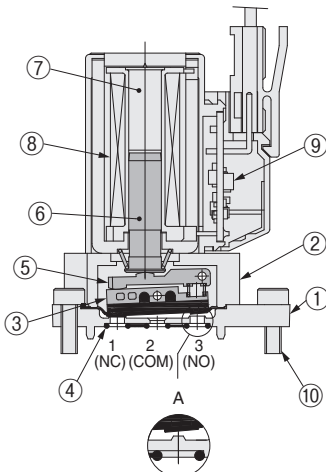

Part A (when 2 ports)

Direct piping (barb fitting)  
**PVR16**

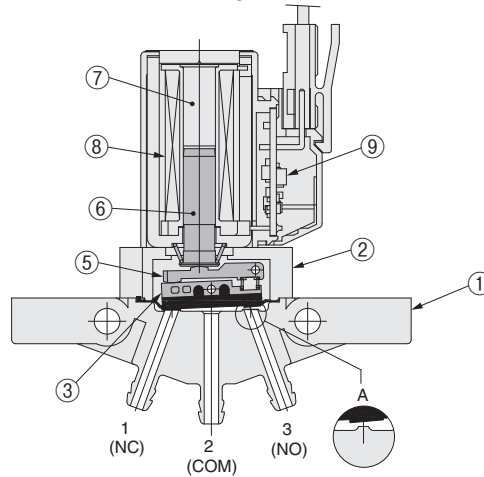

Part A (when 2 ports)

Air-operated valve  
**PVRA16**

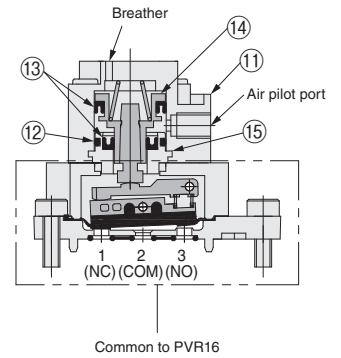

Common to PVR16

## Materials used in major parts

Name	Materials
① Main unit	PEEK
② Adapter 1	PBT
③ Diaphragm assembly	EPDM,FKM,Kalrez®
④ Gasket	EPDM,FKM,Kalrez®

Name	Materials
⑤ Arm	PEEK
⑥ Plunger	Solenoid SUS
⑦ Column	Solenoid SUS
⑧ Coil assembly	-

Name	Materials
⑨ Circuit board assembly	-
⑩ Mounting screw	SUS
⑪ Adapter 2	PBT
⑫ O-ring	NBR

Name	Materials
⑬ Packing	NBR
⑭ Piston assembly	POM+SUS
⑮ Cylinder L	POM

Solenoid valve  
**PVR20**

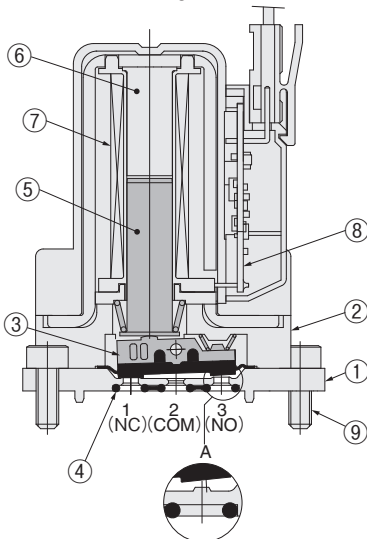

Part A (when 2 ports)

Direct piping (barb fitting)  
**PVR20**

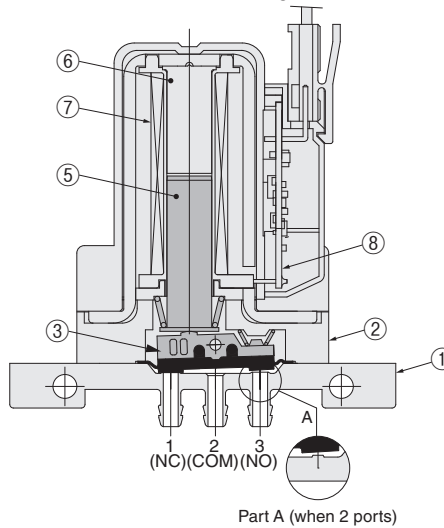

Part A (when 2 ports)

## Materials used in major parts

Name	Materials
① Main unit	PEEK
② Adapter	PBT
③ Diaphragm assembly	NEW EPDM NEW FKM
④ Gasket	NEW EPDM NEW FKM

Name	Materials
⑤ Plunger	Solenoid SUS
⑥ Column	Solenoid SUS
⑦ Coil assembly	-
⑧ Circuit board assembly	-
⑨ Mounting screw	Mild steel (Nickel plated)

## Symbol

**PVR16**  
**PVR20**  
Three-port

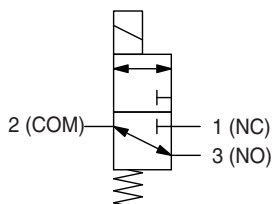

**PVR16-2**  
**PVR20-2**  
Two-port (NC)

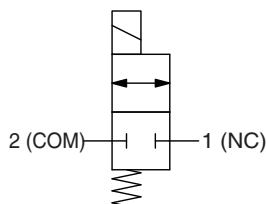

**PVRA16**  
Three-port

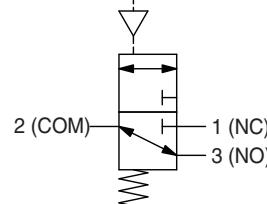

**PVRA16-2**  
Two-port (NC)

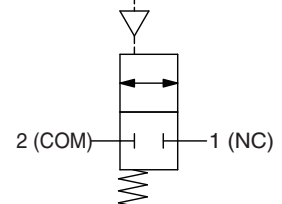

Note: Apply the media via the 2 (COM) port.



# Specifications

Item	Model	PVRA16-2	PVRA16	PVR16-2	PVR16	PVR20-2	PVR20
Type of valve operation		Air-operated valve (internal pilot type)		Solenoid valve (direct acting type)		Solenoid valve (direct acting type)	
Valve configuration		Diaphragm type poppet (rocker-type)		Diaphragm type direct poppet (rocker-type)		Diaphragm type direct poppet (rocker-type)	
Number of ports (Valve function)		2 (Normally closed (NC))	3	2 (Normally closed (NC))	3	2 (Normally closed (NC))	3
Media		Air, water, pure water, chemical solution <sup>Note 1</sup>					
Operating pressure range	Main valve part MPa [psi]	-0.075 to 0.2 [-11 to 29] (COM→NC,NO) <sup>Note 2</sup>				-0.075 to 0.3 [-11 to 44] (COM→NC,NO) <sup>Note 2</sup>	
	Air-operated part MPa [psi]	0.15 to 0.30 [22 to 44]		—		—	
Pressure resistant	Main valve part MPa [psi]	0.3 [44]				0.45 [65]	
	Air-operated part MPa [psi]	0.4 [58]		—		—	
Orifice diameter	mm [in.]	1.6 [0.063]				2 [0.079]	
Flow rate characteristics	Base mounting	Water: Cv value of 0.04 Air: C value of 0.16 [dm <sup>3</sup> /(S·bar)]				Water: Cv value of 0.065 Air: C value of 0.23 [dm <sup>3</sup> /(S·bar)]	
	Direct piping						
Capacity in the valve chamber <sup>Note 3</sup>	μl	35				60	
Amount of leakage	cm <sup>3</sup> /min	Both inside and outside are 0 (with water pressure)					
Response time <sup>Note 4</sup>	ms	—		Under 15 [under 20 if Kalrez] (with air pressure)		Under 15 (with air pressure)	
Maximum operating frequency	Hz	2					
Operating temperature range	°C [°F]	0 to 50 [32 to 122]					
Operating temperature range for media used	°C [°F]	0 to 50 [32 to 122] (non-condensation)					
Mass	No sub plate g [oz]	7 [0.25]		20 [0.71]		42 [1.48]	
	Sub plate attached g [oz]	14 [0.49]		27 [0.95]		50 [1.76]	
	Direct piping	—		22 [0.78]		43 [1.52]	
Mounting direction		Any					

Note 1: We ask that you test the materials of the wetted parts in advance for chemical resistance to the media.

2: Apply the media via the 2 (COM) port.

3: Shows the clearance volume of the internal valve chamber that was deducted from the volume of the diaphragm.

4: Be aware that, for the diaphragm material FKM, Kalrez®, if the media or ambient temperature falls below 15°C [59°F], the switch time for the valve will become excessively long. The response time for PVRA (air pilot valve) differs depending on the pilot valve, piping diameter, and piping length. (PVR16 only)

Remark 1: This solenoid valve has no waterproof specifications. Be aware that there is a risk of shorting or damaging the solenoid valve if water or reagents are poured onto the lead wire assembly.

2: When using, consider the force of the water pressure (water ram) and do settings so as not to exceed the operating pressure.

\* Before installation, a consultation about details on use conditions and environmental conditions is required. Be sure to contact Koganei. For inquiries, consult your nearest Koganei sales office or Koganei overseas department. The addresses and telephone numbers are shown on the back cover of this catalog.

## Solenoid specifications

### PVR16

Item	Rated voltage	DC12V	DC24V
Applicable voltage range <sup>Note 1</sup>	V	11.4 to 13.2 12 (+10%, -5%)	21.6 to 26.4 24±10%
Current	Startup mA	308	154
	Steady mA	83	42
Power consumption <sup>Note 2</sup>	Startup W	3.7	
	Steady W	1	
Allowable circuit leakage current <sup>Note 3</sup>	mA	4	
Indicator lamp		Red LED	
Insulation resistance	MΩ	Minimum 100 <sup>Note 4</sup>	
Surge suppression		Surge absorption transistor	

### PVR20

Item	Rated voltage	DC12V	DC24V
Applicable voltage range <sup>Note 1</sup>	V	11.4 to 13.2 12 (+10%, -5%)	21.6 to 26.4 24±10%
Current	Startup mA	433	188
	Steady mA	84	42
Power consumption <sup>Note 2</sup>	Startup W	5.2	4.5
	Steady W	1	
Allowable circuit leakage current <sup>Note 3</sup>	mA	4	
Indicator lamp		Red LED	
Insulation resistance	MΩ	Minimum 100 <sup>Note 4</sup>	
Surge suppression		Surge absorption transistor	

Note 1: It will not operate if the power supply voltage gradually increases. Be sure to apply the appropriate voltage.

2: The power-saving circuit is standard equipment.

3: Malfunctions, such as the solenoid valve not returning to normal, may occur if there is a leakage current within the circuit. Be sure to use the product below the allowable circuit leakage current.

4: Value from a 500 VDC Megger.

#### Internal circuit

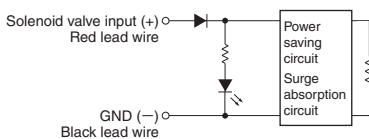

#### Power waveform of the power-saving circuit

##### ● PVR16

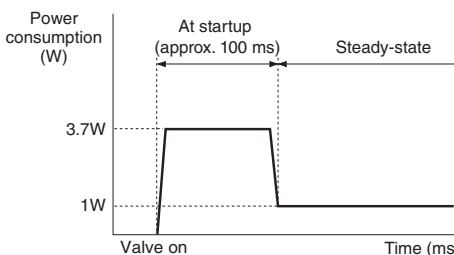

##### ● PVR20

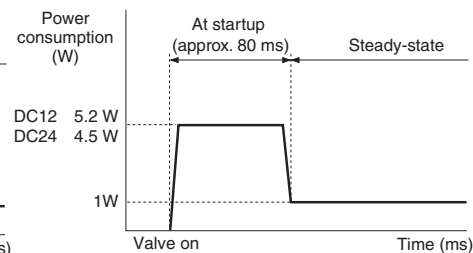

Do not perform megger tests between pins.

#### Wiring

When running the power line, keep the total length from the power source to less than 3 m [9.840 ft].

Also, if the total length from the power source exceeds 300 mm [11.811 in.], be sure to use a twisted pair cable.



## Order codes

### ● Solenoid valve

**PVR16** -  -    -



Code	Voltage
<b>DC12V</b>	DC12V
<b>DC24V</b>	DC24V

Code	Wiring specifications
<b>PL</b>	L-connector (lead wire with connector: 300 mm [11.811 in.] provided)
<b>PS</b>	Straight connector (lead wire with connector: 300 mm [11.811 in.] provided)
<b>PLN</b>	L-connector (no lead wire with connector)
<b>PSN</b>	Straight connector (no lead wire with connector)

Code	Number of ports
Blank	Three-port
<b>2</b>	Two-port (NC)

Code	Material for the body
<b>1</b>	PEEK

Code	Materials for the rubber
<b>E</b>	EPDM
<b>F</b>	FKM
<b>K</b>	Kalrez® (FFKM)

\*This is the material for diaphragm and gasket.

Code	Piping type	Availability of sub plate	Piping direction and size
Blank	Base piping type	No sub plate	-
<b>1</b>		Sub plate attached	Bottom M6×1
<b>2</b>			Bottom 1/4-28 UNF
<b>3</b>			Side M6×1
<b>4</b>		Side 1/4-28 UNF	
<b>BF4</b>	Direct piping type	No sub plate	Bottom φ4 [0.157] barb fitting (For urethane tube φ4 [0.157]×2.5)

**PVR20** -  -    -



Code	Voltage
<b>DC12V</b>	DC12V
<b>DC24V</b>	DC24V

Code	Wiring specifications
<b>PS</b>	Straight connector (lead wire with connector: 300 mm [11.811 in.] provided)
<b>PSN</b>	Straight connector (no lead wire with connector)

Code	Number of ports
Blank	Three-port
<b>2</b>	Two-port (NC)

Code	Material for the body
<b>1</b>	PEEK

Code	Materials for the rubber
<b>E</b>	EPDM
<b>F</b>	FKM

\*This is the material for diaphragm and gasket.

Code	Piping type	Availability of sub plate	Piping direction and size
Blank	Base piping type	No sub plate	-
<b>3</b>		Sub plate attached	Side M6×1
<b>4</b>			Side 1/4-28 UNF
<b>BF4</b>	Direct piping type	No sub plate	Bottom φ4 [0.157] barb fitting (For urethane tube φ4 [0.157]×2.5)

### ● Air-operated valve

**PVRA16** -  -



Code	Material for the body
<b>1</b>	PEEK

Code	Materials for the rubber
<b>E</b>	EPDM
<b>F</b>	FKM
<b>K</b>	Kalrez® (FFKM)

\*This is the material for diaphragm and gasket.

Code	Number of ports
Blank	Three-port
<b>2</b>	Two-port (NC)

Code	Availability of sub plate	Piping direction and size
Blank	No sub plate	-
<b>1</b>	Sub plate attached	Bottom M6×1
<b>2</b>		Bottom 1/4-28 UNF
<b>3</b>		Side M6×1
<b>4</b>		Side 1/4-28 UNF

## Additional parts

### ● Sub plate (unit: 1 piece)

**PVR16 - SP**



Side piping

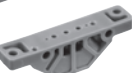

Bottom piping

Code	Piping direction and size
<b>1</b>	Bottom M6×1
<b>2</b>	Bottom 1/4-28 UNF
<b>3</b>	Side M6×1
<b>4</b>	Side 1/4-28 UNF

**PVR20 - SP**



Side piping

Code	Piping direction and size
<b>3</b>	Side M6×1
<b>4</b>	Side 1/4-28 UNF

### ● Connector related

**EAZ** -

Code	Connector specifications
<b>P</b>	Lead wire with connector Length 300 mm [11.811 in.]
<b>PN</b>	Connector alone (With contact)

### ● Gasket (unit: 1 piece)

**PVR16 - GK**



Code	Materials for the rubber
<b>E</b>	EPDM
<b>F</b>	FKM
<b>K</b>	Kalrez® (FFKM)

**PVR20 - GK**



Code	Materials for the rubber
<b>E</b>	EPDM
<b>F</b>	FKM

Solenoid valve

● PVR16-2 2-port, normally closed (NC)

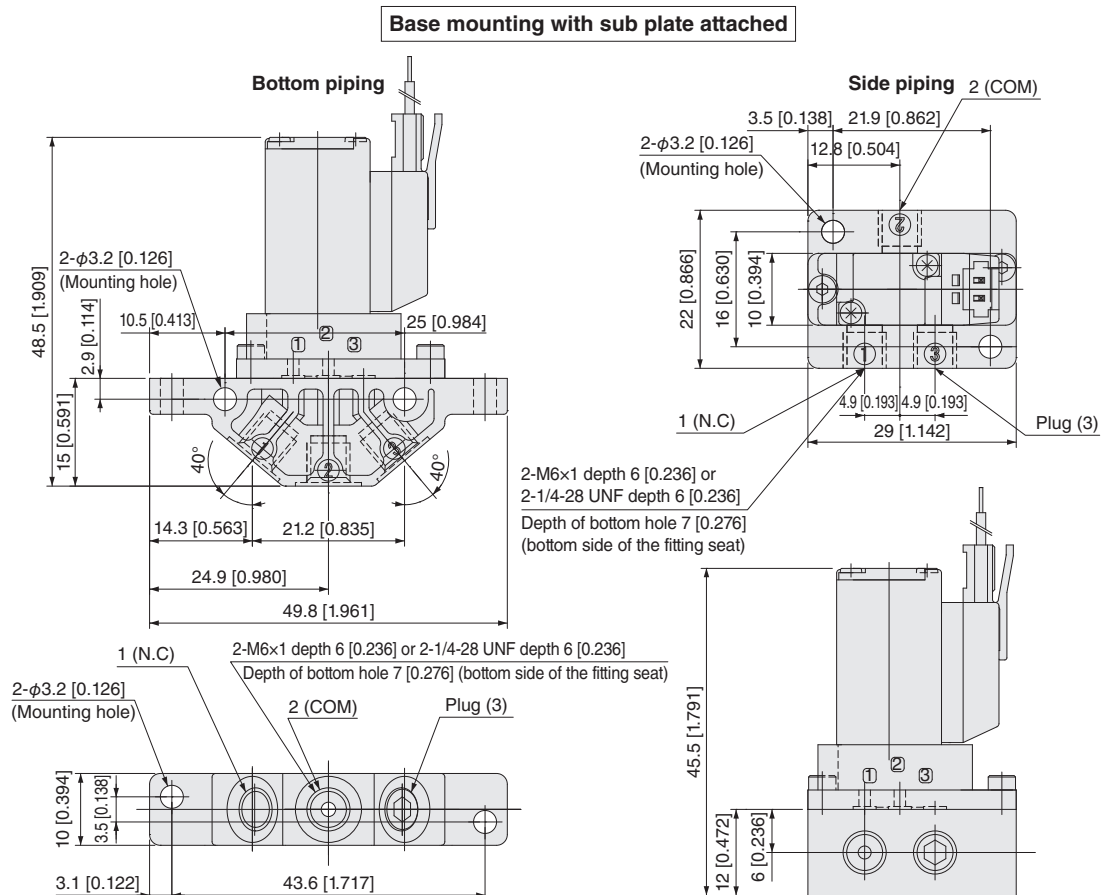
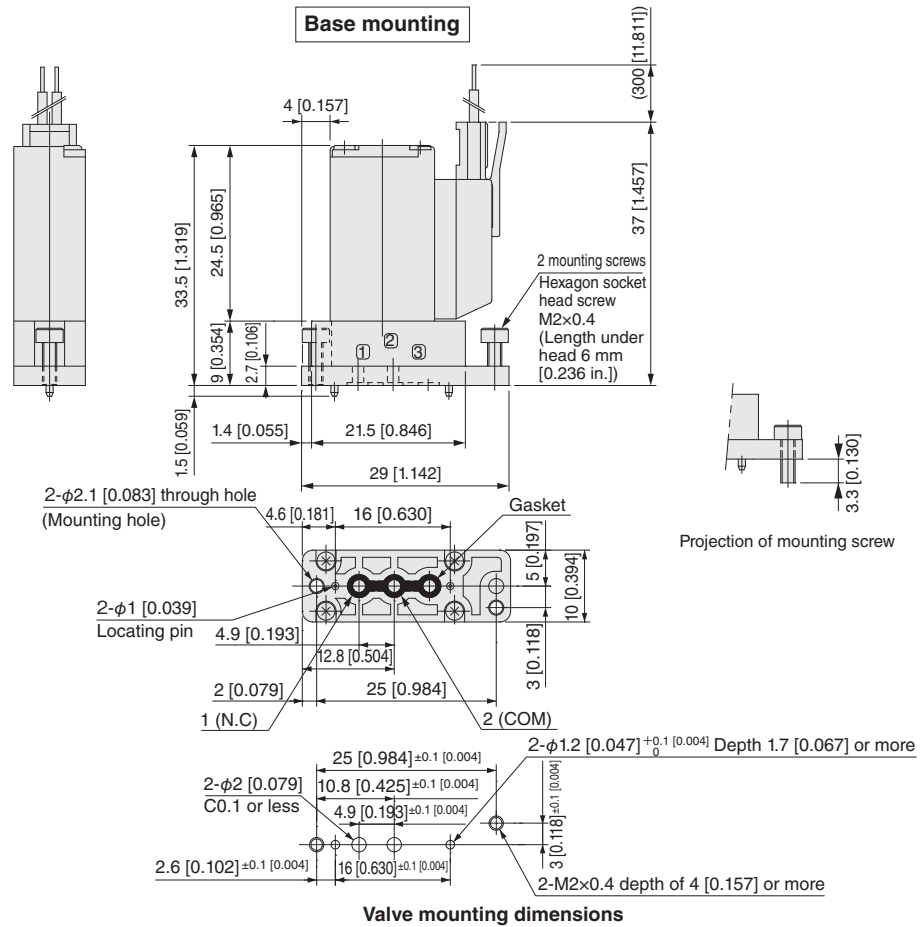

Solenoid valve

● **PVR16-2** 2-port, normally closed (NC)

**Direct piping**

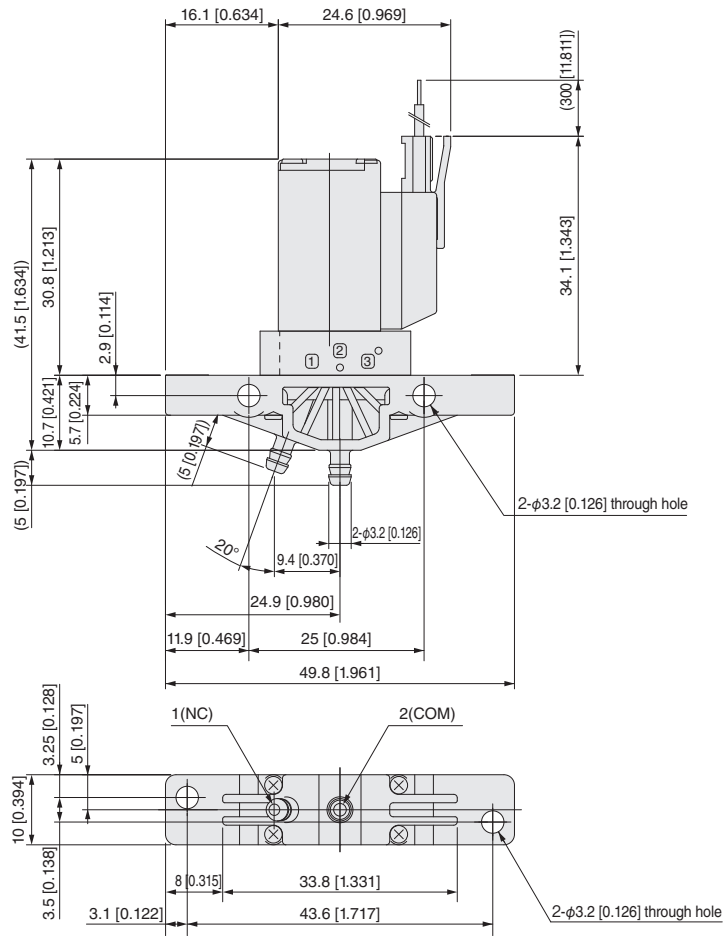

**Wiring specifications**

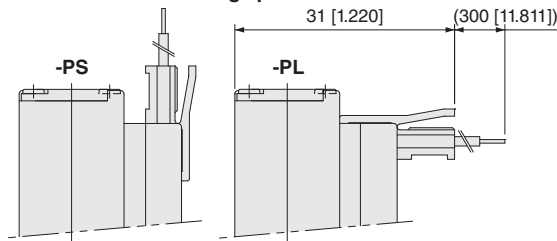

Solenoid valve

● PVR16 3-port

Base mounting

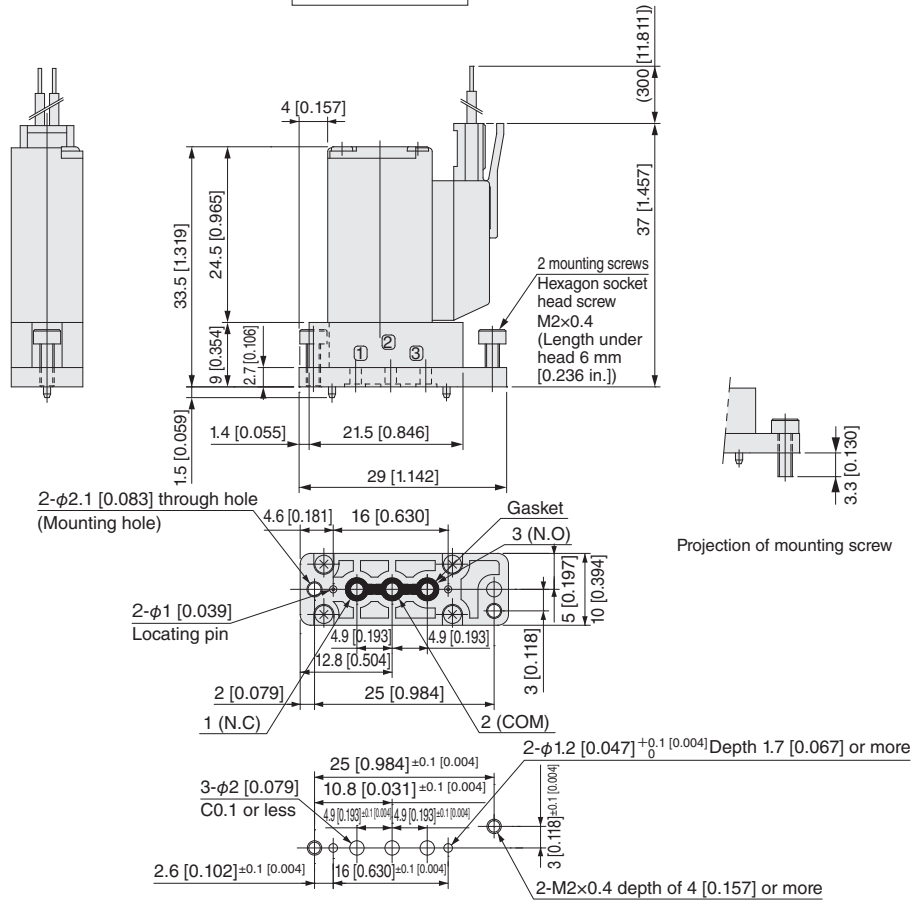

Valve mounting dimensions

Base mounting with sub plate attached

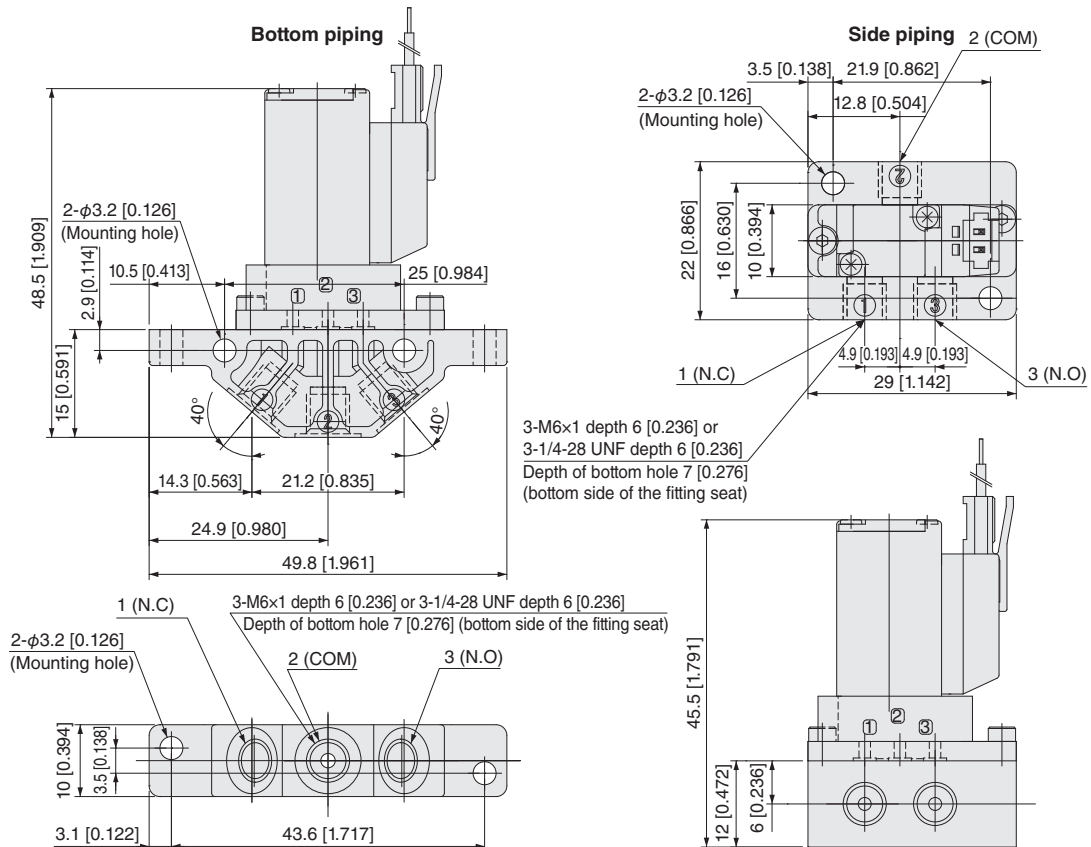



Solenoid valve

● PVR16 3-port

Direct piping

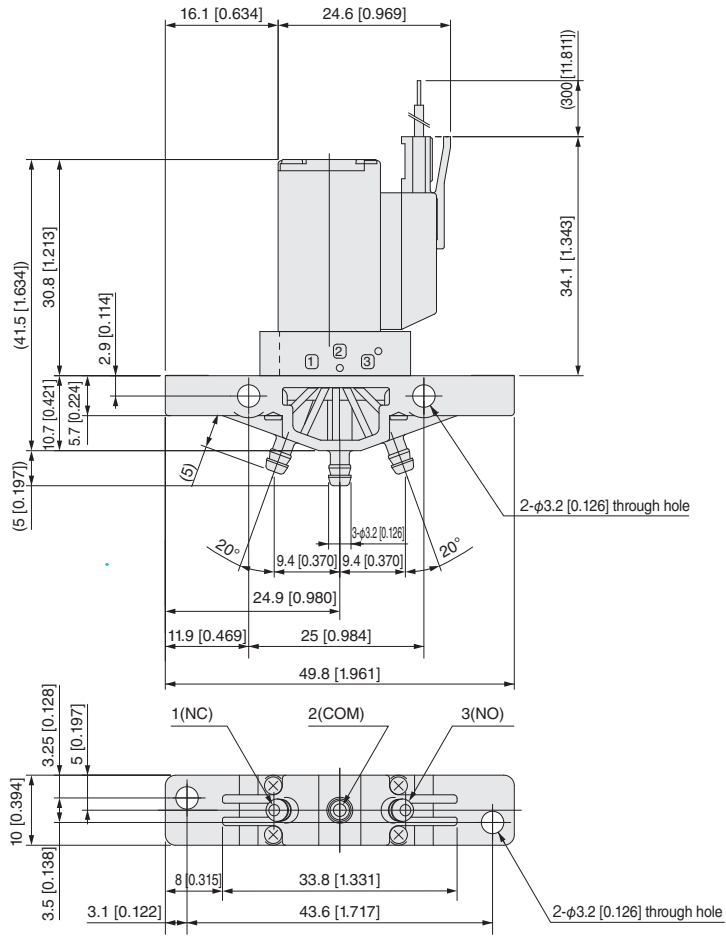

Wiring specifications

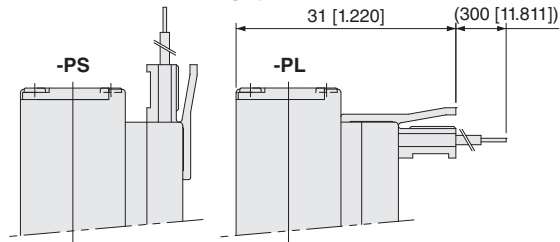

Air-operated valve

● PVRA16-2 2-port, normally closed (NC)

Base mounting

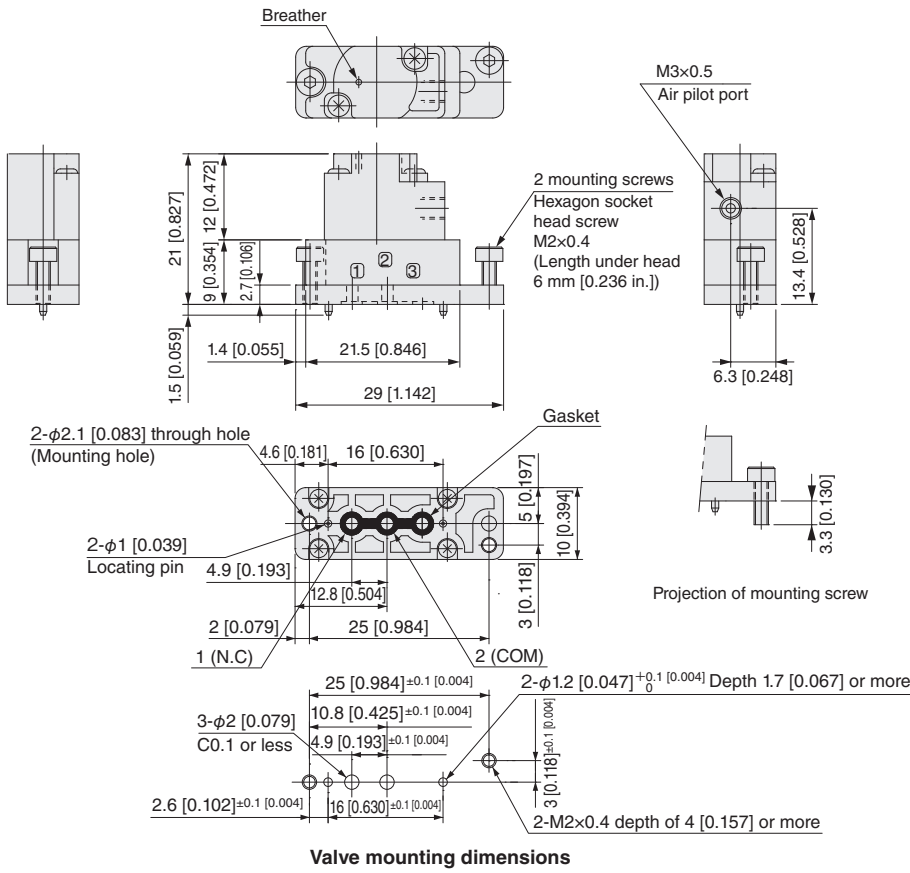

Base mounting with sub plate attached

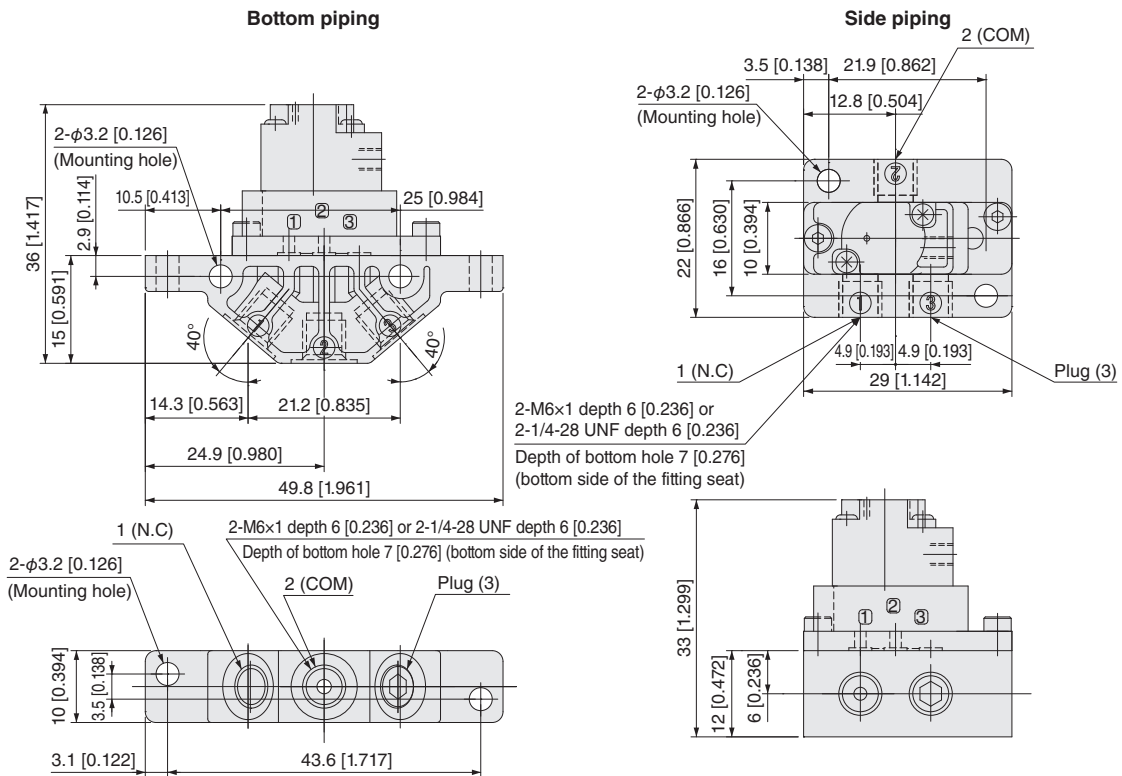

Air-operated valve

● PVRA16 3-port

Base mounting

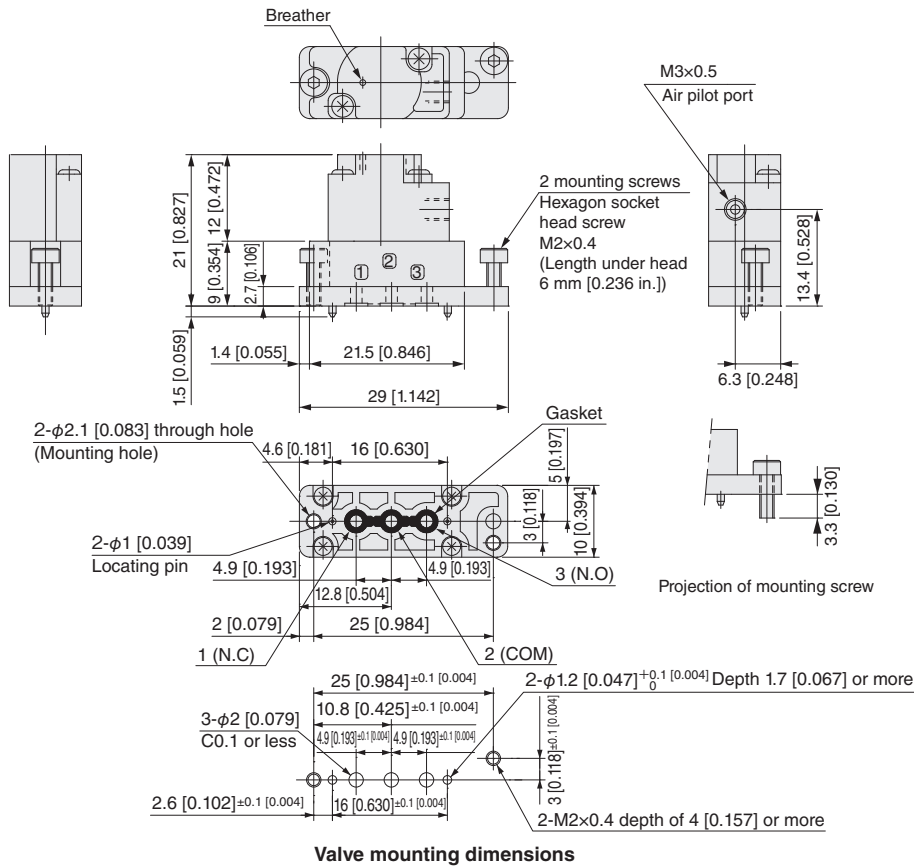

Base mounting with sub plate attached

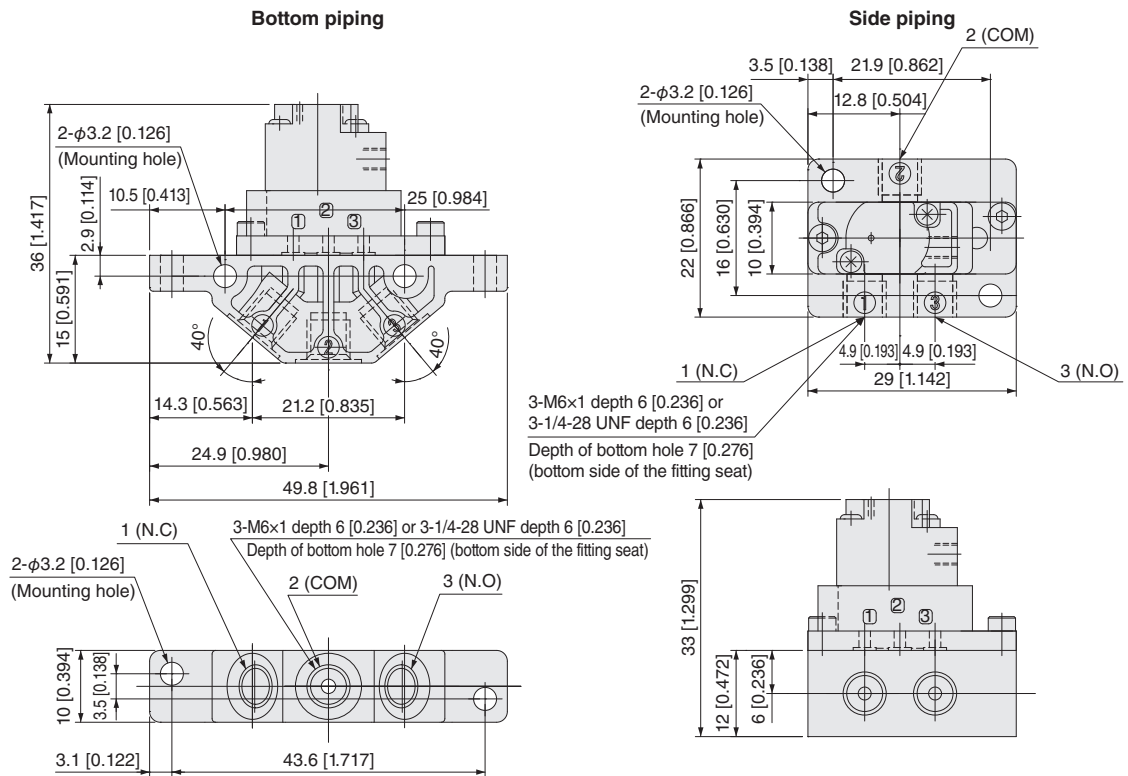

Solenoid valve

● PVR20-2 2-port, normally closed (NC)

Base mounting

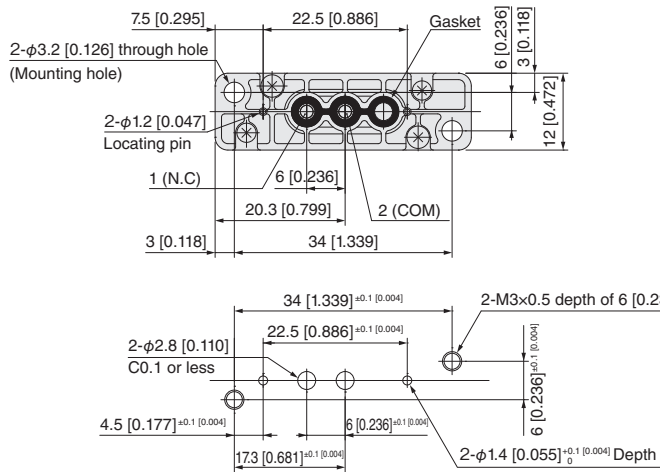
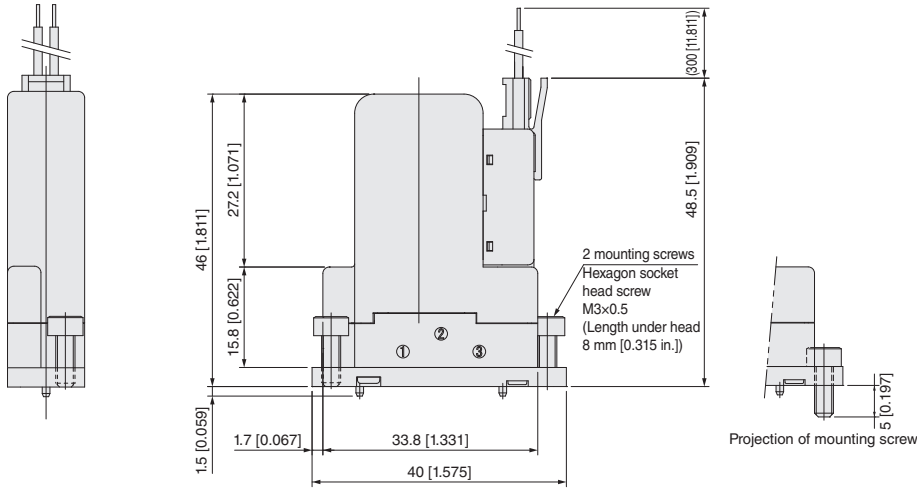

Valve mounting dimensions

Base mounting with sub plate attached

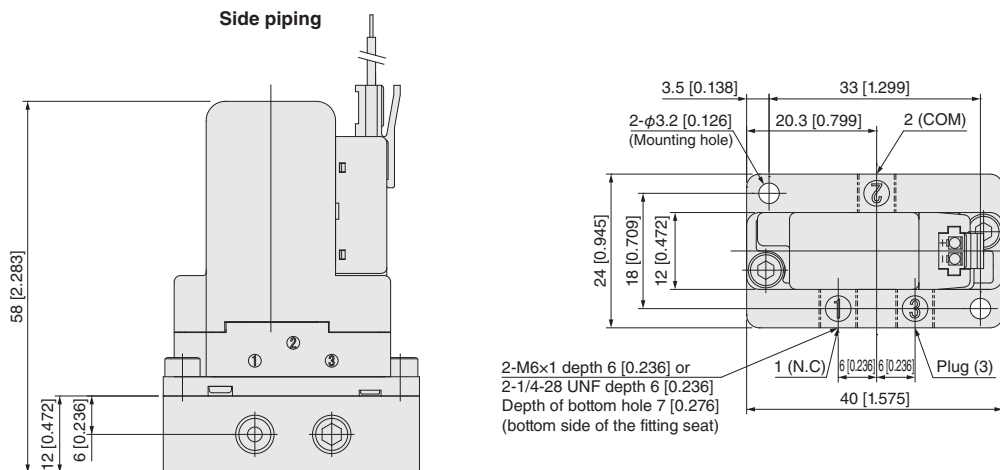



Solenoid valve

● PVR20-2 2-port, normally closed (NC)

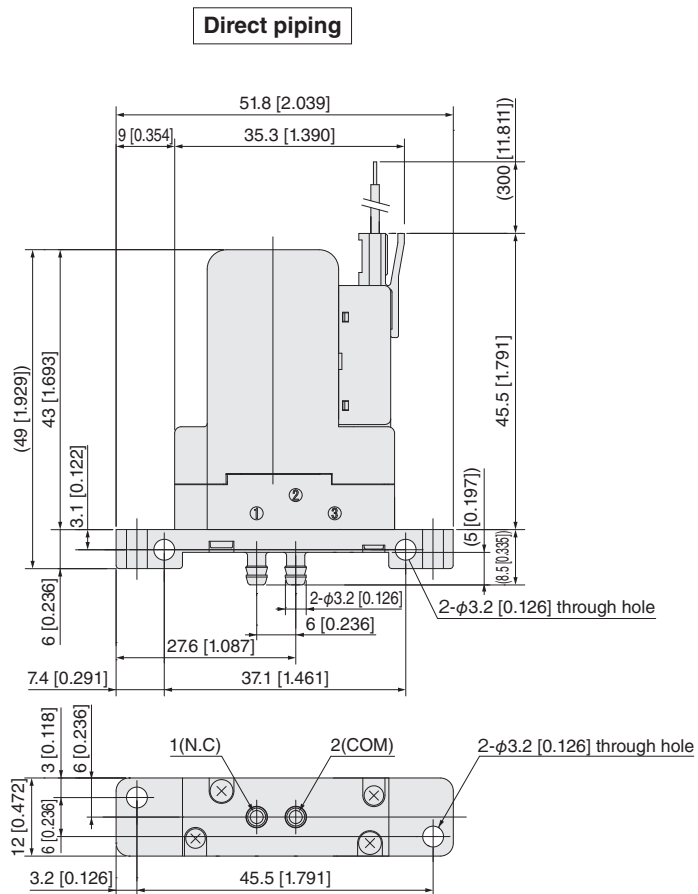

Solenoid valve

● PVR20 3-port

Base mounting

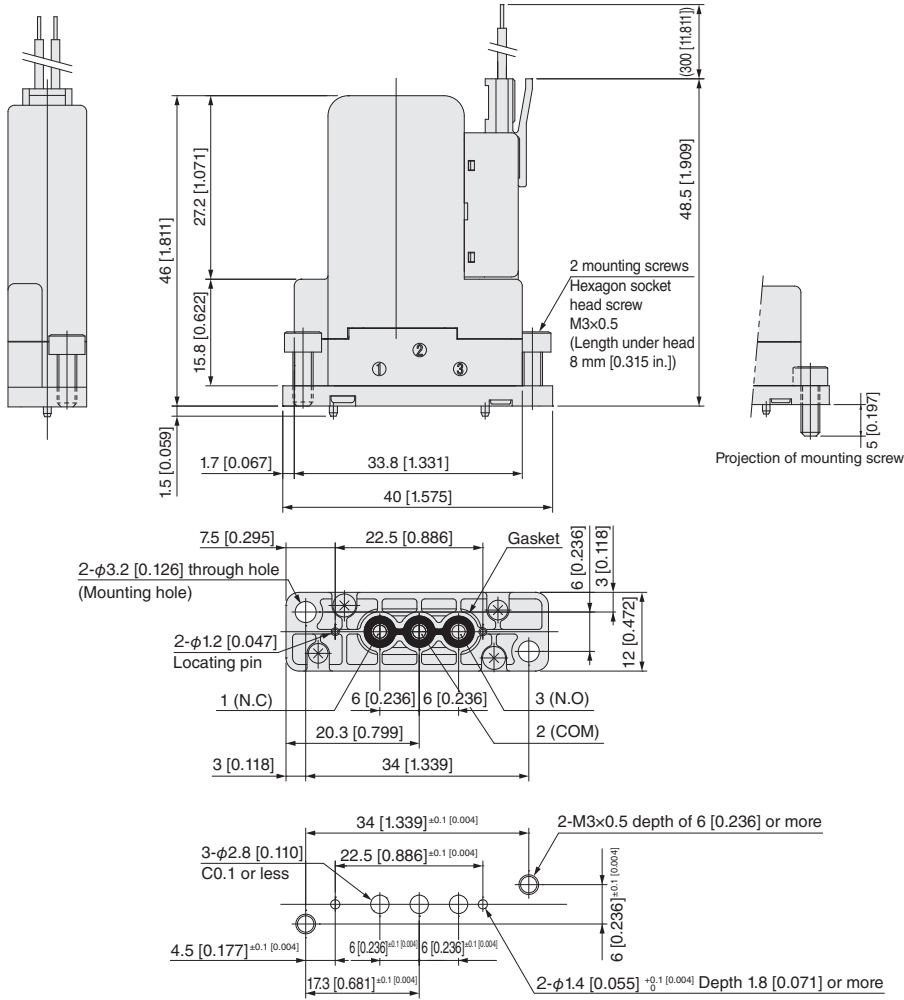

Valve mounting dimensions

Base mounting with sub plate attached

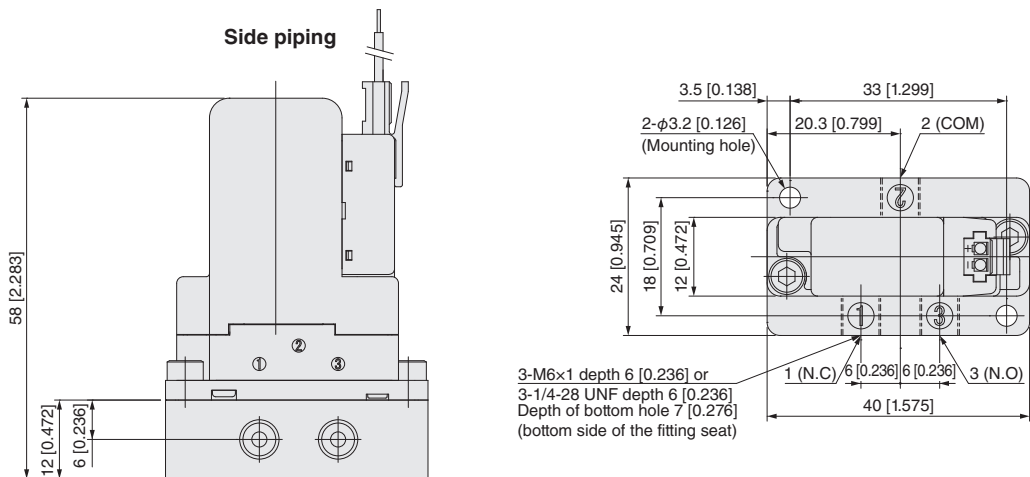



# Limited Warranty

KOGANEI CORP. warrants its products to be free from defects in material and workmanship subject to the following provisions.

**Warranty Period** The warranty period is 180 days from the date of delivery.

**Koganei Responsibility** If a defect in material or workmanship is found during the warranty period, KOGANEI CORP. will replace any part proved defective under normal use free of charge and will provide the service necessary to replace such a part.

**Limitations** ● This warranty is in lieu of all other warranties, expressed or implied, and is limited to the original cost of the product and shall not include any transportation fee, the cost of installation or any liability for direct, indirect or consequential damage or delay resulting from the defects.

● KOGANEI CORP. shall in no way be liable or responsible for injuries or damage to persons or property arising out of the use or operation of the manufacturer's product.

● This warranty shall be void if the engineered safety devices are removed, made inoperative or not periodically checked for proper functioning.

● Any operation beyond the rated capacity, any improper use or application, or any improper installation of the product, or any substitution upon it with parts not furnished or approved by KOGANEI CORP., shall void this warranty.

● This warranty covers only such items supplied by KOGANEI CORP. The products of other manufacturers are covered only by such warranties made by those original manufacturers, even though such items may have been included as the components.

The specifications are subject to change without notice.

URL: <http://www.koganeiusa.com>

E-mail: [sales@koganeiusa.com](mailto:sales@koganeiusa.com)



## KOGANEI CORPORATION

### OVERSEAS DEPARTMENT

3-11-28, Midori-cho, Koganei City, Tokyo 184-8533, Japan  
Tel: 81-42-383-7271 Fax: 81-42-383-7276

### KOGANEI INTERNATIONAL AMERICA, INC.

48860 Milmont Drive, Suite 108C, Fremont, California 94538  
Tel: 1-510-744-1626 Fax: 1-510-744-1676

### SHANGHAI KOGANEI INTERNATIONAL TRADING CORPORATION

Room 2606-2607, Tongda Venture Building No.1, Lane 600, Tianshan Road,  
Shanghai, 200051, China  
Tel: 86-21-6145-7313 Fax: 86-21-6145-7323

### TAIWAN KOGANEI TRADING CO., LTD.

Rm. 2, 13F., No88, Sec. 2, Zhongxiao E. Rd., Zhongzheng Dist., Taipei City 100,  
Taiwan (ROC)  
Tel: 886-2-2393-2717 Fax: 886-2-2393-2719

### KOGANEI KOREA CO., LTD.

6F-601, Tower Bldg., 1005, Yeongdeong-dong, Giheung-gu, Yongin-si, Gyeonggi-do,  
446-908, Korea  
Tel: 82-31-246-0414 Fax: 82-31-246-0415

### KOGANEI (THAILAND) CO., LTD.

3300/90, Tower B, Elephant Tower, 16th Fl., Phaholyothin Road, Chomphon,  
Chatuchak, Bangkok 10900, Thailand  
Tel: 66-2-937-4250 Fax: 66-2-937-4254

### KOGANEI AUTOMATION (MALAYSIA) SDN.BHD.

Suite 29-2, Level 29, Menara 1MK, No.1, Jalan Kiara, Mont Kiara  
50480, Kuala Lumpur, Malaysia  
Tel: 60-12-537-7086

### KOGANEI ASIA PTE. LTD.

69 Ubi Road 1, #05-18 Oxley Bizhub, Singapore 408731  
Tel: 65-6293-4512 Fax: 65-6293-4513