

Robot Joint

YAMAHA Robot Compatible



- Light weight and compact
- New designing is not required
- Quickly connect 5 types of actuators
 - Flat type air hand
 - 3 finger hand
 - Electric hand
 - Compliance light
 - Auto hand changer

Robot Joint

YAMAHA Robot Compatible

- Specialized connectors (robot joints) are available for mounting 5 series of Koganei actuators to YAMAHA SCARA robots.
- Man-hours can be greatly reduced from equipment setup by mounting robot joints to YAMAHA robots.

●YAMAHA Robot



YK series



YK-X series

●Electric hand mounting example



●Flat type air hand mounting example



●3 finger hand mounting example



< SCARA robot system example >

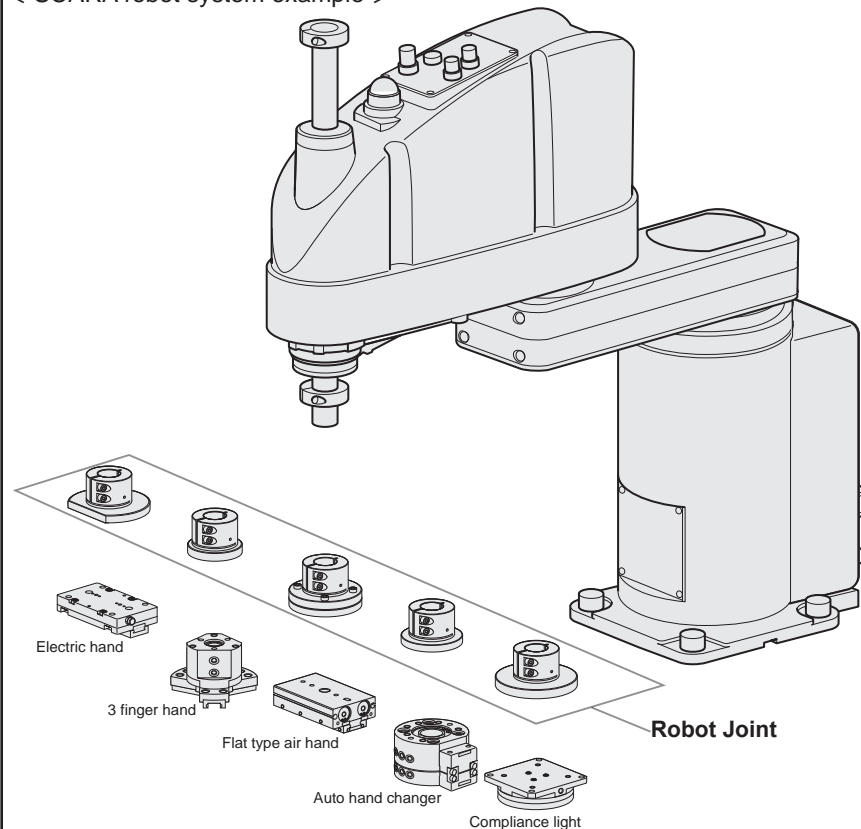

Order codes

● Robot joint models (for SCARA robots)

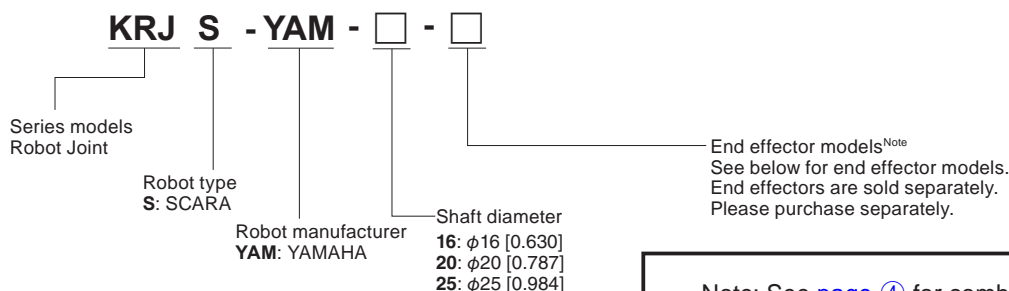







Note: See [page ④](#) for combinations of shaft diameters and end effector models.

● Compatibility table for shaft diameters and YAMAHA SCARA robot series

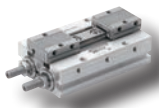
Shaft diameter (mm [in.])	Compatible robots
16 [0.630]	YK250XG
	YK250XGP
	YK300XGS
	YK350XG
	YK350XGP
	YK400XG
	YK400XGP
	YK400XGS
	YK400XR
	YK400XE
	YK500XGL
	YK500XGLP
	YK600XGL
	YK600XGLP

Shaft diameter (mm [in.])	Compatible robots
20 [0.787]	YK500XG
	YK500XGS
	YK510XE
	YK600XG
	YK600XGS
	YK610XE
	YK700XGL
	YK710XE
25 [0.984]	YK600XGH
	YK700XG
	YK700XGS
	YK800XG
	YK800XGS
	YK900XG
	YK900XGS
	YK1000XG
YK1000XGS	
YK1200X	

● End effector models

Flat type air hand	3 finger hand	Electric hand		Compliance light	Auto hand changer
					
AFDPG6	NHE1D16	EWHA6H	EW2H8	CPL34F	MJC3
AFDPG8	NHE1D20	EWHA12H	EW2H18	CPL54F	MJC10
AFDPG12	NHE1D25	EWHA24H	EW2H28	CPL70F	MJC20
AFDPG14		EWHA36H	EW2HL8	CPL90F	
AFDPG18		EWHA12A	EW2HL18		
AFDPGL6		EWHA24A	EW2HL28		
AFDPGL8		EWHA36A			
AFDPGL12					
AFDPGL14					
AFDPGL18					

Note: The above end effectors (5 series) are sold separately. Please purchase separately.

Order codes

Combination of shaft diameter and end effector model

SCARA robots

●Air hand (flat type air hand and 3 finger hand) combinations

Shaft diameter	Flat type air hand										3 finger hand		
	AFDPG6	AFDPG8	AFDPG12	AFDPG14	AFDPG18	AFDPGL6	AFDPGL8	AFDPGL12	AFDPGL14	AFDPGL18	NHE1D16	NHE1D20	NHE1D25
16 [0.630]	○	○	○	—	—	○	○	○	—	—	○	○	—
20 [0.787]	—	○	○	○	—	—	○	○	○	—	—	○	○
25 [0.984]	—	—	○	○	○	—	—	○	○	○	—	—	○

●Compliance light combinations

Shaft diameter	Compliance light			
	CPL34F	CPL54F	CPL70F	CPL90F
16 [0.630]	○	○	—	—
20 [0.787]	—	○	○	—
25 [0.984]	—	—	○	○

●Auto hand changer combinations

Shaft diameter	Auto hand changer		
	MJC3	MJC10	MJC20
16 [0.630]	○	○	—
20 [0.787]	—	○	—
25 [0.984]	—	○	○

●Electric hand combinations

Shaft diameter	Electric hand												
	EWHA6H	EWHA12H	EWHA24H	EWHA36H	EWHA12A	EWHA24A	EWHA36A	EW2H8	EW2H18	EW2H28	EW2HL8	EW2HL18	EW2HL28
16 [0.630]	○	○	—	—	○	○	○	○	○	—	○	○	—
20 [0.787]	—	○	○	○	○	○	○	—	○	○	—	○	○
25 [0.984]	—	○	○	○	○	○	○	—	○	○	—	○	○

Handling instructions and precautions

Installation procedure

1. SCARA robot (model : KRJS- □)

- ① Install the end effector and adapter plate.
If not included, the adapter plate is not required.
- ② Install the adapter plate (or end effector if the model does not include an adapter plate) and robot joint.
- ③ Insert the robot joint into the shaft, until the end.
- ④ We recommend the following procedure if the D-cut in the shaft is used for positioning.
The screw used in the tapped hole for positioning must be prepared by the customer.
【Recommended procedure when using tapped hole for positioning】
 - (1) Temporarily screw in the positioning screw, and then decide the position of the robot joint.
 - (2) Temporarily tighten the shaft clamp bolt to secure the robot joint.
 - (3) Remove the temporarily tightened positioning screw.
- ⑤ Tighten the shaft clamp bolt.
- ⑥ If the model has 2 shaft clamp bolts, alternately tighten them 3 times or more by the specified tightening torque.

Caution

If you cannot insert the shaft because the shaft hole in the robot joint is too narrow, then put a plate (a washer or flathead screwdriver can also be used) into the slit, then tighten a bolt (a fastening screw is also possible) into the threaded hole, so the shaft hole widens and the shaft can be inserted. After insertion is complete, remove the bolt and plate.

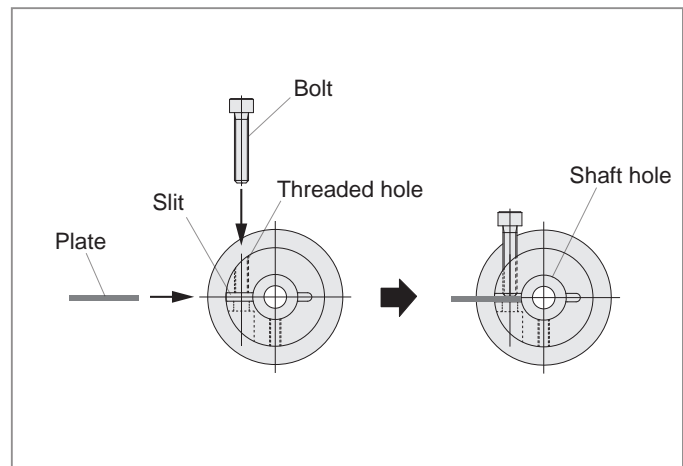
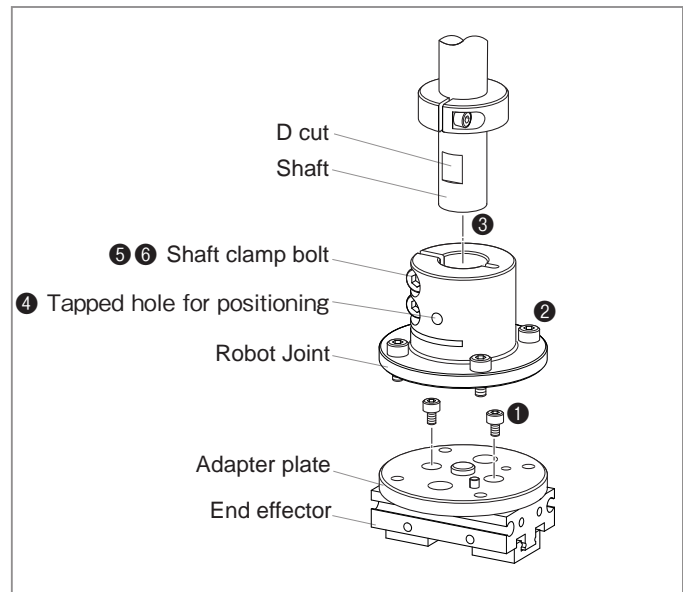

Handling instructions and precautions

Retaining force

● Robot Joint for SCARA robots

Shaft diameter (mm [in.])	Retaining force F (N)	Retaining torque T (N·m [in.lbf])
16 [0.630]	1400 [314.7]	14 [123.9]
20 [0.787]	3300 [741.9]	32 [283.2]
25 [0.984]	3600 [809.4]	46 [407.1]

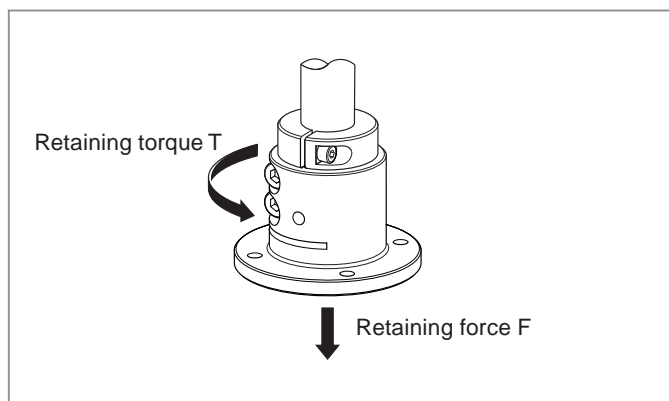

Material

Name of part	Material
Robot Joint	Aluminum alloy (alumite treatment)
Adapter plate	Aluminum alloy (alumite treatment)
Bolt	Stainless steel
Parallel pin	Stainless steel

Tightening torque

Screw size	Tightening torque (N·m [in.lbf])
M2.5	0.36 [3.186]
M3	0.63 [5.576]
M4	1.5 [13.277]
M5	3 [26.553]
M6	5.2 [46.025]

Caution

If there is a risk of bolts loosening due to shocks or vibrations, consider taking measures to prevent them from loosening.

Dimensions (mm [in.])

Shaft diameter : 16 [0.630]

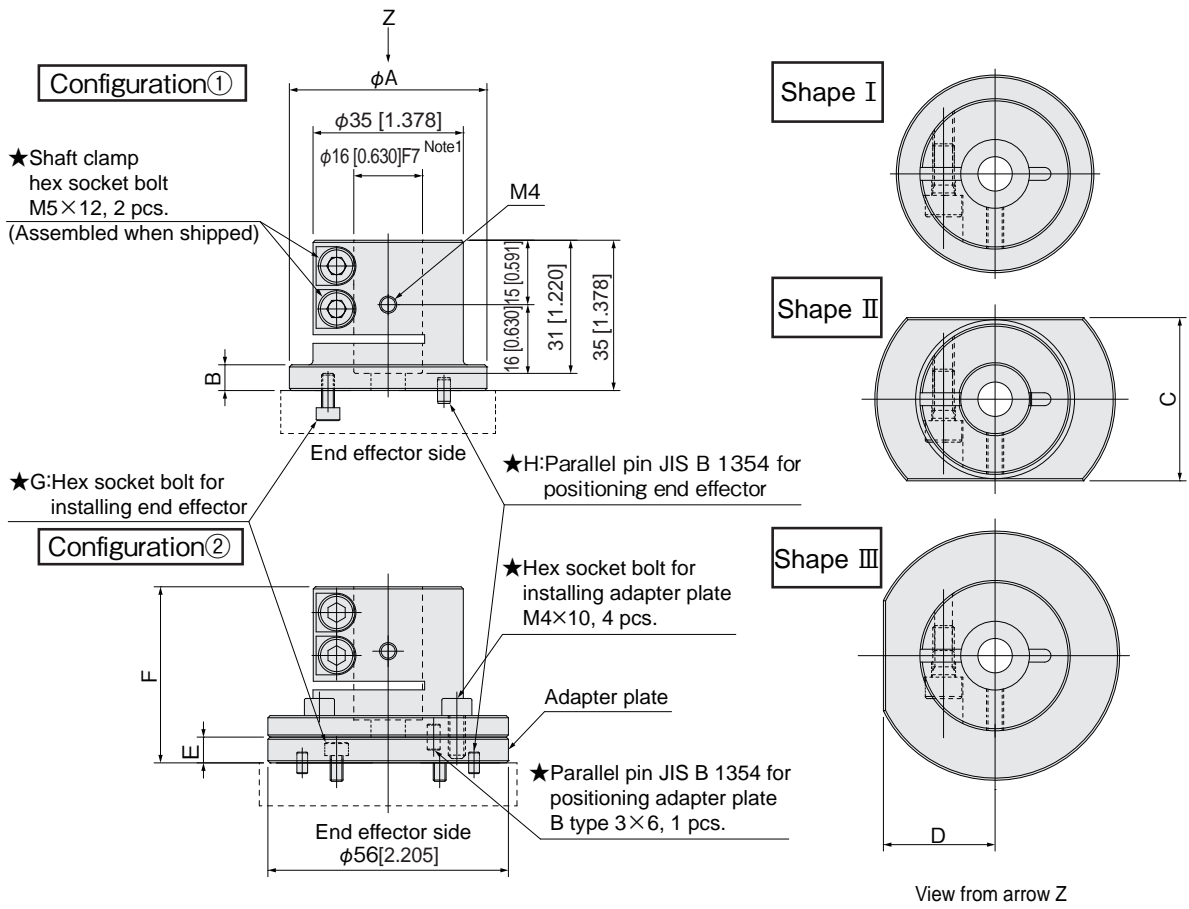

Dimensions (mm)

Shaft diameter : 16 [0.630]

● Air hand

Model	Mass (g [oz])		Configuration	Shape	Dimensions						Accessories			
	Product ^{Note 3}	End effector ^{Note 4}			A	B	C	D	E	F	G		H	
											Size	Count	Size	Count
KRJS-YAM-16-AFDPG6	85 [3.00]	52 [1.83]	①	I	35 [1.378]	-	-	-	-	-	M2.5×12	2	B type 2×4	2
KRJS-YAM-16-AFDPG8	160 [5.64]	86 [3.03]	②	I	56 [2.205]	5 [0.197]	-	-	6 [0.236]	41 [1.614]	M3×6	2	B type 2.5×5	2
KRJS-YAM-16-AFDPG12	160 [5.64]	200 [7.05]	②	I	56 [2.205]	5 [0.197]	-	-	6 [0.236]	41 [1.614]	M4×8	2	B type 3×6	2
KRJS-YAM-16-AFDPGL6	110 [3.88]	60 [2.12]	①	II	56 [2.205]	6 [0.236]	38 [1.496]	-	-	-	M2.5×12	2	B type 2×4	2
KRJS-YAM-16-AFDPGL8	125 [4.41]	135 [4.76]	①	II	78 [3.071]	6 [0.236]	38 [1.496]	-	-	-	M3×14	2	B type 2.5×5	2
KRJS-YAM-16-AFDPGL12	155 [5.47]	330 [11.64]	①	II	96 [3.780]	8 [0.315]	41 [1.614]	-	-	-	M4×18	2	B type 3×6	2
KRJS-YAM-16-NHE1D16	100 [3.53]	170 [6.00]	①	I	41 [1.614]	10 [0.394]	-	-	-	-	M3×35	3	B type 2×4	1
KRJS-YAM-16-NHE1D20	115 [4.06]	306 [10.79]	①	I	48 [1.890]	10 [0.394]	-	-	-	-	M3×40	3	B type 3×6	1

● Compliance light

Model	Mass (g [oz])		Configuration	Shape	Dimensions						Accessories			
	Product ^{Note 3}	End effector ^{Note 4}			A	B	C	D	E	F	G		H	
											Size	Count	Size	Count
KRJS-YAM-16-CPL34F	100 [3.53]	42 [1.48]	①	I	46 [1.811]	6 [0.236]	-	-	-	-	M3×8	4	B type 3×6	1
KRJS-YAM-16-CPL54F	115 [4.06]	130 [4.59]	①	I	54 [2.126]	6 [0.236]	-	-	-	-	M5×12	4	A type 4×6 ^{Note 5}	1

● Auto hand changer

Model	Mass (g [oz])		Configuration	Shape	Dimensions						Accessories			
	Product ^{Note 3}	End effector ^{Note 4}			A	B	C	D	E	F	G		H	
											Size	Count	Size	Count
KRJS-YAM-16-MJC3	85 [3.00]	65 [2.29]	①	I	35 [1.378]	-	-	-	-	-	M3×20	4	B type 2×5	1
KRJS-YAM-16-MJC10	125 [4.41]	235 [8.29]	①	I	54 [2.126]	9 [0.354]	-	-	-	-	M5×30	4	B type 4×8	1

● Electric hand

Model	Mass (g [oz])		Configuration	Shape	Dimensions						Accessories			
	Product ^{Note 3}	End effector ^{Note 4}			A	B	C	D	E	F	G		H	
											Size	Count	Size	Count
KRJS-YAM-16-EWHA6H	115 [4.06]	150 [5.29]	①	III	58 [2.283]	6 [0.236]	-	26 [1.024]	-	-	M3×10	4	B type 2×6	2
KRJS-YAM-16-EWHA12H	160 [5.64]	290 [10.23]	①	I	80 [3.150]	6 [0.236]	-	-	-	-	M3×16	4	B type 2×6	2
KRJS-YAM-16-EWHA12A	115 [4.06]	170 [6.00]	①	III	58 [2.283]	6 [0.236]	-	26 [1.024]	-	-	M3×12	4	B type 2×6	2
KRJS-YAM-16-EWHA24A	140 [4.94]	260 [9.17]	①	III	72 [2.835]	6 [0.236]	-	31 [1.220]	-	-	M3×12	4	B type 2×6	2
KRJS-YAM-16-EWHA36A	140 [4.94]	260 [9.17]	①	III	72 [2.835]	6 [0.236]	-	31 [1.220]	-	-	M3×12	4	B type 2×6	2
KRJS-YAM-16-EW2H8	115 [4.06]	90 [3.17]	①	III	58 [2.283]	6 [0.236]	-	26 [1.024]	-	-	M3×16	4	B type 2×6	2
KRJS-YAM-16-EW2H18	140 [4.94]	160 [5.64]	①	III	72 [2.835]	6 [0.236]	-	31 [1.220]	-	-	M4×18	4	B type 3×6	2
KRJS-YAM-16-EW2HL8	115 [4.06]	140 [4.94]	①	III	58 [2.283]	6 [0.236]	-	26 [1.024]	-	-	M3×16	4	B type 2×6	2
KRJS-YAM-16-EW2HL18	140 [4.94]	250 [8.82]	①	III	72 [2.835]	6 [0.236]	-	31 [1.220]	-	-	M4×18	4	B type 3×6	2

Note 1 : The F7 tolerance before machining of the slit. After machining of the slit, F7 may be inaccurate.

2 : In the drawings, the (★) bolts and pins are accessories.

3 : The product weight includes the weight of the bolts and parallel pins that are accessories.

4 : The end effectors are not included with these products. They must be ordered separately.

5 : The KRJS-YAM-16-CPL54F uses the old JIS A type parallel pin for positioning the end effector.

Dimensions (mm)

Shaft diameter : 20 [0.787]

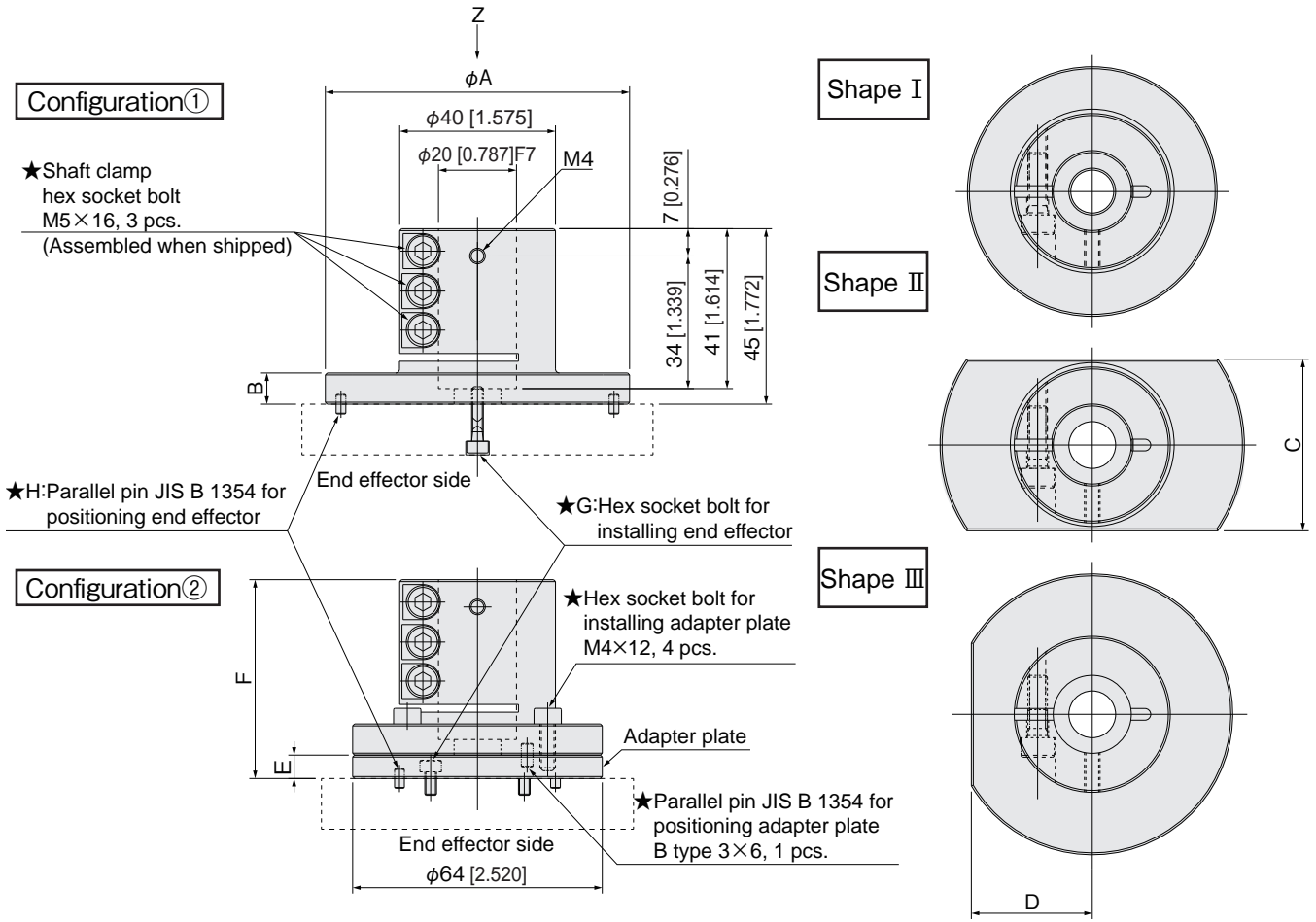

Dimensions (mm)

Shaft diameter : 20 [0.787]

● Air hand

Model	Mass (g [oz])		Configuration	Shape	Dimensions						Accessories			
	Product ^{Note 3}	End effector ^{Note 4}			A	B	C	D	E	F	G		H	
											Size	pcs	Size	pcs
KRJS-YAM-20-AFDPG8	250 [8.82]	86 [3.03]	②	I	64 [2.520]	8 [0.315]	-	-	6 [0.236]	51 [2.008]	M3×6	2	B type 2.5×5	2
KRJS-YAM-20-AFDPG12	250 [8.82]	200 [7.05]	②	I	64 [2.520]	8 [0.315]	-	-	6 [0.236]	51 [2.008]	M4×8	2	B type 3×6	2
KRJS-YAM-20-AFDPG14	265 [9.35]	390 [13.76]	②	I	64 [2.520]	8 [0.315]	-	-	8 [0.315]	53 [2.087]	M5×10	2	B type 3×6	2
KRJS-YAM-20-AFDPGL8	185 [6.53]	135 [4.76]	①	II	78 [3.071]	8 [0.315]	44 [1.732]	-	-	-	M3×14	2	B type 2.5×5	2
KRJS-YAM-20-AFDPGL12	205 [7.23]	330 [11.64]	①	II	96 [3.780]	8 [0.315]	44 [1.732]	-	-	-	M4×18	2	B type 3×6	2
KRJS-YAM-20-AFDPGL14	185 [6.53]	570 [20.11]	①	II	90 [3.543]	8 [0.315]	44 [1.732]	-	-	-	M5×14	2	B type 3×6	2
KRJS-YAM-20-NHE1D20	155 [5.47]	306 [10.79]	①	I	48 [1.890]	10 [0.394]	-	-	-	-	M3×40	3	B type 3×6	1
KRJS-YAM-20-NHE1D25	185 [6.53]	580 [20.46]	①	I	60 [2.362]	10 [0.394]	-	-	-	-	M4×45	3	B type 3×6	1

● Compliance light

Model	Mass (g)		Configuration	Shape	Dimensions						Accessories			
	Product ^{Note 3}	End effector ^{Note 4}			A	B	C	D	E	F	G		H	
											Size	pcs	Size	pcs
KRJS-YAM-20-CPL54F	205 [7.23]	130 [4.59]	①	I	72 [2.835]	8 [0.315]	-	-	-	-	M5×10	4	B type 4×8	1
KRJS-YAM-20-CPL70F	205 [7.23]	250 [8.82]	①	I	70 [2.756]	8 [0.315]	-	-	-	-	M5×14	4	B type 5×8	1

● Auto hand changer

Model	Mass (g)		Configuration	Shape	Dimensions						Accessories			
	Product ^{Note 3}	End effector ^{Note 4}			A	B	C	D	E	F	G		H	
											Size	pcs	Size	pcs
KRJS-YAM-20-MJC10	165 [5.82]	235 [8.29]	①	I	54 [2.126]	9 [0.354]	-	-	-	-	M5×30	4	B type 4×8	1

● Electric hand

Model	Mass (g)		Configuration	Shape	Dimensions						Accessories			
	Product ^{Note 3}	End effector ^{Note 4}			A	B	C	D	E	F	G		H	
											Size	pcs	Size	pcs
KRJS-YAM-20-EWHA12H	230 [8.11]	290 [10.23]	①	I	80 [3.150]	8 [0.315]	-	-	-	-	M3×16	4	B type 2×6	2
KRJS-YAM-20-EWHA24H	230 [8.11]	350 [12.35]	①	I	80 [3.150]	8 [0.315]	-	-	-	-	M3×16	4	B type 2×6	2
KRJS-YAM-20-EWHA36H	230 [8.11]	360 [12.70]	①	I	80 [3.150]	8 [0.315]	-	-	-	-	M3×16	4	B type 2×6	2
KRJS-YAM-20-EWHA12A	170 [6.00]	170 [6.00]	①	I	58 [2.283]	8 [0.315]	-	-	-	-	M3×12	4	B type 2×6	2
KRJS-YAM-20-EWHA24A	200 [7.05]	260 [9.17]	①	III	72 [2.835]	8 [0.315]	-	31 [1.220]	-	-	M3×12	4	B type 2×6	2
KRJS-YAM-20-EWHA36A	200 [7.05]	260 [9.17]	①	III	72 [2.835]	8 [0.315]	-	31 [1.220]	-	-	M3×12	4	B type 2×6	2
KRJS-YAM-20-EW2H18	200 [7.05]	160 [5.64]	①	III	72 [2.835]	8 [0.315]	-	31 [1.220]	-	-	M4×18	4	B type 3×6	2
KRJS-YAM-20-EW2H28	250 [8.82]	360 [12.70]	①	III	88 [3.465]	8 [0.315]	-	40 [1.575]	-	-	M4×25	4	B type 3×6	2
KRJS-YAM-20-EW2HL18	200 [7.05]	250 [8.82]	①	III	72 [2.835]	8 [0.315]	-	31 [1.220]	-	-	M4×18	4	B type 3×6	2
KRJS-YAM-20-EW2HL28	250 [8.82]	480 [16.93]	①	III	88 [3.465]	8 [0.315]	-	40 [1.575]	-	-	M4×25	4	B type 3×6	2

Note 1: The F7 tolerance before machining of the slit. After machining of the slit, F7 may be inaccurate.

2: In the drawings, the (★) bolts and pins are accessories.

3: The product weight includes the weight of the bolts and parallel pins that are accessories.

4: The end effectors are not included with these products. They must be ordered separately.

Dimensions (mm)

Shaft diameter : 25 [0.984]

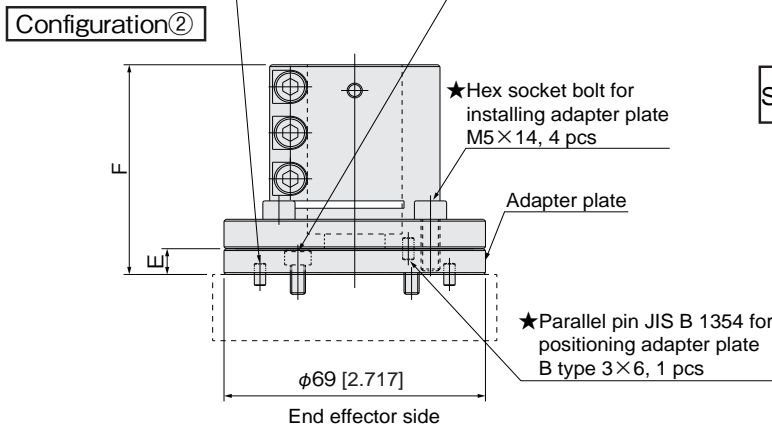
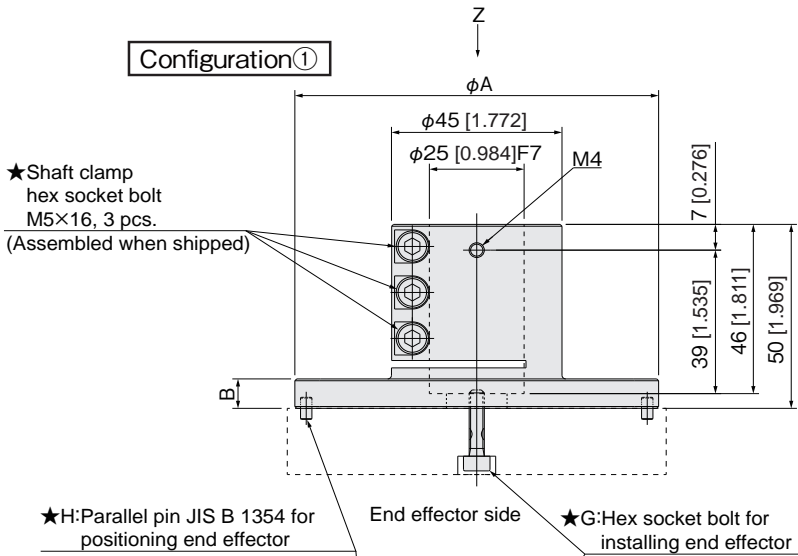

Shape I

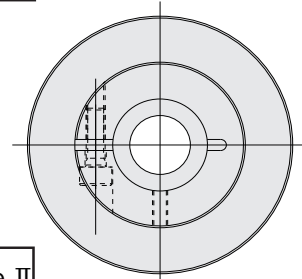

Shape II

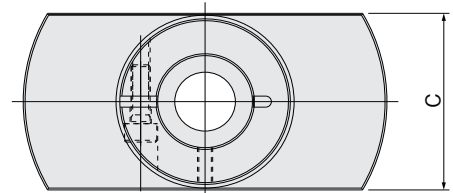

Shape III

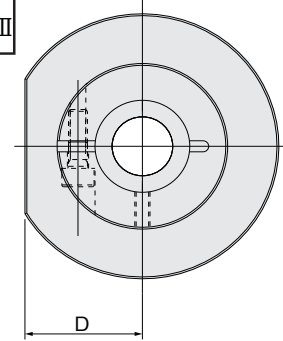

View from arrow Z

Dimensions (mm)

Shaft diameter : 25 [0.984]

● Air hand

Model	Mass (g)		Configuration	Shape	Dimensions						Accessories			
	Product ^{Note 3}	End effector ^{Note 4}			A	B	C	D	E	F	G		H	
											Size	pcs	Size	pcs
KRJS-YAM-25-AFDPG12	315 [11.11]	200 [7.05]	②	I	69 [2.717]	8 [0.315]	-	-	7 [0.276]	57 [2.244]	M4×8	2	B type 3×6	2
KRJS-YAM-25-AFDPG14	325 [11.46]	390 [13.76]	②	I	69 [2.717]	8 [0.315]	-	-	8 [0.315]	58 [2.283]	M5×10	2	B type 3×6	2
KRJS-YAM-25-AFDPG18	325 [11.46]	690 [24.34]	②	I	69 [2.717]	8 [0.315]	-	-	8 [0.315]	58 [2.283]	M5×10	2	B type 3×6	2
KRJS-YAM-25-AFDPL12	245 [8.64]	330 [11.64]	①	II	96 [3.780]	8 [0.315]	48 [1.890]	-	-	-	M4×18	2	B type 3×6	2
KRJS-YAM-25-AFDPL14	245 [8.64]	570 [20.11]	①	II	90 [3.543]	8 [0.315]	52 [2.047]	-	-	-	M5×14	2	B type 3×6	2
KRJS-YAM-25-AFDPL18	245 [8.64]	1020 [35.98]	①	II	90 [3.543]	8 [0.315]	52 [2.047]	-	-	-	M5×16	2	B type 3×6	2
KRJS-YAM-25-NHE1D25	215 [7.58]	580 [20.46]	①	I	60 [2.362]	10 [0.394]	-	-	-	-	M4×45	3	B type 3×6	1

● Compliance light

Model	Mass (g)		Configuration	Shape	Dimensions						Accessories			
	Product ^{Note 3}	End effector ^{Note 4}			A	B	C	D	E	F	G		H	
											Size	pcs	Size	pcs
KRJS-YAM-25-CPL70F	235 [8.29]	250 [8.82]	①	I	70 [2.756]	8 [0.315]	-	-	-	-	M5×14	4	B type 5×8	1
KRJS-YAM-25-CPL90F	305 [10.76]	460 [16.23]	①	I	90 [3.543]	8 [0.315]	-	-	-	-	M6×16	4	B type 6×8	1

● Auto hand changer

Model	Mass (g)		Configuration	Shape	Dimensions						Accessories			
	Product ^{Note 3}	End effector ^{Note 4}			A	B	C	D	E	F	G		H	
											Size	pcs	Size	pcs
KRJS-YAM-25-MJC10	195 [6.88]	235 [8.29]	①	I	54 [2.126]	9 [0.354]	-	-	-	-	M5×30	4	B type 4×8	1
KRJS-YAM-25-MJC20	240 [8.47]	470 [16.58]	①	I	70 [2.756]	9 [0.354]	-	-	-	-	M5×35	4	B type 5×8	1

● Electric hand

Model	Mass (g)		Configuration	Shape	Dimensions						Accessories			
	Product ^{Note 3}	End effector ^{Note 4}			A	B	C	D	E	F	G		H	
											Size	pcs	Size	pcs
KRJS-YAM-25-EWHA12H	260 [9.17]	290 [10.23]	①	I	80 [3.150]	8 [0.315]	-	-	-	-	M3×16	4	B type 2×6	2
KRJS-YAM-25-EWHA24H	260 [9.17]	350 [12.35]	①	I	80 [3.150]	8 [0.315]	-	-	-	-	M3×16	4	B type 2×6	2
KRJS-YAM-25-EWHA36H	260 [9.17]	360 [12.70]	①	I	80 [3.150]	8 [0.315]	-	-	-	-	M3×16	4	B type 2×6	2
KRJS-YAM-25-EWHA12A	200 [7.05]	170 [6.00]	①	I	58 [2.283]	8 [0.315]	-	-	-	-	M3×12	4	B type 2×6	2
KRJS-YAM-25-EWHA24A	235 [8.29]	260 [9.17]	①	III	72 [2.835]	8 [0.315]	-	31 [1.220]	-	-	M3×12	4	B type 2×6	2
KRJS-YAM-25-EWHA36A	235 [8.29]	260 [9.17]	①	III	72 [2.835]	8 [0.315]	-	31 [1.220]	-	-	M3×12	4	B type 2×6	2
KRJS-YAM-25-EW2H18	235 [8.29]	160 [5.64]	①	III	72 [2.835]	8 [0.315]	-	31 [1.220]	-	-	M4×18	4	B type 3×6	2
KRJS-YAM-25-EW2H28	285 [10.05]	360 [12.70]	①	III	88 [3.465]	8 [0.315]	-	40 [1.575]	-	-	M4×25	4	B type 3×6	2
KRJS-YAM-25-EW2HL18	235 [8.29]	250 [8.82]	①	III	72 [2.835]	8 [0.315]	-	31 [1.220]	-	-	M4×18	4	B type 3×6	2
KRJS-YAM-25-EW2HL28	285 [10.05]	480 [16.93]	①	III	88 [3.465]	8 [0.315]	-	40 [1.575]	-	-	M4×25	4	B type 3×6	2

Note 1: The F7 tolerance before machining of the slit. After machining of the slit, F7 may be inaccurate.

2: In the drawings, the (★) bolts and pins are accessories.

3: The product weight includes the weight of the bolts and parallel pins that are accessories.

4: The end effectors are not included with these products. They must be ordered separately.

MEMO

A series of horizontal dashed lines for writing.

Limited Warranty

KOGANEI CORP. warrants its products to be free from defects in material and workmanship subject to the following provisions.

Warranty Period The warranty period is 180 days from the date of delivery.

Koganei Responsibility If a defect in material or workmanship is found during the warranty period, KOGANEI CORP. will replace any part proved defective under normal use free of charge and will provide the service necessary to replace such a part.

Limitations ● This warranty is in lieu of all other warranties, expressed or implied, and is limited to the original cost of the product and shall not include any transportation fee, the cost of installation or any liability for direct, indirect or consequential damage or delay resulting from the defects.

● KOGANEI CORP. shall in no way be liable or responsible for injuries or damage to persons or property arising out of the use or operation of the manufacturer's product.

● This warranty shall be void if the engineered safety devices are removed, made inoperative or not periodically checked for proper functioning.

● Any operation beyond the rated capacity, any improper use or application, or any improper installation of the product, or any substitution upon it with parts not furnished or approved by KOGANEI CORP., shall void this warranty.

● This warranty covers only such items supplied by KOGANEI CORP. The products of other manufacturers are covered only by such warranties made by those original manufacturers, even though such items may have been included as the components.

The specifications are subject to change without notice.

URL: <http://www.koganeiusa.com>

E-mail: sales@koganeiusa.com



KOGANEI CORPORATION

OVERSEAS DEPARTMENT

3-11-28, Midori-cho, Koganei City, Tokyo 184-8533, Japan
Tel: 81-42-383-7271 Fax: 81-42-383-7276

KOGANEI INTERNATIONAL AMERICA, INC.

48860 Millmont Drive, Suite 108C, Fremont, California 94538
Tel : 1-510-744-1626 Fax : 1-510-744-1676

SHANGHAI KOGANEI INTERNATIONAL TRADING CORPORATION

RM2601-2602, Tongda Venture Building No.1, Lane 600, Tianshan Road, Shanghai, China (200051)
Tel: 86-21-6145-7313 Fax: 86-21-6145-7323

TAIWAN KOGANEI TRADING CO.,LTD

Rm. 2, 16F., No88, Sec. 2, Zhongxiao E. Rd., Zhongzheng Dist., Taipei City 100, Taiwan(ROC)
Tel: 886-2-2393-2717 Fax: 886-2-2393-2719

KOGANEI KOREA CO.,LTD

A-3001, Heungdeok IT Valley Bldg., Heungkeok 1-ro, 13, Giheung-gu, Yongin-si, Gyeonggi-do, 446-908, KOREA
Tel: 82-31-246-0414 Fax: 82-31-246-0415

KOGANEI (THAILAND) CO.,LTD

555 Rasa Tower 1, 12th Floor, Unit 1202 and 1207, Phaholyothin Road, Chatuchak, Bangkok 10900 Thailand
Tel: 66-2-937-4250 Fax: 66-2-937-4254

KOGANEI AUTOMATION (MALAYSIA) SDN, BHD.

Suite 29-2, Level 29, Menara 1MK, No.1, Jalan Kiara, Mont Kiara 50480, Kuala Lumpur, Malaysia
Tel: 60-12-537-7086

KOGANEI ASIA PTE. LTD.

69 Ubi Road 1, #05-18 Oxley Bizhub Singapore 408731
Tel: 65-6293-4512 Fax: 65-6293-4513