

I/O Terminal

Consolidates electrical signals from the end of devices and enables communication with higher-level systems

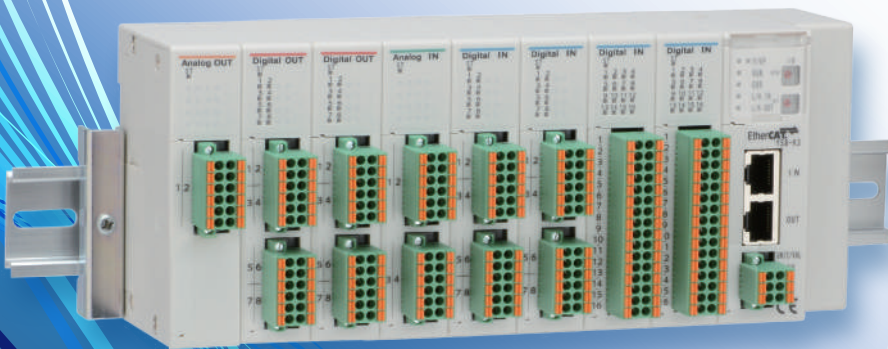

**Remote I/O function has been added
to the Solenoid Valve F10 and F15 series**

I/O Terminal

- The module configuration and expandability supports a wide variety of user requirements.
- The compact and slim shape reduces installation space.
- 2 mounting options available: DIN rail mounting and Direct mounting.
- Push-in connection allows easy wiring by simple wire insert.

Digital output

- 8 points — Sink type YS8-D8S
- Source type YS8-D8S-M

Analog output

- 2 points (switchable between 0-5 V, 0-10 V, and 0-20 mA)
- YS8-A2S

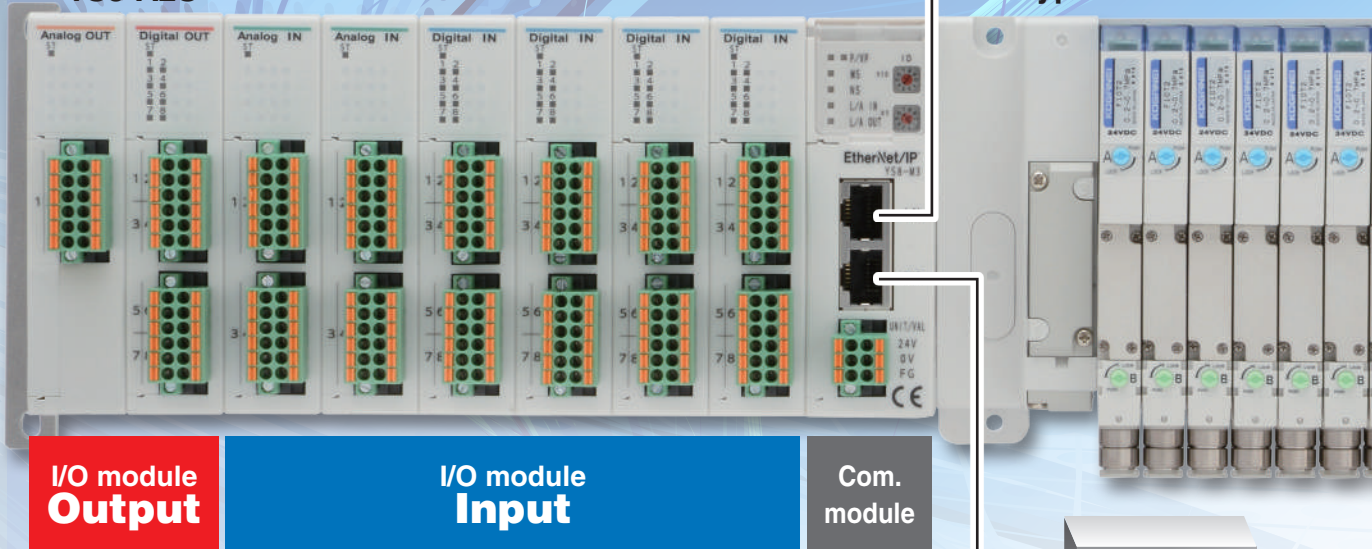

Digital input

- 8 points — NPN type YS8-D8N
- PNP type YS8-D8N-P
- 16 points^{Note} — YS8-D16N
- Note: 2-wire type only

Analog input

- 4 points (switchable between 0-5 V/0-10 V/0-20 mA)
- YS8-A4N

Communication module

EtherCAT input/output module supported YS8-K3

EtherNet/IP input/output module supported YS8-M3

Supported solenoid valve manifolds

F10 Series Split Type Manifold

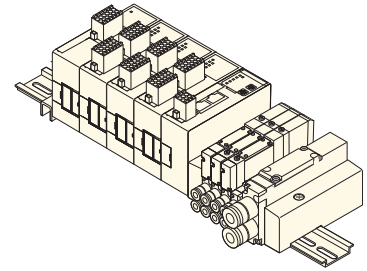

F10 Series Easy Assembly Type Manifold

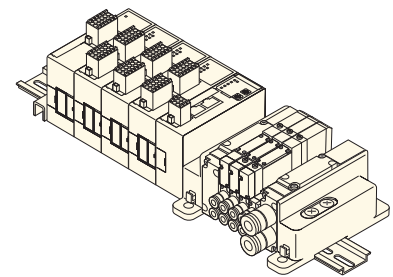

F15 Series Split Type Manifold

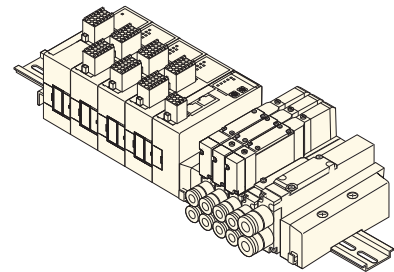

F15 Series Easy Assembly Type Manifold

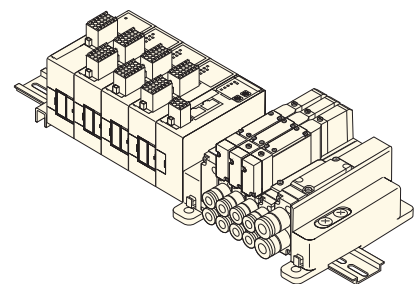

Output devices



Solenoid valve



Electro-pneumatic regulator

Others
 · Lamp
 · Relay
 · Buzzer



Input devices



Pressure switch



Cylinder sensor switch

Other
 · Proximity switch
 · Photoelectric switch
 · Limit switch

■ EtherNet/IP™ is a trademark of ODVA.

■ EtherCAT®, EtherCAT P®, and Safety over EtherCAT® are patented technologies and registered trademarks licensed by Beckhoff Automation GmbH (Germany).

 **Caution**

Regarding the handling and precautions of the product, make sure to read the "Safety Precautions" and "Handling Instruction and General Precautions" in the I/O Terminal User's Manual on Koganei's website before using the product.

2 mounting options available

Select from DIN rail mounting and Direct mounting (6 mounting holes on main body).

DIN rail mounting

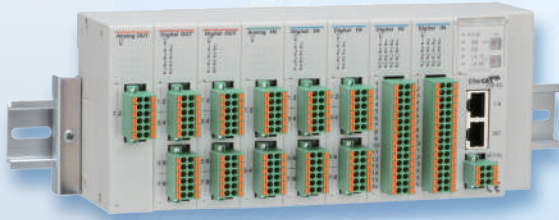

Direct mounting



Push-in connection supports wiring without using special tools.

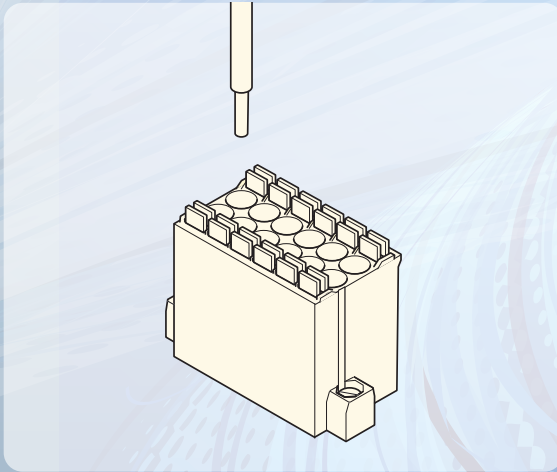

Wiring is possible by simply inserting* solid wires, or stranded wires with rod terminals.

No torque management or tightening is required.

* Insert the wire while pressing the orange button.

The compact design reduces installation space

I/O module
22.5 mm [0.886 in.]

Communication module
30 mm [1.181 in.]

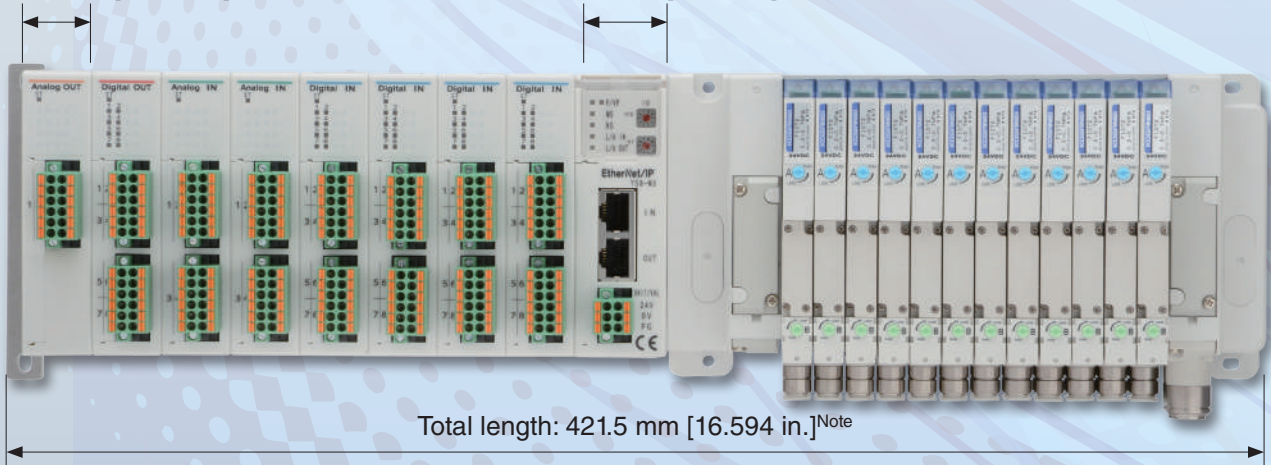

Note: The above total length is for 8 units of the I/O module, and 12 solenoid valves of the F10 Series Easy Assembly Type Manifold (without intermediate piping blocks).

I/O Terminal EtherNet/IP™ compatible

Communications network is all on the Ethernet!

You can organize field networks that are connected using various different standards into one single network. You can also consolidate information networks to create a vertically integrated production management system.

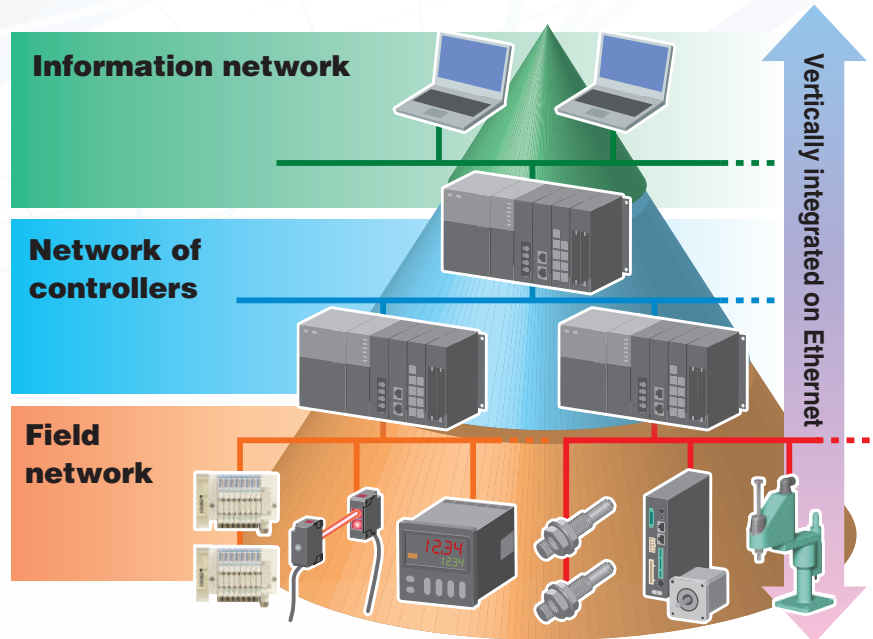

Various connection formats (example of connecting F10M8SJ-JR-M1 stn 1 to 8 F10T2-A1-DC24V)

Line format

All devices can be connected in a daisy chain.

<Features>

Total length of wiring can be reduced.

PLC (EtherNet/IP compatible equipment)

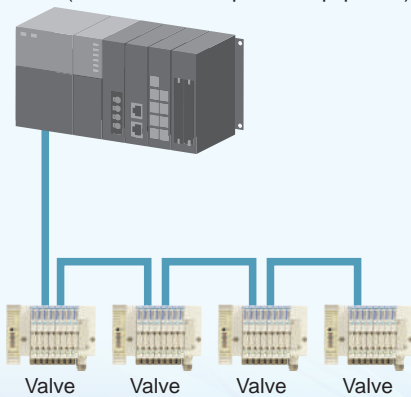

Star format

A radial network connection format can be done centered on a switching hub.

<Features>

Wiring formats are very flexible.

PLC (EtherNet/IP compatible equipment)

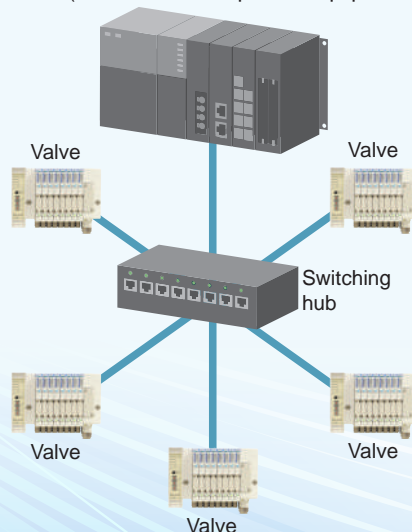

DLR (device level ring) format

All devices can be connected in a circular format.

<Features>

Highly reliable connection format. If one connection breaks, communications can be done around the circle in the opposite direction.

PLC (EtherNet/IP compatible equipment)

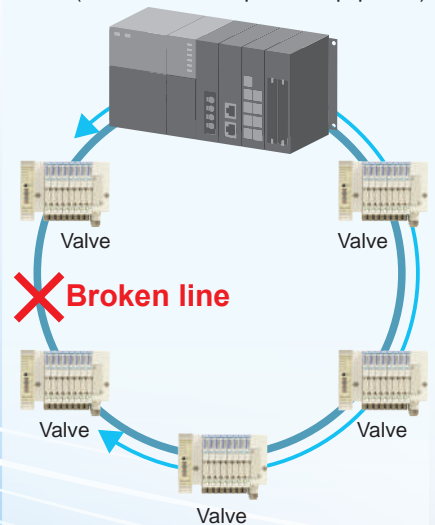

* Configure with devices that support DLR.

Specifications

General specifications

Item	Specifications
Operating temperature range	5 to 50 °C [41 to 122 °F]
Operating humidity range	35 to 85% RH (no condensation)
Operating atmosphere	No corrosive gases and no excessive dust
Vibration resistance	49.0 m/s ² [5 G]
Shock resistance	98.1 m/s ² [10 G]
Dielectric strength	1000 VAC for 1 minute (between all external terminals and the case)
Noise resistance	IEC61000-4-4 compliant, level 3
Insulation resistance	10 MΩ or more (between all external terminals and the case, using a 500 VDC insulation tester)
Standards	CE marking compliant

Communication module specifications

Item		Specifications	
Model		YS8-K3	YS8-M3
Number of connectable modules		8 or less	
Internal current consumption		100 mA or less (excluding input/output modules and solenoid valves)	
Input power supply		24 VDC ±10%, 2 A	
Output power supply		24 VDC ±10%, 2 A	
Transmission rate		100Mbps	10/100Mbps (Auto MDI/MDI-X supported)
Connection interface		RJ-45 8-pin modular connector x 2	
Topology		Line, star, and ring	
Transmission medium		Shielded twisted pair cables that are at least category 5 (100BASE-TX) are recommended	
Maximum cable length		100 m [328.0 ft]	
EtherCAT	Transmission/reception PDO size	Input: 40 bytes or less Output: 28 bytes or less	-
	Protocol	CoE	-
EtherNet/IP	I/O connection size	-	Input: 40 bytes Output: 28 bytes
	RPI	-	1 ms or more
	Conformance test	-	CT18 compliant
	Number of connections	-	8
	Functions	-	DLR, ACD, DHCP, BOOTP
Setting file		ESI file	EDS file
Mass		117 g [4.13 oz]	
Accessories		Power connector (YS8Z-CN6) x 1, I/O module connection lid (YS8Z-C) x 1	



K3: EtherCAT input/output module supported

M3: EtherNet/IP input/output module supported

Specifications

Digital input module specifications

Item	Specifications			
	Model	YS8-D16N	YS8-D8N	YS8-D8N-P
Input specifications	NPN		PNP	
Number of inputs	16	8		
Maximum sensor supply current	-	1 A/module		
Rated input current	7.5 mA or less (at 26.4 V) * Per input			
ON voltage/ON current	15 V or more/3.9 mA or more (During NPN input, between input terminal and +24 V) (During PNP input, between input terminal and 0 V)			
OFF voltage/OFF current	5 V or less/1 mA or less (During NPN input, between input terminal and +24 V) (During PNP input, between input terminal and 0 V)			
Input resistance	3.6 kΩ			
Protection function	Overcurrent detection			
Internal current consumption	10 mA or less (excluding sensor supply current)			
Mass	90 g [3.17 oz]			
Accessories	I/O connector (YS8Z-CN32) x 1 ¹ , I/O connector (YS8Z-CN12) x 2 ²			



Digital input x 8²



Digital input x 16¹

Analog input module specifications

Item	Specifications		
	Model	YS8-A4N	
Input specifications	Voltage	Current	
Number of inputs	4		
Maximum sensor supply current	1 A/module		
Rated input voltage/rated input current	15V	40mA	
Input impedance	1 MΩ	250 Ω	
Input signal range	0-5V/0-10V	0-20mA	
Resolution	12bit		
Conversion accuracy (25°C [77°F])	±0.5%F.S.		
Protection function	Overcurrent detection		
Internal current consumption	30 mA or less (excluding sensor supply current)		
Mass	90 g [3.17 oz]		
Accessories	I/O connector (YS8Z-CN12) x 2		



Analog Input x 4

Digital output module specifications

Item	Specifications		
	Model	YS8-D8S	YS8-D8S-M
Output specifications	Sink	Source	
Number of outputs	8		
Maximum load current	0.5 A/channel, 1 A/module		
Protection function	Overcurrent detection, output short-circuit protection		
Internal current consumption	30 mA or less (excluding sensor supply current)		
Mass	90 g [3.17 oz]		
Accessories	I/O connector (YS8Z-CN12) x 2		



Digital Output x 8

Analog output module specifications

Item	Specifications		
	Model	YS8-A2S	
Output specifications	Voltage	Current	
Number of outputs	2		
Maximum load current	1 A/module		
Load impedance	1 kΩ or more	600 Ω or less	
Output signal range	0-5V/0-10V	0-20mA	
Resolution	12bit		
Conversion accuracy (25°C [77°F])	±0.5%F.S.		
Protection function	Overcurrent detection, output short-circuit protection		
Internal current consumption	30 mA or less (excluding sensor supply current)		
Mass	90 g [3.17 oz]		
Accessories	I/O connector (YS8Z-CN12) x 1		



Analog output x 2

● **Communication module single unit**

YS8 - -

Mounting type

- Blank** : For mounting to Easy Assembly Type Manifold (with 2 small screws)
- BU** : For mounting to Split Type Manifold (with 2 small screws)
- RE** : end-block

Communication specifications

- K3** : EtherCAT. input/output module supported
- M3** : EtherNet/IP. input/output module supported

● **I/O module single unit**

Digital input x 8 (3-wire type)

YS8 - D8N -

Digital input specifications

- Blank** : NPN type
- P** : PNP type

Digital input x 16 (2-wire type)

YS8 - D16N

Digital Output x 8

YS8 - D8S -

Digital output specifications

- Blank** : Sink type (load side + common)
- M** : Source type (load side - common)

Analog Input x 4
(Switchable between 0-5 V/0-10 V/0-20 mA)

YS8 - A4N

Analog Output x 2
(Switchable between 0-5 V/0-10 V/0-20 mA)

YS8 - A2S

Order codes for additional parts

● Additional parts

• Connecting rods (2 pcs per set, small screws and washers included)

YS8Z -

Number of I/O modules
1: 1
⋮
8: 8



Note: Once you select a number of connecting rods, you cannot change it later. Be sure to select the number of connecting rods to suit the number of I/O modules to use.

• Mounting bracket

YS8Z -

DM: Direct mount (tapping screws included)
DN: DIN hardware (tapping screws included)

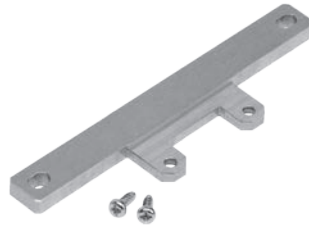

YS8Z-DM



YS8Z-DN

• Connector

YS8Z - CN

Number of pins
6 : YS8-K3/YS8-M3 power supply connector
12 : YS8-D8N-□/YS8-D8S-□/YS8-A4N connector
32 : YS8-D16N connector



Number of pins: 6



Number of pins: 12

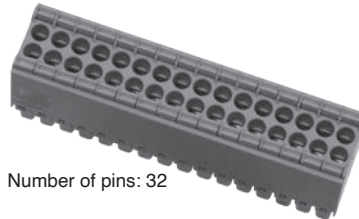

Number of pins: 32

• I/O module connection cover

YS8Z - C



• DIN rail (unit: 1 pc)

DIN -

Rail length
125 : 125 mm [4.921 in.]
⋮ (25 mm [0.984 in.] pitch)
700 : 700 mm [27.559 in.]

Internal circuit diagrams

YS8-D8N

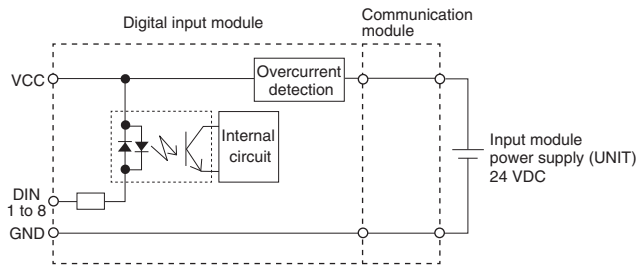

YS8-D8N-P

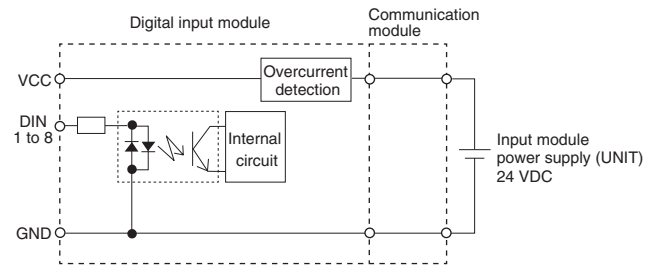

YS8-D16N

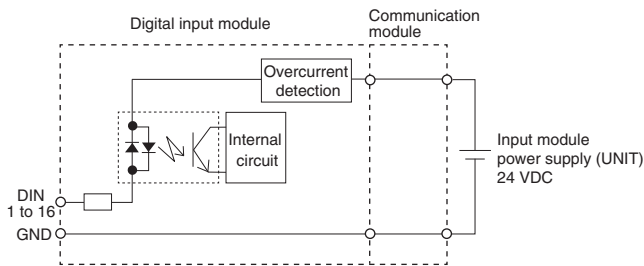

YS8-A4N

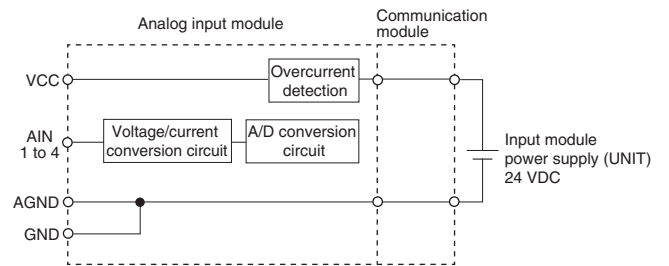

YS8-D8S

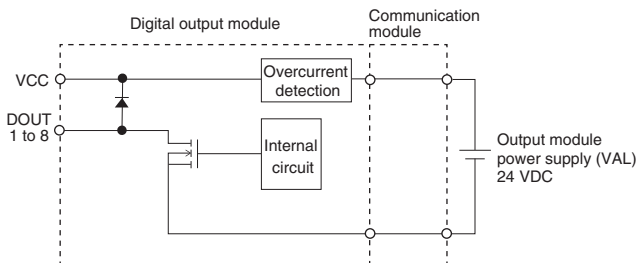

YS8-D8S-M

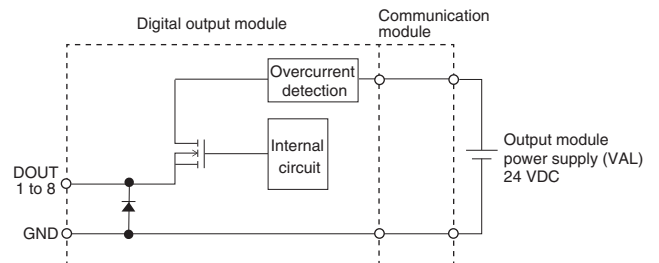

YS8-A2S

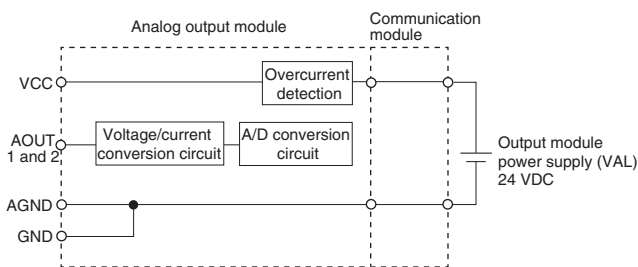

Mass

I/O terminal (not including valves)

g [oz]

Mounting option	Calculation of mass for each number of units
(Blank)	$258 [9.10] + (93 [3.28] \times n)$
-DN	$214 [7.55] + (93 [3.28] \times n)$
-DR	$235 [8.29] + (97 [3.42] \times n)$

Calculation example:

YS8EK3-8-DR
mod.1 YS8-D8N
mod.2 YS8-A4N
mod.3 YS8-D8S
mod.4 YS8-A2S

$$258 [9.10] + 97 [3.42] \times 4 = 646 \text{ g [22.79 oz]}$$

Mass to add for Split Type and Easy Assembly Type Manifolds / I/O terminal

Add to the calculated results of Split Type Manifold and Easy Assembly Type Manifold.

g [oz]

Mounting option	Calculation of mass for each number of units
(Blank)	$176 [6.21] + (93 [3.28] \times n)$
-DN	$154 [5.43] + (93 [3.28] \times n)$
-DR	$175 [6.17] + (97 [3.42] \times n)$

Calculation example:

F10M8XTJ-JR-K3-4-W-DR
stn.1 to 8 F10T1-A1 DC24V
mod.1 to 4 YS8-D8N

$$(92 [3.25] \times 8) + 310 [10.93] + 32 [1.13] + 175 [6.17] + (97 [3.42] \times 4) = 1641 \text{ g [57.88 oz]}$$

F10 Series

Split Type Manifold and Plugin Type / Serial Transmission Type mass (including valve single unit)

g [oz]

Supporting Types: Plugin Type Serial Transmission Type	Calculation of mass for each number of units			
	4 (A) and 2 (B) port output specifications			
	Female thread block	Dual use fitting block	φ4 fitting block	φ6 fitting block
	$(79 [2.79] \times n) + 120 [4.23]$	$(83 [2.93] \times n) + 120 [4.23]$	$(85 [3.00] \times n) + 120 [4.23]$	$(88 [3.10] \times n) + 120 [4.23]$

g [oz]

Mass to add			
Piping block specification			
Female thread block	Dual use fitting block	φ8 fitting block	φ10 fitting block
111 [3.92]	125 [4.41]	149 [5.26]	159 [5.61]

F10 Series

Easy Assembly Type Manifold and Plugin Type / Serial Transmission Type mass (including valve single unit)

g [oz]

Mounting option	Calculation of mass for each number of units			
	Outlet port specifications			
	Female thread block	Dual use fitting block	φ4 fitting block	φ6 fitting block
No symbol	$(86 [3.03] \times n) + 227 [8.01]$	$(90 [3.17] \times n) + 227 [8.01]$	$(92 [3.25] \times n) + 227 [8.01]$	$(95 [3.35] \times n) + 227 [8.01]$
-DN	$(86 [3.03] \times n) + 288 [10.16]$	$(90 [3.17] \times n) + 288 [10.16]$	$(92 [3.25] \times n) + 288 [10.16]$	$(95 [3.35] \times n) + 288 [10.16]$
-DR	$(88 [3.10] \times n) + 310 [10.93]$	$(92 [3.25] \times n) + 310 [10.93]$	$(94 [3.32] \times n) + 310 [10.93]$	$(97 [3.42] \times n) + 310 [10.93]$

g [oz]

Fitting specifications	Mass to add			
	Air supply and exhaust ports			
	Female thread block	Dual use fitting block	φ6 fitting block	φ8 fitting block
J □ M □	22 [0.78]	32 [1.13]	43 [1.52]	48 [1.69]
J □ D MD	26 [0.92]	46 [1.62]	68 [2.40]	78 [2.75]
J □ T MT	31 [1.09]	61 [2.15]	94 [3.32]	109 [3.84]

When mounting the block plate, subtract 50 g [1.76 oz] per series from the above calculation result.

When mounting **F10** □ **T0** products, subtract 10 g [0.35 oz] per unit from the above calculation result.

Mass

F15 Series

Split Type Manifold and Plugin Type / Serial Transmission Type mass (including valve single unit)

g [oz]

Supporting Types: Plugin Type Serial Transmission Type	Calculation of mass for each number of units			
	4 (A) and 2 (B) port output specifications			
	Female thread block	Dual use fitting block	φ6 fitting block	φ8 fitting block
	(177 [6.24] x n) + 249 [8.78]	(187 [6.60] x n) + 249 [8.78]	(198 [6.98] x n) + 249 [8.78]	(203 [7.16] x n) + 249 [8.78]

g [oz]

Mass to add			
Piping block specification			
Female thread block	Dual use fitting block	φ8 fitting block	φ10 fitting block
153 [5.40]	167 [5.89]	191 [6.74]	201 [7.09]

F15 Series

Easy Assembly Type Manifold and Plugin Type / Serial Transmission Type mass (including valve single unit)

g [oz]

Mounting option	Calculation of mass for each number of units			
	Outlet port specifications			
	Female thread block	Dual use fitting block	φ6 fitting block	φ8 fitting block
No symbol	(189 [6.67] x n) + 306 [10.79]	(199 [7.02] x n) + 306 [10.79]	(210 [7.41] x n) + 306 [10.79]	(215 [7.58] x n) + 306 [10.79]
-DN	(189 [6.67] x n) + 369 [13.02]	(199 [7.02] x n) + 369 [13.02]	(210 [7.41] x n) + 369 [13.02]	(215 [7.58] x n) + 369 [13.02]
-DR	(192 [6.77] x n) + 391 [13.79]	(201 [7.09] x n) + 391 [13.79]	(213 [7.51] x n) + 391 [13.79]	(218 [7.69] x n) + 391 [13.79]

g [oz]

Fitting specifications	Mass to add			
	Mass to add for air supply and exhaust ports			
	Female thread block	Dual use fitting block	φ8 fitting block	φ10 fitting block
J□ M□	34 [1.20]	48 [1.69]	72 [2.54]	82 [2.89]
J□D MD	44 [1.55]	72 [2.54]	120 [4.23]	140 [4.94]
J□T MT	- 27 [0.95]	15 [0.53]	87 [3.07]	117 [4.13]

When mounting the block plate, subtract 100 g [3.53 oz] per series from the above calculation result.

When mounting **F15□T0** products, subtract 13 g [0.46 oz] per series from the above calculation result.

Order codes for F10 Series Split Manifold with I/O Terminal

Manifold output specification

With dual use fitting blocks (base piping type)

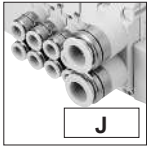

With selectable fittings (base piping type)

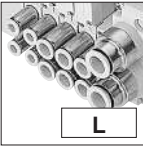

Outlet port fitting F10: $\phi 4$, $\phi 6$

Outlet port should be selected in accordance with the manifold fitting specification.

With female thread blocks (base piping type)

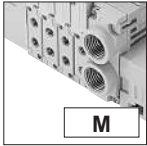

Outlet port female thread F10: M5 x 0.8

With plates (direct piping type)



Pilot specification

Blank

Internal pilot manifold

G

External pilot manifold

Piping block specification (air supply and exhaust)

Dual size fitting block

- JR : Dual use fitting, right-side mounting^{Note12}
 - JL : Dual use fitting, left-side mounting^{Note12}
 - JD : Dual use fitting, both-side mounting^{Note12}
- Fitting size (1(P), 3, 5(R) ports), $\phi 8$, $\phi 10$

Female thread block

- MR : Female thread, right-side mounting^{Note12}
 - ML : Female thread, left-side mounting^{Note12}
 - MD : Female thread, both-side mounting^{Note12}
- Female thread size (1(P), 3, 5(R) ports), Rc1/4

Female thread block

- MRH : Female thread, right-side mounting^{Note13}
 - MLH : Female thread, left-side mounting^{Note13}
 - MDH : Female thread, both-side mounting^{Note13}
- Female thread size (1(P), 3, 5(R) ports), NPT1/4

Single use fitting block

- J5R : Single use fitting, right-side mounting^{Note12}
 - J5L : Single use fitting, left-side mounting^{Note12}
 - J5D : Single use fitting, both-side mounting^{Note12}
 - J6R : Single use fitting, right-side mounting^{Note12}
 - J6L : Single use fitting, left-side mounting^{Note12}
 - J6D : Single use fitting, both-side mounting^{Note12}
- Fitting size (1(P), 3, 5(R) ports), $\phi 8$
- Fitting size (1(P), 3, 5(R) ports), $\phi 10$

Wiring and communication specifications

K3 : For EtherCAT (32 outputs) Input/output module supported

M3 : EtherNet/IP (32 outputs) Input/output module supported

Module number specifications

Blank : No I/O modules (Only communication modules)
1 to 8 : Number of I/O modules mounted 8 max.

Caution

When entering the order codes for input/output modules, indicate the input/output modules after indicating the mounted valves. For details of how to indicate input/output modules, see Module (mod.1, etc.) in I/O Terminal Order Codes on [page 7](#).

Valve size

F10M 10 mm [0.394 in.] width

Valve size

F10 Standard type
F10L Low-current type

Wiring connection specification

Blank

Packed wiring:
 Wiring is made in accordance with the mounted valve specifications.

-W

Double wiring:
 Wiring is always for the double solenoid, regardless of the specifications of the mounted valve.

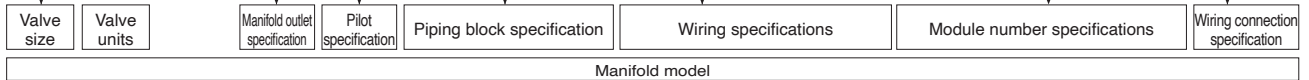

		Manifold model						
Base piping type	Manifold outlet specification	Pilot specification	Piping block specification	Wiring specifications	Module number specifications	Wiring connection specification	Valve size	
Base piping type	T (*Rc)	J M	Blank G	-JR -JL -JD -MR -ML -MD -J5R -J6R -J5L -J6L -J5D -J6D	-K3 -M3	Blank -1~8	Blank -W	
Base piping type selectable fitting	F10M 2 · · · □ Note 1	L	Blank G	-JR ^{Note12} -JL ^{Note12} -JD ^{Note12} -MR ^{Note12} -ML ^{Note12} -MD ^{Note12} -MRH ^{Note13} -MLH ^{Note13} -MDH ^{Note13} -J5R ^{Note12} -J6R ^{Note12} -J5L ^{Note12} -J6L ^{Note12} -J5D ^{Note12} -J6D ^{Note12}	-K3 -M3	Blank -1~8	Blank -W	
Direct piping type	TH (*NPT)	Blank	Blank G	-JR ^{Note12} -JL ^{Note12} -JD ^{Note12} -MR ^{Note12} -ML ^{Note12} -MD ^{Note12} -MRH ^{Note13} -MLH ^{Note13} -MDH ^{Note13} -J5R ^{Note12} -J6R ^{Note12} -J5L ^{Note12} -J6L ^{Note12} -J5D ^{Note12} -J6D ^{Note12}	-K3 -M3	Blank -1~8	Blank -W	

- Notes: 1. For maximum number of units, see [page 15](#) Quick Reference Chart of Maximum Number of Manifold Valves for Different Wiring Specifications.
 2. Valve mounting location is from the left, with the solenoid on top, and the 4(A), 2(B) port side in front.
 3. When selecting J, M, or L (base piping type) for the manifold outlet specifications, always enter -A1 (with plate) for the valve outlet type.
 4. The block-off plate wiring is always double wiring (allocated 2 control pins at 1 str.), regardless of the wiring connection specification. The block-off plate wiring can be made as wiring for a single solenoid. Add -1W to the end of the block-off plate order code in the case. For details, contact a Koganei sales office.
 5. When the valve specification is T1 or T2, the manual override lever is placed only on the A side.

Valve specification

- T0:** 2-position, for single solenoid only
- T1:** 2-position, single solenoid specification
- T2:** 2-position, double solenoid specification
- T3:** 3-position, closed center
- T4:** 3-position, exhaust center
- T5:** 3-position, pressure center
- TA:** Tandem 3-port (NC and NO)^{Note 9}
- TB:** Tandem 3-port (NO and NO)^{Note 9}
- TC:** Tandem 3-port (NC and NO)^{Note 9}

Operation type

Blank

Internal pilot type^{Note 7}

G

External pilot type^{Note 8}
(for positive pressure)

* No vacuum valve can be mounted.

Manual override

Manual override button



Manual override lever^{Note 5}



Valve outlet type

-A1 With plate^{Note 3}
(base piping type)

5-port specification

-FJ With dual use fitting block **F10:** φ4, φ6
(direct piping type)

-FJ5 With single use fitting block **F10:** φ4
(direct piping type)

-FJ6 With single use fitting block **F10:** φ6
(direct piping type)

-FM With female thread block **F10:** M5 x 0.8
(direct piping type)

-FMH With female thread block^{Note 13}
(direct piping type) **F10:** 10-32UNF

3-port specification

-FJ5A With single use fitting block,
normally closed (NC) **F10:** φ4
(direct piping type)

-FJ5B With single use fitting block,
normally open (NO) **F10:** φ4
(direct piping type)

-FJ6A With single use fitting block,
normally closed (NC) **F10:** φ6
(direct piping type)

-FJ6B With single use fitting block,
normally open (NO) **F10:** φ6
(direct piping type)

-FMA With female thread block,
normally closed (NC) **F10:** M5 x 0.8
(direct piping type)

-FMAH With female thread block,
normally closed (NC)^{Note 12}
(direct piping type) **F10:** 10-32UNF

-FMB With female thread block,
normally open (NO) **F10:** M5 x 0.8
(direct piping type)

-FMBH With female thread block,
normally open (NO)^{Note 13}
(direct piping type) **F10:** 10-32UNF



The 3-port specifications are only available in the valve specification **T0**, **T1**, and **T2**.

Manifold fitting specification

5-port specification

-J5 With single use fitting block **F10:** φ4
(base piping type)

-J6 With single use fitting block **F10:** φ6
(base piping type)

-M With female thread block **F10:** M5 x 0.8
(base piping type)

-MH With female thread block^{Note 11}
(base piping type) **F10:** 10-32UNF

3-port specification

-J5A With single use fitting block,
normally closed (NC) **F10:** φ4
(base piping type)

-J5B With single use fitting block,
normally open (NO) **F10:** φ4
(base piping type)

-J6A With single use fitting block,
normally closed (NC) **F10:** φ6
(base piping type)

-J6B With single use fitting block,
normally open (NO) **F10:** φ6
(base piping type)

-MA With female thread block,
normally closed (NC) **F10:** M5 x 0.8
(base piping type)

-MAH With female thread block,
normally closed (NC)^{Note 13}
(base piping type) **F10:** 10-32UNF

-MB With female thread block,
normally open (NO) **F10:** M5 x 0.8
(base piping type)

-MBH With female thread block,
normally open (NO)^{Note 13}
(base piping type) **F10:** 10-32UNF



The 3-port specifications are only available in the valve specification **T0**, **T1**, and **T2**.

Back pressure prevention valve

Blank

No back pressure prevention valve

-E2

With back pressure prevention valve^{Note 10}

Individual air supply and exhaust spacer

Blank: No spacer

-PPM: Individual air supply spacer
(with M5 female thread for F10)

-PRM: Individual exhaust spacer
(with M5 female thread for F10)

Station	Valve size	Valve specification	Operation type	Manual override	Valve outlet type	Manifold fitting specification	Back pressure prevention valve	Individual air supply and exhaust spacer	Port isolator	Voltage
---------	------------	---------------------	----------------	-----------------	-------------------	--------------------------------	--------------------------------	--	---------------	---------

Mounting valve model										
stn. 1 : : stn. □ Note 2	F10 F10L	T0 T3 TA ^{Note 9} T1 T4 TB ^{Note 9} T2 T5 TC ^{Note 9}	Blank ^{Note 7} G ^{Note 8}	Blank -R ^{Note 5}	-A1 ^{Note 3}		Blank -E2 ^{Note 10}	Blank -PPM -PRM	Blank -SP ^{Note 6} -SR ^{Note 6} -SA ^{Note 6}	DC24V
F10 BPP (for block-off plate) ^{Note 4}										
stn. 1 : : stn. □ Note 2	F10 F10L	T0 T3 TA ^{Note 9} T1 T4 TB ^{Note 9} T2 T5 TC ^{Note 9}	Blank ^{Note 7} G ^{Note 8}	Blank -R ^{Note 5}	-A1 ^{Note 3}	-J5 ^{Note 12} -J6A ^{Note 12} -J6 ^{Note 12} -J6B ^{Note 12} -M ^{Note 12} -MA ^{Note 12} -MH ^{Note 11} -MAH ^{Note 13} -J5A ^{Note 12} -MB ^{Note 12} -J5B ^{Note 12} -MBH ^{Note 13}	Blank -E2 ^{Note 10}	Blank -PPM -PRM	Blank -SP ^{Note 6} -SR ^{Note 6} -SA ^{Note 6}	DC24V
F10 BPP (for block-off plate) ^{Note 4}										
stn. 1 : : stn. □ Note 2	F10 F10L	T0 T3 TA ^{Note 9} T1 T4 TB ^{Note 9} T2 T5 TC ^{Note 9}	Blank ^{Note 7} G ^{Note 8}	Blank -R ^{Note 5}	-FJ ^{Note 12} -FJ6A ^{Note 12} -FJ5 ^{Note 12} -FJ6B ^{Note 12} -FM ^{Note 12} -FMA ^{Note 12} -FMH ^{Note 13} -FMAH ^{Note 13} -FMB ^{Note 12} -FMBH ^{Note 11} -FJ5A ^{Note 12} -FJ5B ^{Note 12}		Blank -E2 ^{Note 10}	Blank -PPM -PRM	Blank -SP ^{Note 6} -SR ^{Note 6} -SA ^{Note 6}	DC24V
F10 BPP (for block-off plate) ^{Note 4}										

Notes: 6. Port isolators can be installed only when piping blocks are mounted on both sides. In addition, only 1 port isolator can be mounted in 1 manifold for **-SA**, or 1 each port isolator for **-SP** and **-SR** for a total of 2 locations. When shipping, the designated port isolators are mounted between the designated station and the station to its immediate left (the next smaller stn. No.).

7. Cannot be mounted on the external pilot manifold.

8. Cannot be mounted on the internal pilot manifold.

9. Not available in external pilot type.

10. Not available with the individual exhaust spacer.

11. The 3-port specifications are only available in the valve specification **T0**, **T1**, and **T2**.

12. Can be selected only when the manifold type is T.

13. Can be selected only when the manifold type is TH.

Order codes for F10 Series Split Manifold with I/O Terminal

■ Quick Reference Chart of Maximum Number of Manifold Valves for Different Wiring Specifications

		Maximum number of valves	
		Wiring connection specification	
Wiring specifications	Maximum control points	Packed wiring (blank)	Double wiring (-W)
-K3 : EtherCAT (32 outputs) supported	32 points	Varies depending on the number of single solenoids, double solenoids, and block off plates that are mounted. Specify a number of units so that the number of solenoids being controlled does not exceed the maximum number of control units. -K3 and -M3 have a maximum of 20 connected units.	16 units
-M3 : EtherNet/IP (32 outputs) supported	32 points		16 units

* To determine the maximum number of I/O modules, see [page 7](#).

Order codes for F10 Series Easy Assembly Manifold with I/O Terminal

Manifold output specification

With dual use fitting blocks (base piping type)



With selectable fittings (base piping type)



Outlet port fitting F10: φ4, φ6

Outlet port should be selected in accordance with the manifold fitting specification.

With female thread blocks (base piping type)

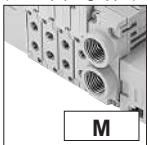

Outlet port female thread F10: M5 x 0.8

With plates (direct piping type)



Valve size

F10M 10 mm [0.394 in.] width

Pilot specification

Blank

Internal pilot manifold

G

External pilot manifold

Piping block specification (air supply and exhaust)

Fitting block

- JR: Dual use fitting, right-side mounting
- JL: Dual use fitting, left-side mounting
- JD: Dual use fitting, both-side mounting
- Fitting size (1(P), 3, 5(R) ports), φ6, φ8

Female thread block

- MR: Female thread, right-side mounting
- ML: Female thread, left-side mounting
- MD: Female thread, both-side mounting
- Female thread size (1(P), 3, 5(R) ports), Rc1/8

Female thread block

- MRH: Female thread, right-side mounting^{Note13}
- MLH: Female thread, left-side mounting^{Note13}
- MDH: Female thread, both-side mounting^{Note13}
- Female thread size (1(P), 3, 5(R) ports), NPT1/8

Single use fitting block

- J5R: Single use fitting, right-side mounting
- J5L: Single use fitting, left-side mounting
- J5D: Single use fitting, both-side mounting
- Fitting size (1(P), 3, 5(R) ports), φ6
- J6R: Single use fitting, right-side mounting
- J6L: Single use fitting, left-side mounting
- J6D: Single use fitting, both-side mounting
- Fitting size (1(P), 3, 5(R) ports), φ8

Intermediate piping block

- JT: Dual use fitting, both-side mounting, intermediate piping block φ6, φ8
- J5T: Single use fitting, both-side mounting, intermediate piping block φ6
- J6T: Single use fitting, both-side mounting, intermediate piping block φ8
- MT: Female thread, both-side mounting, intermediate piping block Rc1/8
- MTH: Female thread, both-side mounting, intermediate piping block NPT1/8^{Note13}

Wiring and communication specifications

K3: For EtherCAT (32 outputs) Input/output module supported

M3: EtherNet/IP (32 outputs) Input/output module supported

Module number specifications

Blank: No I/O modules (Only communication modules)

1 to 8: Number of I/O modules mounted 8 max.

Caution

When entering the order codes for input/output modules, indicate the input/output modules after indicating the mounted valves.

For details of how to indicate input/output modules, see Module (mod.1, etc.) in I/O Terminal Order Codes on page 7.

Mounting specification

Blank

Direct mount

-DN

With DIN brackets (without rails)

-DR

With DIN brackets, with rails
Note: For details of rails to be assembled and shipped, see page 29.

Wiring connection specification

Blank

Packed wiring:
Wiring is made in accordance with the mounted valve specifications.

-W

Double wiring:
Wiring is always for the double solenoid, regardless of the specifications of the mounted valve.

Valve size

F10 Standard type

F10L Low-current type

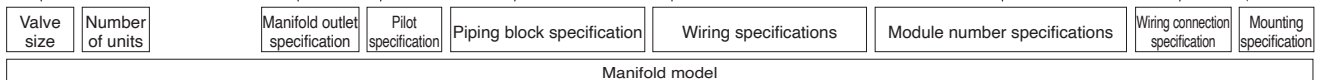

		Manifold model										
Base piping type	F10M	2 · · · Note 1	XT (※Rc)	J M	Blank G	-JR	-J5R	-JT	-K3	Blank -1~8	Blank -W	Blank -DN -DR
						-JL	-J5L	-J5T				
Base piping type selectable fitting	F10M	2 · · · Note 1	XT (※Rc) XTH (※NPT) Only L or Blank is available in the inch female thread specification and the manifold outlet specification.	L	Blank G	-JR	-MLH ^{Note12}	-J6D	-K3	Blank -1~8	Blank -W	Blank -DN -DR
						-JL	-MDH ^{Note12}	-JT				
Direct piping type	F10M	2 · · · Note 1	Blank	Blank G	Blank G	-JR	-MLH ^{Note12}	-J6D	-K3	Blank -1~8	Blank -W	Blank -DN -DR
						-JL	-MDH ^{Note12}	-JT				
						-JD	-J5R	-J5T				
						-MR	-J5L	-J6T				
						-ML	-J5D	-MT				
						-MD	-J6R	-MTH ^{Note12}				
						-MRH ^{Note12}	-J6L					

Notes: 1. For maximum number of units, see page 15 Quick Reference Chart of Maximum Number of Manifold Valves for Different Wiring Specifications.
 2. Valve mounting location is from the left, with the solenoid on top, and the 4(A), 2(B) port side in front.
 3. When selecting J, M, or L (base piping type) for the manifold outlet specifications, always enter -A1 (with plate) for the valve outlet type.
 4. For the wiring connection specification for block off plate, you can select single and double with the block off plate wiring connection specification, apart from the manifold (valve) wiring connection specification.
 5. When the valve specification is T1 or T2, the manual override lever is placed only on the A side.

Valve specification

- T0:** 2-position, for single solenoid only
- T1:** 2-position, single solenoid specification
- T2:** 2-position, double solenoid specification
- T3:** 3-position, closed center
- T4:** 3-position, exhaust center
- T5:** 3-position, pressure center
- TA:** Tandem 3-port (NC and NC)^{Note 9}
- TB:** Tandem 3-port (NO and NO)^{Note 9}
- TC:** Tandem 3-port (NC and NO)^{Note 9}

Operation type

Blank

Internal pilot type^{Note 7}

G

External pilot type^{Note 8}

(for positive pressure)

* No vacuum valve can be mounted.

Manual override

Manual override button



Manual override lever^{Note 5}

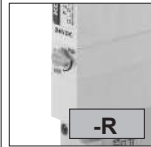

Valve outlet type

-A1 With plate^{Note 3}
(base piping type)

5-port specification

-FJ With dual use fitting block (direct piping type) **F10:** φ4, φ6

-FJ5 With single use fitting block (direct piping type) **F10:** φ4

-FJ6 With single use fitting block (direct piping type) **F10:** φ6

-FM With female thread blocks (direct piping type) **F10:** M5 x 0.8

-FMH With female thread block^{Note 13} (direct piping type) **F10:** 10-32UNF

3-port specification

-FJ5A With single use fitting block, normally closed (NC) (direct piping type) **F10:** φ4

-FJ5B With single use fitting block, normally open (NO) (direct piping type) **F10:** φ4

-FJ6A With single use fitting block, normally closed (NC) (direct piping type) **F10:** φ6

-FJ6B With single use fitting block, normally open (NO) (direct piping type) **F10:** φ6

-FMA With female thread block, normally closed (NC) (direct piping type) **F10:** M5 x 0.8

-FMAH With female thread block, normally closed (NC)^{Note 13} (direct piping type) **F10:** 10-32UNF

-FMB With female thread block, normally open (NO) (direct piping type) **F10:** M5 x 0.8

-FMBH With female thread block, normally open (NO)^{Note 13} (direct piping type) **F10:** 10-32UNF

The 3-port specifications are only available in the valve specification **T0**, **T1**, and **T2**.

Manifold fitting specification

5-port specification

-J5 With single use fitting block (base piping type) **F10:** φ4

-J6 With single use fitting block (base piping type) **F10:** φ6

-M With female thread blocks (base piping type) **F10:** M5 x 0.8

-MH With female thread block^{Note 13} (base piping type) **F10:** 10-32UNF

3-port specification

-J5A With single use fitting block, normally closed (NC) (base piping type) **F10:** φ4

-J5B With single use fitting block, normally open (NO) (base piping type) **F10:** φ4

-J6A With single use fitting block, normally closed (NC) (base piping type) **F10:** φ6

-J6B With single use fitting block, normally open (NO) (base piping type) **F10:** φ6

-MA With female thread block, normally closed (NC) (base piping type) **F10:** M5 x 0.8

-MAH With female thread block, normally closed (NC)^{Note 13} (base piping type) **F10:** 10-32UNF

-MB With female thread block, normally open (NO) (base piping type) **F10:** M5 x 0.8

-MBH With female thread block, normally open (NO)^{Note 13} (base piping type) **F10:** 10-32UNF

The 3-port specifications are only available in the valve specification **T0**, **T1**, and **T2**.

Back pressure prevention valve

Blank

No back pressure prevention valve

-E2

With back pressure prevention valve^{Note 10}

Individual air supply and exhaust spacer

Blank: No spacer

-XPPM: Individual air supply spacer (with M5 female thread for F10)

-XPRM: Individual exhaust spacer (with M5 female thread for F10)

Port isolator

Blank: No port isolator

-XSP: For 1(P) port^{Note 6}

-XSR: For 3(R2), 5(R1) ports^{Note 6}

-XSA: For 1(P), 3(R2), 5(R1) ports^{Note 6}

Block off plate wiring specification

Blank: Double wiring

-S: Single wiring

Station	Valve size	Valve specification	Operation type	Manual override	Valve outlet type	Manifold fitting specification	Back pressure prevention valve	Individual air supply and exhaust spacer	Port isolator	Block off plate wiring specification	Voltage
Mounting valve model											
stn. 1 : : stn. □ Note 2	F10 F10L	T0 T3 TA ^{Note 9} T1 T4 TB ^{Note 9} T2 T5 TC ^{Note 9}	Blank ^{Note 7} G ^{Note 8}	Blank -R ^{Note 5}	-A1 ^{Note 3}		Blank -E2 ^{Note 10}	Blank -XPPM -XPRM	Blank -XSP ^{Note 6} -XSR ^{Note 6} -XSA ^{Note 6}	DC24V	
	F10	XBPP (for block-off plate) ^{Note 4}								Blank -S	
If selecting an intermediate piping block, see page 19 to enter information.											
stn. 1 : : stn. □ Note 2	F10 F10L	T0 T3 TA ^{Note 9} T1 T4 TB ^{Note 9} T2 T5 TC ^{Note 9}	Blank ^{Note 7} G ^{Note 8}	Blank -R ^{Note 5}	-A1 ^{Note 3}	-J5 ^{Note 11} -J6 ^{Note 11} -M ^{Note 11} -MH ^{Note 12} -J5A ^{Note 11} -J5B ^{Note 11}	-J6A ^{Note 11} -J6B ^{Note 11} -MA ^{Note 11} -MAH ^{Note 12} -MB ^{Note 11} -MBH ^{Note 12}	Blank -XPPM -XPRM	Blank -XSP ^{Note 6} -XSR ^{Note 6} -XSA ^{Note 6}	DC24V	
	F10	XBPP (for block-off plate) ^{Note 4}								Blank -S	
If selecting an intermediate piping block, see page 19 to enter information.											
stn. 1 : : stn. □ Note 2	F10 F10L	T0 T3 TA ^{Note 9} T1 T4 TB ^{Note 9} T2 T5 TC ^{Note 9}	Blank ^{Note 7} G ^{Note 8}	Blank -R ^{Note 5}	-A1 ^{Note 3}	-FJ ^{Note 11} -FJ5 ^{Note 11} -FJ6 ^{Note 11} -FM ^{Note 11} -FMH ^{Note 12} -FJ5A ^{Note 11} -FJ5B ^{Note 11}	-FJ6A ^{Note 11} -FJ6B ^{Note 11} -FMA ^{Note 11} -FMAH ^{Note 12} -FMB ^{Note 11} -FMBH ^{Note 12}	Blank -XPPM -XPRM	Blank -XSP ^{Note 6} -XSR ^{Note 6} -XSA ^{Note 6}	DC24V	
	F10	XBPP (for block-off plate) ^{Note 4}								Blank -S	
If selecting an intermediate piping block, see page 19 to enter information.											

Notes: 6. Port isolators can be installed only when piping blocks are mounted on both sides. In addition, only 1 port isolator can be mounted in 1 manifold for -XSA, or 1 each port isolator for -XSP and -XSR for a total of 2 locations. When shipping, the designated port isolators are mounted between the designated station and the station to its immediate left (the next smaller stn. No.).
7. Cannot be mounted on the external pilot manifold.

8. Cannot be mounted on the internal pilot manifold.
9. Not available in external pilot type.
10. Not available with the individual exhaust spacer.
11. The 3-port specifications are only available in the valve specification **T0**, **T1**, and **T2**.
12. Can be selected only when the manifold type is **XTH**.

Order codes for F10 Series Easy Assembly Manifold with I/O Terminal

Intermediate piping block

(When mounting an intermediate piping block to the manifold, complete the following type and specify the station specified on [page 18](#).)

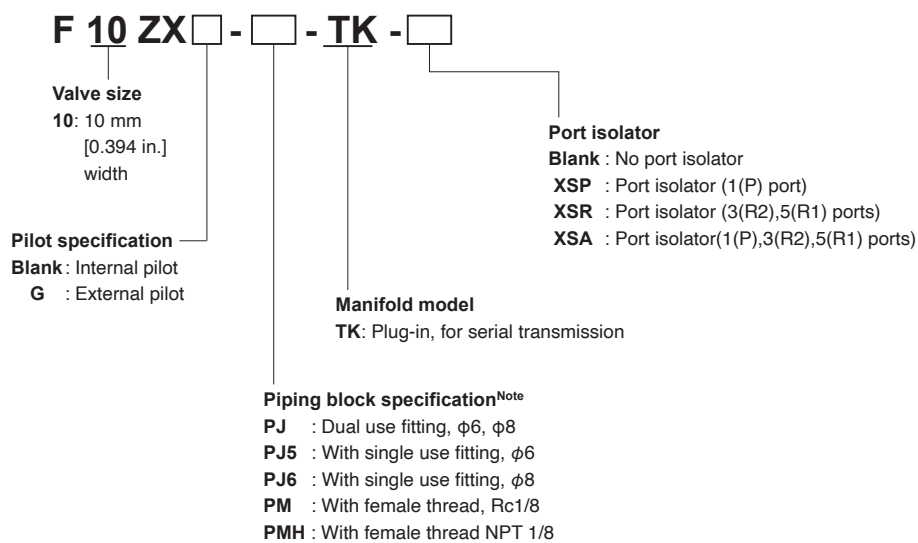

Note: See the following table for combinations of intermediate piping block port specifications and manifold piping block specifications.

Manifold piping specification	Intermediate piping block
JT	PJ
J5T	PJ5
J6T	PJ6
MT	PM
MTH	PMH

Manifold output specification

With dual use fitting blocks (base piping type)



With selectable fittings (base piping type)



Outlet port fitting F15: φ6, φ8

Outlet port should be selected in accordance with the manifold fitting specification.

With female thread blocks (base piping type)

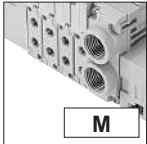

Outlet port female thread F15: Rc1/8

With plates (direct piping type)

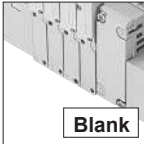

Blank

Valve size

F15M 15 mm [0.591 in.] width

Pilot specification

Blank

Internal pilot manifold

G

External pilot manifold

Piping block specification (air supply and exhaust)

Dual size fitting block

- JR : Dual use fitting, right-side mounting^{Note12}
- JL : Dual use fitting, left-side mounting^{Note12}
- JD : Dual use fitting, both-side mounting^{Note12}
Fitting size (1(P), 3, 5(R) ports), φ 8, φ 10

Female thread block

- MR : Female thread, right-side mounting^{Note12}
- ML : Female thread, left-side mounting^{Note12}
- MD : Female thread, both-side mounting^{Note12}
Female thread size (1(P), 3, 5(R) ports), Rc1/4

Female thread block

- MRH : Female thread, right-side mounting^{Note13}
- MLH : Female thread, left-side mounting^{Note13}
- MDH : Female thread, both-side mounting^{Note13}
Female thread size (1(P), 3, 5(R) ports), NPT1/4

Single use fitting block

- JR : Single use fitting, right-side mounting^{Note12}
- JL : Single use fitting, left-side mounting^{Note12}
- JD : Single use fitting, both-side mounting^{Note12}
Fitting size (1(P), 3, 5(R) ports), φ 8
- JR : Single use fitting, right-side mounting^{Note12}
- JL : Single use fitting, left-side mounting^{Note12}
- JD : Single use fitting, both-side mounting^{Note12}
Fitting size (1(P), 3, 5(R) ports), φ 10

Wiring and communication specifications

K3 : For EtherCAT (32 outputs) Input/output module supported

M3 : EtherNet/IP (32 outputs) Input/output module supported

Module number specifications

Blank : No I/O modules (Only communication modules)

1 to 8 : Number of I/O modules mounted 8 max.

Caution

When entering the order codes for input/output modules, indicate the input/output modules after indicating the mounted valves.

For details of how to indicate input/output modules, see Module (mod.1, etc.) in I/O Terminal Order Codes on page 7.

Valve size

F15 Standard type

F15L Low-current type

Wiring connection specification

Blank

Packed wiring: Wiring is made in accordance with the mounted valve specifications.

-W

Double wiring: Wiring is always for the double solenoid, regardless of the specifications of the mounted valve.

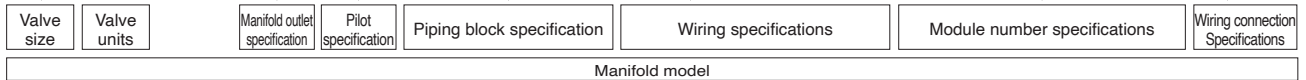

		Manifold model						
Base piping type	Manifold outlet specification	Pilot specification	Piping block specification	Wiring specifications	Module number specifications	Wiring connection Specifications	Valve size	
Base piping type	T (*Rc)	J M	Blank G	-JR -J5R -JL -J6R -JD -J5L -MR -J6L -ML -J5D -MD -J6D	-K3 -M3	Blank -1~8	Blank -W	
Base piping type selectable fitting	F15M 2 · · · □ ^{Note 1}	L	Blank G	-JR ^{Note12} -MDH ^{Note13} -JL ^{Note12} -J5R ^{Note12} -JD ^{Note12} -J6R ^{Note12} -MR ^{Note12} -J5L ^{Note12} -ML ^{Note12} -J6L ^{Note12} -MD ^{Note12} -J5D ^{Note12} -MRH ^{Note13} -J6D ^{Note12} -MLH ^{Note13}	-K3 -M3	Blank -1~8	Blank -W	
Direct piping type	TH (*NPT)	Blank	Blank G	-JR ^{Note12} -MDH ^{Note13} -JL ^{Note12} -J5R ^{Note12} -JD ^{Note12} -J6R ^{Note12} -MR ^{Note12} -J5L ^{Note12} -ML ^{Note12} -J6L ^{Note12} -MD ^{Note12} -J5D ^{Note12} -MRH ^{Note13} -J6D ^{Note12} -MLH ^{Note13}	-K3 -M3	Blank -1~8	Blank -W	

- Notes: 1. For maximum number of units, see page 15 Quick Reference Chart of Maximum Number of Manifold Valves for Different Wiring Specifications.
 2. Valve mounting location is from the left, with the solenoid on top, and the 4(A), 2(B) port side in front.
 3. When selecting J, M, or L (base piping type) for the manifold outlet specifications, always enter -A1 (with plate) for the valve outlet type.
 4. The block-off plate wiring is always double wiring (allocated 2 control pins at 1 str.), regardless of the wiring connection specification. The block-off plate wiring can be made as wiring for a single solenoid. Add -1W to the end of the block-off plate order code in the case. For details, contact a Koganei sales office.
 5. When the valve specification is T1 or T2, the manual override lever is placed only on the A side.

Valve specification

- T0: 2-position, for single solenoid only
- T1: 2-position, single solenoid specification
- T2: 2-position, double solenoid specification
- T3: 3-position, closed center
- T4: 3-position, exhaust center
- T5: 3-position, pressure center
- TA: Tandem 3-port (NC and NC)^{Note 9}
- TB: Tandem 3-port (NO and NO)^{Note 9}
- TC: Tandem 3-port (NC and NO)^{Note 9}

Operation type

Blank

Internal pilot type^{Note 7}

G

External pilot type^{Note 8}
(for positive pressure)

* No vacuum valve can be mounted.

Manual override

Manual override button



Manual override lever^{Note 5}



Valve outlet type

-A1 With plate^{Note 3}
(base piping type)

5-port specification

-FJ With dual use fitting block
(direct piping type) F15: φ6, φ8

-FJ5 With single use fitting block
(direct piping type) F15: φ6

-FJ6 With single use fitting block
(direct piping type) F15: φ8

-FM With female thread block
(direct piping type) F15: Rc1/8

-FMH With female thread block^{Note 13}
(direct piping type) F10: NPT1/8

3-port specification

-FJ5A With single use fitting block,
normally closed (NC)
(direct piping type) F15: φ6

-FJ5B With single use fitting block,
normally open (NO)
(direct piping type) F15: φ6

-FJ6A With single use fitting block,
normally closed (NC)
(direct piping type) F15: φ8

-FJ6B With single use fitting block,
normally open (NO)
(direct piping type) F15: φ8

-FMA With female thread block,
normally closed (NC)
(direct piping type) F15: Rc1/8

-FMAH With female thread block,
normally closed (NC)^{Note 12}
(direct piping type) F15: NPT1/8

-FMB With female thread block,
normally open (NO)
(direct piping type) F15: Rc1/8

-FMBH With female thread block,
normally open (NO)^{Note 13}
(direct piping type) F15: NPT1/8

The 3-port specifications are only available in the valve specification T0, T1, and T2.

Manifold fitting specification

5-port specification

-J5 With single use fitting block
(base piping type) F15: φ6

-J6 With single use fitting block
(base piping type) F15: φ8

-M With female thread block
(base piping type) F15: Rc1/8

-MH With female thread block^{Note 11}
(base piping type) F15: NPT1/8

3-port specification

-J5A With single use fitting block, normally closed (NC)
(base piping type) F15: φ6

-J5B With single use fitting block, normally open (NO)
(base piping type) F15: φ6

-J6A With single use fitting block, normally closed (NC)
(base piping type) F15: φ8

-J6B With single use fitting block, normally open (NO)
(base piping type) F15: φ8

-MA With female thread block, normally closed (NC)
(base piping type) F15: Rc1/8

-MAH With female thread block, normally closed (NC)^{Note 13}
(base piping type) F15: NPT1/8

-MB With female thread block, normally open (NO)
(base piping type) F15: Rc1/8

-MBH With female thread block, normally open (NO)^{Note 13}
(base piping type) F15: NPT1/8

NOTE The 3-port specifications are only available in the valve specification T0, T1, and T2.

Back pressure prevention valve

Blank

No back pressure prevention valve

-E2

With back pressure prevention valve^{Note 10}

Individual air supply and exhaust spacer

Blank: No spacer

-PP6: Individual air supply spacer
(with φ 6 fitting for F15)

-PP8: Individual air supply spacer
(with φ 8 fitting for F15)

-PR6: Individual exhaust spacer
(with φ 6 fitting for F15)

-PR8: Individual exhaust spacer
(with φ 8 fitting for F15)

Port isolator

Blank: No port isolator

-SP: For 1(P) port^{Note 6}

-SR: For 3(R2), 5(R1) ports^{Note 6}

-SA: For 1(P), 3(R2), 5(R1) ports^{Note 6}

Station	Valve size	Valve specification	Operation type	Manual override	Valve outlet type	Manifold fitting specification	Back pressure prevention valve	Individual air supply and exhaust spacer	Port isolator	Voltage
---------	------------	---------------------	----------------	-----------------	-------------------	--------------------------------	--------------------------------	--	---------------	---------

Mounting valve model

stn. 1 ⋮ stn. □ <small>Note 2</small>	F15	T0 T3 TA ^{Note 9} T1 T4 TB ^{Note 9} T2 T5 TC ^{Note 9}	Blank ^{Note 7} G ^{Note 8}	Blank -R ^{Note 5}	-A1 ^{Note 3}		Blank -E2 ^{Note 10}	Blank -PP6 -PR6 -PP8 -PR8	Blank -SP ^{Note 6} -SR ^{Note 6} -SA ^{Note 6}	DC24V
	F15	BPP (for block-off plate) ^{Note 4}								
stn. 1 ⋮ stn. □ <small>Note 2</small>	F15	T0 T3 TA ^{Note 9} T1 T4 TB ^{Note 9} T2 T5 TC ^{Note 9}	Blank ^{Note 7} G ^{Note 8}	Blank -R ^{Note 5}	-A1 ^{Note 3}	-J5 ^{Note 12} -J6A ^{Note 12} -J6 ^{Note 12} -J6B ^{Note 12} -M ^{Note 12} -MA ^{Note 12} -MH ^{Note 11} -MAH ^{Note 13} -J5A ^{Note 12} -MB ^{Note 12} -J5B ^{Note 12} -MBH ^{Note 13}	Blank -E2 ^{Note 10}	Blank -PP6 -PR6 -PP8 -PR8	Blank -SP ^{Note 6} -SR ^{Note 6} -SA ^{Note 6}	DC24V
	F15	BPP (for block-off plate) ^{Note 4}								
stn. 1 ⋮ stn. □ <small>Note 2</small>	F15	T0 T3 TA ^{Note 9} T1 T4 TB ^{Note 9} T2 T5 TC ^{Note 9}	Blank ^{Note 7} G ^{Note 8}	Blank -R ^{Note 5}	-A1 ^{Note 3}	-FJ ^{Note 12} -FJ6A ^{Note 12} -FJ5 ^{Note 12} -FJ6B ^{Note 12} -FJ6 ^{Note 12} -FMA ^{Note 12} -FM ^{Note 12} -FMAH ^{Note 13} -FMH ^{Note 13} -FMB ^{Note 12} -FMH ^{Note 13} -FMBH ^{Note 11} -FJ5A ^{Note 12} -FJ5B ^{Note 12}	Blank -E2 ^{Note 10}	Blank -PP6 -PR6 -PP8 -PR8	Blank -SP ^{Note 6} -SR ^{Note 6} -SA ^{Note 6}	DC24V
	F15	BPP (for block-off plate) ^{Note 4}								

Notes: 6. Port isolators can be installed only when piping blocks are mounted on both sides. In addition, only 1 port isolator can be mounted in 1 manifold for -SA, or 1 each port isolator for -SP and -SR for a total of 2 locations. When shipping, the designated port isolators are mounted between the designated station and the station to its immediate left (the next smaller stn. No.).
7. Cannot be mounted on the external pilot manifold.

8. Cannot be mounted on the internal pilot manifold.
9. Not available in external pilot type.
10. Not available with the individual exhaust spacer.
11. The 3-port specifications are only available in the valve specification T0, T1, and T2.
12. Can be selected only when the manifold type is T.
13. Can be selected only when the manifold type is TH.

Order codes for F15 Series Split Manifold with I/O Terminal

■ Quick Reference Chart of Maximum Number of Manifold Valves for Different Wiring Specifications

		Maximum number of valves	
		Wiring connection specification	
Wiring specifications	Maximum control points	Packed wiring (blank)	Double wiring (-W)
-K3: EtherCAT (32 outputs) supported	32 points	Varies depending on the number of single solenoids, double solenoids, and block off plates that are mounted. Specify a number of units so that the number of solenoids being controlled does not exceed the maximum number of control units. -K3 and -M3 have a maximum of 20 connected units.	16 units
-M3: EtherNet/IP (32 outputs) supported	32 points		16 units

* To determine the maximum number of I/O modules, see [page 7](#).

Manifold output specification

With dual use fitting blocks (base piping type) **J**

With selectable fittings (base piping type) **L**

With female thread blocks (base piping type) **M**

With plates (direct piping type) **Blank**

Outlet port fitting F15: φ6, φ8

Outlet port should be selected in accordance with the manifold fitting specification.

Outlet port female thread F15: Rc1/8

Valve size
F15M 15 mm [0.591 in.] width

Pilot specification

Blank
Internal pilot manifold

G
External pilot manifold

Piping block specification (air supply and exhaust)

Fitting block
-JR: Dual use fitting, right-side mounting
-JL: Dual use fitting, left-side mounting
-JD: Dual use fitting, both-side mounting
 Fitting size (1(P), 3, 5(R) ports), φ6, φ8

Female thread block
-MR: Female thread, right-side mounting
-ML: Female thread, left-side mounting
-MD: Female thread, both-side mounting
 Female thread size (1(P), 3, 5(R) ports), Rc1/8

Female thread block
-MRH: Female thread, right-side mounting^{Note13}
-MLH: Female thread, left-side mounting^{Note13}
-MDH: Female thread, both-side mounting^{Note13}
 Female thread size (1(P), 3, 5(R) ports), NPT1/8

Single use fitting block
-J5R: Single use fitting, right-side mounting
-J5L: Single use fitting, left-side mounting
-J5D: Single use fitting, both-side mounting
 Fitting size (1(P), 3, 5(R) ports), φ6

-J6R: Single use fitting, right-side mounting
-J6L: Single use fitting, left-side mounting
-J6D: Single use fitting, both-side mounting
 Fitting size (1(P), 3, 5(R) ports), φ8

Intermediate piping block
-JT: Dual use fitting, both-side mounting, intermediate piping block φ6, φ8
-J5T: Single use fitting, both-side mounting, intermediate piping block φ6
-J6T: Single use fitting, both-side mounting, intermediate piping block φ8
-MT: Female thread, both-side mounting, intermediate piping block Rc1/8
-MTH: Female thread, both-side mounting, intermediate piping block NPT1/8^{Note13}

Wiring and communication specifications

K3: For EtherCAT (32 outputs) Input/output module supported

M3: EtherNet/IP (32 outputs) Input/output module supported

Module number specifications

Blank: No I/O modules (Only communication modules)

1 to 8: Number of I/O modules mounted 8 max.

Caution
When entering the order codes for input/output modules, indicate the input/output modules after indicating the mounted valves.
For details of how to indicate input/output modules, see Module (mod.1, etc.) in I/O Terminal Order Codes on page 7.

Wiring connection specification

Blank
Packed wiring: Wiring is made in accordance with the mounted valve specifications.

-W
Double wiring: Wiring is always for the double solenoid, regardless of the specifications of the mounted valve.

Mounting specification

Blank
Direct mount

-DN
With DIN brackets (without rails)

-DR
With DIN brackets, with rails
Note: For details of rails to be assembled and shipped, see page 31.

Valve size

F15 Standard type

F15L Low-current type

Valve size

Number of units

Manifold outlet specification

Pilot specification

Piping block specification

Wiring specifications

Module number specifications

Wiring connection specification

Mounting specification

Manifold model									
Base piping type	Manifold outlet specification	Pilot specification	Piping block specification	Wiring specifications	Module number specifications	Wiring connection specification	Mounting specification		
Base piping type	XT (※Rc)	J M	Blank G	-JR -J5R -JT -JL -J5L -J5T -JD -J5D -J6T -MR -J6R -MT -ML -J6L -MD -J6D	-K3 -M3	Blank -1~8	Blank -W	Blank -DN -DR	
Base piping type selectable fitting	F15M	2 · · □ Note 1	XT (※Rc) XTH (※NPT) Only L or Blank is available in the inch female thread specification and the manifold outlet specification.	L G	JR -MLH ^{Note12} -J6D JL -MDH ^{Note12} -JT JD -J5R -J5T MR -J5L -J6T ML -J5D -MT MD -J6R -MTH ^{Note12} MRH ^{Note12} -J6L	-K3 -M3	Blank -1~8	Blank -DN -DR	
Direct piping type			Blank G	JR -MLH ^{Note12} -J6D JL -MDH ^{Note12} -JT JD -J5R -J5T MR -J5L -J6T ML -J5D -MT MD -J6R -MTH ^{Note12} MRH ^{Note12} -J6L	-K3 -M3	Blank -1~8	Blank -W	Blank -DN -DR	

Notes: 1. For maximum number of units, see page 15 Quick Reference Chart of Maximum Number of Manifold Valves for Different Wiring Specifications.
 2. Valve mounting location is from the left, with the solenoid on top, and the 4(A), 2(B) port side in front.
 3. When selecting J, M, or L (base piping type) for the manifold outlet specifications, always enter -A1 (with plate) for the valve outlet type.
 4. For the wiring connection specification for block off plate, you can select single and double with the block off plate wiring connection specification, apart from the manifold (valve) wiring connection specification.
 5. When the valve specification is T1 or T2, the manual override lever is placed only on the A side.

Valve specification

- T0:** 2-position, for single solenoid only
- T1:** 2-position, single solenoid specification
- T2:** 2-position, double solenoid specification
- T3:** 3-position, closed center
- T4:** 3-position, exhaust center
- T5:** 3-position, pressure center
- TA:** Tandem 3-port (NC and NC)^{Note 9}
- TB:** Tandem 3-port (NO and NO)^{Note 9}
- TC:** Tandem 3-port (NC and NO)^{Note 9}

Operation type

Blank

Internal pilot type^{Note 7}

G

External pilot type^{Note 8}

(for positive pressure)

* No vacuum valve can be mounted.

Manual override

Manual override button



Manual override lever^{Note 5}

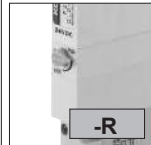

Valve outlet type

-A1 With plate^{Note 3}
(base piping type)

5-port specification

-FJ With dual use fitting block
(direct piping type) **F15:** φ6, φ8

-FJ5 With single use fitting block
(direct piping type) **F15:** φ6

-FJ6 With single use fitting block
(direct piping type) **F15:** φ8

-FM With female thread blocks
(direct piping type) **F15:** Rc1/8

-FMH With female thread block^{Note 13}
(direct piping type) **F15:** NPT1/8

3-port specification

-FJ5A With single use fitting block, normally closed (NC)
(direct piping type) **F15:** φ6

-FJ5B With single use fitting block, normally open (NO)
(direct piping type) **F15:** φ6

-FJ6A With single use fitting block, normally closed (NC)
(direct piping type) **F15:** φ8

-FJ6B With single use fitting block, normally open (NO)
(direct piping type) **F15:** φ8

-FMA With female thread block, normally closed (NC)
(direct piping type) **F15:** Rc1/8

-FMAH With female thread block, normally closed
(NC)^{Note 13} (direct piping type) **F15:** NPT1/8

-FMB With female thread block, normally open (NO)
(direct piping type) **F15:** Rc1/8

-FMBH With female thread block, normally open
(NO)^{Note 13} (direct piping type) **F15:** NPT1/8

The 3-port specifications are only available in the valve specification **T0**, **T1**, and **T2**.

Manifold fitting specification

5-port specification

-J5 With single use fitting block
(base piping type) **F15:** φ6

-J6 With single use fitting block
(base piping type) **F15:** φ8

-M With female thread blocks
(base piping type) **F15:** Rc1/8

-MH With female thread block^{Note 13}
(base piping type) **F15:** NPT1/8

3-port specification

-J5A With single use fitting block, normally closed (NC)
(base piping type) **F15:** φ6

-J5B With single use fitting block, normally open (NO)
(base piping type) **F15:** φ6

-J6A With single use fitting block, normally closed (NC)
(base piping type) **F15:** φ8

-J6B With single use fitting block, normally open (NO)
(base piping type) **F15:** φ8

-MA With female thread block, normally closed (NC)
(base piping type) **F15:** Rc1/8

-MAH With female thread block, normally closed (NC)^{Note 13}
(base piping type) **F15:** NPT1/8

-MB With female thread block, normally open (NO)
(base piping type) **F15:** Rc1/8

-MBH With female thread block, normally open (NO)^{Note 13}
(base piping type) **F15:** NPT1/8

The 3-port specifications are only available in the valve specification **T0**, **T1**, and **T2**.

Back pressure prevention valve

Blank

No back pressure prevention valve

-E2

With back pressure prevention valve^{Note 10}

Individual air supply and exhaust spacer

Blank: No spacer

-PP6: Individual air supply spacer
(with φ 6 fitting for F15)

-PP8: Individual air supply spacer
(with φ 8 fitting for F15)

-PR6: Individual exhaust spacer
(with φ 6 fitting for F15)

-PR8: Individual exhaust spacer
(with φ 8 fitting for F15)

Port isolator

Blank: No port isolator

-XSP: For 1(P) port^{Note 6}

-XSR: For 3(R2), 5(R1) ports^{Note 6}

-XSA: For 1(P), 3(R2), 5(R1) ports^{Note 6}

Block off plate wiring specification

Blank: Double wiring

-S: Single wiring

Station	Valve size	Valve specification	Operation type	Manual override	Valve outlet type	Manifold fitting specification	Back pressure prevention valve	Individual air supply and exhaust spacer	Port isolator	Block off plate wiring specification	Voltage
stn. 1 : : stn. □ Note 2	F15 F15L	T0 T3 TA ^{Note 9} T1 T4 TB ^{Note 9} T2 T5 TC ^{Note 9}	Blank ^{Note 7} G ^{Note 8}	Blank -R ^{Note 5}	-A1 ^{Note 3}		Blank -E2 ^{Note 10}	Blank -XPP6 -XPR6 -XPP8 -XPR8	Blank -XSP ^{Note 6} -XSR ^{Note 6} -XSA ^{Note 6}	DC24V Blank -S	
<p>F15 XBPP (for block-off plate)^{Note 4}</p> <p>If selecting an intermediate piping block, see page 27 to enter information.</p>											
stn. 1 : : stn. □ Note 2	F15 F15L	T0 T3 TA ^{Note 9} T1 T4 TB ^{Note 9} T2 T5 TC ^{Note 9}	Blank ^{Note 7} G ^{Note 8}	Blank -R ^{Note 5}	-A1 ^{Note 3}	-J5 ^{Note 11} -J6A ^{Note 11} -J6 ^{Note 11} -J6B ^{Note 11} -M ^{Note 11} -MA ^{Note 11} -MH ^{Note 12} -MAH ^{Note 12} -J5A ^{Note 11} -MB ^{Note 11} -J5B ^{Note 11} -MBH ^{Note 12}	Blank -E2 ^{Note 10}	Blank -XPP6 -XPR6 -XPP8 -XPR8	Blank -XSP ^{Note 6} -XSR ^{Note 6} -XSA ^{Note 6}	DC24V Blank -S	
<p>F15 XBPP (for block-off plate)^{Note 4}</p> <p>If selecting an intermediate piping block, see page 27 to enter information.</p>											
stn. 1 : : stn. □ Note 2	F15 F15L	T0 T3 TA ^{Note 9} T1 T4 TB ^{Note 9} T2 T5 TC ^{Note 9}	Blank ^{Note 7} G ^{Note 8}	Blank -R ^{Note 5}	-FJ ^{Note 11} -FJ6A ^{Note 11} -FJ5 ^{Note 11} -FJ6B ^{Note 11} -FJ6 ^{Note 11} -FMA ^{Note 11} -FM ^{Note 11} -FMAH ^{Note 12} -FMH ^{Note 12} -FMB ^{Note 11} -FJ5A ^{Note 11} -FMBH ^{Note 12} -FJ5B ^{Note 11}		Blank -E2 ^{Note 10}	Blank -XPP6 -XPR6 -XPP8 -XPR8	Blank -XSP ^{Note 6} -XSR ^{Note 6} -XSA ^{Note 6}	DC24V Blank -S	
<p>F15 XBPP (for block-off plate)^{Note 4}</p> <p>If selecting an intermediate piping block, see page 27 to enter information.</p>											

Notes: 6. Port isolators can be installed only when piping blocks are mounted on both sides. In addition, only 1 port isolator can be mounted in 1 manifold for -XSA, or 1 each port isolator for -XSP and -XSR for a total of 2 locations. When shipping, the designated port isolators are mounted between the designated station and the station to its immediate left (the next smaller stn. No.).

7. Cannot be mounted on the external pilot manifold.

8. Cannot be mounted on the internal pilot manifold.

9. Not available in external pilot type.

10. Not available with the individual exhaust spacer.

11. The 3-port specifications are only available in the valve specification **T0**, **T1**, and **T2**.

12. Can be selected only when the manifold type is XTH.

Order codes for F15 Series Easy Assembly Manifold with I/O Terminal

Intermediate piping block

(When mounting an intermediate piping block to the manifold, complete the following type and specify the station specified on [page 26](#).)

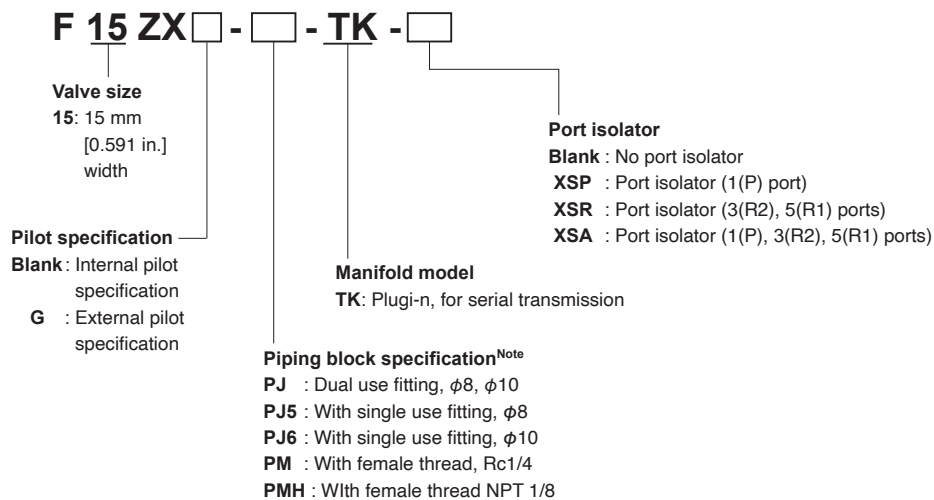

Note: See the following table for combinations of intermediate piping block port specifications and manifold piping block specifications.

Manifold piping specification	Intermediate piping block
JT	PJ
J5T	PJ5
J6T	PJ6
MT	PM
MTH	PMH

● I/O Terminal (EtherCAT communication)

YS8EK3 - [Number of I/O modules] - [Mounting specification]

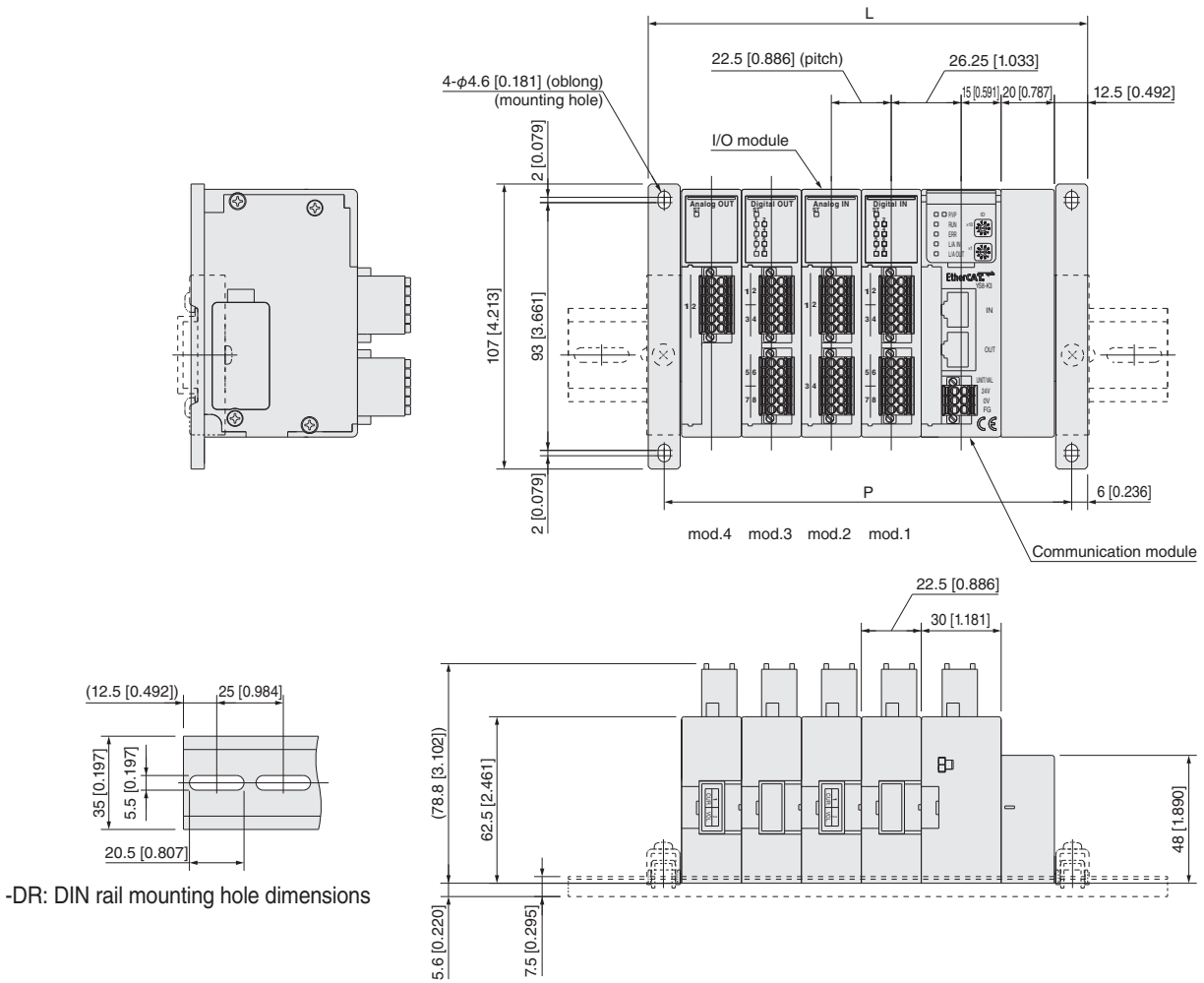

-DR: DIN rail mounting hole dimensions

Dimensions for each number of I/O modules

Number of mods	L	P	DIN rail
1	97.5 [3.839]	85.5 [3.366]	150 [5.906]
2	120.0 [4.724]	108.0 [4.252]	175 [6.890]
3	142.5 [5.610]	130.5 [5.138]	200 [7.874]
4	165.0 [6.496]	153.0 [6.024]	225 [8.858]
5	187.5 [7.382]	175.5 [6.909]	225 [8.858]
6	210.0 [8.268]	198.0 [7.795]	250 [9.843]
7	232.5 [9.154]	220.5 [8.681]	275 [10.827]
8	255.0 [10.039]	243.0 [9.567]	300 [11.811]

Examples of models in illustration

- YS8EK3-4
 mod.1 YS8-D8N
 mod.2 YS8-A4N
 mod.3 YS8-D8S
 mod.4 YS8-A2S

Note 1: The maximum number of units that can be connected is 8.

Dimensions (mm [in.])

● I/O Terminal (EtherNet/IP communication)

YS8EM3 - Number of I/O modules - Mounting specification

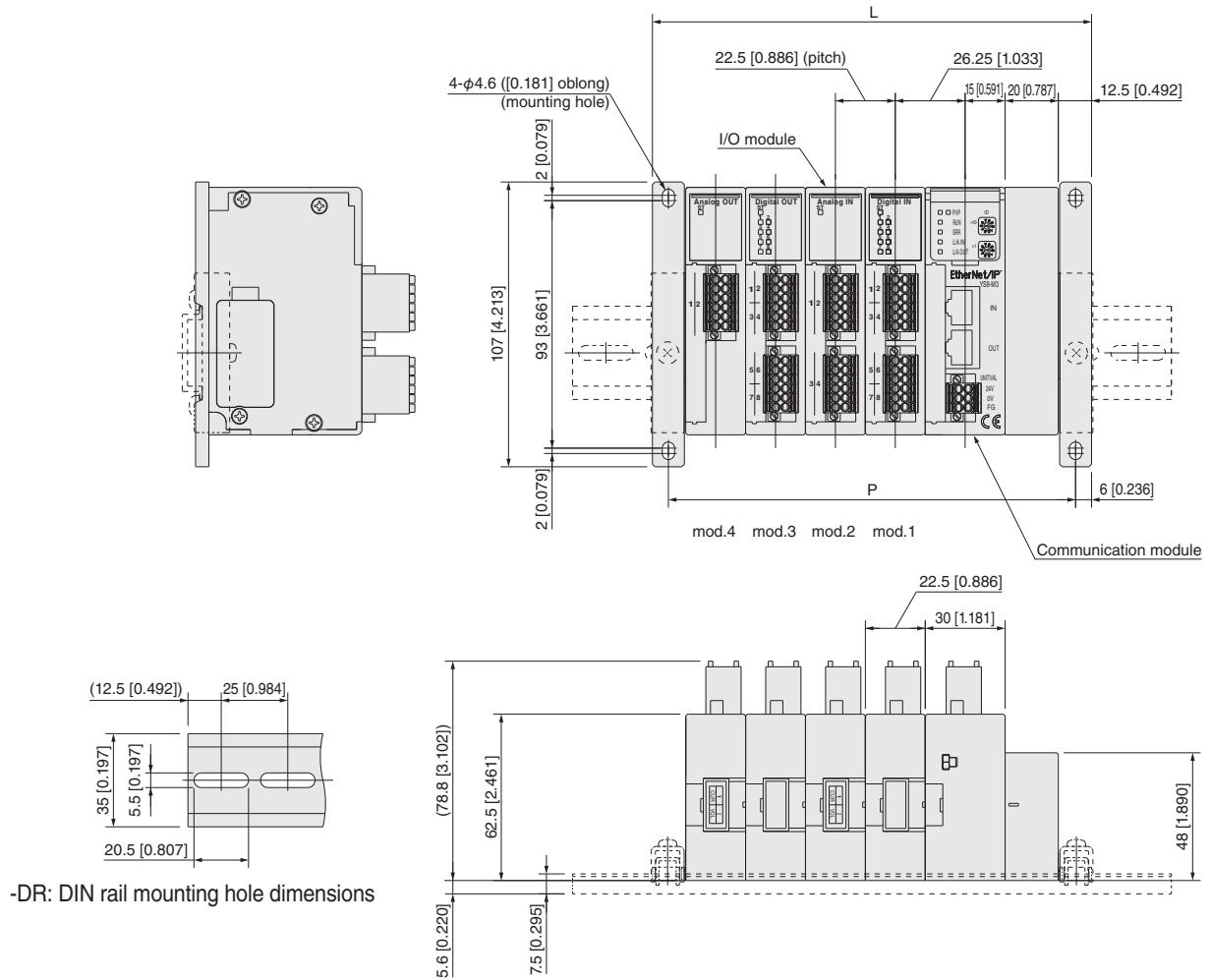

Dimensions for each number of I/O modules

Number of mods	L	P	DIN rail
1	97.5 [3.839]	85.5 [3.366]	150 [5.906]
2	120.0 [4.724]	108.0 [4.252]	175 [6.890]
3	142.5 [5.610]	130.5 [5.138]	200 [7.874]
4	165.0 [6.496]	153.0 [6.024]	225 [8.858]
5	187.5 [7.382]	175.5 [6.909]	225 [8.858]
6	210.0 [8.268]	198.0 [7.795]	250 [9.843]
7	232.5 [9.154]	220.5 [8.681]	275 [10.827]
8	255.0 [10.039]	243.0 [9.567]	300 [11.811]

Examples of models in illustration

- YS8EM3-4
- mod.1 YS8-D8N
- mod.2 YS8-A4N
- mod.3 YS8-D8S
- mod.4 YS8-A2S

Note 1: The maximum number of units that can be connected is 8.

Dimensions (mm)

F10 Series Split Manifold with I/O Terminal

F10M Valve units **T** **J** **M** Pilot specification (base piping type)

Manifold outlet port with dual use fitting block
(EtherCAT, EtherNet/IP) * The figures show EtherCAT.

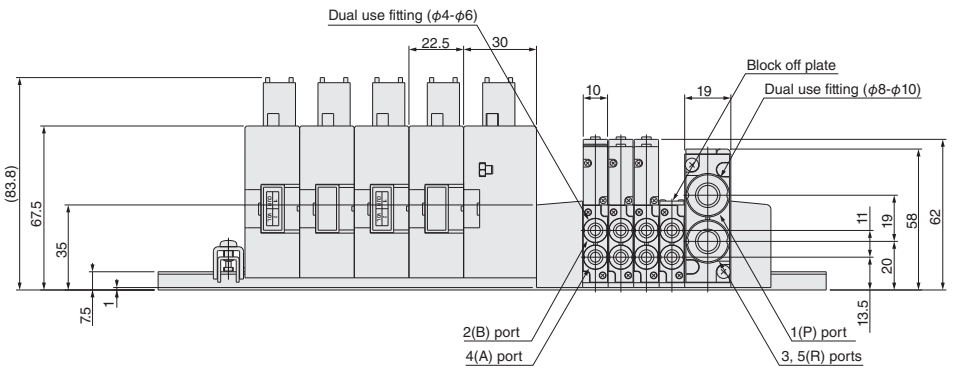
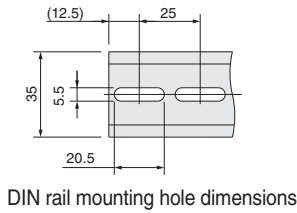
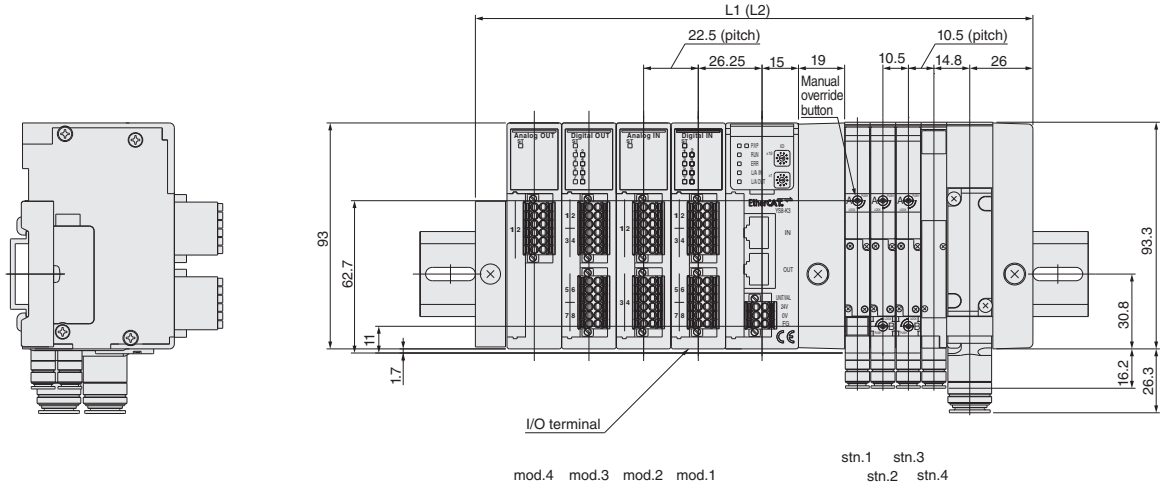

Examples of models in illustration

F10M4TJ-JR-K3-4-W

- | | | | |
|-------|----------------|-------|---------|
| stn.1 | F10T1-A1/DC24V | mod.1 | YS8-D8N |
| stn.2 | F10T2-A1/DC24V | mod.2 | YS8-A4N |
| stn.3 | F10T3-A1/DC24V | mod.3 | YS8-D8S |
| stn.4 | F10XBPP | mod.4 | YS8-A2S |

Number of mods	L1 For one piping block																L2 For two piping blocks																			
	0		1		2		3		4		5		6		7		8		0		1		2		3		4		5		6		7		8	
Dimension location	L1	DIN	L1	DIN	L1	DIN	L1	DIN	L1	DIN	L1	DIN	L1	DIN	L1	DIN	L2	DIN	L2	DIN	L2	DIN	L2	DIN	L2	DIN	L2	DIN	L2	DIN	L2	DIN				
2	105.5	175	141	200	163.5	200	186	225	208.5	250	231	275	253.5	300	276	325	298.5	350	124.5	175	160	200	182.5	225	205	250	227.5	275	250	300	272.5	325	295	350	317.5	375
3	116	175	151.5	200	174	225	196.5	250	219	275	241.5	300	264	300	286.5	325	309	350	135	200	170.5	225	193	250	215.5	275	238	275	260.5	300	283	325	305.5	350	328	375
4	126.5	175	162	200	184.5	225	207	250	229.5	275	252	300	274.5	325	297	350	319.5	375	145.5	200	181	225	203.5	250	226	275	248.5	300	271	325	293.5	350	316	375	338.5	375
5	137	200	172.5	225	195	250	217.5	275	240	300	262.5	300	285	325	307.5	350	330	375	156	225	191.5	250	214	250	236.5	275	259	300	281.5	325	304	350	326.5	375	349	400
6	147.5	200	183	225	205.5	250	228	275	250.5	300	273	325	295.5	350	318	375	340.5	400	166.5	225	202	250	224.5	275	247	300	269.5	325	292	350	314.5	350	337	375	359.5	400
7	158	225	193.5	250	216	275	238.5	275	261	300	283.5	325	306	350	328.5	375	351	400	177	250	212.5	250	235	275	257.5	300	280	325	302.5	350	325	375	347.5	400	370	425
8	168.5	225	204	250	226.5	275	249	300	271.5	325	294	350	316.5	375	339	375	361.5	400	187.5	250	223	275	245.5	300	268	325	290.5	350	313	350	335.5	375	358	400	380.5	425
9	179	250	214.5	250	237	275	259.5	300	282	325	304.5	350	327	375	349.5	400	372	425	198	250	233.5	275	256	300	278.5	325	301	350	323.5	375	346	400	368.5	425	391	450
10	189.5	250	225	275	247.5	300	270	325	292.5	350	315	375	337.5	375	360	400	382.5	425	208.5	275	244	300	266.5	325	289	325	311.5	350	334	375	356.5	400	379	425	401.5	450
11	200	250	235.5	275	258	300	280.5	325	303	350	325.5	375	348	400	370.5	425	393	450	219	275	254.5	300	277	325	299.5	350	322	375	344.5	400	367	425	389.5	425	412	450
12	210.5	275	246	300	268.5	325	291	350	313.5	350	336	375	358.5	400	381	425	403.5	450	229.5	300	265	325	287.5	325	310	350	332.5	375	355	400	377.5	425	400	450	422.5	475
13	221	275	256.5	300	279	325	301.5	350	324	375	346.5	400	369	425	391.5	450	414	450	240	300	275.5	325	298	350	320.5	375	343	400	365.5	425	388	425	410.5	450	433	475
14	231.5	300	267	325	289.5	325	312	350	334.5	375	357	400	379.5	425	402	450	424.5	475	250.5	300	286	325	308.5	350	331	375	353.5	400	376	425	398.5	450	421	475	443.5	500
15	242	300	277.5	325	300	350	322.5	375	345	400	367.5	425	390	450	412.5	450	435	475	261	325	296.5	350	319	375	341.5	400	364	400	386.5	425	409	450	431.5	475	454	500
16	252.5	325	288	325	310.5	350	333	375	355.5	400	378	425	400.5	450	423	475	445.5	500	271.5	325	307	350	329.5	375	352	400	374.5	425	397	450	419.5	475	442	500	464.5	500
17	263	325	298.5	350	321	375	343.5	400	366	425	388.5	425	411	450	433.5	475	456	500	282	350	317.5	375	340	400	362.5	400	385	425	407.5	450	430	475	452.5	500	475	525
18	273.5	325	309	350	331.5	375	354	400	376.5	425	399	450	421.5	475	444	500	466.5	525	292.5	350	328	375	350.5	400	373	425	395.5	450	418	475	440.5	500	463	500	485.5	525
19	284	350	319.5	375	342	400	364.5	400	387	425	409.5	450	432	475	454.5	500	477	525	303	375	338.5	375	361	400	383.5	425	406	450	428.5	475	451	500	473.5	525	496	550
20	294.5	350	330	375	352.5	400	375	425	397.5	450	420	475	442.5	500	465	525	487.5	525	313.5	375	349	400	371.5	425	394	450	416.5	475	439	475	461.5	500	484	525	506.5	550

● F10 Series Easy Assembly Manifold with I/O Terminal

F10M Valve units **XT** M Pilot specification (base piping type)

Manifold outlet port with dual use fitting block
(EtherCAT, EtherNet/IP) * The figures show EtherCAT.

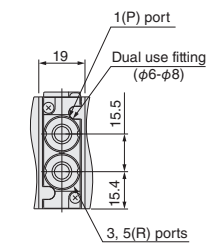
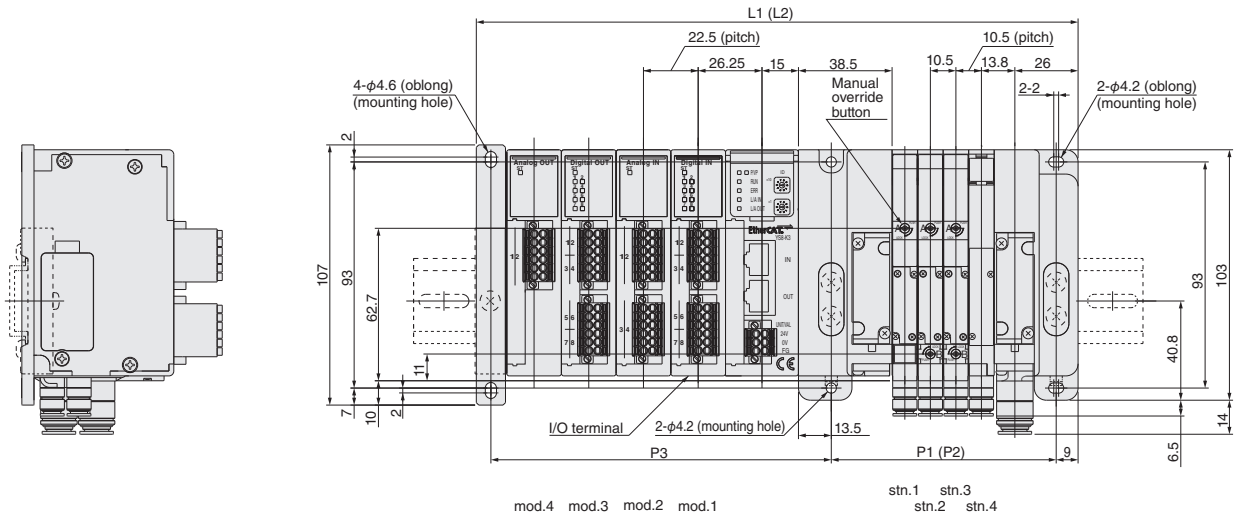

When -JT is selected (F10ZX-PJ-TK-□)

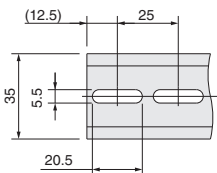

-DR: DIN rail mounting hole dimensions

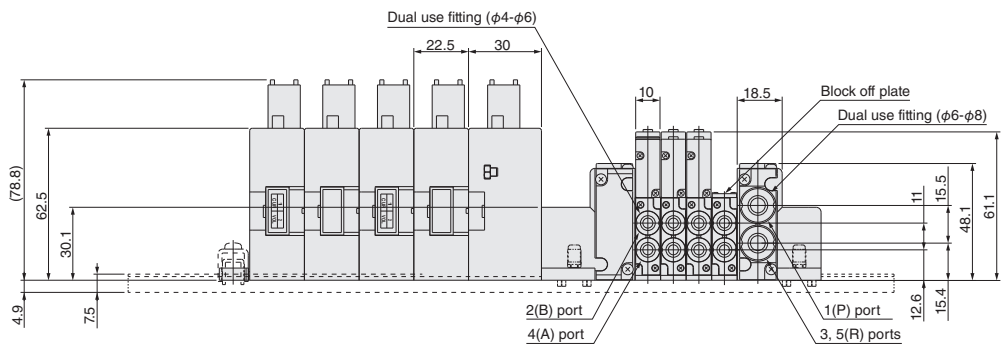

Examples of models in illustration

F10M4XTJ-JR-K3-4-W

- stn.1 F10T1-A1/DC24V mod.1 YS8-D8N
- stn.2 F10T2-A1/DC24V mod.2 YS8-A4N
- stn.3 F10T3-A1/DC24V mod.3 YS8-D8S
- stn.4 F10XBPP mod.4 YS8-A2S

Number of mods	If without intermediate piping block																If with intermediate piping block																					
	0		1		2		3		4		5		6		7		8		0		1		2		3		4		5		6		7		8			
	P3	L1	DIN	L1	DIN	L1	DIN	L1	DIN	L1	DIN	L1	DIN	L1	DIN	L1	DIN	L1	DIN	L2	DIN	L2	DIN	L2	DIN	L2	DIN	L2	DIN	L2	DIN	L2	DIN	P2				
2	124	175	159	200	181.5	225	204	250	226.5	275	249	300	271.5	325	294	350	316.5	375	71.5	-	-	-	-	-	-	-	-	-	-	-	-	-	-	-	-			
3	134.5	200	169.5	225	192	250	214.5	275	237	275	259.5	300	282	325	304.5	350	327	375	82	143	200	178	225	200.5	250	223	275	245.5	300	268	325	290.5	350	313	350	335.5	375	90.5
4	145	200	180	225	202.5	250	225	275	247.5	300	270	325	292.5	350	315	375	337.5	375	92.5	153.5	225	188.5	225	211	250	233.5	275	256	300	278.5	325	301	350	323.5	375	346	400	101
5	155.5	225	190.5	250	213	250	235.5	275	258	300	280.5	325	303	350	325.5	375	348	400	103	164	225	199	250	221.5	275	244	300	266.5	325	289	325	311.5	350	334	375	356.5	400	111.5
6	166	225	201	250	223.5	275	246	300	268.5	325	291	350	313.5	350	336	375	358.5	400	113.5	174.5	225	209.5	250	232	275	254.5	300	277	325	299.5	350	322	375	344.5	400	367	425	122
7	176.5	225	211.5	250	234	275	256.5	300	279	325	301.5	350	324	375	346.5	400	369	425	124	185	250	220	275	242.5	300	265	325	287.5	325	310	350	332.5	375	355	400	377.5	425	132.5
8	187	250	222	275	244.5	300	267	325	289.5	350	312	350	334.5	375	357	400	379.5	425	134.5	195.5	250	230.5	275	253	300	275.5	325	298	350	320.5	375	343	400	365.5	425	388	425	143
9	197.5	250	232.5	275	255	300	277.5	325	300	350	322.5	375	345	400	367.5	425	390	450	145	206	275	241	300	263.5	300	286	325	308.5	350	331	375	353.5	400	376	425	398.5	450	153.5
10	208	275	243	300	265.5	325	288	325	310.5	350	333	375	355.5	400	378	425	400.5	450	155.5	216.5	275	251.5	300	274	325	296.5	350	319	375	341.5	400	364	400	386.5	425	409	450	164
11	218.5	275	253.5	300	276	325	298.5	350	321	375	343.5	400	366	425	388.5	425	411	450	166	227	300	262	300	284.5	325	307	350	329.5	375	352	400	374.5	425	397	450	419.5	475	174.5
12	229	300	264	300	286.5	325	309	350	331.5	375	354	400	376.5	425	399	450	421.5	475	176.5	237.5	300	272.5	325	295	350	317.5	375	340	400	362.5	400	385	425	407.5	450	430	475	185
13	239.5	300	274.5	325	297	350	319.5	375	342	400	364.5	425	387	425	409.5	450	432	475	187	248	300	283	325	305.5	350	328	375	350.5	400	373	425	395.5	450	418	475	440.5	500	195.5
14	250	300	285	325	307.5	350	330	375	352.5	400	375	425	397.5	450	420	475	442.5	500	197.5	258.5	325	293.5	350	316	375	338.5	375	361	400	383.5	425	406	450	428.5	475	451	500	206
15	260.5	325	295.5	350	318	375	340.5	400	363	400	385.5	425	408	450	430.5	475	453	500	208	269	325	304	350	326.5	375	349	400	371.5	425	394	450	416.5	475	439	475	461.5	500	216.5
16	271	325	306	350	328.5	375	351	400	373.5	425	396	450	418.5	475	441	500	463.5	500	218.5	279.5	350	314.5	375	337	375	359.5	400	382	425	404.5	450	427	475	449.5	500	472	525	227
17	281.5	350	316.5	375	339	375	361.5	400	384	425	406.5	450	429	475	451.5	500	474	525	229	290	350	325	375	347.5	400	370	425	392.5	450	415	475	437.5	475	460	500	482.5	525	237.5
18	292	350	327	375	349.5	400	372	425	394.5	450	417	475	439.5	500	462	500	484.5	525	239.5	300.5	350	335.5	375	358	400	380.5	425	403	450	425.5	475	448	500	470.5	525	493	550	248
19	302.5	375	337.5	375	360	400	382.5	425	405	450	427.5	475	450	500	472.5	525	495	550	250	311	375	346	400	368.5	425	391	450	413.5	450	436	475	458.5	500	481	525	503.5	550	258.5
20	313	375	348	400	370.5	425	393	450	415.5	475	438	475	460.5	500	483	525	505.5	550	260.5	321.5	375	356.5	400	379	425	401.5	450	424	475	446.5	500	469	525	491.5	550	514	550	269
21	-	-	-	-	-	-	-	-	-	-	-	-	-	-	-	-	-	-	332	400	367	425	389.5	450	412	450	434.5	475	457	500	479.5	525	502	550	524.5	575	279.5	

Dimensions (mm)

● F15 Series Split Manifold with I/O Terminal

F15M Valve units **T** M **L** Pilot specification (base piping type)

Manifold outlet port with dual use fitting block
(EtherCAT, EtherNet/IP) * The figures show EtherCAT.

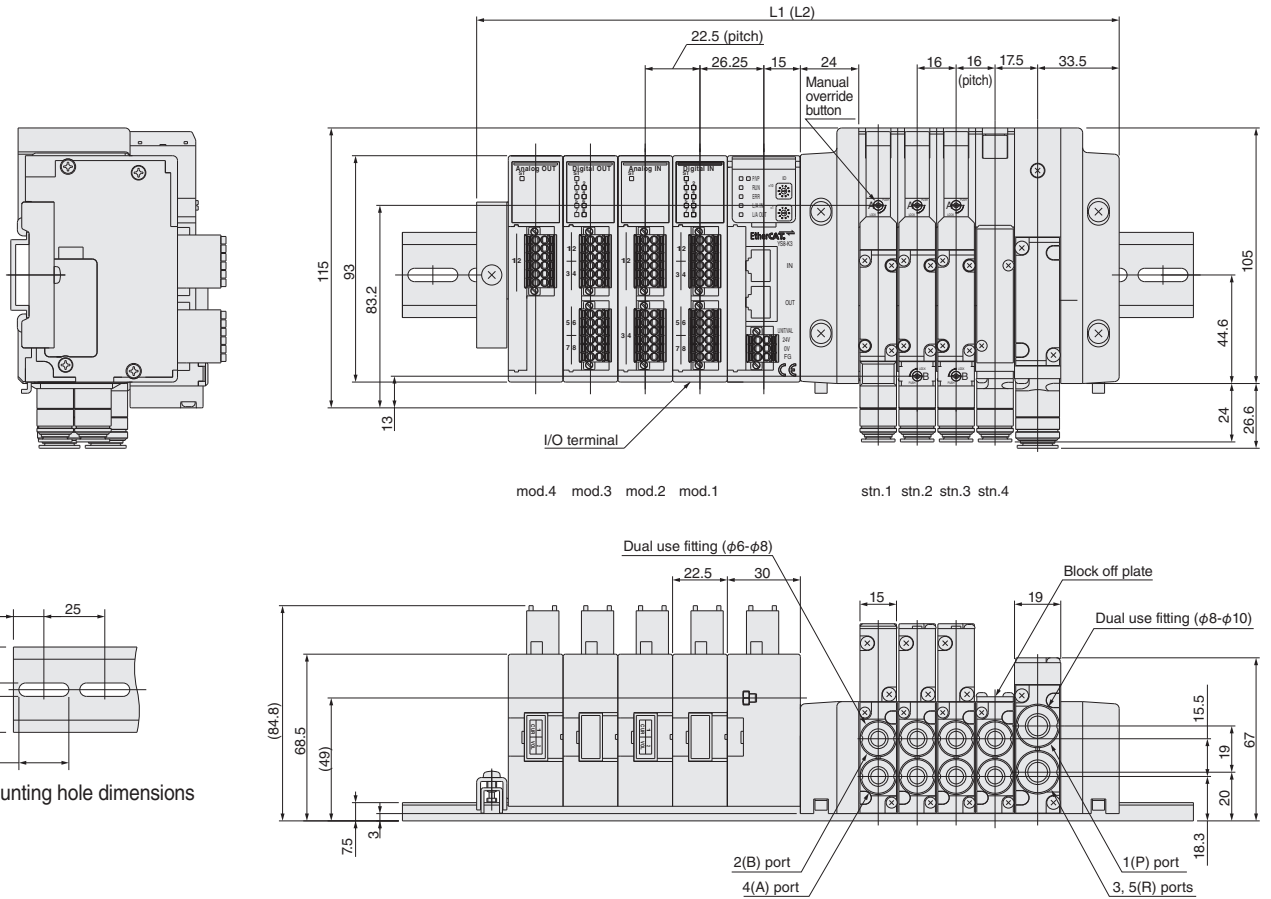

DIN rail mounting hole dimensions

Examples of models in illustration

- F15M4TJ-JR-K3-4-W
- | | | | |
|-------|----------------|-------|---------|
| stn.1 | F15T1-A1/DC24V | mod.1 | YS8-D8N |
| stn.2 | F15T2-A1/DC24V | mod.2 | YS8-A4N |
| stn.3 | F15T3-A1/DC24V | mod.3 | YS8-D8S |
| stn.4 | F15XBPP | mod.4 | YS8-A2S |

		L1 For one piping block																L2 For two piping blocks																			
Number of units	Dimension location	0		1		2		3		4		5		6		7		8		0		1		2		3		4		5		6		7		8	
		L1	DIN	L1	DIN	L1	DIN	L1	DIN	L1	DIN	L1	DIN	L1	DIN	L1	DIN	L1	DIN	L2	DIN	L2	DIN	L2	DIN	L2	DIN	L2	DIN	L2	DIN	L2	DIN	L2	DIN		
2	129	200	164.5	225	187	250	209.5	275	232	275	254.5	300	277	325	299.5	350	322	375	148	225	183.5	225	206	250	228.5	275	251	300	273.5	325	296	350	318.5	375	341	400	
3	145	200	180.5	225	203	250	225.5	275	248	300	270.5	325	293	350	315.5	375	338	400	164	225	199.5	250	222	275	244.5	300	267	325	289.5	350	312	375	334.5	400	357	400	
4	161	225	196.5	250	219	275	241.5	300	264	325	286.5	350	309	375	331.5	375	354	400	180	250	215.5	275	238	300	260.5	325	283	325	305.5	350	328	375	350.5	400	373	425	
5	177	250	212.5	275	235	300	257.5	300	280	325	302.5	350	325	375	347.5	400	370	425	196	275	231.5	275	254	300	276.5	325	299	350	321.5	375	344	400	366.5	425	389	450	
6	193	250	228.5	275	251	300	273.5	325	296	350	318.5	375	341	400	363.5	425	386	450	212	275	247.5	300	270	325	292.5	350	315	375	337.5	400	360	425	382.5	425	405	450	
7	209	275	244.5	300	267	325	289.5	350	312	375	334.5	400	357	400	379.5	425	402	450	228	300	263.5	325	286	350	308.5	350	331	375	353.5	400	376	425	398.5	450	421	475	
8	225	300	260.5	325	283	325	305.5	350	328	375	350.5	400	373	425	395.5	450	418	475	244	300	279.5	325	302	350	324.5	375	347	400	369.5	425	392	450	414.5	475	437	500	
9	241	300	276.5	325	299	350	321.5	375	344	400	366.5	425	389	450	411.5	475	434	500	260	325	295.5	350	318	375	340.5	400	363	425	385.5	450	408	450	430.5	475	453	500	
10	257	325	292.5	350	315	375	337.5	400	360	425	382.5	425	405	450	427.5	475	450	500	276	350	311.5	375	334	400	356.5	400	379	425	401.5	450	424	475	446.5	500	469	525	
11	273	350	308.5	350	331	375	353.5	400	376	425	398.5	450	421	475	443.5	500	466	525	292	350	327.5	375	350	400	372.5	425	395	450	417.5	475	440	500	462.5	525	485	550	
12	289	350	324.5	375	347	400	369.5	425	392	450	414.5	475	437	500	459.5	525	482	525	308	375	343.5	400	366	425	388.5	450	411	475	433.5	475	456	500	478.5	525	501	550	
13	305	375	340.5	400	363	425	385.5	450	408	450	430.5	475	453	500	475.5	525	498	550	324	400	359.5	425	382	425	404.5	450	427	475	449.5	500	472	525	494.5	550	517	575	
14	321	400	356.5	400	379	425	401.5	450	424	475	446.5	500	469	525	491.5	550	514	575	340	400	375.5	425	398	450	420.5	475	443	500	465.5	525	488	550	510.5	575	533	575	
15	337	400	372.5	425	395	450	417.5	475	440	500	462.5	525	485	550	507.5	550	530	575	356	425	391.5	450	414	475	436.5	500	459	525	481.5	525	504	550	526.5	575	549	600	
16	353	425	388.5	450	411	475	433.5	475	456	500	478.5	525	501	550	523.5	575	546	600	372	450	407.5	450	430	475	452.5	500	475	525	497.5	550	520	575	542.5	600	565	625	
17	369	425	404.5	450	427	475	449.5	500	472	525	494.5	550	517	575	539.5	600	562	625	388	450	423.5	475	446	500	468.5	525	491	550	513.5	575	536	600	558.5	600	581	625	
18	385	450	420.5	475	443	500	465.5	525	488	550	510.5	575	533	575	555.5	600	578	625	404	475	439.5	500	462	525	484.5	550	507	550	529.5	575	552	600	574.5	625	597	650	
19	401	475	436.5	500	459	525	481.5	525	504	550	526.5	575	549	600	571.5	625	594	650	420	475	455.5	500	478	525	500.5	550	523	575	545.5	600	568	625	590.5	650	613	675	
20	417	475	452.5	500	475	525	497.5	550	520	575	542.5	600	565	625	587.5	650	610	675	436	500	471.5	525	494	550	516.5	575	539	600	561.5	625	584	650	606.5	650	629	675	

Dimensions (mm)

F15 Series Easy Assembly Manifold with I/O Terminal

F15M Valve units J XT M Pilot specification (base piping type)

Manifold outlet port with dual use fitting block
(EtherCAT, EtherNet/IP) * The figures show EtherCAT.

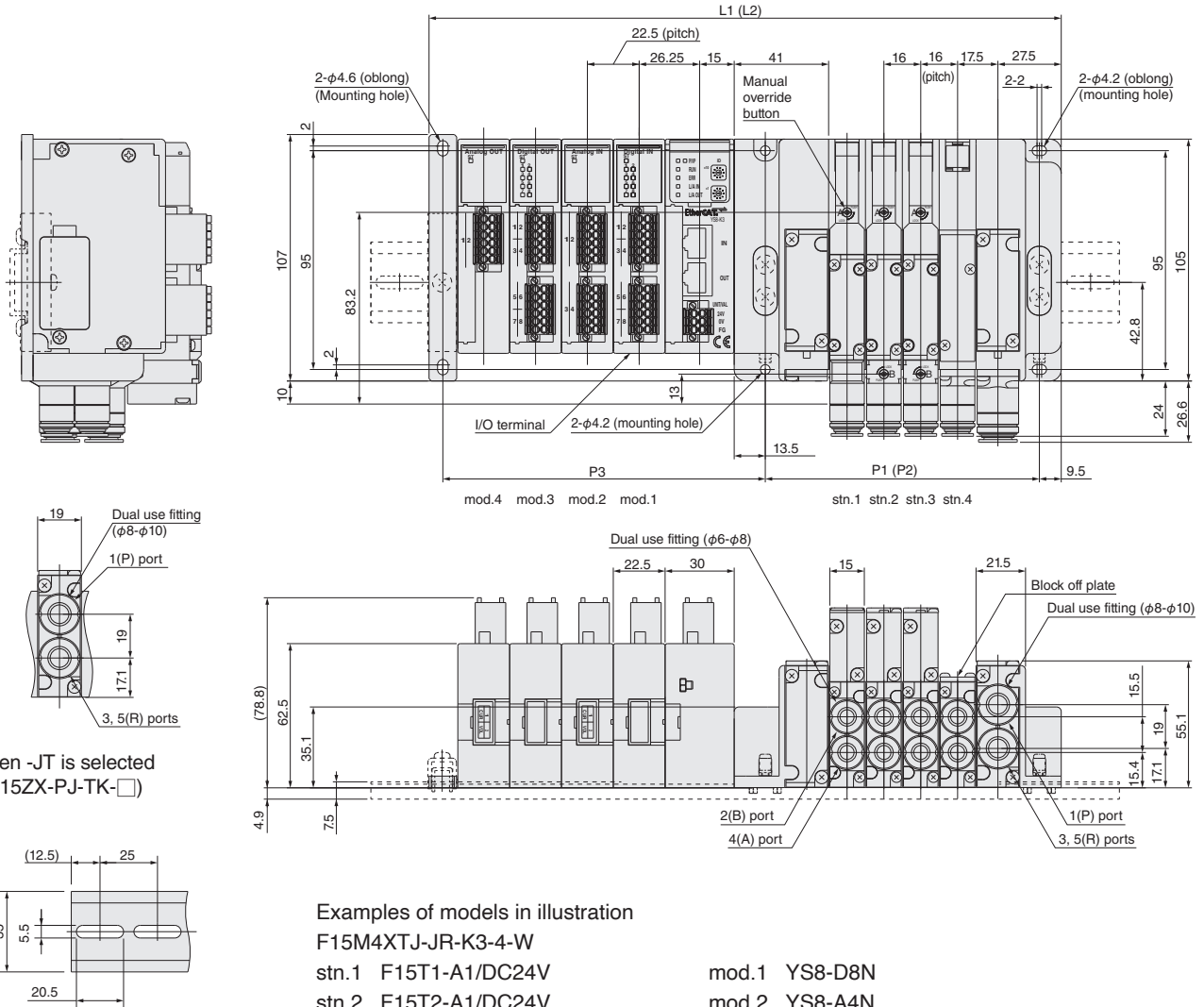

When -JT is selected (F15ZX-PJ-TK-□)

Examples of models in illustration

- | | | |
|----------------------|-------|---------|
| F15M4XTJ-JR-K3-4-W | mod.1 | YS8-D8N |
| stn.1 F15T1-A1/DC24V | mod.2 | YS8-A4N |
| stn.2 F15T2-A1/DC24V | mod.3 | YS8-D8S |
| stn.3 F15T3-A1/DC24V | mod.4 | YS8-A2S |
| stn.4 F15xBPP | | |

-DR: DIN rail mounting hole dimensions

Number of mods	If without intermediate piping block																	If with intermediate piping block																				
	0		1		2		3		4		5		6		7		8		0		1		2		3		4		5		6		7		8			
	P3	L1	DIN	L1	DIN	L1	DIN	L1	DIN	L1	DIN	L1	DIN	L1	DIN	L1	DIN	L1	DIN	L2	DIN	L2	DIN	L2	DIN	L2	DIN	L2	DIN	L2	DIN	L2	DIN	P2				
2	140	200	175	225	197.5	250	220	275	242.5	300	265	325	287.5	350	310	375	332.5	375	87	-	-	-	-	-	-	-	-	-	-	-	-	-	-	-	-			
3	156	225	191	250	213.5	275	236	300	258.5	300	281	325	303.5	350	326	375	348.5	400	103	159	225	194	250	216.5	275	239	300	261.5	325	284	350	306.5	350	329	375	351.5	400	106
4	172	250	207	250	229.5	275	252	300	274.5	325	297	350	319.5	375	342	400	364.5	425	119	175	250	210	275	232.5	275	255	300	277.5	325	300	350	322.5	375	345	400	367.5	425	122
5	188	250	223	275	245.5	300	268	325	290.5	350	313	375	335.5	400	358	400	380.5	425	135	191	250	226	275	248.5	300	271	325	293.5	350	316	375	338.5	400	361	425	383.5	425	138
6	204	275	239	300	261.5	325	284	350	306.5	350	329	375	351.5	400	374	425	396.5	450	151	207	275	242	300	264.5	325	287	350	309.5	375	332	375	354.5	400	377	425	399.5	450	154
7	220	275	255	300	277.5	325	300	350	322.5	375	345	400	367.5	425	390	450	412.5	475	167	223	300	258	300	280.5	325	303	350	325.5	375	348	400	370.5	425	393	450	415.5	475	170
8	236	300	271	325	293.5	350	316	375	338.5	400	361	425	383.5	425	406	450	428.5	475	183	239	300	274	325	296.5	350	319	375	341.5	400	364	425	386.5	450	409	475	431.5	475	186
9	252	325	287	350	309.5	375	332	375	354.5	400	377	425	399.5	450	422	475	444.5	500	199	255	325	290	350	312.5	375	335	400	357.5	400	380	425	402.5	450	425	475	447.5	500	202
10	268	325	303	350	325.5	375	348	400	370.5	425	393	450	415.5	475	438	500	460.5	525	215	271	325	306	350	328.5	375	351	400	373.5	425	396	450	418.5	475	441	500	463.5	525	218
11	284	350	319	375	341.5	400	364	425	386.5	450	409	475	431.5	475	454	500	476.5	525	231	287	350	322	375	344.5	400	367	425	389.5	450	412	475	434.5	500	457	500	479.5	525	234
12	300	375	335	400	357.5	400	380	425	402.5	450	425	475	447.5	500	470	525	492.5	550	247	303	375	338	400	360.5	425	383	425	405.5	450	428	475	450.5	500	473	525	495.5	550	250
13	316	375	351	400	373.5	425	396	450	418.5	475	441	500	463.5	525	486	550	508.5	550	263	319	375	354	400	376.5	425	399	450	421.5	475	444	500	466.5	525	489	550	511.5	575	256
14	332	400	367	425	389.5	450	412	475	434.5	500	457	500	479.5	525	502	550	524.5	575	279	335	400	370	425	392.5	450	415	475	437.5	500	460	525	482.5	525	505	550	527.5	575	282
15	348	425	383	425	405.5	450	428	475	450.5	500	473	525	495.5	550	518	575	540.5	600	295	351	425	386	450	408.5	450	431	475	453.5	500	476	525	498.5	550	521	575	543.5	600	298
16	364	425	399	450	421.5	475	444	500	466.5	525	489	550	511.5	575	534	600	556.5	600	311	367	425	402	450	424.5	475	447	500	469.5	525	492	550	514.5	575	537	600	559.5	625	314
17	380	450	415	475	437.5	500	460	525	482.5	525	505	550	527.5	575	550	600	572.5	625	327	383	450	418	475	440.5	500	463	525	485.5	550	508	550	530.5	575	553	600	575.5	625	330
18	396	450	431	475	453.5	500	476	525	498.5	550	521	575	543.5	600	566	625	588.5	650	343	399	475	434	500	456.5	500	479	525	501.5	550	524	575	546.5	600	569	625	591.5	650	346
19	412	475	447	500	469.5	525	492	550	514.5	575	537	600	559.5	625	582	625	604.5	650	359	415	475	450	500	472.5	525	495	550	517.5	575	540	600	562.5	625	585	650	607.5	650	362
20	428	500	463	525	485.5	550	508	550	530.5	575	553	600	575.5	625	598	650	620.5	675	375	431	500	466	525	488.5	550	511	575	533.5	575	556	600	578.5	625	601	650	623.5	675	378
21	-	-	-	-	-	-	-	-	-	-	-	-	-	-	-	-	-	-	447	525	482	525	504.5	550	527	575	549.5	600	572	625	594.5	650	617	675	639.5	700	394	

Limited Warranty

KOGANEI CORP. warrants its products to be free from defects in material and workmanship subject to the following provisions.

Warranty Period The warranty period is 180 days from the date of delivery.

Koganei Responsibility If a defect in material or workmanship is found during the warranty period, KOGANEI CORP. will replace any part proved defective under normal use free of charge and will provide the service necessary to replace such a part.

Limitations

- This warranty is in lieu of all other warranties, expressed or implied, and is limited to the original cost of the product and shall not include any transportation fee, the cost of installation or any liability for direct, indirect or consequential damage or delay resulting from the defects.

- KOGANEI CORP. shall in no way be liable or responsible for injuries or damage to persons or property arising out of the use or operation of the manufacturer's product.

- This warranty shall be void if the engineered safety devices are removed, made inoperative or not periodically checked for proper functioning.

- Any operation beyond the rated capacity, any improper use or application, or any improper installation of the product, or any substitution upon it with parts not furnished or approved by KOGANEI CORP., shall void this warranty.

- This warranty covers only such items supplied by KOGANEI CORP. The products of other manufacturers are covered only by such warranties made by those original manufacturers, even though such items may have been included as the components.

The specifications are subject to change without notice.

URL: <http://www.koganeiusa.com>

E-mail: sales@koganeiusa.com



KOGANEI CORPORATION

OVERSEAS DEPARTMENT

3-11-28, Midori-cho, Koganei City, Tokyo 184-8533, Japan
Tel: 81-42-383-7271 Fax: 81-42-383-7276

KOGANEI INTERNATIONAL AMERICA, INC.

48860 Milmont Drive, Suite 108C, Fremont, California 94538
Tel: 1-510-744-1626 Fax: 1-510-744-1676

SHANGHAI KOGANEI INTERNATIONAL TRADING CORPORATION

Room 2606-2607, Tongda Venture Building No.1, Lane 600, Tianshan Road,
Shanghai, 200051, China
Tel: 86-21-6145-7313 Fax: 86-21-6145-7323

TAIWAN KOGANEI TRADING CO., LTD.

Rm. 2, 13F., No88, Sec. 2, Zhongxiao E. Rd., Zhongzheng Dist., Taipei City 100,
Taiwan (ROC)
Tel: 886-2-2393-2717 Fax: 886-2-2393-2719

KOGANEI KOREA CO., LTD.

6F-601, Tower Bldg., 1005, Yeongdeong-dong, Giheung-gu, Yongin-si, Gyeonggi-do,
446-908, Korea
Tel: 82-31-246-0414 Fax: 82-31-246-0415

KOGANEI (THAILAND) CO., LTD.

3300/90, Tower B, Elephant Tower, 16th Fl., Phaholyothin Road, Chomphon,
Chatuchak, Bangkok 10900, Thailand
Tel: 66-2-937-4250 Fax: 66-2-937-4254

KOGANEI AUTOMATION (MALAYSIA) SDN.BHD.

Suite 29-2, Level 29, Menara 1MK, No.1, Jalan Kiara, Mont Kiara
50480, Kuala Lumpur, Malaysia
Tel: 60-12-537-7086

KOGANEI ASIA PTE. LTD.

69 Ubi Road 1, #05-18 Oxley Bizhub, Singapore 408731
Tel: 65-6293-4512 Fax: 65-6293-4513