

In-Line Filter

- PLF Series (0.01 μm)
- CLF Series (0.01 μm)
- VLF Series (5 μm)
- VSF Series (5 μm)

PLF Series

NEW PLF300 Added!!

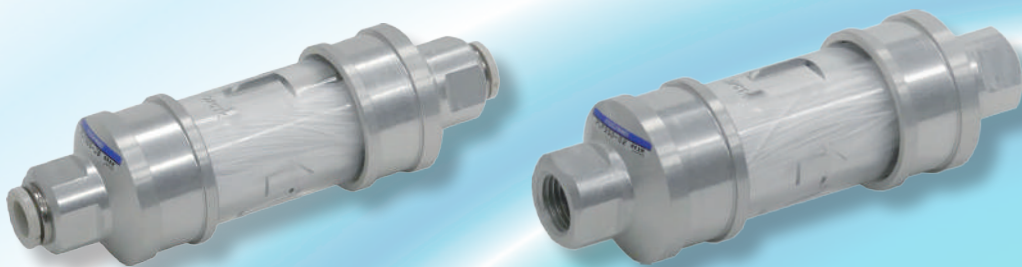

NEW PLF050N/100N



CLF Series



VLF Series



VSF Series



In-Line Filter Series

0.01- μm filtration rating **PLF Series** Page ⑦



- Uses porous hollow fiber membrane element
 - Uses fluoro-type hollow fiber membrane and fluoro rubber for ozone resistant specifications
 - For both positive and negative pressure (PLF300, PLF600)
 - Uses highly chemical resistant PCT for plastic housing material
- Improved resistance to cutting oils and alcohol

| μm filtration rating | Model | Piping port | | Process air volume L/min (ANR) [ft ³ /min (SCFM)] ^{Note} | Particle filtering efficiency % | Positive pressure | Negative pressure |
|---------------------------------|---------------|---------------|-------------------|--|---------------------------------|-------------------|-------------------|
| 0.01 | PLF050N | Female thread | M5x0.8 | 40 [1.413] | 99.99 | ○ | - |
| | PLF100N | Female thread | Rc1/8 | 100 [3.532] | 99.99 | ○ | - |
| | PLF300-J6 | Quick fitting | $\phi 6$ [0.236] | 150 [5.298] | 99.99 | ○ | ○ |
| | PLF300-J8 | Quick fitting | $\phi 8$ [0.315] | 200 [7.064] | | ○ | ○ |
| | PLF300-02 | Female thread | Rc1/4 | 300 [10.596] | 99.99 | ○ | ○ |
| | PLF600-J8 | Quick fitting | $\phi 8$ [0.315] | 300 [10.596] | | ○ | ○ |
| | PLF600-J10 | Quick fitting | $\phi 10$ [0.394] | 450 [15.894] | | ○ | ○ |
| | PLF600-02 | Female thread | Rc 1/4 | 550 [19.426] | | ○ | ○ |
| PLF600-03 | Female thread | Rc 3/8 | 600 [21.192] | ○ | | ○ | |

Note: Recommended maximum flow rate at primary side pressure 0.7 MPa [102 psi]

0.01- μm filtration rating **CLF Series** Page ⑱



- For microfiltration of general-purpose gases in clean rooms
- Dual-layer structure with a PTFE membrane and a PTFE non-woven fabric
- Structural materials have superior resistance to corrosion. Can be used for general-purpose gases
- Integrity testing, airtightness testing, cleanliness, and clean packing implemented for CLF series

| μm filtration rating | Model | Piping port | | Process air volume L/min (ANR) [ft ³ /min (SCFM)] ^{Note} | Particle filtering efficiency % | Positive pressure | Negative pressure |
|---------------------------------|--------|---------------|-----------------------|--|---------------------------------|-------------------|-------------------|
| 0.01 | CLF050 | Female thread | 01: Rc 1/8 02: Rc 1/4 | 50 [1.766] | 100 | ○ | - |

Note 1: Process air volume when primary side pressure is 0.7 MPa [102 psi] (pressure drop of 0.03 MPa [4 psi], maximum connection port diameter). See flow rate characteristics on page ⑲ for details.



5- μ m filtration rating

VLF Series Page 21



- Prefilter can be used for vacuum or positive pressure
- Elements can be replaced without tools and maintenance is easy!
- Applicable tube outer diameters: ϕ 4 [0.157], ϕ 6 [0.236], ϕ 8 [0.315], and ϕ 10 [0.394]
- Lineup includes ozone resistant, secondary battery production line compatible SUS303 specifications

| μ m filtration rating | Model | Piping port | | Process air volume L/min (ANR) [ft ³ /min (SCFM)] ^{Note} | Particle filtering efficiency % | Positive pressure | Negative pressure |
|---------------------------|------------|---------------|-------------------|--|---------------------------------|-------------------|-------------------|
| | | | | | | | |
| 5 | VLF010-J4 | Quick fitting | ϕ 4 [0.157] | 140 [4.945] | 95 | ○ | ○ |
| | VLF020-J4 | Quick fitting | ϕ 4 [0.157] | 165 [5.828] | | ○ | ○ |
| | VLF010-J6 | Quick fitting | ϕ 6 [0.236] | 210 [7.417] | | ○ | ○ |
| | VLF020-J6 | Quick fitting | ϕ 6 [0.236] | 310 [10.949] | | ○ | ○ |
| | VLF050-J6 | Quick fitting | ϕ 6 [0.236] | 400 [14.128] | | ○ | ○ |
| | VLF050-J8 | Quick fitting | ϕ 8 [0.315] | 750 [26.490] | | ○ | ○ |
| | VLF050-J10 | Quick fitting | ϕ 10 [0.394] | 900 [31.788] | | ○ | ○ |

Note: Recommended maximum flow rate at primary side pressure 0.7 MPa [102 psi]

5- μ m filtration rating

VSF Series Page 26



- Prefilter can be used for vacuum lines
- Filter is internally integrated in socket-type fitting
- Applicable tube outer diameters: ϕ 3 [0.118], ϕ 4 [0.157], and ϕ 6 [0.236]

| μ m filtration rating | Model | Piping port | | Process air volume L/min (ANR) [ft ³ /min (SCFM)] ^{Note} | Particle filtering efficiency % | Positive pressure | Negative pressure |
|---------------------------|--------|-----------------------------|-------------------------------------|--|---------------------------------|-------------------|-------------------|
| | | | | | | | |
| 5 | VSF-J3 | Fitting/tube outer diameter | ϕ 3 [0.118] - ϕ 3 [0.118] | Vacuum flow rate 5 [0.177] | 95 | - | ○ |
| | VSF-J4 | Fitting/tube outer diameter | ϕ 4 [0.157] - ϕ 4 [0.157] | Vacuum flow rate 7.5 [0.265] | | - | ○ |
| | VSF-J6 | Fitting/tube outer diameter | ϕ 6 [0.236] - ϕ 6 [0.236] | Vacuum flow rate 11 [0.389] | | - | ○ |

Note: Recommended maximum flow rate at primary side pressure 0.7 MPa [102 psi]

About air supply to in-line filters

● The objective of in-line filters is to remove solid matter, so water and oil must be removed first. Examples for removing water and oil are shown below. For detailed information about selecting a system, see Catalog No. E4051 "Filter regulator FRZ Series and Combination CMZ Series".

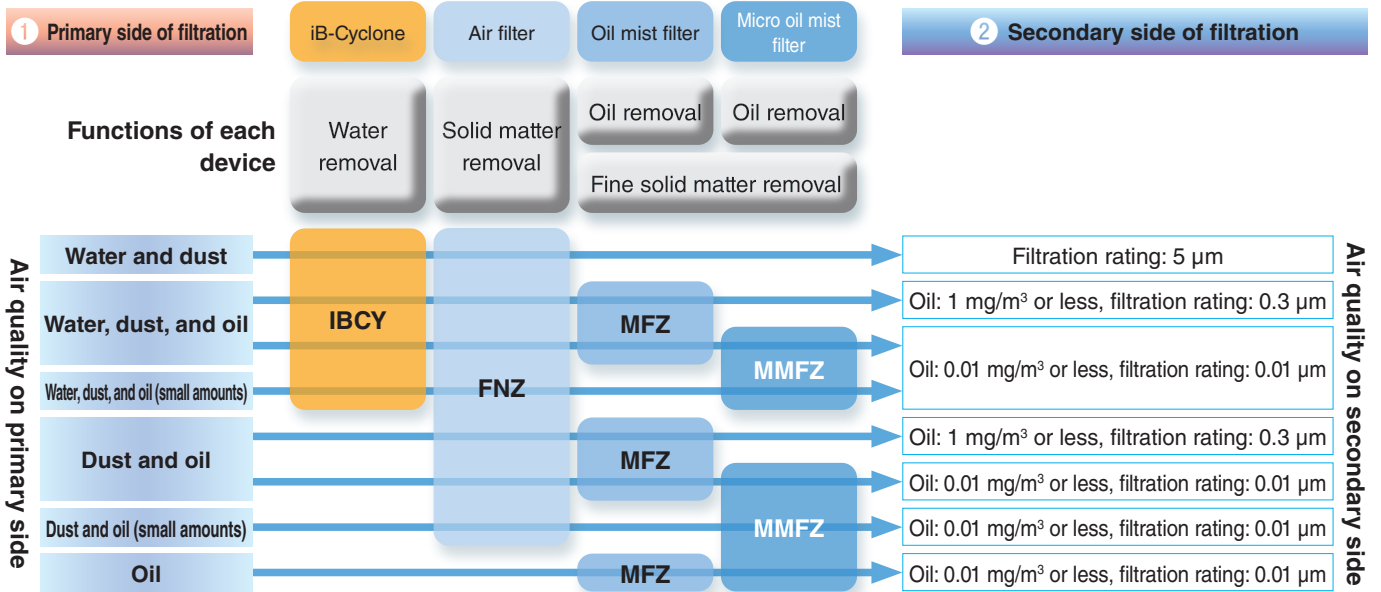

<Selection procedure>

- ① Confirm quality of air used on primary side
- ② Confirm air quality needed on secondary side
- ③ Decide configuration of devices needed for conditions in ① and ②

CMZF550 — CFMD — □ — □ PG

└─┬─┘

Configured device code





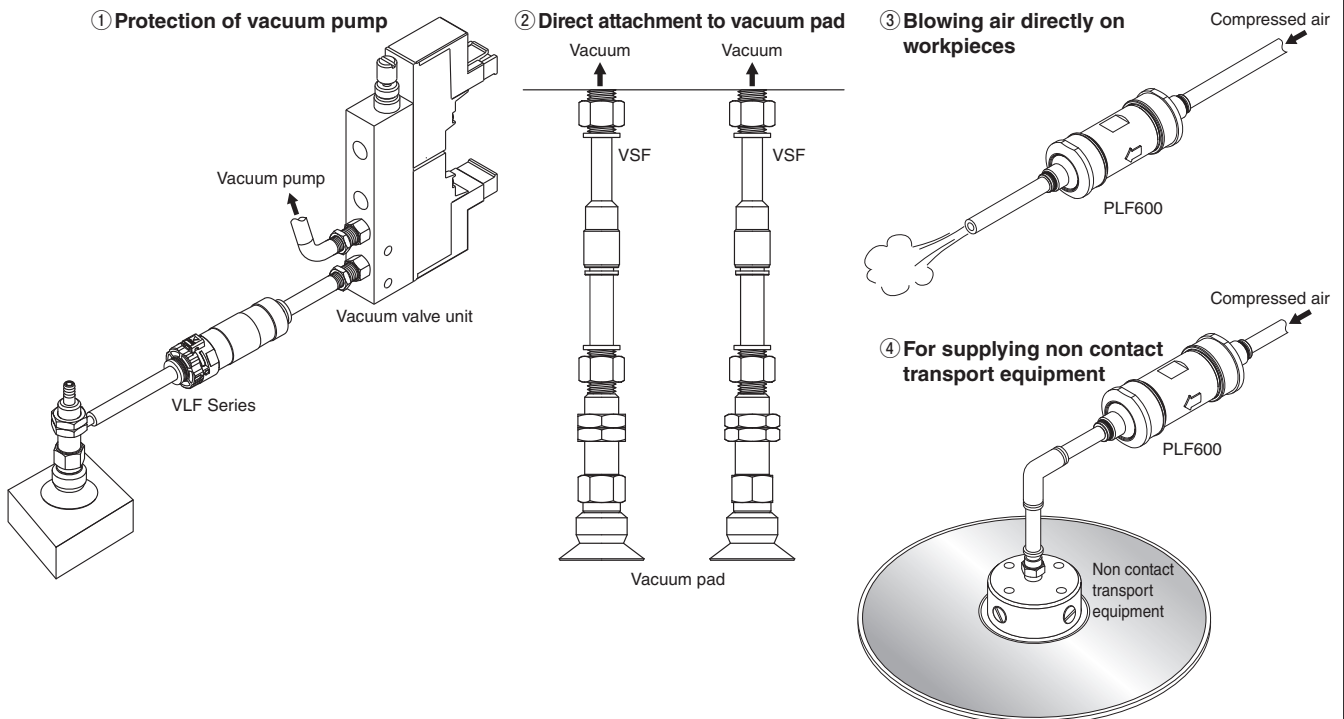

Application example



Before selecting and using products, please read all the Safety Precautions carefully to ensure proper product use. The Safety Precautions shown below are to help you use the product safely and correctly, and to prevent injury or damage to assets. Always adhere to the following safety regulations: ISO4414 (Pneumatic fluid power - General rules and safety requirements for systems and their components) and JIS B 8370 (Pneumatic system regulations).

The directions are classified according to the degree of potential danger or damage as **DANGER**, **WARNING**, **CAUTION**, and **ATTENTION**.

| | |
|--|---|
|  DANGER | Indicates situations that can be clearly predicted as dangerous. Death or serious injury may result if the situation is not avoided. It could also result in damage or destruction of assets. |
|  WARNING | Indicates situations that, while not immediately dangerous, could become dangerous. Death or serious injury may result if the situation is not avoided. It could also result in damage or destruction of assets. |
|  CAUTION | Indicates situations that, while not immediately dangerous, could become dangerous. Minor or semi-serious injury may result if the situation is not avoided. It could also result in damage or destruction of assets. |
|  ATTENTION | While there is no chance of injury, these points should be observed for appropriate use of the product. |

■ This product was designed and manufactured as parts for use in general industrial machinery.

- In the selection and handling of the equipment, the system designer or other responsible person with fully adequate knowledge and experience should always read the Safety Precautions, Catalog, Owner’s Manual and other literature before commencing operation. Incorrect handling is dangerous.
- After reading the Owner’s Manual, etc., always store them where they are easily available for reference to users of this product.
- If transferring or lending the product to another person, always attach the Owner’s Manual, etc., to the product where they are easily visible, to ensure that the new user can use the product safely and properly.
- The danger, warning, and caution items listed under these “Safety Precautions” do not cover all possible cases. Read the Catalog and Owner’s Manual carefully, and always keep safety first.

 **DANGER**

- Do not use the product for the purposes listed below:
 1. Medical equipment related to maintenance or management of human lives or bodies
 2. Mechanical devices or equipment designed for the purpose of moving or transporting people
 3. Critical safety components in mechanical devices
 This product has not been planned or designed for purposes that require high levels of safety. It could cause loss of human life.
- Do not use the product in locations with or near dangerous substances, such as flammable or ignitable substances. This product is not explosion-proof. It could ignite or burst into flames.
- When installing the product, always firmly support and secure it (including the workpiece) in place. Injury could result if the product overturns, falls, or is operated abnormally.
- Never attempt to modify the product. Abnormal operation could result in injury.
- Never attempt inappropriate disassembly, assembly, or repair of the product relating to its basic inner construction, performance, or functions. It could result in injury.
- Do not splash water on the product. Spraying the product with water, washing it, or using it in water could result in malfunction leading to injury.
- While the product is in operation, avoid touching it with your hands or otherwise approaching too close. Also, do not attempt to make any adjustments to internal or attached mechanisms, or to perform any type of adjustment (releasing slide locks, disconnecting tubes or sealed plugs, adjustment of the product’s mounting position, etc.) while the product is in operation. Injury could result if the product falls, is operated abnormally, or ejects the medium.

 **WARNING**

- Koganei products can be used under a variety of conditions. Therefore, the person responsible for system design must fully evaluate the products to determine compatibility with the system. The designer who determines the suitability of the system is responsible for guarantying the desired performance and safety of the system. Safe and reliable system configuration (e.g., failsafe) is required considering the possibility of equipment failure through adequate verification and evaluation of the specifications based on the latest catalog and other technical documents.
- Do not use the product in excess of its specification range. Using the product outside of its specified range could result in product breakdowns, stop of functions, or damage. It could also drastically reduce the operating life.
- Before supplying air to the product and starting operation, always conduct a safety check within the range of machine operations. Unintentional supply of air could result in injury caused by contact with moving parts.
- Do not throw the product into fire. The product could explode and/or release toxic gases.
- Do not sit on the product, place your foot on it, or place other objects on it. Doing so creates the risk of injury due to tripping or the product tipping over or falling, and erratic or runaway operation due to damage or breakage to the product.
- Before doing maintenance inspections, repairs, or replacement of any parts, always completely cut off all air and vacuum pressure connections, and confirm that the pressure in the product and connected pipes is atmospheric pressure. In particular, be aware that pressure remains in compressors, vacuum pumps, and air tanks. If residual air pressure remains inside the piping, the actuator could abruptly move and cause injury.
- Use safety circuits or system designs to prevent damage to machinery or injury to personnel when the machine is shut down abnormally due to emergency stop or power failure.

Safety precautions (in-line filter)

- Always check the catalog and other reference materials for correct product piping. Improper piping creates the risk of damage to and abnormal operation of the actuator.
- Do not use the product near the ocean, in direct sunlight, near mercury vapor lamps, or near equipment that generates ozone. Deterioration of rubber parts caused by ozone may reduce performance and functions or stop functions. (except for ozone resistant products)
- Do not use any medium that is not stipulated in the specifications. Using a non-specified medium could lead to loss of functions within a short period, sudden degradation in performance, or reduced operating life.
- Do not use in locations where there is a heat source nearby or that are subject to radiated heat.
- Do not use the product in locations subject to direct sunlight (ultraviolet radiation); in locations subjected to high temperature or humidity; in locations where dust, salt, or iron particles are present; or in locations with media and/or an ambient atmosphere that includes organic solvents, phosphate ester type hydraulic oil, sulfur dioxide gas, chlorine gas, acids, etc. Such uses could lead to loss of functions within a short period, sudden degradation in performance, or reduced operating life. For information about materials, see Major Parts and Materials.



CAUTION

- When installing the product, leave room for adequate working space around it. Failure to ensure adequate working space will make it more difficult to conduct daily inspections or maintenance, which could eventually lead to system shutdown or damage to the product.
- Do not scratch, dent, or deform the product by climbing on it, using it as a step, or placing objects on top of it. Doing so could damage or break the product, resulting in operation shutdown or degraded performance.
- Post "Work in Progress" signs when doing installations, adjustments, or other work, so that air is not supplied unintentionally. Unintended supply of air could cause sudden operation resulting in injury.
- Pneumatic equipment is not completely air-leak-free. Designs should take into consideration the capacity and retention time required for an application, such as retention of pressure (as well as vacuum) within a pressurized vessel. A reduction in retaining force could cause a workpiece to fall or slip out of position and damage the equipment or cause injury.



ATTENTION

- When considering using the product for applications that demand extreme safety, such as aviation facilities, combustion equipment, leisure equipment, safety devices, or in other ways predicted to greatly affect assets or human lives, or in situations or environments not described in the Catalog or Owner's Manual, etc., take sufficient safety precautions, such as by allowing ample rating and performance margins for the application and by implementing adequate safety measures, such as fail-safes. Also, be sure to consult us about such applications.
- Wear protective gloves, safety glasses, safety shoes, and other protective clothing as necessary to be safe when handling the product.
- When the product can no longer be used or is no longer necessary, dispose of it appropriately as industrial waste.
- Pneumatic equipment can exhibit degraded performance and function over its operating life. Always conduct daily inspections of the pneumatic equipment, and confirm that all requisite system functions are satisfactory, to prevent accidents from happening.

- For inquiries about the product, contact your nearest Koganei sales office or Koganei overseas department. The addresses and telephone numbers are shown on the back cover of this catalog.



OTHERS

- Always observe the following items.
 1. When using this product in a pneumatic system, use only genuine Koganei parts or compatible parts (recommended parts).
When doing maintenance or repairs, always use genuine Koganei parts or compatible parts (recommended parts). Use only specified procedures and methods.
 2. Never inappropriately disassemble or assemble the product in relation to its basic construction, performance, or functions.

Koganei bears no responsibility if all safety precautions are not properly observed.

Warranty and disclaimer

1. Warranty Period
The warranty period of Koganei products is one year from the date of delivery.
* Some products have a two-year warranty period. For details, contact the nearest Koganei sales office or Overseas Department.
2. Scope of Warranty and General Disclaimer
 - (1) If a failure attributable to Koganei is found in a product purchased from Koganei or an authorized retailer/dealer during the warranty period, Koganei will repair or replace it free of charge. For some products, a service life, such as the number of operations, may be specified in their warranty periods. For details, contact the nearest Koganei sales office or the Overseas Department.
 - (2) The Koganei product warranty covers that product alone. Consequently, Koganei is not responsible for any incidental damage (including costs incurred for the repair and replacement of the product) attributable to any failure of the Koganei product, decrease in function, or decrease in performance.
 - (3) Koganei is not responsible for any losses or for any damages to other machinery caused by breakdown, loss of function, or loss of performance of Koganei products.
 - (4) Koganei is not responsible for any losses due to use or storage of the product in a way that is outside of the product specifications prescribed in Koganei catalogs and instruction manuals, and/or due to actions that violate the mounting, installation, adjustment, maintenance or other safety precautions.
 - (5) Koganei is not responsible for any losses caused by breakdown of the product due to factors outside the responsibility of Koganei, including but not limited to fire, natural disaster, the actions of third parties, and intentional actions or errors by the purchaser.

In-line filter

PLF Series

Symbols

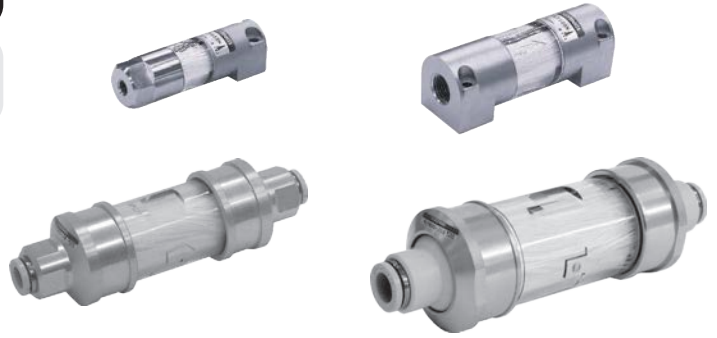
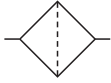

Specifications

| Item | | Model | | PLF300 | | PLF600 | | |
|---|--|---|------------|---------------------|------------------------|--|-------------------------|---|
| | | PLF050N | PLF100N | PLF300 | | PLF600 | | |
| Medium | | Air, N ₂ | | Air, N ₂ | | Air, N ₂ | | |
| Connection port diameter | | M5×0.8 | Rc1/8 | Female thread type | Rc1/4 | Female thread type | Rc1/4, Rc3/8 | |
| | | | | Quick fitting type | φ6 [0.236], φ8 [0.315] | Quick fitting type | φ8 [0.315], φ10 [0.394] | |
| Filtered particle size | | μm | | 0.01 | | 0.01 | | |
| Particle filtering efficiency | | % | | 99.99 | | 99.99 | | |
| Process air volume ^{Note 1} | | L/min (ANR) [ft ³ /min (SCFM)] | | 300 [10.596] | | 600 [21.192] | | |
| Operating pressure range | | Positive pressure | MPa [psi] | 0 to 1.0 [0 to 145] | | 0 to 1.0 [0 to 145] | | |
| | | Negative pressure | kPa [inHg] | - | | -100 to 0 [-29.540 to 0] | | |
| Proof pressure | | MPa [psi] | | 1.5 [218] | | 1.5 [218] | | |
| Proof pressure differential ^{Note 2} | | MPa [psi] | | 0.3 [44] | | 0.3 [44] | | |
| Operating temperature range | | °C [°F] | | 5 to 60 [41 to 140] | | 5 to 60 [41 to 140] | | |
| Weight | | g [oz] | 15 [0.53] | 35 [1.23] | Female thread type | PLF300-02: 85 [3.00] | Female thread type | PLF600-02: 160 [5.64] PLF600-03: 154 [5.43] |
| | | | | | Quick fitting type | PLF300-J6: 90 [3.17] PLF300-J8: 95 [3.35] | Quick fitting type | PLF600-J8: 130 [4.59] PLF600-J10: 136 [4.80] |

Note 1: Recommended maximum flow rate when primary side pressure is 0.7 MPa [102 psi] (pressure drop of 0.03 MPa [4 psi], maximum connection port diameter). See flow rate characteristics on [page 9](#) for details.

2: This is when momentary pressure differential occurs, normally use the product within the recommended maximum flow rate.

Order Codes

● PLF050N, PLF100N

PLF **N**

Main unit model
050 — M5×0.8
100 — Rc1/8

Connection port diameter

In-line filter

● PLF300

PLF 300 - **-**

Bracket
Blank: None
B: With bracket

Connection port diameter
02: Rc1/4 (Female thread type)
J6: φ6 [0.236] (Quick fitting type)
J8: φ8 [0.315] (Quick fitting type)

In-line filter

● PLF600

PLF 600 - **-**

Bracket
Blank: None
B: With bracket

Connection port diameter
02: Rc1/4 (Female thread type)
03: Rc3/8 (Female thread type)
J8: φ8 [0.315] (Quick fitting type)
J10: φ10 [0.394] (Quick fitting type)

In-line filter

Additional Parts (sold separately for PLF300 and PLF600)

● Mounting bracket (2 included)

BK-PLF

Rated flow rate
300: For PLF300
600: For PLF600



BK-PLF300: 9 g [0.32 oz]×2
BK-PLF600: 13 g [0.46 oz]×2

● Filter elements (with 2 O-rings)

E - **PLF**

Rated flow rate
300: For PLF300
600: For PLF600



E-300PLF: 35 g [1.23 oz]
E-600PLF: 63 g [2.22 oz]

Caution: The PLF050N and PLF100N have no additional parts.

Inner Construction and Parts Names and Major Materials

PLF050N

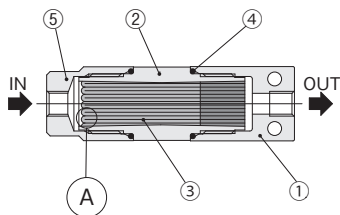

| No. | Name | Material |
|-----|------------------------------|--|
| ① | Main unit | Aluminum (electroless nickel plated) |
| ② | Plastic housing | PCT |
| ③ | Element | Fluorine type porous hollow fiber membrane |
| ④ | O-ring | Fluoro rubber (FKM) |
| ⑤ | Adapter (PLF050 only) | Aluminum (electroless nickel plated) |
| ⑥ | Retaining ring (PLF100 only) | SUS304 |

PLF100N

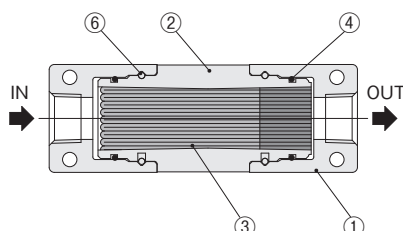

Ⓐ : Enlarged diagram of element

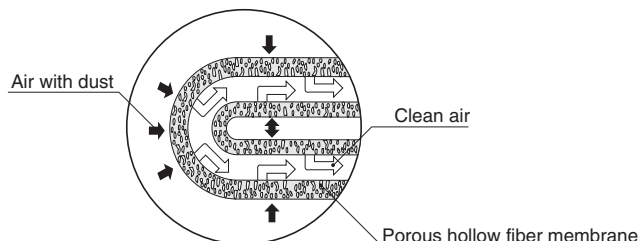

Caution: Do not disassemble the PLF050N or PLF100N.

PLF300

Female thread type

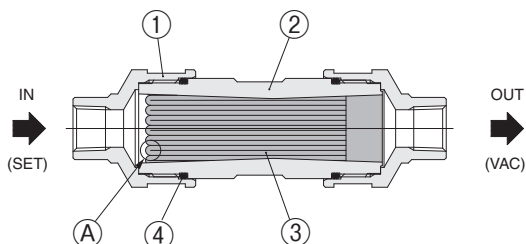

| No. | Name | Material |
|-----|---|--|
| ① | Female thread adapter (Fitting adapter) | Aluminum (anodized) |
| ② | Plastic housing | PCT |
| ③ | Element | Fluorine type porous hollow fiber membrane |
| ④ | O-ring | Fluoro rubber (FKM) |
| ⑤ | Release ring | Aluminum (anodized) |
| ⑥ | Guide ring | Brass (electroless nickel plated) |
| ⑦ | Elastic sleeve | FKM |

Ⓐ : Enlarged diagram of element

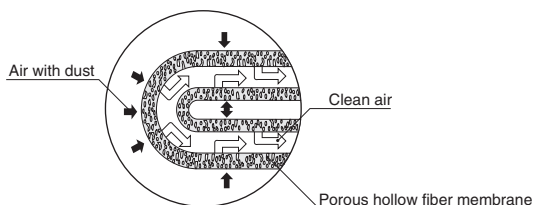

Quick fitting type

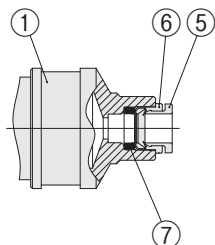

PLF600

Female thread type

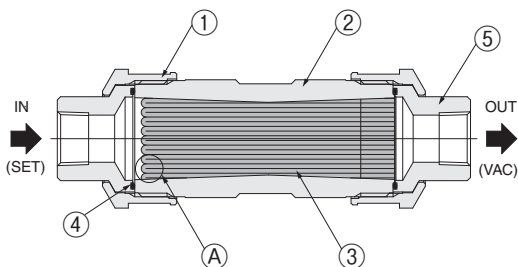

| No. | Name | Material |
|-----|-----------------|--|
| ① | Cover | Aluminum (anodized) |
| ② | Plastic housing | PCT |
| ③ | Element | Fluorine type porous hollow fiber membrane |
| ④ | O-ring | Fluoro rubber (FKM) |
| ⑤ | Adapter | Female thread specifications: Aluminum (anodized) Quick fitting specifications: PBT |
| ⑥ | Release ring | POM |
| ⑦ | Guide ring | Brass (electroless nickel plated) |
| ⑧ | Elastic sleeve | FKM |
| ⑨ | Lock claw | Stainless steel |

Ⓐ : Enlarged diagram of element

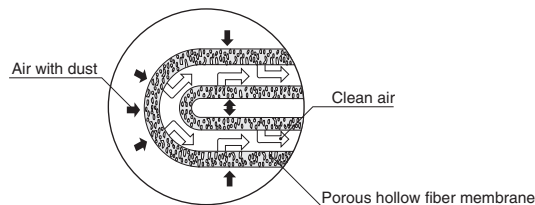

Quick fitting type

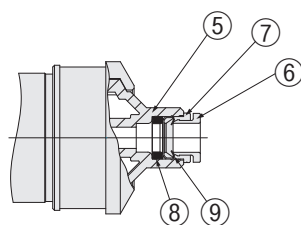

Flow rate characteristics

PLF050N

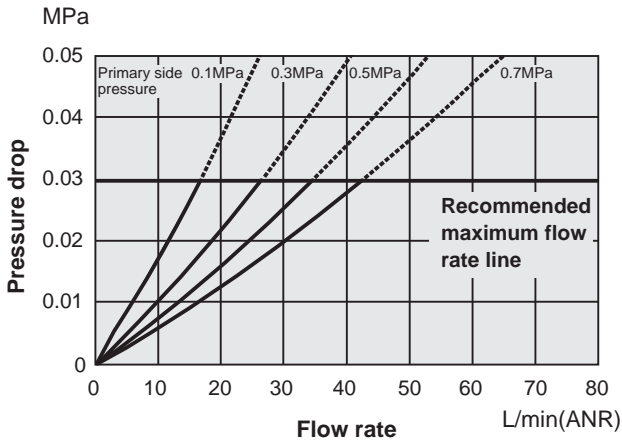

PLF100N

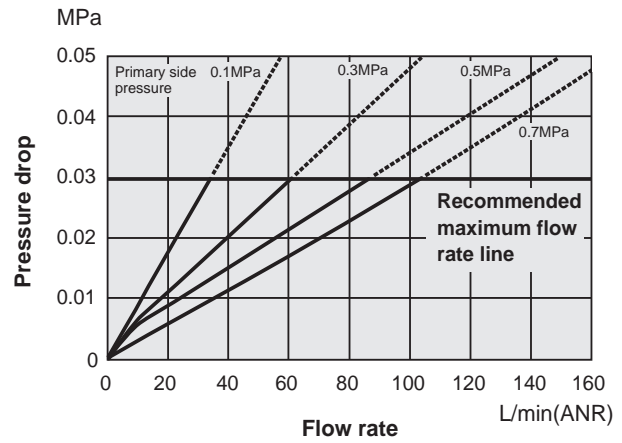

Caution: Normally use the product within the recommended maximum flow rate.

Female thread type

PLF300-02

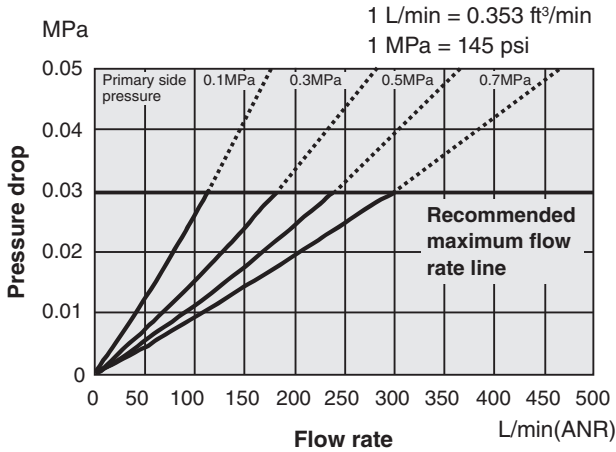

Quick fitting type

PLF300-J6

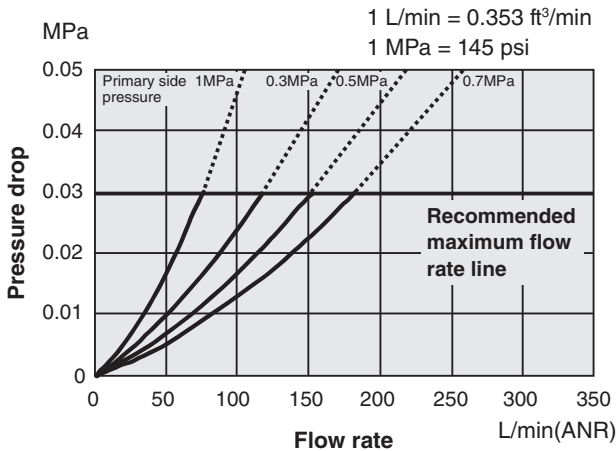

PLF300-J8

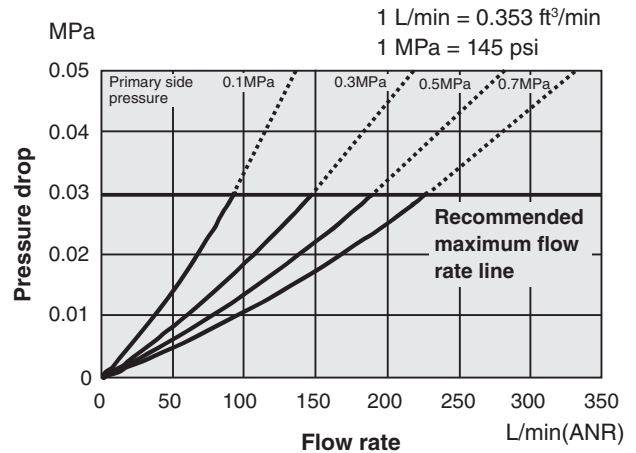

Caution: Normally use the product within the recommended maximum flow rate.

Flow rate characteristics

Female thread type

PLF600-02

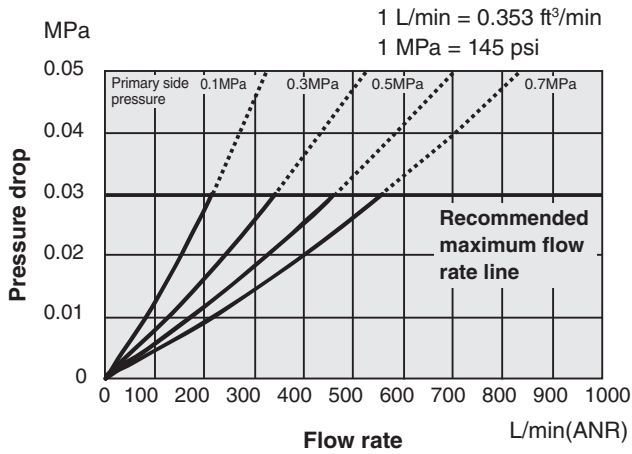

PLF600-03

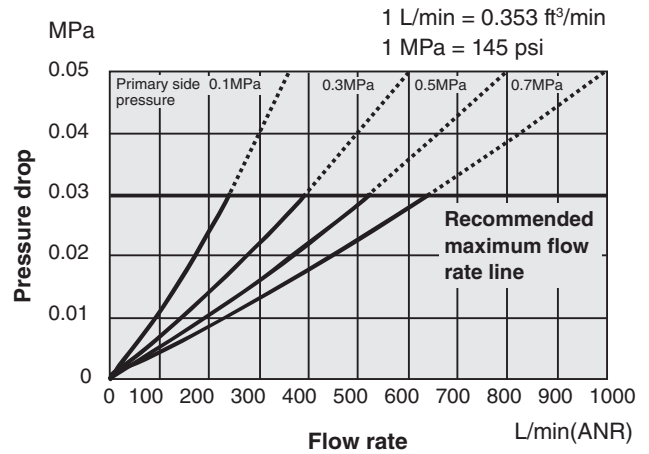

Quick fitting type

PLF600-J8

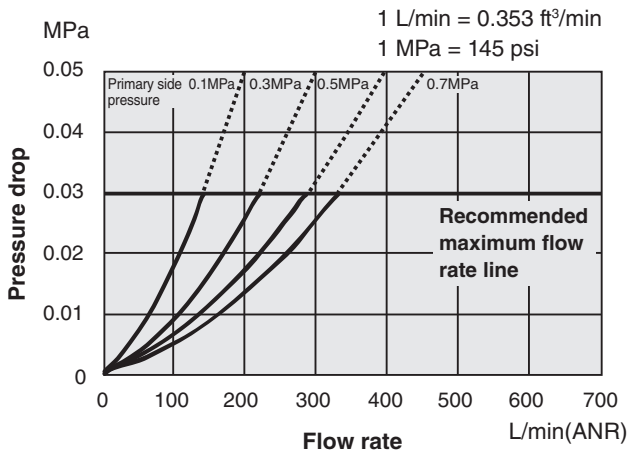

PLF600-J10

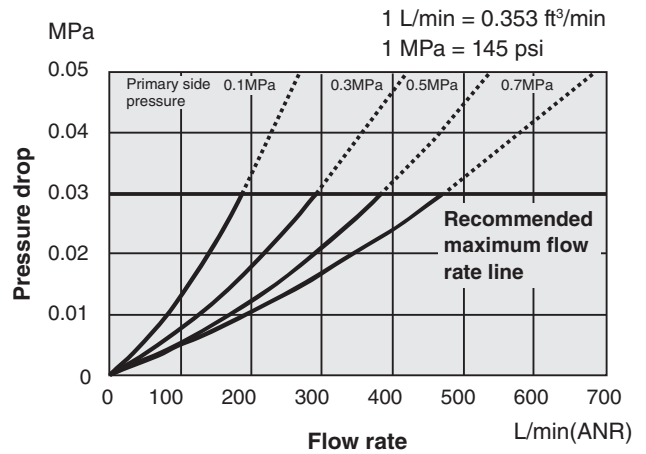

Caution: Normally use the product within the recommended maximum flow rate.

Dimensions (mm [in.])

PLF050N

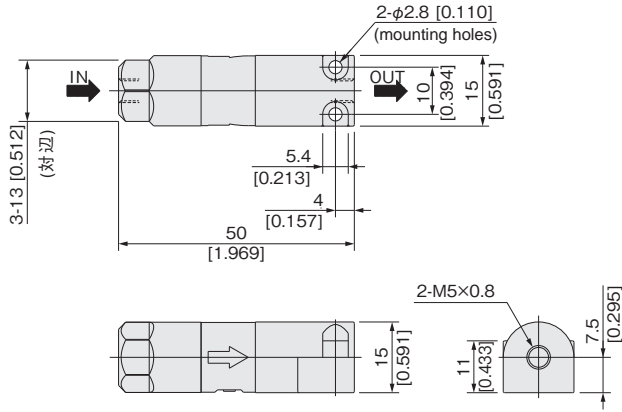

PLF100N

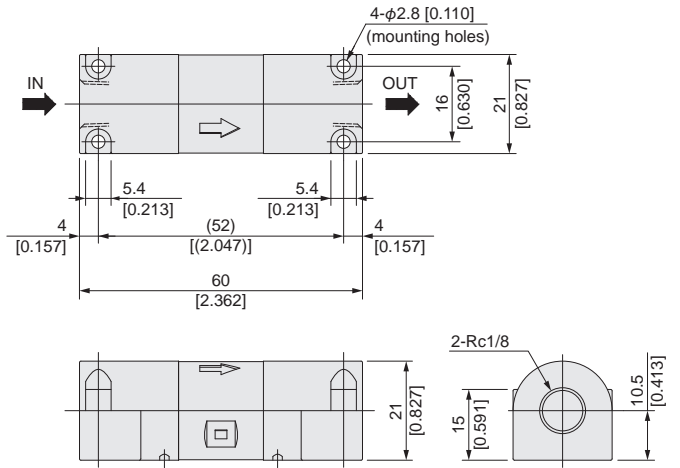

●Mounting is possible even by only 2 mounting holes on either IN or OUT side.

Female thread type

PLF300-02

For -B (2 pieces)

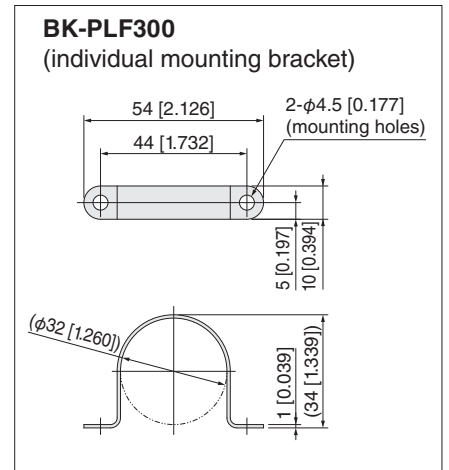
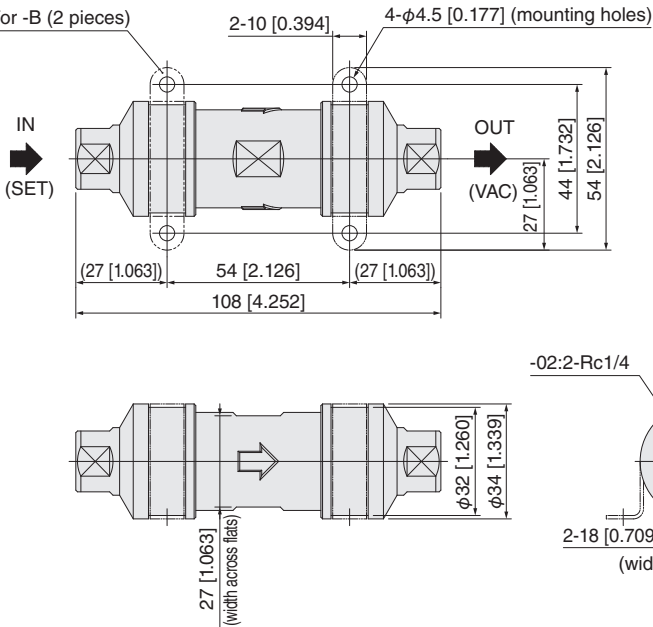

Quick fitting type

PLF300-J6/-J8

For -B (2 pieces)

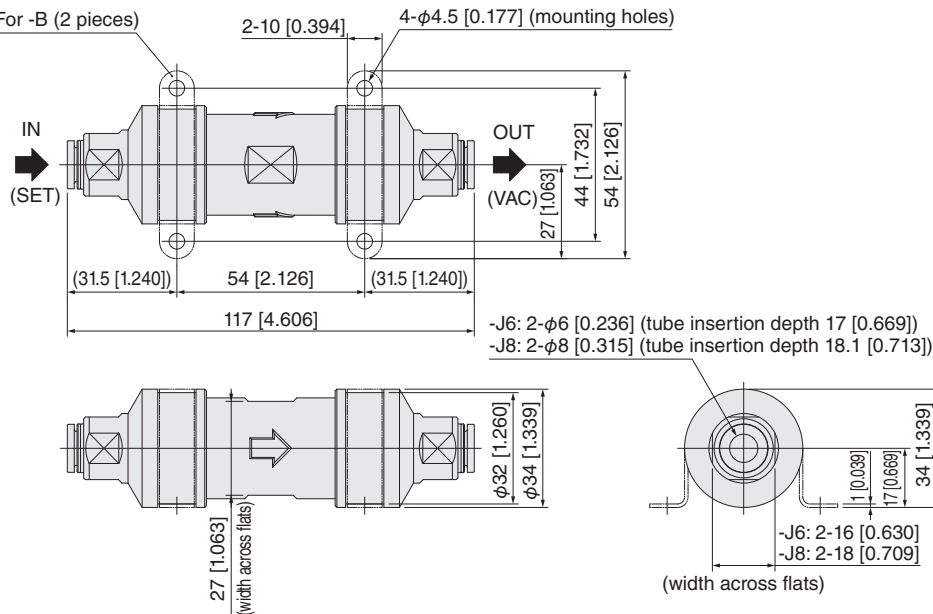

Dimensions (mm [in.])

Female thread type

PLF600-02/-03

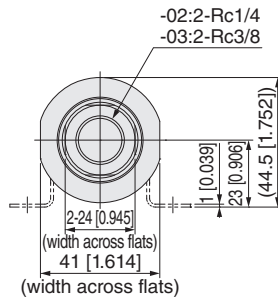
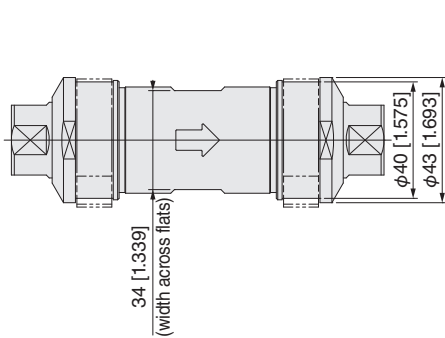
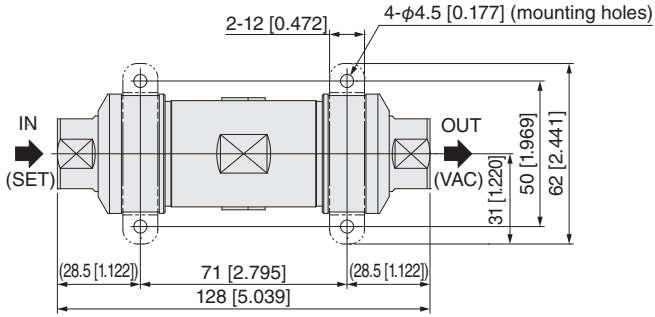

Quick fitting type

PLF600-J8/-J10

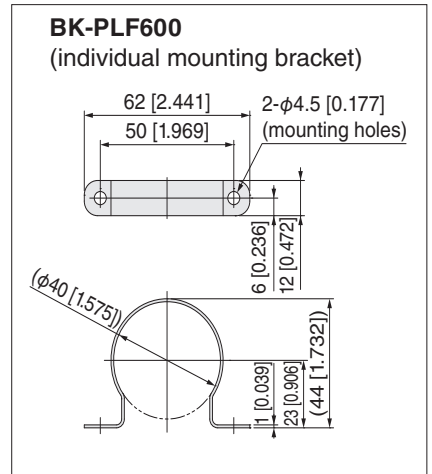
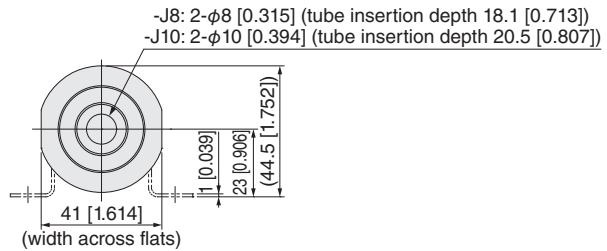
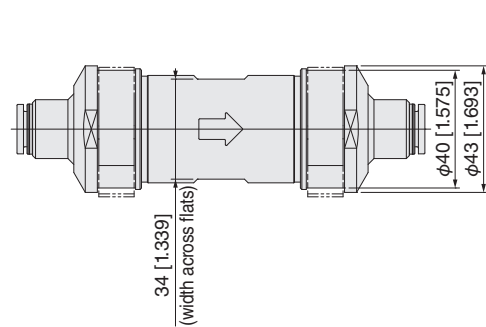
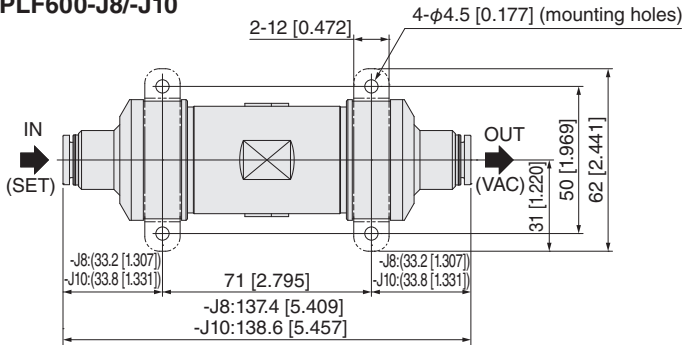

Handling Instructions and Precautions (PLF Series)



General precautions

Common to PLF050N, PLF100N, PLF300, and PLF600

1. Before doing piping work, thoroughly flush the inside of the pipes (blow out with compressed air). Machining chips, sealing tape, rust and other debris remaining from the piping work may cause reduced performance and functionality or stop functions.
2. Do not use any medium except air and N₂. Contact the nearest Koganei sales office or overseas department if you are considering using something other than these.
3. This product cannot be used if the medium or ambient atmosphere includes any of the substances below.
Organic solvents, phosphate type hydraulic oil, sulfur dioxide gas, chlorine gas, acids, or other corrosive gases.
4. Avoid installation and use in locations where the supplied air or ambient temperature exceeds the operating temperature range.
5. Cover the unit when using it in locations where it might be subject to excessive dust, dripping water, dripping oil, etc.
6. Do not allow excessive external forces to act on the product.
7. Avoid uses that exceed the maximum operating pressure.
8. Do not directly expose the product to ultraviolet light or wind and rain.
9. This is an industrial product. Do not use it in life-support equipment.
10. The objective of in-line filters is to remove solid matter, so remove any water and oil first.

● Recommended circuit (positive pressure)

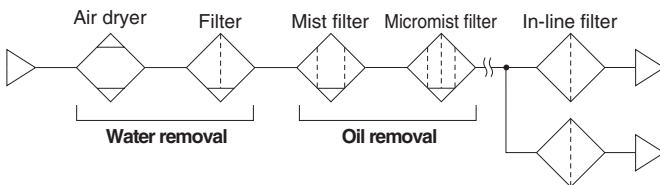

11. Performance and functions may decrease as the pneumatic equipment ages. Always conduct daily inspections of the pneumatic equipment, and confirm that all requisite system functions are satisfactory, to prevent accidents from happening.
12. See "Replacing Elements" to do the PLF300/PLF600 element replacement procedure correctly. As a guideline, replace elements if you notice a reduction in performance during operation, such as the element appears dirty or a lower vacuum is reached during operation.



Mounting and Piping

PLF050N and PLF100N

1. When working on piping, use the metal part with the piping thread as shown in the illustration below for spanner hanging. For PLF100N, the metal and plastic parts can be rotated in circumference direction, but it is not designed to withstand rotational usage for operation. Mount the product without rotating as much as possible. After mounting, make sure to use the product so it will not rotate during operation.

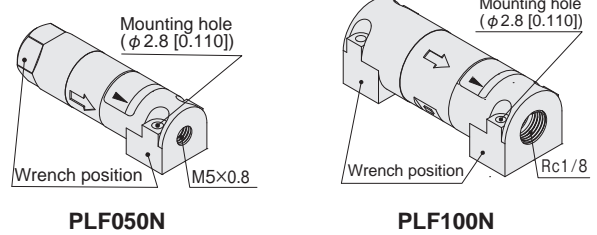

2. When connecting steel pipes, fittings, etc. to the threaded area of the IN and OUT sides, follow the recommended tightening torque specified by our company.

| Recommended tightening torque | | N·m [in·lbf] |
|-------------------------------|-------------------------------|----------------------------------|
| Connecting thread | M5 × 0.8 | R1/8 |
| Torque | 1 to 1.5 [8.851 to 13.277] | 4.5 to 6.5 [39.830 to 57.532] |

3. Pipe the product so that air will flow in the direction of the arrow (flow mark) on the product, or the black arrow on the product label. (Do not use in the opposite direction.)

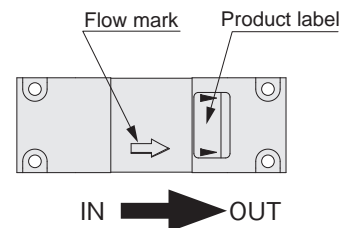

4. The mounting direction is free, but make sure not to apply strong impact or vibration to the main body.
5. Use the mounting holes and mount securely. For PLF100N, mounting is possible even by only 2 mounting holes on either IN or OUT side. However, be careful not to rotate.

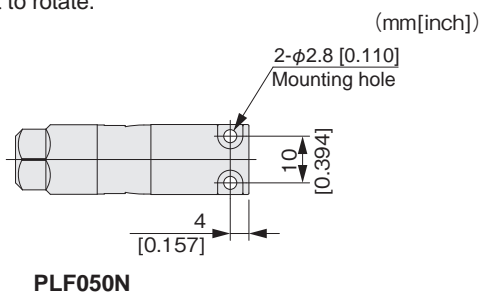

PLF050N

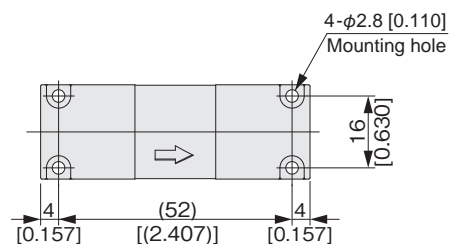

PLF100N

6. The inline filter uses plastic parts and cannot be installed with bending or torsional moments applied. Doing so may cause damage to the product.

Handling Instructions and Precautions (PLF Series)



General precautions

PLF300

■ Mounting and Piping

1. When doing piping work, place the wrench on the two flat places of the female thread adapter on the side to tighten.

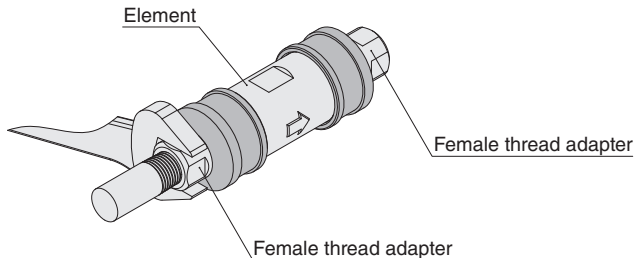

- Note** Using the two flat places on the element during piping work could damage them.

2. When installing steel piping or joints to the threaded pipe of the female thread adapter, tighten them to the Koganei recommended tightening torque.

- Note** Tightening with excess torque may damage the product or injure workers or operators.

| Recommended tightening torque | | N·m [in·lbf] |
|-------------------------------|---------------------------|--------------|
| Connecting thread | R1/4 | |
| Torque | 7 to 9 [61.957 to 79.659] | |

3. Do piping so the air flows in the direction of the arrow (flow mark) shown on the product. (Do not use the opposite direction.)

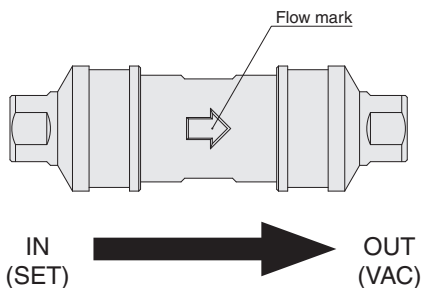

4. In-line filters have some resin parts, so they cannot be installed under conditions of bending moment or torsional moment. Doing so could damage the product.
5. Mounting orientation can be varied, but do not subject the main unit directly to strong impact or vibration.
6. Install the optional mounting brackets (2 pieces) on each side when installing the product.

Bracket installation procedure

- 1) Slot the mounting brackets into the mounting grooves (see image below) on the female thread adapter (fitting adapter).

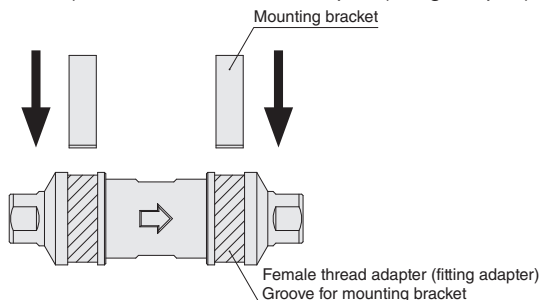

- 2) Tighten M4 screws into the 4 mounting holes of the mounting brackets to install them securely. Refer to the dimension diagrams on [page 11](#) for the installation dimensions of mounting brackets.

7. Assure there is sufficient space for maintenance inspections and replacing elements.

- Note** If you do not ensure enough space to remove the mounting bracket and female thread adapter (fitting adapter), you cannot replace the element.

8. Connecting/disconnecting tubes

Precautions for attaching tubes

- 1) Confirm that the cut surface of the tube is cut straight across, that the outer surface of the tube is not damaged, and that the tube has not become oval shaped.
- 2) When connecting tubes, if you do not insert the tube all the way to the tube end, it may result in leaks.

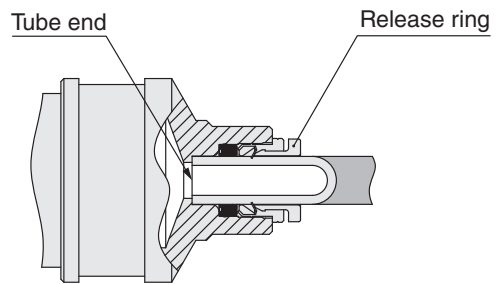

- 3) After installing the tube, pull on it to check that it does not come off.

Precautions for removing tubes

- 1) Before removing tubing, be sure to confirm that the pressure inside the tubing is zero (atmospheric pressure).
- 2) Uniformly press the release ring inwards as far as it goes and then pull out the tubing. If you do not fully press in the release ring, the tube may not come out, or the tubing may become scratched causing debris to be left inside the fitting.

■ Recommended usable tubes

Use of Koganei urethane tubes is recommended. Use tubing with outside diameter precision within ± 0.15 mm [0.006 in] (nominal) and with ovality (difference between major axis and minor axis) within 0.2 mm [0.008 in].

- Note**
1. Use tubing with an exterior that is not damaged. If tubing becomes damaged after repeated use, cut off the damaged portion.
 2. Do not allow tubing to become severely bent or twisted near the connection to a fitting. Such a condition creates the risk of air leakage. The table below shows minimum bending radius for urethane tubing.
 3. Do not use extremely soft tubing, which causes a severe drop in pull-out strength.

| Tube size | Minimum bending radius |
|------------------|------------------------|
| $\phi 6$ [0.236] | 15 [0.591] |
| $\phi 8$ [0.315] | 20 [0.787] |

Handling Instructions and Precautions (PLF Series)

■ Element replacement

Replace the PLF300 according to the following procedure.

1. Operation error

- Stop operation and confirm that the pressure inside the tubing is zero (atmospheric pressure).
- To install a bracket, remove the installation bracket from the in-line filter.

2. Removing elements

- Rotate the female thread adapter (fitting adapter) counterclockwise to remove it from the filter. If the female thread adapter (fitting adapter) is difficult to remove, use a wrench or something across the two flat places on the female thread adapter (fitting adapter) to rotate it. When doing this, be careful not to damage the element.
- Remove the opposite side in the same way.
- Use an air blower to remove any dust that has accumulated on the female thread adapter (fitting adapter).

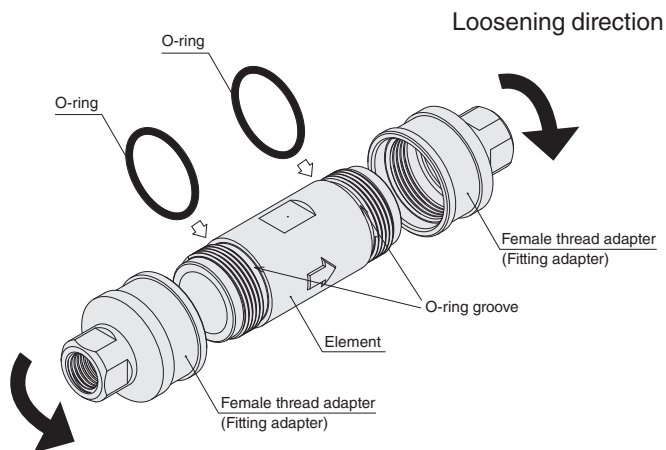

3. Installing elements

- Assemble the replacement O-rings into the grooves of the O-rings on the element.
- Install the female thread adapter (fitting adapter) to the filter. To tighten the female thread adapter (fitting adapter), tighten it by hand without using a tool. There is a possibility of causing damage to the plastic parts if you use a tool and over tighten them, so do not use excessive force when tightening.
(Tightening torque guidelines: 1.5 to 2 N·m [13.277 to 17.702 in·lbf])
- Be careful that you do not touch the internal hollow fiber membrane that is inside the element. Doing so could reduce performance or damage the hollow fiber membrane.
- Do the same procedure for the opposite side.

Handling Instructions and Precautions (PLF Series)

PLF600

■ Mounting and Piping

- When doing piping work, place the wrench on the two flat places of the female thread adapter on the side to tighten.

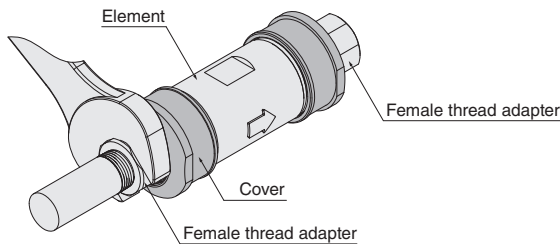

Note Using the two flat places on the cover or element during piping work could damage them.

- When installing steel piping or joints to the threaded pipe of the female thread adapter, tighten them to the Koganei recommended tightening torque.

Note Tightening with excess torque may damage the product or injure workers or operators.

Recommended tightening torque N·m [in·lbf]

| | | PLF600 | |
|-------------------|------------------------------|----------------------------------|--|
| Connecting thread | R1/4 | R3/8 | |
| Torque | 7 to 9 [61.957 to 79.659] | 12.5 to 14.5 [110.6 to 128.3] | |

- Do piping so the air flows in the direction of the arrow (flow mark) shown on the product. (Do not use the opposite direction.)

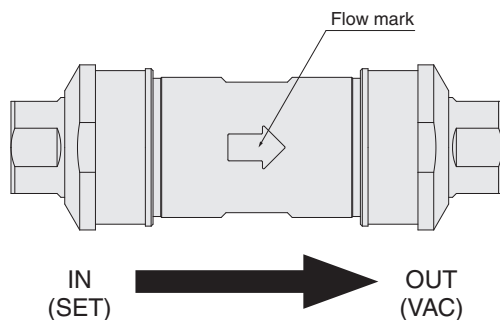

- In-line filters have some resin parts, so they cannot be installed under conditions of bending moment or torsional moment. Doing so could damage the product.
- Mounting orientation is can be varied, but do not subject the main unit directly to strong impact or vibration.
- Install the optional mounting brackets (2 pieces) on each side when installing the product.

Bracket installation procedure

- Slot the mounting brackets into the mounting grooves (see image below) on the cover.

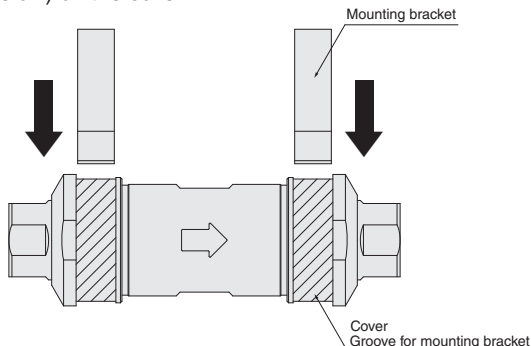

- Tighten M4 screws into the 4 mounting holes of the mounting brackets to install them securely. Refer to the dimension diagrams on [page 12](#) for the installation dimensions of mounting brackets.

- Assure there is sufficient space for maintenance inspections and replacing elements.



If you do not ensure enough space to remove the mounting bracket and cover, you cannot replace the element.

8. Connecting/disconnecting tubes

Precautions for attaching tubes

- Confirm that the cut surface of the tube is cut straight across, that the outer surface of the tube is not damaged, and that the tube has not become oval shaped.
- When connecting tubes, if you do not insert the tube all the way to the tube end, it may result in leaks.

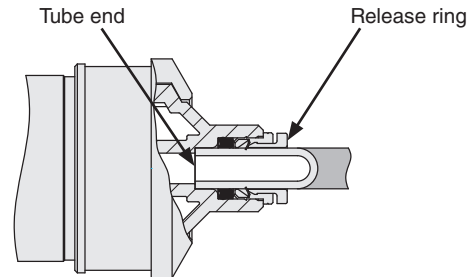

- After installing the tube, pull on it to check that it does not come off.

Precautions for removing tubes

- Before removing tubing, be sure to confirm that the pressure inside the tubing is zero (atmospheric pressure).
- Uniformly press the release ring inwards as far as it goes and then pull out the tubing. If you do not fully press in the release ring, the tube may not come out, or the tubing may become scratched causing debris to be left inside the fitting.

■ Recommended usable tubes

Use of Koganei urethane tubes is recommended. Use tubing with outside diameter precision within ± 0.15 mm [0.006 in] (nominal) and with ovality (difference between major axis and minor axis) within 0.2 mm [0.008 in].



- Use tubing with an exterior that is not damaged. If tubing becomes damaged after repeated use, cut off the damaged portion.
- Do not allow tubing to become severely bent or twisted near the connection to a fitting. Such a condition creates the risk of air leakage. The table below shows minimum bending radius for urethane tubing.
- Do not use extremely soft tubing, which causes a severe drop in pull-out strength.

| Tube size | Minimum bending radius |
|-------------------|------------------------|
| $\phi 8$ [0.315] | 20 [0.787] |
| $\phi 10$ [0.394] | 27 [1.063] |

Handling Instructions and Precautions (PLF Series)

■ Element replacement

Replace the PLF600 according to the following procedure.

1. Operation error

- Stop operation and confirm that the pressure inside the tubing is zero (atmospheric pressure).
- To install a bracket, remove the installation bracket from the in-line filter.

2. Removing elements

- Rotate the cover counterclockwise to remove it from the element. If the cover is difficult to remove, use a wrench or something across the two flat places on the element to rotate it. When doing this, be careful not to damage the element. Remove the opposite side in the same way.
- Remove the O-ring from the female thread adapter (fitting adapter).
- Use an air blower to remove any dust that has accumulated on the female thread adapter (fitting adapter) or cover.

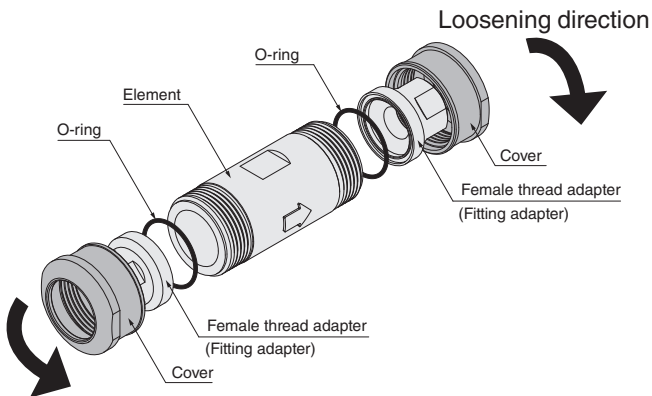

3. Installing elements

- Assemble the replacement O-rings into the grooves on the female thread adapter (fitting adapter).
- Pass the female thread adapter (fitting adapter) through the cover and install the cover to the element. To tighten the cover, tighten it by hand without using a tool. There is a possibility of causing damage to the plastic parts if you use a tool and over tighten them, so do not use excessive force when tightening. (Tightening torque guidelines: 1.5 to 2 N·m [13.277 to 17.702 in-lbf])
- Be careful that you do not touch the internal hollow fiber membrane that is inside the element. Doing so could reduce performance or damage the hollow fiber membrane.
- Do the same procedure for the opposite side.

Clean Line Filters

CLF Series

Symbols

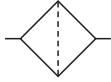

Specifications

| Item | Model | CLF050-01 | CLF050-02 |
|---|------------------------------------|---|-----------|
| Medium | | Air, N ₂ , Ar, He, O ₂ , CO ₂ | |
| Connection port diameter | Rc | 1/8 | 1/4 |
| Operating temperature range | °C [°F] | 80 [176] (MAX.) | |
| Particle filtering efficiency | % | 100% (0.01μm) | |
| Filtration rating | μm | 0.01 | |
| Filtration area | cm ² [in ²] | 10 [1.550] or more | |
| Maximum operating pressure | MPa [psi] | 1.0 [145] | |
| Proof pressure | MPa [psi] | 1.5 [218] | |
| Element differential pressure | MPa [psi] | 0.5 [73] | |
| Element reverse tolerance differential pressure | MPa [psi] | 0.07 [10] | |
| Element structure | | Dual-layer structure with PTFE membrane and PTFE non-woven fabric | |
| Weight | g [oz] | 135 [4.76] | |
| Production method | | Entirely produced in class10000 clean room | |



Order Codes

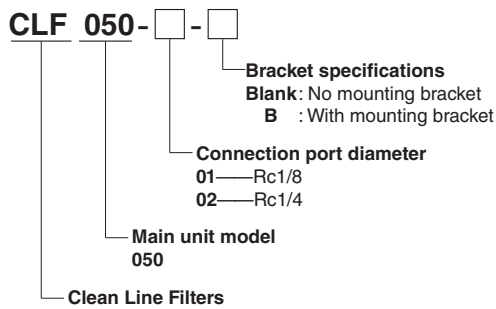

Additional Parts (sold separately)

Replacement elements (with O-ring)



Mounting bracket



Inner Construction and Parts Names and Materials of Major Parts

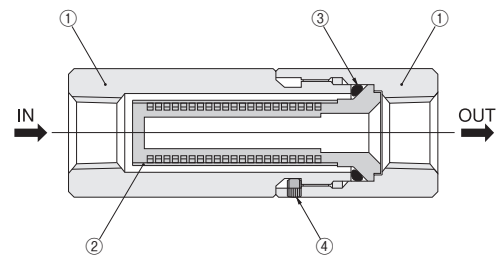

| No. | Name | Material |
|-----|--------------------------------------|--|
| ① | Main unit (housing) | SUS316 (outer and inner surfaces electro polished) |
| ② | Element (membrane, non-woven fabric) | Housing: PFA, element: PTFE |
| ③ | O-ring (seal) | FPM |
| ④ | Lock screw (M3×0.5) | SUS304 |
| - | Mounting bracket | SUS304 |

Caution: Normally use the product within the recommended maximum flow rate.

Flow rate characteristics

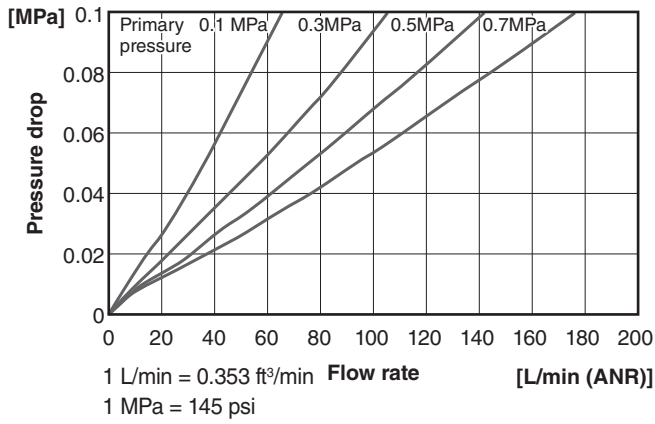

Dimensions (mm [in.])

CLF050-□

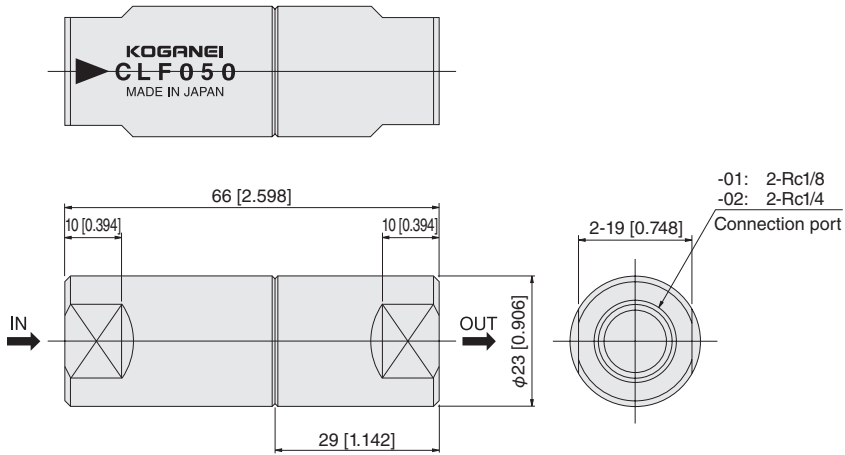

Options

-B: Mounting bracket

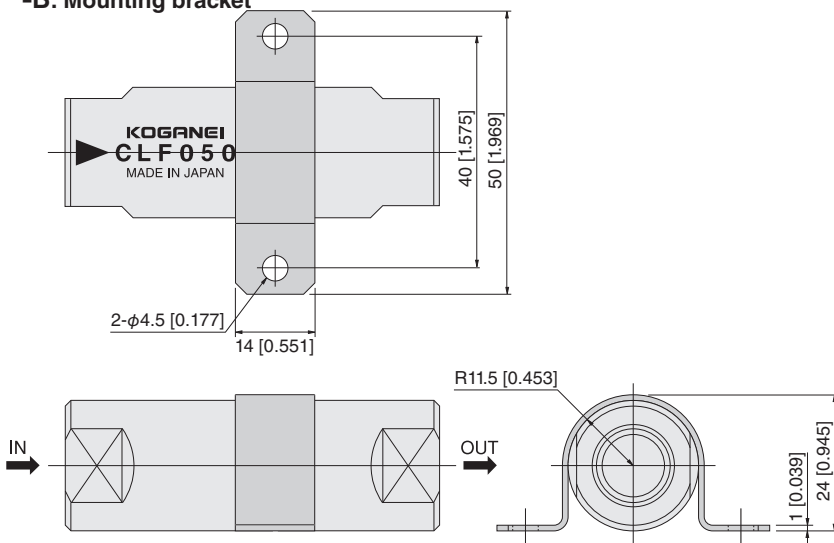

Handling Instructions and Precautions (CLF Series)



Mounting and Piping

Opening the packaging

The filters and replacement elements are clean packed in double packaging in a clean room, so when you open the package, we recommend opening it in a clean room or in a clean environment.

Installation

Piping work is done by placing a wrench across the flat parts of a main unit that has piping threads, and preventing the main unit from rotating.

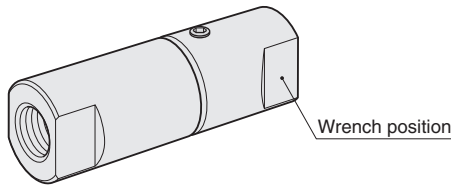

Do piping so the air flows in the direction of the arrow shown on the main unit. (Refer to the diagram below)

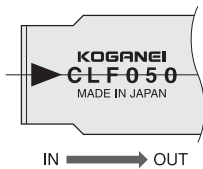

Use the optional mounting brackets when installing the product.

Flushing

The products are cleaned with clean air before shipping, however, micro-particles could be generated by the effect of vibrations during transportation.

Before initial use and when replacing elements, flush (blow out with clean air) the inside of the pipes.

Element replacement

To replace an element, remove the main unit from the pipe fittings. The elements come with an O-ring, so replace them and the O-ring together.

When replacing elements, do not touch the element or the inside of the main unit with your bare hands. We recommend wearing dust-proof gloves while replacing elements.

The main units have a break-down system that is tightened using screws, and a lock screw is tightened to secure them, so before loosening the screws on the main unit, first loosen the lock screw. Also, after installing the main unit, be sure to tighten the lock screw.

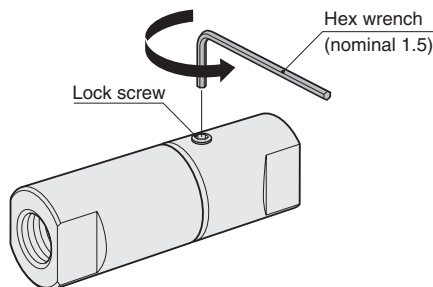

Tightening torque for threaded parts of main unit:

3.92 N·m [34.696 in·lbf]

Tightening torque for threaded parts of lock screws:

0.39 N·m [3.452 in·lbf]

Medium

General-purpose gases are the intended medium for the product. (General purpose gases are noted in the specifications.)

Note that other gases cannot be used.

● Usable medium

Of general purpose gases, gases used as carrier gases in particular, can be used.

Nitrogen (N₂), argon (Ar), helium(He), Oxygen(O₂), carbon dioxide (CO₂)

● Unusable medium

Note that the specialized gases, which are used in processing lines, that are listed below cannot be used.

CVD and epitaxial gases

Mono-silane (SiH₄), dichlorosilane (SiH₂Cl₂), phosphine (PH₃), diborane (B₂H₆), ammonia (NH₃), tungsten hexafluoride (WF₆), hydrogen chloride (HCl)

Gases for ion implantation

Arsine (AsH₃), boron trifluoride (BF₃)

Etching gases

Boron trichloride (BCl₃), carbon tetrafluoride (CF₄), Nitrogen trifluoride (NF₃)



General precautions

1. Use a medium that is within the specified range of mediums. Do not use any other medium.
2. Avoid use installation and use in locations where the ambient temperature exceeds the maximum operating temperature.
3. Avoid uses that exceed the maximum operating pressure.
4. Do not allow excessive external forces to act on the product.
5. Do not directly expose the product to ultraviolet light or wind and rain.

In-line filter for positive and negative pressure

VLF Series

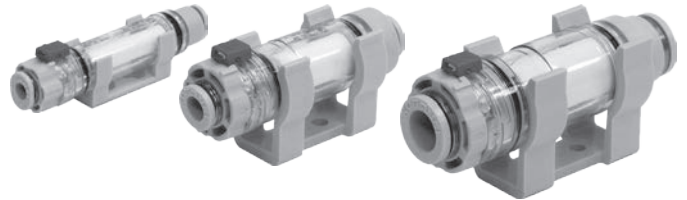

Symbols

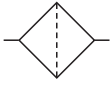

Specifications

| Item | Basic type | VLF010 | | VLF020 | | VLF050 | | |
|---|------------------------------------|--|------------|---------------|------------|---------------|------------|------------|
| | | SUS303-VLF010 | | SUS303-VLF020 | | SUS303-VLF050 | | |
| Pipe fittings | mm [in.] | 4 [0.157] | 6 [0.236] | 4 [0.157] | 6 [0.236] | 6 [0.236] | 8 [0.315] | 10 [0.394] |
| Medium | | Air | | | | | | |
| Maximum operating pressure | MPa [psi] | 1.0 [145] (at 20°C [68°F]) ^{Note 1} | | | | | | |
| Pressure used for vacuum | kPa [inHg] | -100 [-29.540] | | | | | | |
| Withstand pressure | MPa [psi] | 1.5 [218] | | | | | | |
| Operating temperature range | °C [°F] | 0 to 50 [32 to 122] (non-freezing) | | | | | | |
| Filtration rating ^{Note 2} μm | | 5 | | | | | | |
| Particle filtering efficiency % | | 95 | | | | | | |
| Filtration area | cm ² [in ²] | 4.7 [0.729] | | 7.5 [1.163] | | 12.7 [1.969] | | |
| Recommended flow rate ^{Note 3} L/min (ANR) [ft ³ /min (SCFM)] | | 10 [0.353] | | 15 [0.530] | 20 [0.706] | 25 [0.883] | 50 [1.766] | 60 [2.119] |
| Weight | g [oz] | 9 [0.32] | 8.5 [0.30] | 21 [0.74] | 22 [0.78] | 35 [1.23] | 35 [1.23] | 39 [1.38] |

Note 1: Maximum operating pressure value is when the temperature is 20 °C [68 °F]. To use the product in other temperature ranges, see "Diagram on relation of operating temperature and maximum operating pressure" on [page 20](#).

2: According to Koganei stipulated conditions.

3: This flow rate is during vacuum generation. (pressure loss of 3 kPa [0.886 inHg] or less)

When using positive pressure, see "Flow rate characteristics" on [page 20](#).

Note: When using the product in a high-temperature environment, such as due to heat compression, refer to the diagram on relation of operating temperature and maximum operating pressure to assure that the environment's temperature and the product's temperature for your application do not exceed the operating temperature.

Order Codes

● In-line filter for positive and negative pressure (release ring color: light grey)

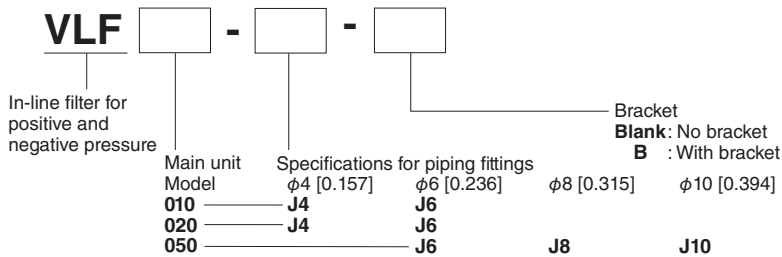

● SUS303 specifications In-line filter for positive and negative pressure (release ring color: dark grey)

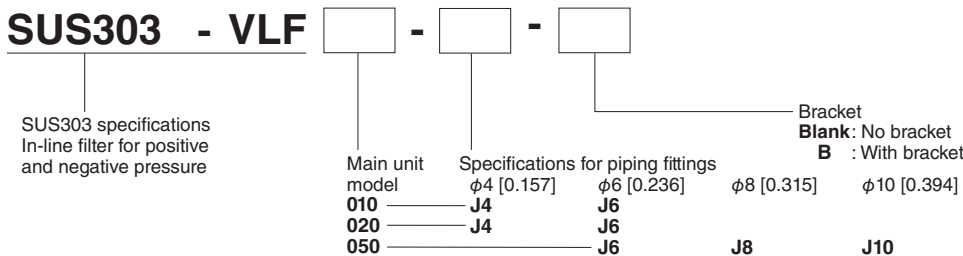

■ Additional parts

● Bracket (1 pc./bag)

BK - VLF []

Main unit model
010: 10 L/min (ANR) [0.353 ft³/min (SCFM)]
020: 20 L/min (ANR) [0.706 ft³/min (SCFM)]
050: 50 L/min (ANR) [1.766 ft³/min (SCFM)]

● Replacement elements (10 pc./bag)

E - [] VLF

Main unit model
010: 10 L/min (ANR) [0.353 ft³/min (SCFM)]
020: 20 L/min (ANR) [0.706 ft³/min (SCFM)]
050: 50 L/min (ANR) [1.766 ft³/min (SCFM)]

Inner construction

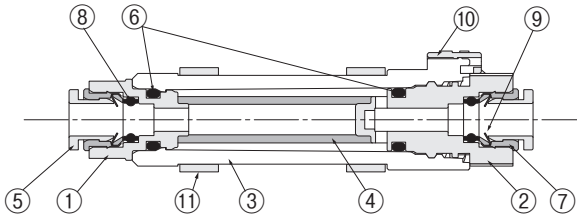

Major parts and materials

| No. | Model Name | Material | |
|-----|----------------|----------------------------------|-------------------------|
| | | VLF□ | SUS303-VLF□ |
| ① | Main fitting A | PBT | |
| ② | Main fitting B | PBT | |
| ③ | Cover | PCTG | |
| ④ | Element | PVF | |
| ⑤ | Release ring | POM (light grey) | POM (dark blue) |
| ⑥ | O-ring | NBR | HNBR |
| ⑦ | Guide ring | Brass, electroless nickel plated | Special stainless steel |
| ⑧ | Elastic sleeve | NBR | HNBR |
| ⑨ | Lock claw | Stainless steel | |
| ⑩ | Slide lock | POM | |
| ⑪ | Bracket | POM | |

Note: SUS303 equivalent (austenitic or ferritic)

Diagram on relation of operating temperature and maximum operating pressure

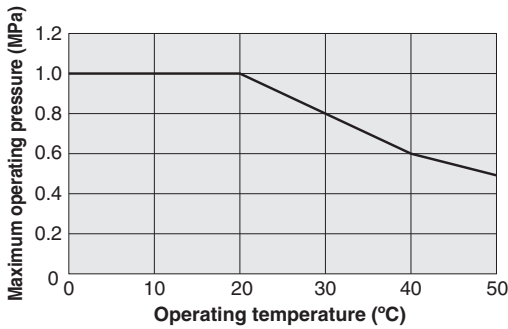

Flow rate characteristics

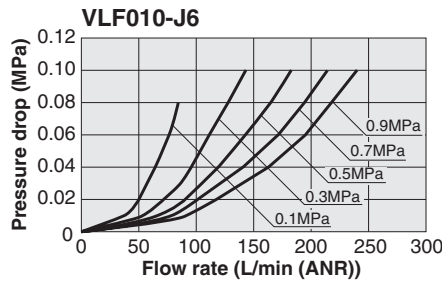
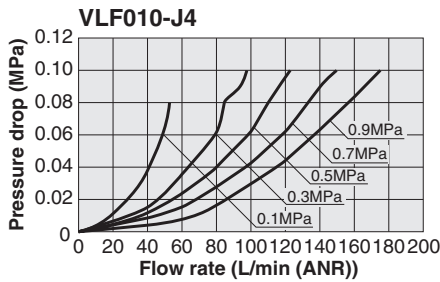

1 L/min = 0.353 ft³/min
1 MPa = 145 psi

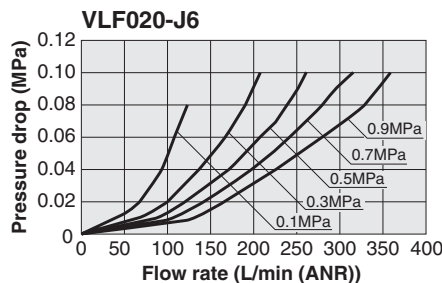
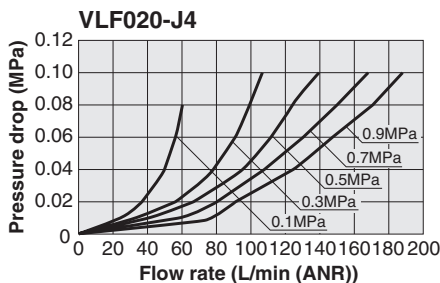

1 L/min = 0.353 ft³/min
1 MPa = 145 psi

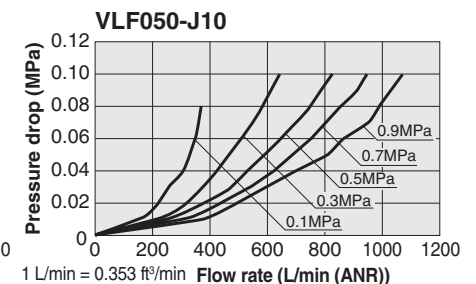
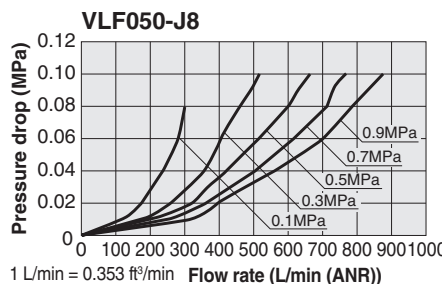
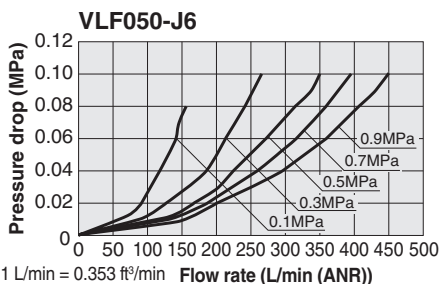

1 L/min = 0.353 ft³/min
1 MPa = 145 psi

1 L/min = 0.353 ft³/min
1 MPa = 145 psi

1 L/min = 0.353 ft³/min
1 MPa = 145 psi

Dimensions (mm [in.])

VLF010-□-□
SUS303-VLF010-□-□

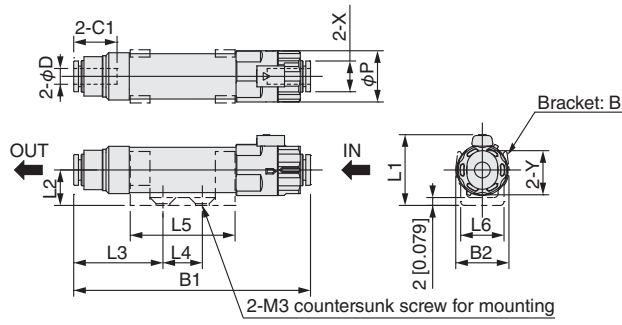

VLF020-□-□
SUS303-VLF020-□-□

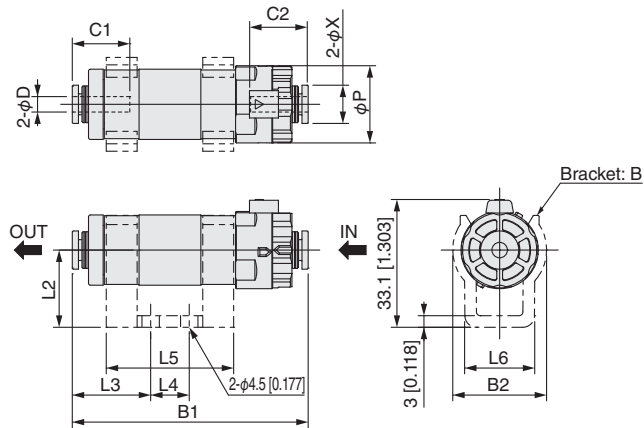

VLF050-□-□
SUS303-VLF050-□-□

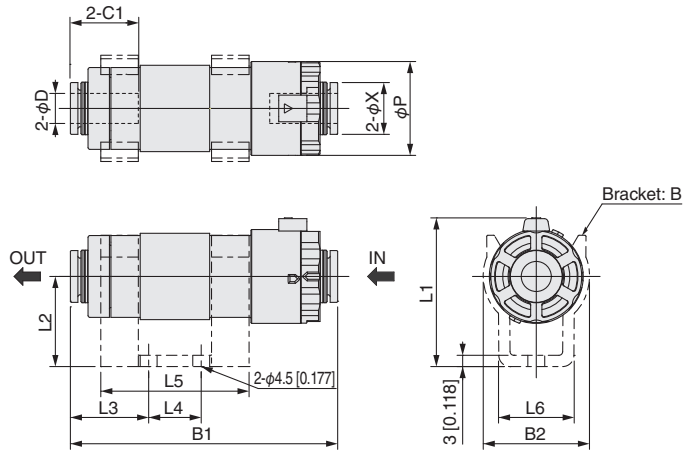

| Model | Tube outer diameter φD | C1 | C2 | B1 | B2 | L1 | L2 | L3 | L4 | L5 | L6 | φP | X | Y |
|--------------|------------------------|--------------|--------------|--------------|--------------|--------------|------------|--------------|------------|--------------|--------------|------------|--------------|--------------|
| VLF010-J4-□ | 4 [0.157] | 11 [0.433] | - | 60.1 [2.366] | 13.5 [0.531] | 18 [0.709] | 9 [0.354] | 22.7 [0.894] | 10 [0.394] | 26.6 [1.047] | 11 [0.433] | 13 [0.512] | 7.8 [0.307] | 9.8 [0.386] |
| VLF010-J6-□ | 6 [0.236] | 11.6 [0.457] | - | 64.4 [2.535] | 13.5 [0.531] | 18 [0.709] | 9 [0.354] | 25.1 [0.988] | 10 [0.394] | 26.6 [1.047] | 11 [0.433] | 13 [0.512] | 9.8 [0.386] | 11.8 [0.465] |
| VLF020-J4-□ | 4 [0.157] | 14.9 [0.587] | 14.9 [0.587] | 61.1 [2.406] | 24.3 [0.957] | 33.1 [1.303] | 20 [0.787] | 20.3 [0.799] | 10 [0.394] | 33 [1.299] | 18.2 [0.717] | 20 [0.787] | 9.9 [0.390] | - |
| VLF020-J6-□ | 6 [0.236] | 16 [0.630] | 17 [0.669] | 65.5 [2.579] | 24.3 [0.957] | 33.1 [1.303] | 20 [0.787] | 24.2 [0.953] | 10 [0.394] | 33 [1.299] | 18.2 [0.717] | 20 [0.787] | 11.8 [0.465] | - |
| VLF050-J6-□ | 6 [0.236] | 17 [0.669] | - | 71.9 [2.831] | 28.3 [1.114] | 39.6 [1.559] | 24 [0.945] | 19.6 [0.772] | 14 [0.551] | 39.5 [1.555] | 20.2 [0.795] | 25 [0.984] | 11.8 [0.465] | - |
| VLF050-J8-□ | 8 [0.315] | 18.1 [0.713] | - | 71.1 [2.799] | 28.3 [1.114] | 39.6 [1.559] | 24 [0.945] | 20.9 [0.823] | 14 [0.551] | 39.5 [1.555] | 20.2 [0.795] | 25 [0.984] | 13.8 [0.543] | - |
| VLF050-J10-□ | 10 [0.394] | 19.2 [0.756] | - | 77.3 [3.043] | 28.3 [1.114] | 39.6 [1.559] | 24 [0.945] | 26.8 [1.055] | 14 [0.551] | 39.5 [1.555] | 20.2 [0.795] | 25 [0.984] | 16.8 [0.661] | - |

Handling Instructions and Precautions (VLF Series)

WARNING

1. Periodically do maintenance inspections of filter elements. Clogged elements could cause reduced performance or trouble. Before replacing elements, take safety precautions, make the pressure inside the filter atmospheric pressure, and fully understand the "Element replacement procedure".
2. Do not subject the product to pulling, twisting, or bending loads, and do not drop it or subject it to extreme impacts. There is a risk of damage or breakage.
3. The cover material is PCTG, so avoid use in areas where the product is in contact with or exposed to chemical (see below) environments, which could damage the product.

| Names of chemicals | |
|----------------------|--|
| Thinner | Cyclohexane |
| Carbon tetrachloride | Trichloroethylene |
| Chloroform | Sulphuric acid |
| Acetic ester | Lactic acid |
| Aniline | Water soluble cutting oil (alkaline oil) |

* Contact your nearest Koganei sales office for other chemicals, which are not mentioned above, that cannot be used.

4. Always lock the slide lock before using the product. Also, while the slide lock is locked, if the fittings are rotated or excessive force is applied to the slide lock, there is a risk of the slide lock malfunctioning and the fitting and cover separating and being damaged.
5. The product's maximum operating pressure varies depending on the operating temperature range (temperature in operating environment. To use the product, be sure to refer to the "Diagram on relation of operating temperature and maximum operating pressure" on page 2, and use the product within that range.
6. Do not use the product in direct sunlight, near mercury vapor lamps, or near equipment that generates ozone. Deterioration of rubber parts caused by ozone may reduce performance and functions, stop functions, rapidly reduce performance, or reduce operating life.

CAUTION

1. Before connecting pipes, confirm the direction of air flow by the arrow on the cover. The filter cannot perform fully if connected backwards.
2. Note that, when using the product in a circuit that alternates application of vacuum and vacuum breaker, the dust removed by the element could be exhausted in the breaker air.
3. When disassembling and assembling the product for maintenance, confirm whether the O-rings have been damaged. Using a damaged O-ring could cause problems, such as leaks, to occur.
4. After removing dust and replacing the element, securely fasten main fitting B and confirm there are no leaks.



General precautions

Precautions for attaching tubes

- ① Confirm that the cut surface of the tube is cut straight across, that the outer surface of the tube is not damaged, and that the tube has not become oval shaped.
- ② When connecting tubes, if you do not insert the tube all the way to the tube end, it may result in leaks.



Tube end

- ③ After installing the tube, pull on it to check that it does not come off.
- ④ Do not meaninglessly press on the release ring before attaching a tube. Doing so may cause the tube to become detached.

Precautions for removing tubes

- ① Before removing tubing, be sure to confirm that the pressure inside the tubing is zero.
- ② Uniformly press the release ring inwards as far as it goes and then pull out the tubing. If you do not fully press in the release ring, the tube may not come out, or the tubing may become scratched causing debris to be left inside the fitting.

How to attach and detach tubes

1. Attaching tubes

Push the tube all the way to the end so the lock claws hold it in place, and the elastic sleeve seals around the outside of the tube.

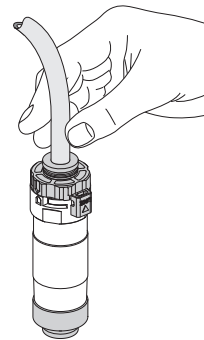

2. Removing tubes

When removing a tube, pressing the release ring opens the lock claws and the tube can be pulled out. Be sure to stop the air before removing tubes.

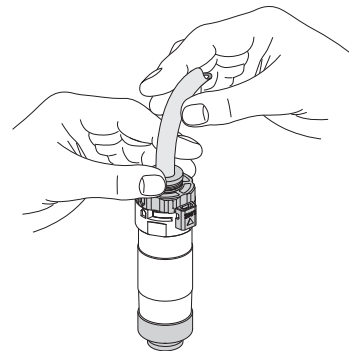

Securing the bracket

Use the mounting holes on the bracket to securely fasten the bracket with the following screws. (Refer to the diagram for the external dimensions of the body regarding the pitch of the holes for mounting.)

Mounting screws **VLF010**: M3 countersunk screw, **VLF020, 050**: M4 screws

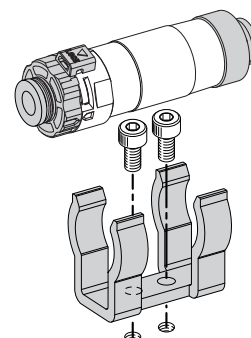

Handling Instructions and Precautions (VLF Series)

Element replacement procedure

- ① Make the internal pressure of the in-line filter the same as atmospheric pressure.
- ② Release the red slide lock. (Opposite direction of the LOCK arrow.)
- ③ Rotate the main fitting B 180° counterclockwise.
- ④ Remove the rotated main fitting B from the cover, and then replace the element.
- ⑤ Use compressed air or something, to remove any dust from inside the cover if necessary.
- ⑥ Attach the element to the element holder on the cover and insert it into main fitting B, and then rotate main fitting B clockwise until it stops.
- ⑦ When you close them up, confirm that the lock position arrow on the cover aligns with the lock position arrow on main fitting B, and then raise (direction of the LOCK arrow) the slide lock and confirm it is securely locked.

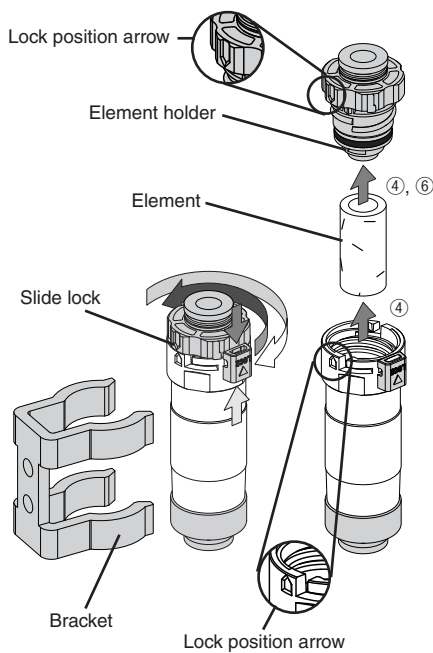

Usable tubes

Use of both nylon tubing and urethane tubing is supported. Tubing outside diameter precision should be within ± 0.1 mm [0.004 in] (nominal) for nylon tubing and within ± 0.15 mm [0.006 in] (nominal) for urethane tubing. Use tubing with ovality (difference between major axis and minor axis) within 0.2 mm [0.008 in]. (We recommend using Koganei tubes.) Use of tubing that is not a Koganei genuine product or a compatible (recommended) product may result in tube disconnection, air leakage, or other problems. Be sure to check on tubing before building a pneumatic system.



1. Use tubing with an exterior that is not damaged. If tubing becomes damaged after repeated use, cut off the damaged portion.
2. Do not allow tubing to become severely bent or twisted near the connection to a fitting. Such a condition creates the risk of air leakage. The table below shows minimum bending radius for nylon and urethane tubing.
3. Do not use extremely soft tubing, which causes a severe drop in pull-out strength.
4. Before removing any tubes, always turn off the air supply. Also, be sure to confirm that the air inside the pipes is completely vented before starting.

| Tube size | Minimum bending radius | |
|-------------------|------------------------|---------------|
| | Nylon tube | Urethane tube |
| $\phi 4$ [0.157] | 20 [0.787] | 10 [0.394] |
| $\phi 6$ [0.236] | 30 [1.181] | 15 [0.591] |
| $\phi 8$ [0.315] | 50 [1.969] | 20 [0.787] |
| $\phi 10$ [0.394] | 80 [3.150] | 27 [1.063] |

Socket filter for vacuum

VSF Series



Symbols

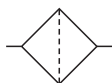

Specifications

| Item | Basic type | Basic type | | |
|---|---|--|-------------|-------------|
| | | VSF-J3 | VSF-J4 | VSF-J6 |
| Medium | | Air | | |
| Operating pressure range | kPa [inHg] | -100 to 0 [-29.540 to 0] ^{Note 1} | | |
| Operating temperature range | °C [°F] | 0 to 60 [32 to 140] (non-freezing) | | |
| Filtration rating ^{Note 2} | μm | 5 | | |
| Particle filtering efficiency | % | 95 | | |
| Filtration area | cm ² [in ²] | 0.8 [0.124] | | 1.1 [0.171] |
| Recommended flow rate ^{Note 3} | L/min (ANR) [ft ³ /min (SCFM)] | 5 [0.177] | 7.5 [0.265] | 11 [0.389] |
| Weight | g [oz] | 1.4 [0.049] | 1.5 [0.053] | 2.5 [0.088] |

Note 1: When used for vacuum breaking applications, the proof pressure is maximum 0.2 MPa [29 psi].

2: According to Koganei stipulated conditions.

3: This flow rate is during vacuum generation. (pressure loss of 3 kPa [0.886 inHg] or less)

Remarks: The internal elements cannot be replaced. Replace the filters with new socket filters for vacuum.

Order Codes

● Socket filter for vacuum

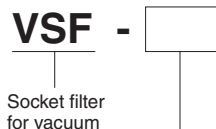

Applicable fitting/tube diameter

J3: φ3 mm [0.118 in.] (socket side φ3 mm [0.118 in.])

J4: φ4 mm [0.157 in.] (socket side φ4 mm [0.157 in.])

J6: φ6 mm [0.236 in.] (socket side φ6 mm [0.236 in.])

Flow rate characteristics

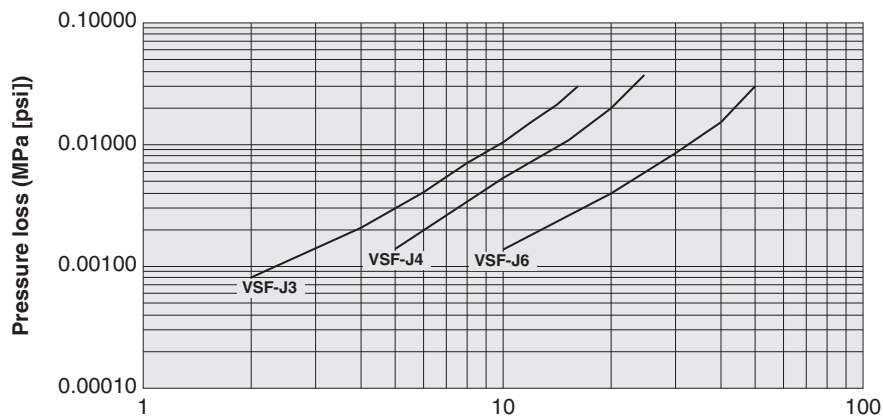

Flow rate (L/min (ANR)) 1 L/min = 0.353 ft³/min
1 MPa = 145 psi

Inner construction

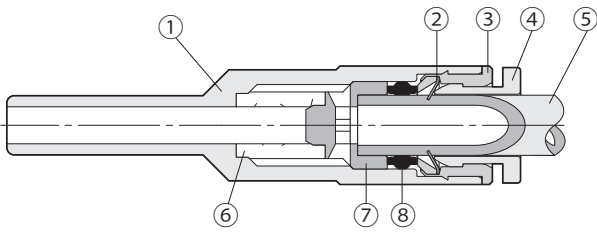

Major parts and materials

| No. | Name | Model | VSF□ |
|-----|----------------|-------|----------------------------------|
| ① | Main unit | | PP |
| ② | Lock claw | | Stainless steel |
| ③ | Guide ring | | Brass, electroless nickel plated |
| ④ | Release ring | | POM |
| ⑤ | Tube | | Urethane or nylon |
| ⑥ | Element | | PVF |
| ⑦ | Element brace | | POM |
| ⑧ | Elastic sleeve | | NBR |

Dimensions (mm [in.])

VSF-J3

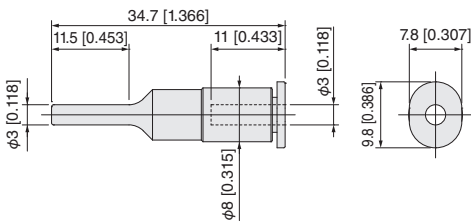

VSF-J4

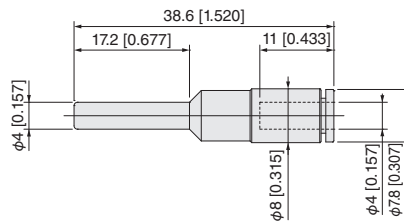

VSF-J6

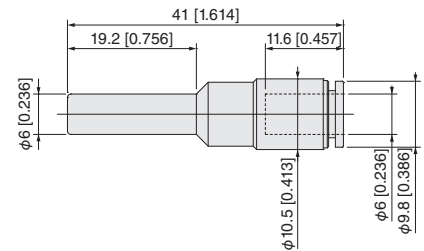

Handling Precautions

⚠ WARNING

- The VSF are vacuum filters. Avoid use in locations subject to continuous pressurized conditions. They are not built to be explosion-proof, so there is a risk of injury to people if the main unit is damaged.
- Do periodic inspections. Clogged elements cause reduced performance or trouble. Individual elements cannot be replaced, so replace the vacuum filter with a new one when doing replacements.
- The material for the filter body is PP, so the plastic may deteriorate in direct sunlight or ultraviolet radiation. If using the product where it is in contact with or exposed to chemical environments, first confirm whether there is any effect on the material. Or, contact your nearest Koganei sales office.
- Do not use the product in direct sunlight, near mercury vapor lamps, or near equipment that generates ozone. Deterioration of rubber parts caused by ozone may reduce performance and functions, stop functions, rapidly reduce performance, or reduce operating life.

⚠ CAUTION

- Piping connections are: Socket side to the vacuum generator side port; and the fitting side to the workpiece side port. The product can be used with the connections reversed, but the filter area is reduced. Also, the element cannot be checked for clogs.
- Note that, when using the product in a circuit that alternates application of vacuum and vacuum breaker, the dust removed by the element could be exhausted in the breaker air.
- When attaching tubes, do not apply excessive force. There is a risk of damaging the filter.

Handling Instructions and Precautions (VSF Series)

Piping direction

Connect the pipes so the air flows from the fitting side to the socket side. (Refer to the diagram below)

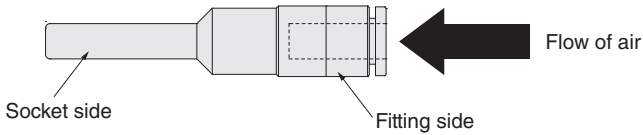

Precautions for attaching tubes

- ① Confirm that the cut surface of the tube is cut straight across, that the outer surface of the tube is not damaged, and that the tube has not become oval shaped.
- ② When connecting tubes, if you do not insert the tube all the way to the tube end, it may result in leaks.

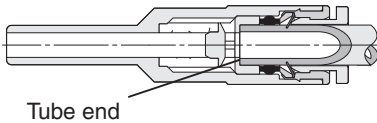

- ③ After installing the tube, pull on it to check that it does not come off.
- ④ Do not meaninglessly press on the release ring before attaching a tube. Doing so may cause the tube to become detached.

Precautions for removing tubes

- ① Before removing tubing, be sure to confirm that the pressure inside the tubing is zero.
- ② Uniformly press the release ring inwards as far as it goes and then pull out the tubing. If you do not fully press in the release ring, the tube may not come out, or the tubing may become scratched causing debris to be left inside the fitting.

Usable tubes

Use of both nylon tubing and urethane tubing is supported. Tubing outside diameter precision should be within ± 0.1 mm [0.004 in] (nominal) for nylon tubing and within ± 0.15 mm [0.006 in] (nominal) for urethane tubing. Use tubing with ovality (difference between major axis and minor axis) within 0.2 mm [0.008 in]. (We recommend using Koganei tubes.) Use of tubing that is not a Koganei genuine product or a compatible (recommended) product may result in tube disconnection, air leakage, or other problems. Be sure to check on tubing before building a pneumatic system.



1. Use tubing with an exterior that is not damaged. If tubing becomes damaged after repeated use, cut off the damaged portion.
2. Do not allow tubing to become severely bent or twisted near the connection to a fitting. Such a condition creates the risk of air leakage. The table below shows minimum bending radius for nylon and urethane tubing.
3. Do not use extremely soft tubing, which causes a severe drop in pull-out strength.
4. Before removing any tubes, always turn off the air supply. Also, be sure to confirm that the air inside the pipes is completely vented before starting.

mm [in.]

| Tube size | Minimum bending radius | |
|------------|------------------------|---------------|
| | Nylon tube | Urethane tube |
| φ3 [0.118] | — | 7 [0.276] |
| φ4 [0.157] | 20 [0.787] | 10 [0.394] |
| φ6 [0.236] | 30 [1.181] | 15 [0.591] |

Memo

A series of horizontal dotted lines for writing.

Memo

A series of horizontal dotted lines for writing.

Limited Warranty

KOGANEI CORP. warrants its products to be free from defects in material and workmanship subject to the following provisions.

Warranty Period The warranty period is 180 days from the date of delivery.

Koganei Responsibility If a defect in material or workmanship is found during the warranty period, KOGANEI CORP. will replace any part proved defective under normal use free of charge and will provide the service necessary to replace such a part.

Limitations

- This warranty is in lieu of all other warranties, expressed or implied, and is limited to the original cost of the product and shall not include any transportation fee, the cost of installation or any liability for direct, indirect or consequential damage or delay resulting from the defects.

- KOGANEI CORP. shall in no way be liable or responsible for injuries or damage to persons or property arising out of the use or operation of the manufacturer's product.

- This warranty shall be void if the engineered safety devices are removed, made inoperative or not periodically checked for proper functioning.

- Any operation beyond the rated capacity, any improper use or application, or any improper installation of the product, or any substitution upon it with parts not furnished or approved by KOGANEI CORP., shall void this warranty.

- This warranty covers only such items supplied by KOGANEI CORP. The products of other manufacturers are covered only by such warranties made by those original manufacturers, even though such items may have been included as the components.

The specifications are subject to change without notice.

URL: <http://www.koganeiusa.com>

E-mail: sales@koganeiusa.com



KOGANEI CORPORATION

OVERSEAS DEPARTMENT

3-11-28, Midori-cho, Koganei City, Tokyo 184-8533, Japan
Tel: 81-42-383-7271 Fax: 81-42-383-7276

KOGANEI INTERNATIONAL AMERICA, INC.

48860 Milmont Drive, Suite 108C, Fremont, California 94538
Tel: 1-510-744-1626 Fax: 1-510-744-1676

SHANGHAI KOGANEI INTERNATIONAL TRADING CORPORATION

Room 2606-2607, Tongda Venture Building No.1, Lane 600, Tianshan Road,
Shanghai, 200051, China
Tel: 86-21-6145-7313 Fax: 86-21-6145-7323

TAIWAN KOGANEI TRADING CO., LTD.

Rm. 2, 13F., No88, Sec. 2, Zhongxiao E. Rd., Zhongzheng Dist., Taipei City 100,
Taiwan (ROC)
Tel: 886-2-2393-2717 Fax: 886-2-2393-2719

KOGANEI KOREA CO., LTD.

6F-601, Tower Bldg., 1005, Yeongdeong-dong, Giheung-gu, Yongin-si, Gyeonggi-do,
446-908, Korea
Tel: 82-31-246-0414 Fax: 82-31-246-0415

KOGANEI (THAILAND) CO., LTD.

555 Rasa Tower 1, 12th Floor, Unit 1202 and 1207, Phaholyothin Road, Chatuchak, Bangkok
10900 Thailand
Tel: 66-2-937-4250 Fax: 66-2-937-4254

KOGANEI AUTOMATION (MALAYSIA) SDN.BHD.

Suite 29-2, Level 29, Menara 1MK, No.1, Jalan Kiara, Mont Kiara
50480, Kuala Lumpur, Malaysia
Tel: 60-12-537-7086

KOGANEI ASIA PTE. LTD.

69 Ubi Road 1, #05-18 Oxley Bizhub, Singapore 408731
Tel: 65-6293-4512 Fax: 65-6293-4513